



## Energy efficiency and system optimization by replacing of water cooled condenser with air cooler in zagros petrochemical complex.\*

Mohammad GHOLIPOUR

*Graduate Student, Process Engineering, Faculty of Engineering - Chemical, Ahar Branch, Islamic Azad University, Ahar ,I.R.Iran*

Received: 01.02.2015; Accepted: 05.05.2015

**Abstract.** In this paper, the feasibility of replacing the water cooled condenser instead air cooler of using disposable technologies once through and cooling tower water is salty and sweet of economic operations is examined. In hot and humid areas of our country like assluyeh, wide temperature changes during the day especially in warm seasons of year affect the atmospheric distillation tower conditions for purification of products both in quantity and quality. This changeable temperature conditions cause the waste of produced methanol from the bottom of tower and cooling operation in air cooler wouldn't be well done. Since air is as coolant in air cooler and due to low heat capacity of air (1.0035j/g k) to water (4.1813j/g k), this types of exchangers have lower heat efficiency. Because there's access to water sources of Persian Gulf, the feasibility of substituting water exchanger by using once through technology, the salt water or desalt water cooling tower was studied based on practical and economic issues. Based on these studies, it is suggested to apply water exchanger which use cooling tower technology of sweet water accompanied by sweet water maker (MED) set instead of air cooler in Zagros petrochemical complex. Because this project not only has higher practical efficiency considering to air cooler but also can save a lot of electricity and the expenditure of maintenance of equipment will be decreased.

**Keywords:** Air cooler, Cooling Towers, Technologies once through, estimated investment cost.

### 1. INTRODUCTION

Today, cooling towers and their peripheral equipment's have become an integral part of many industrial projects. However, there's a need for carrying out certain chemical or physical processes, and also in some sections of manufacturing units. Prior to sending the finished products to storage systems, or because of some process requirements, the need for recooling is inevitable. Some common and well-known methodologies currently being used in relation to cooling systems in refineries and petrochemical companies are as follows:

1. Dry cooling systems
2. Once - through cooling systems
3. Cooling systems along with cooling Tower.

The type of technology being used for cooling the main product of a Methanol unit at Zagross Petrochemical Co. is dry cooling system (air- cooled).

\*This article is extracted from the Master's Thesis.

\* Corresponding author. *Email address: gholipour.mo@gmail.com*

## **2. STATEMENT OF THE PROBLEM**

In hot and humid regions of Iran, live Assaluyeh, wide temperature variations during the day, particularly in hot seasons, Can impact temperature –dependent operation of an air cooler. This is because the rate of cooling in such an exchanger is significantly dependent on curtain environmental factor such as wind, and temperature of the medium. Also, during hot seasons, the rate of power in air coolers is seriously decreased. A phenomenon known as "recurring air rotation" is another factor that may un-predictably reduce operational efficiency of air coolers. If such a cooler is placed in the lower direction of wind near high buildings, then the hot air emitted from the cooler is carried away by the wind. Some of this hot air, however, after colliding with a barrier, is diverted and returns back to the system. When cooling operations in an air cooler is not done properly, it can cause a rise in the pressure exerted on Atmospheric distillation tower, there by producing an increase in the percentage of Methanol at the end – part of distillation tower.

## **3. SIGNIFICANCE OF THE PROBLEM**

Using a unique configuration in designing air coolers in all types of geographical regions having different climates is by no means logical. Therefore, a careful investigation of resources before selecting a type of cooling system, and also an emphasis on precise execution of the process involved are essential. However, operational costs related to the changes at early stages of design process will certainly be far less than the case where it is required to design and implement such a system for an existing project. Therefore, in such cases, a great amount of repeated work as well as additional costs may be introduced in the project.

Emphasis on the fact that there's as such as 6700 Kilo-meters of coastal stripe in Iran, the task of replacing a water exchanger equipped with a once –through cooling system or a cooling tower system (self-water , fresh water) for an air – cooled system, requires some investigation on operational and economical aspects of the issue. Such an investigation can be explained by the following facts:

1. The rate of cooling operation for a water exchanger in hot and humid regions (such as Assaluyeh) is better compared with an air-cooled system.
2. Controlling the stable conditions related to temperature is easier in a water –cooled exchanger compared to an air-cooled system.
3. Costs of operation, repair, and maintenance for a water exchanger is less compared to an air- cooled system.

## **4. RESEARCH OBJECTIVES (GENERAL AND ESPECIAL)**

Considering the problems associated with using air- cooled systems for cooling Methanol produced at distillation unit Zagross petrochemical Company, making use of water as a fluid coolant is suggested in order to overcome the problem. In this study, an examination of the energy efficiency as well as the issue of system optimization through, substitution of a water-cooled exchanger in place of an air-cooled system have been carried out on the bases of operational data and utilization experience obtained at Zagross petrochemical Co. The aim of this study has been to reduce the costs of investment, repair and maintenance, to control the operational conditions involved and to protect the environment.

## 5. REVIEW THE LITERATURE

Investigating the possibility of substituting a water –cooled exchanger in place yon air –cooled system, and making use of the technologies involved in once –through cooling systems and cooling tower systems in hot and humid areas with wide water resources is done for the first time in Iran. Selecting a superior cooling system may be done by considering the environmental requirements and the costs of investment involved. Therefore, by enforcing the Law of clean water, the U.S. Environmental Protection Agency (EPA), has required that all new and old power plants must utilize the best existing technologies in order to minimize any undesired environmental effects.

Attempts made by the Iranian Environment Protection Department since 1972, did ultimately result in operationalization of changing the technologies used in Once- through cooling systems in 1995. Also, in Dec. 2001, regulations for using water for cooling purposes in all new installations were issued; and it was announced that cooling tower systems are considered as containing the best existing technology of the time. However, the energy efficiency corresponding to such systems can yield a %98 reduction in environmental damages due to the structures there of.

**Table 1.** Some companies that use sea water for cooling towers are used in cooling systems.

Requesting company	Petrochemical Zagross	Al-Navassy	Dravu	Flor Daniel	Paolo Verdu 2
Project site	Assaluyeh petrochemical Zagroos	Oil Kuwait	Jabil petrochemical Saudi Arabia	Jabil petrochemical Saudi Arabia	Arizona
Water folw rate	47366	10203	35989	50180	587857
Hot water temp.(F)	123	103	121	125	119
Cold water temp.(F)	101	95	98	98	87
Humid air temp.(F)	91	88	92	92	77
Difference in lower domain	22	8	23	27	32
Nearing temp difference	6	7	6	6	10
Tower type	Cell –humid	Cell –humid	Cell –humid	Cell –humid	Ntural sucking uni direction flow
Year manufactured	2006	1983	1983	1983	1986

### Modelling and Process Designing

#### Phase one of project Designing

It includes mass and energy balance, process selection, preparing procedural currents board, and selecting features of process designing for equipment's.

#### 5.1. Mass and Energy Balance

The rate of compensational water is the sum of water west due to evaporation ( $W_{evap}$ ), Purification ( $W_{bd}$ ), and droplets running ( $W_d$ ) out of the system, which should be replaced. In Mathematical terms, we have:

$$W_{mu} = W_{evap} + W_{bd} + W_d \quad (1)$$

#### 5.2. Mass and Energy Balance for fresh water cooling tower

Energy efficiency and system optimization by replacing of water cooled condenser with air cooler in zagros petrochemical complex.\*

Considering the present efficiency measures for ordinary cooling fewer systems used in different industries, for each mega-watt of temperature load in heat exchanger systems (Condensers), approximately 84 cubic meter of water- p – low per hour is needed, provided that the amount of temperature rise in a water- coolant in a heat exchanger is 10 °C . Such an amount of flowing water will need about 1.8 cubic meter of water per hour as the compensational water. The rate of droplet running is less than %0.002 of the flowing water, and by considering special arrangements, it can be less than 0.005%.

**5.2.1. Mass and Energy Balance for salt –water cooling Tower**

A flow rate of approximately 200-500 gallons per minute for the running salt- water may be considered for each mega- watt temperature load in the condenser. Evaporated water flow for each mega- watt of temperature load is 10 gallons per minute. The purification rate for controlling the sediments, corrosion, etc. is adjusted by limiting the increase in water impurities during flowing. It amounts to 2.5 gallons per minute for each mega- watt of temperature load in the condenser. In general, the rate of compensational water per minute for each mega-watt of temperature load in the condenser is 12.5 gallons per minute.

**5.2.2. Project Design (Phase II)**

This phase includes an estimation of investment costs associated with substitution of a cooling tower in place of an air-cooled system. Estimating fixed investment costs, operational costs, and calculations related to capital return are all done in this phase.

**Table 2.** Estimation of fixed investment costs.

Direct costs= Materials and work force involved in actual installation in the factory (65-85 percent of fixed investment)	A. equipment +installation exact instruments + piping + Electric + insulation + painting (50-60 percent fixed investment)	Equipment purchased( 15-40 percent fixed investment)
		Installedwithinsulationandpainting(25-55 of equipment purchase price)
		exact instruments and control, installed (8% - 50% of equipment purchase price)
		Piping, installed(10%-80% of equipment purchase price)
		Electric, installed(10-40% of equipment purchase price)
Indirect costs = costs that do not relate directly to materials cost and cost of work force involved in installation in the factory (35-15 percent fixed investment)	B. building , processes, peripheral services (10-70 percent of equipment purchase price)	
	C. welfare services and spice creation (40-100% of equipment purchase price)	
	D. Land (1%-2% of fixed investment or 4%-8% of equipment purchase price)	
	A. Engineering and supervision (%5-%30 of direct costs)	
	B. Logal costs (%1-%3 of fixed investment)	
	C. manufacturing costs and contractors ways (%10-%20 of fixed investment)	
	D. unexpected audients (%5-%15 of fixed investment)	

Direct Investment= Direct – costs+ Indirect costs

Operational Investment = (%10-%20 of total investment)

Total Investment = fixed Investment + Operational Investment

**5.2.3. Capital Return**

This method of calculating the profit is defined as the ratio of profit to capital investment. Although, there are other ways of using the parameters of "profit" and "capital" , but the following formula containing "net-profit" and " total investment" is very common:

$$\text{Annual amount of investment} = \frac{\text{fixed investmen}}{\text{years of anortization}} + \text{annual operational costs}$$

Annual savings =annual operational costs of cooling tower- annual operational costs of air-cooled system

$$\text{Rate of capital return} = \frac{\text{Annual saving}}{\text{cost of fixed invesment} - \text{Scap value}}$$

**6. RESULTS**

Calculation of operational investment costs for air- cooled systems.

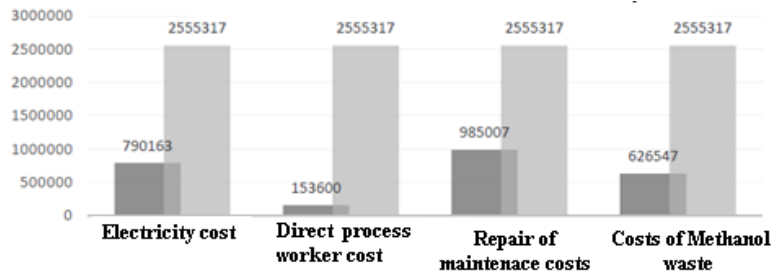

Figure 1. Annual investment cost for air-cooled system.

Alternatives suggested for substituting a water cooled exchanger system in place of an air-cooled system are as follows:

- A. Option (1): using a fresh –water cooling tower along with water desalting equipment’s.

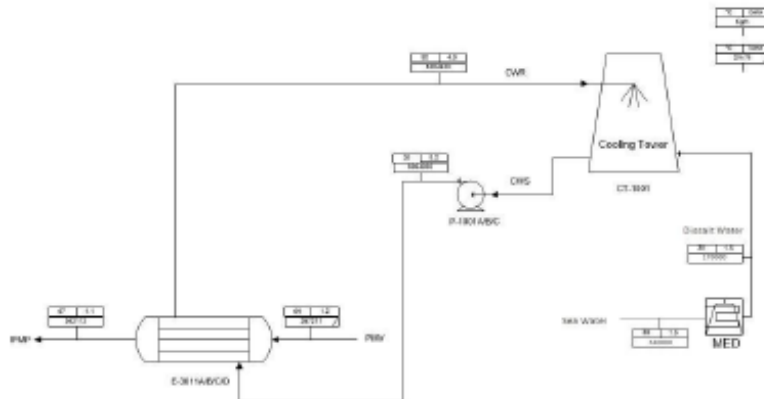

Figure 2. Process - flow diagram for fresh - water cooling tower along with water desalting equipment’s.

Energy efficiency and system optimization by replacing of water cooled condenser with air cooler in zagros petrochemical complex.\*

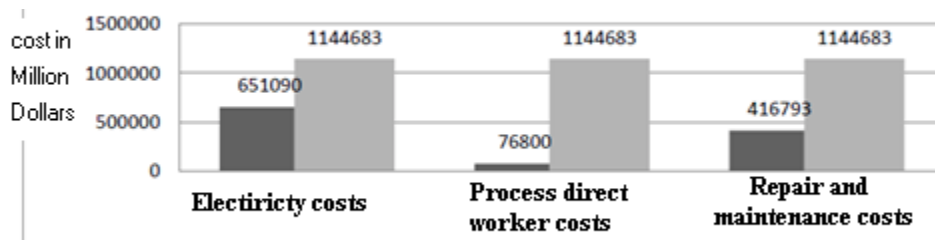

Figure 3. Operational Investment costs for a cooling tower system along with water desalting equipment's:

B. Option (2): using a fresh –water cooling tower along with compensational water supply from Mobeen petrochemical Co.

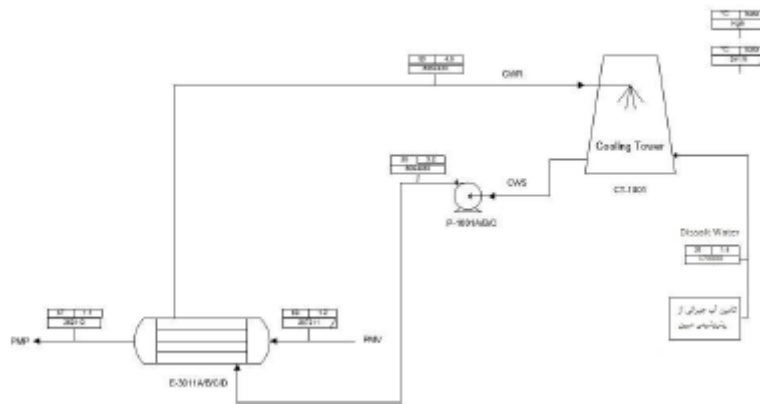

Figure 4. A diagram of process flows for fresh- water cooling Tower along with compensational water supply from Mobeen Petrochemical Co.



Figure 5. Operational Investment costs for fresh- water cooling tower (compensational water supply form Mobeen petrochemical Co).

D. Option (2): Sea- water cooling Tower system.

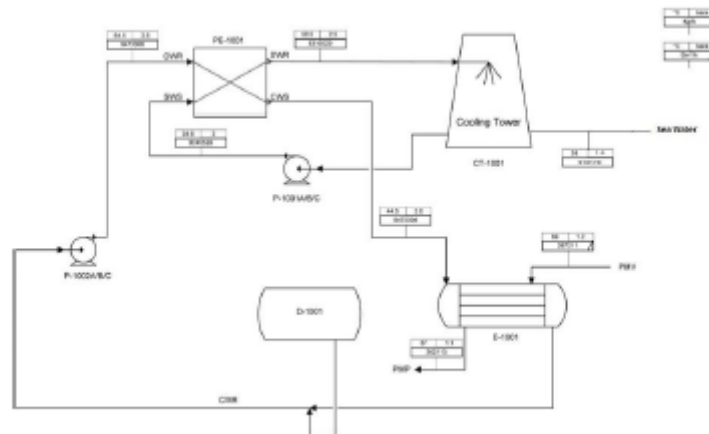

Figure 6. Process flow diagram for sea- water cooling Tower system.



Figure 7. Operational Investment Annual costs for sea-water cooling tower.

According to the diagram for operational investment annual cost presented below, the minimum annual operational cost corresponds to a configuration consisting of a fresh- water cooling tower along with water desalting equipment the project for supplying compensational water from Mobeen petrochemical company is apparently non-operational due to high costs of supply. Upon making a comparison between cooling systems designing and utilization, it becomes clear that sea-water cooling tower systems are far more expensive than fresh-water cooling towers. There are several reasons for this:

- Sea –water physical properties cause a reduction in the heat capacity of a given tower.
- The efficiency rates of Filler systems is decreased due to a high amount of solid and insoluble materials.
- The high corrosive nature of sea-water requires use of materials with high resistance against corrosion to be used in components of a cooling tower.
- The structural conditions of the tower or the basin can increase repair and maintenance costs.
- The effects of sediments produced as a result of running, can increase the costs of cleaning operations, protection, and repair of surface equipment's and tower structure near the factory.

Energy efficiency and system optimization by replacing of water cooled condenser with air cooler in zagros petrochemical complex.\*

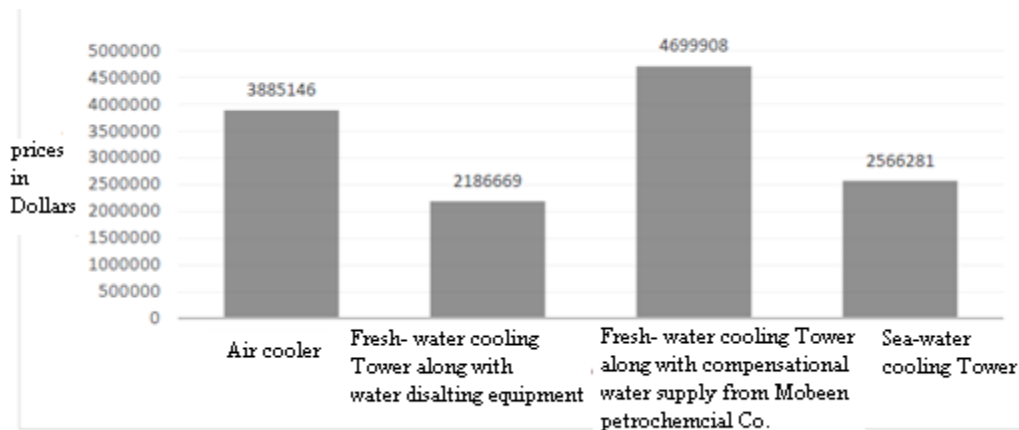

Figure 8. Annual cost of Investment.

6.1.A Comparison of Fresh-water Cooling Tower and Air Cooler

In dry systems, the rate of cooling is based on the temperature of dry bubble of environment. In other words, the minimum temperature of cooled fluid approaches the temperature of dry bubble of environment. Usually, the temperature of dry bubble is higher than the temperature of wet bubble of air. The referee, effectiveness of dry towers, especially in hot days, is less than that of wet towers.

In dry systems in which air is used as the cooling fluid, the basin for heat-transfer is the method of displacement not evaporation. Thus, in these systems, compared to wet systems, a greater volume of air should be transferred from the system. In other words, dry cooling systems require a great heat transfer surface; and that is why the dimensions of a dry system is bigger than those of a wet system.

Since the coolant fluid far an Air cooler is air, and because of low heat capacity of air (about 1.0035 Joules/g kelvin) compared to that of water (about 4.1813) , such exchangers have very low heat efficiencies .

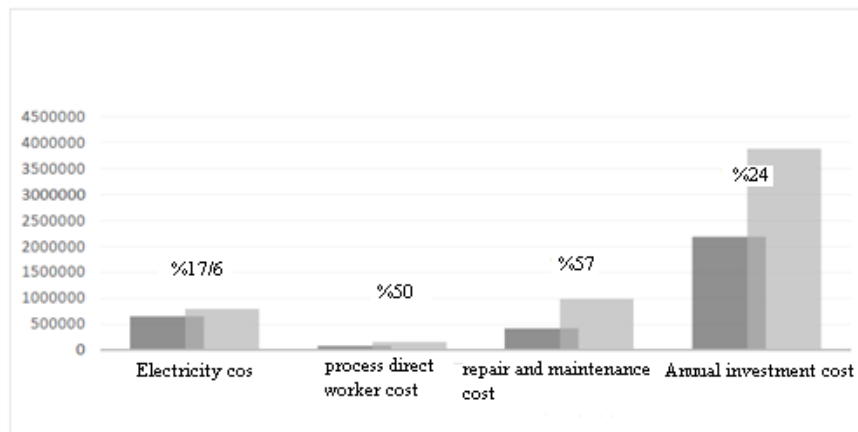

Figure 9. A comparison of investment cost for fresh –water cooling tower and air cooler.



## 7. CONCLUSION

According to above - mentioned points, a configuration consisting of a Fresh-water cooling tower along with a water desalting equipment can be introduced as a superior technology among ordinary cooling systems to be used in hot and humid regions containing reliable and continuous water resources (e.g. coasts of Persian Gulf). This is because , apart from having higher operational efficiency compared to other systems, it meets the requirements of Environment Protection as well as allowing savings of %17.6 in Electricity consumption costs, %50 in process direct worker costs, and %57 in system repair and maintenance costs . In sum, a saving of %44 in annual operational costs can be achieved.

## REFERENCES

- [1] ZareMahzabeeyeh, 2012, "systems used in Oil, gas, and petrochemical industries", comprehensive data pertonet, p1-9.
- [2] U.S. Environmental Protection Agency, 2000,"316(b) Phase II Technical Development Document", Chapter 6, Environmental Protection Agency. PP 1-12.
- [3] Ibraheemi, Gh, 2001, "Engineering of cooling towers"(wet), Tehran, Tehran univ. Office of publication and print, first publication, pages 243-269.
- [4] Peters, H.T, Translated by: Shayeghan, J &Sanayee- zadi M. 2009, "Factory Designing and economical estimation for chemical engineers", Tehran: Nu- pardazan, first publication, pp. 294-496.
- [5] McCabe W.L., Smith J.C., Herriot P, (2001), "Unit operation of chemical engineering", sixth edition, McGraw Hill, International Edition, pp.541-549 .