

Design and Finite Element Analysis of a Foldable and Single-Arm Wheelchair Lift for M-Class Vehicles

Erinç ULUDAMAR*¹

¹Adana Alparslan Türkeş Science and Technology University, Faculty of Engineering,
Automotive Engineering Department, Adana

Geliş tarihi: 10.08.2018

Kabul tarihi: 27.03.2019

Abstract

Commercially, many types of lifts and ramps are available to help the wheelchair users getting on and off the vehicles. In this study, a foldable wheelchair lift, which has a single arm was analysed by Finite Element Method according to specified maximum carrying mass of 300 kg in Directive 2001/85/EC. Examination was carried out on the manufactured wheelchair lift to validate the result of Finite Element Analysis. Initial analyses have shown that the lift is insufficient to be safe. Hence a modification was performed on the lift. After the modification, maximum von-Mises stress was calculated as 300.15 MPa in the cantilever beam of the platform which is produced by S355JR quality steel. The largest deformation was measured as 82.4 mm and 78.3 mm on the manufactured lift and on the model, respectively. Modal analysis indicates the result of the first eight modes occurred in low frequencies.

Keywords: Wheelchair lift, Finite element method, Structural analysis, Vibration

M-Sınıfı Araçlar için Katlanabilir ve Tek Kollu Tekerlekli Sandalye Asansörü Tasarımı ve Sonlu Eleman Analizi

Öz

Ticari olarak, tekerlekli sandalye kullanıcılarının araçlara girip çıkmasına yardımcı olmak için birçok asansör ve rampa mevcuttur. Bu çalışmada, tek kollu katlanabilir tekerlekli sandalye asansörü, 2001/85/EC Direktifinde belirtilen maksimum 300 kg kütleyi taşıyacak şekilde Sonlu Elemanlar Yöntemi ile analiz edilmiştir. Sonlu Elemanlar Analizinin sonucunu doğrulamak için üretilen tekerlekli sandalye asansörü üzerinde inceleme yapılmıştır. Yapılan ilk analizler, asansörün güvenli olabilmesi için yetersiz kaldığını göstermiştir. Bu nedenle asansörde değişiklik yapılmıştır. Modifikasyondan sonra, S355JR kalite çelik tarafından üretilen platformun konsol kirişinde maksimum von-Mises gerilimi 300,15 MPa olarak hesaplanmıştır. En yüksek deformasyon, üretilen asansörde ve modelde sırasıyla 82,4 mm ve 78,3 mm olarak ölçülmüştür. Modal analiz, düşük frekanslarda meydana gelen ilk sekiz modun sonucunu göstermektedir.

Anahtar Kelimeler: Tekerlekli sandalye asansörü, Sonlu elemanlar metodu, Yapısal analiz, Titreşim

*Sorumlu yazar (Corresponding author): Erinç ULUDAMAR, euludamar@adanabtu.edu.tr

1. INTRODUCTION

According to Turkish Statistical Institute survey, 12.3% of people has at least one disability in Turkey. 21.1% of the disability is constituted by orthopedically, seeing, hearing, speaking and mentally disabled and the rest 78.9% is constituted by chronic illnesses [1]. Another survey carried by Association of Social Rehabilitation which was founded in Adana city indicated that 70.3% of disabled people were expressed their dissatisfaction on the use of local public transportation including the heading of insufficient equipment in the vehicles for the disabled [2].

Accessible vehicles are important transportation means to adapt disabled people to fulfil their needs equally with other people. By public and private entities, disabled ramps and lifts has a significant effect on barrier-free access to the vehicles for wheelchair users. Therefore, different kinds of disabled lifts were developed and already in service in some public transportation means and private vehicles to tackle with transportation problems of wheelchair users.

In literature, most of the studies about wheelchair users focused on social and medical sciences [3-6]. However, few studies were concerned with the mechanical issues that wheelchair users face with. Bermond et al. [7] performed crash tests according to different vehicle categories to observe possible failures in safety systems which are used by wheelchair users. Studies with finite element analysis on resemble models in this study is widespread in literature. Kalyanasundaram et al. [8] investigated wheelchair wheel with the aid of finite element analysis (FEA). They compared the result according to weight, moment of inertia, surface area and wheel stiffness. Fatigue life investigation of a heavy vehicle rim was analysed by using finite element (FE) by Topaç et al. [9]. They considered the load is radial and solved the problem under this force.

Mechanical issues of different problems were concerned for various structural analysis carried out by FEM. Han et al. [10] investigated the vibration characteristic of a coach when its engine

is in idle condition. They found out that the main vibration transmitted from the engine to the chassis frame since resonance formed between engine idle frequency and the fourth natural frequency of the chassis frame.

Chandru and Suresh [11] compared a car roof with and without dampers via FEM. Furthermore, they compared the results experimentally. They concluded the study as less frequency occurred with damper. Seat construction of a vehicle were performed by Ozcanli and Dede [12] via FEA. They optimized the thickness of seat frame by advanced steel to reduce the weight of the construction. Araujo et al. [13] carried out numerical and experimental study on a wind turbine. At the results of modal analysis, the differences between the methods could be more than 15%. Wei et al. [14] calculated vibration modes and frequencies on a single tower double cable plane bridge by FEM. They found out that the first period time is 2.95919 s and the first torsion frequency of the bridge was 0.43574 Hz. In the study of Wang et al. [15] fracture analysis of the main shaft of a wind turbine was performed by FEM. According to analysis result, structure improvement processes were carried out including surface treatment and heat treatment, and local structure improvement.

Having single arm and foldable wheelchair lifter provides quite good advantage in daily use since this type of wheelchair lifter leaves the door entry open for non-disabled people and for loading and unloading goods. Moreover, they occupy less interior space. However, this type of lifts has also some drawbacks. Since the lift has a single arm the user and his/her wheelchair weight and the own weight of the lift must be carried by a single arm. Therefore, the construction of single-arm wheelchair lifts has less lifting capacity than dual-arm wheelchair lifts and they tend to be statically and dynamically imbalance. Therefore, the platform itself can dangerously lean on the non-armed side. This can be result with roll over or sliding on the platform of wheelchair.

Due to the tough competition and increasing customer demands in automotive sector, sub-

industry of automotive sector is under the pressure of manufacturing reliable, easy use, low cost and efficient products. In this study, one of the vehicle parts that was generally manufactured by sub-industry of automotive sector investigated via FEA. A single-arm and foldable wheelchair lifter which can be set up inside a M-class vehicle type which was manufactured in accordance with the Directive 2001/85/EC of the European Parliament was examined structurally. For this, FEA carried out to investigate the wheelchair lift behaviour under the load that specified in the Directive. The deformation of the wheelchair lift was compared with the manufactured one to validate the result of FEA. Moreover, Due to assemble of the parts, some bouncing and smashing of lift parts may occur with each other. Hereby, modal analysis of

the structure was also investigated with finite element analysis.

2. MATERIAL AND METHOD

Firstly, in order to form 3D model of the wheelchair lift, parts were created as solid bodies. Assembly of the lift were created via the solid bodies. Accordingly, solid meshing was performed in FE. Before the meshing operation, materials of the structure were entered to the library by considering the mechanical properties of S235JR and S355JR quality steel. The mechanical properties of the steel were given in Table 1. S355JR quality steel was used in platform's beam. Whereas, S235JR quality steel was used in rest of the steel part of the wheelchair lift.

Table 1. Mechanical properties of the material

Material type	Mechanical Property	Value	Unit
S235JR	Density	7850	kg/m ³
	Young Modulus	2x10 ⁵	MPa
	Poisson's Ratio	0.3	-
	Tensile Yield Strength	235	MPa
	Compressive Yield Strength	235	MPa
	Tensile Ultimate Strength	460	MPa
	Compressive Ultimate Strength	460	MPa
S355JR	Density	7850	kg/m ³
	Young Modulus	2.1x10 ⁵	MPa
	Poisson's Ratio	0.3	-
	Tensile Yield Strength	355	MPa
	Compressive Yield Strength	355	MPa
	Tensile Ultimate Strength	520	MPa
	Compressive Ultimate Strength	520	MPa

Boundary conditions were taken into consideration to simulate the wheelchair platform reach to the widest point from the base surface which is fixed inside the vehicle in service application. The load is applied as 300 kg specified in the directive of 2001/85/EC. The own weight of the lift and the forces from cylinder were also added to the model as boundary conditions. 4000 N forces were applied at the connections of hydraulic cylinder. Furthermore, six-degree of freedom of the body part which mounted inside the vehicle was fixed from the lower surface in order to simulate the service conditions. In meshing operation Hex-dominant meshing and quadratic-tetrahedrons elements with 1.20 growth rate were applied. Sweep mesh operation was carried out in

sweepable bodies. Additionally, quality of meshes were improved at critical areas.

The results of analysis were validated with the disable lift which was manufactured according to dealt design through this study. The deformations on the platform was measured from the lowermost point of the arm in lateral direction and from the endmost edge with respect to the supporting arm in vertical direction to validate the results. The FEM software calculate the forces as specified in Eq. (1).

$$[K]\{x\}=\{F\} \quad (1)$$

Where; K are the spring constants that is calculated by small deflection theory, x is the displacements

and F are the statically applied loads.

High attention should be paid on natural modes and natural frequencies of the multi-degree of freedom systems. If excitation frequencies and natural frequencies of a system is almost the same, the machine can damage [16]. To find natural frequencies and natural modes of a system eigenvalues and eigenvectors should be calculated by setting the determinant to zero value.

The systems are generally characterized by its own weight (m), damping (c), stiffness (k), and excitation force $F(t)$.

The equation of motion of the systems can be written as:

$$m\ddot{x}(t)+c\dot{x}(t)+kx(t)=F(t) \quad (2)$$

In the design no damper introduced in the lift. Additionally, in the analysis, damping of the materials are neglected. By this means, the second term of Eq. (2) is subtracted from the equation. In modal analysis, the platform is considered as loaded steadily since the behaviour of the lift is more important when a person is onto it. Therefore, 300 kg mass is added as distributed mass onto the platform. Thus, vibration is considered as free vibration and the Eq. (2) becomes:

$$m\ddot{x}(t)+kx(t)=0 \quad (3)$$

By introducing boundary conditions $x(0) = \dot{x}_0$ and $\dot{x}(0) = \ddot{x}_0$ the form of the Eq. (3) becomes:

$$\ddot{x}(t)+\omega_n^2x(t)=0 \quad (4)$$

$$\text{Where } \omega_n = \sqrt{\frac{k}{m}} \quad (5)$$

Solution of Eq. (4) is:

$$x(t)=A \sin (\omega_n t+\varphi) \quad (6)$$

Where A is the amplitude express with

$$A=\sqrt{\left(\frac{\dot{x}_0}{\omega_n}\right)^2+x_0^2} \quad (7)$$

and phase angle expresses with

$$\varphi=\tan^{-1} \frac{x_0 \omega_n}{\dot{x}_0} \quad (8)$$

Kinematically independent coordinates should be considered in a multiple degree of freedom systems. Thus, equations can be expresses in a matrix form.

In finite element method, Ansys software solves the equation by using matrices as:

$$([K]-\omega_i^2[M])\{\varphi_i\}=0 \quad (9)$$

The system's first eight natural frequencies and mode shapes was calculated in FEA. The lift was modified during the examination. The modification was applied both on 3D model and on the manufactured one. Validation of the results were carried out after the modification of the lift. The manufactured lift as final prototype was illustrated in Figure 1.



Figure 1. View of the manufactured lift as unfolded

3. RESULT AND DISCUSSION

Under the applied boundary conditions, FEA specified that the maximum von-Mises stress occurred on the platform beam right next to the hinge that used for folding the platform. Therefore, two plates were welded under the cantilever beam to support the fold-side beam of the platform. As a result, 7% reduction of maximum von-mises stress

was calculated on the beam. The figures which illustrate the von-Mises stress distribution was shown in Figures 2 and 3. Figure 2 shows the von-

Mises stress distribution without the welded plates and Figure 3. illustrates the stress disturbing when the plates were added to the lift.

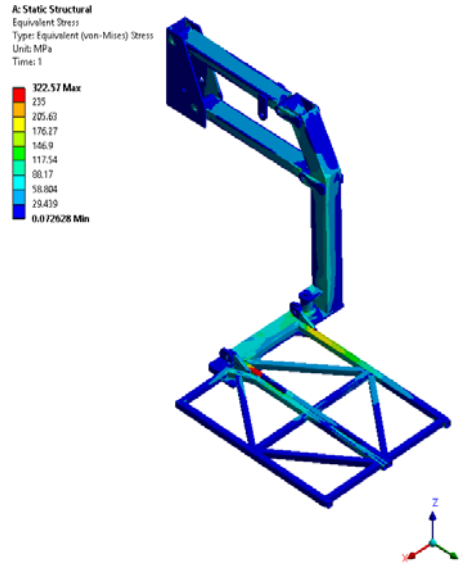

Figure 2. Von-Mises stress distribution on unmodified lift

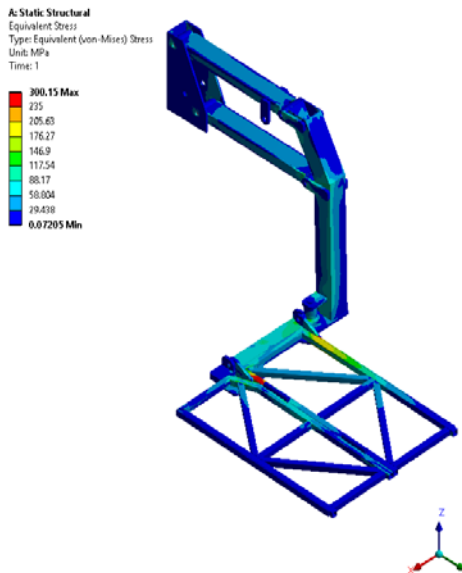

Figure 3. Von-Mises stress distribution on modified lift

The rest of the results were evaluated on modified model since the lift is unable to operate safely without the modification. The same parts were also

welded to the manufactured wheelchair lift. The results were evaluated on modified lift.

On the manufactured system the measured deformation was 82.4 mm on the endmost edge with respect to the supporting arm in vertical direction and 17.1 mm on the lowermost point of the arm in lateral direction. The same deformation was calculated as 78.3 mm and 16.9 mm respectively in numerical analysis which is

adequately close to the value in real-world. The deformation on numerical model was shown in Figure 4 and Figure 5. In the figures, wireframe illustrates the undeformed body. The deformation view of the model was magnified three times in the figures. After the validation of numerical analysis, further investigation was carried out.

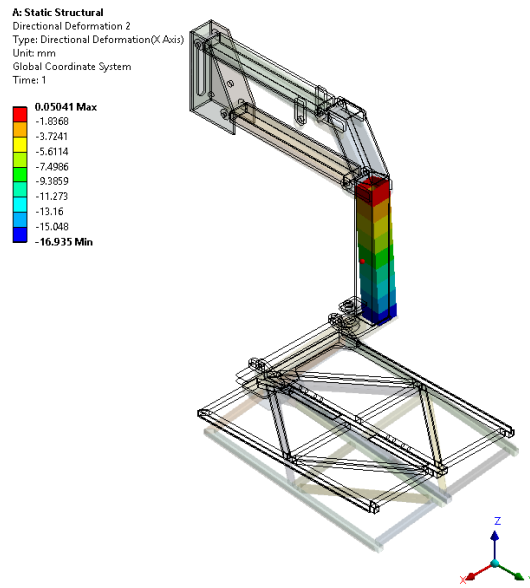

Figure 4. Deformation of the arm in lateral axis

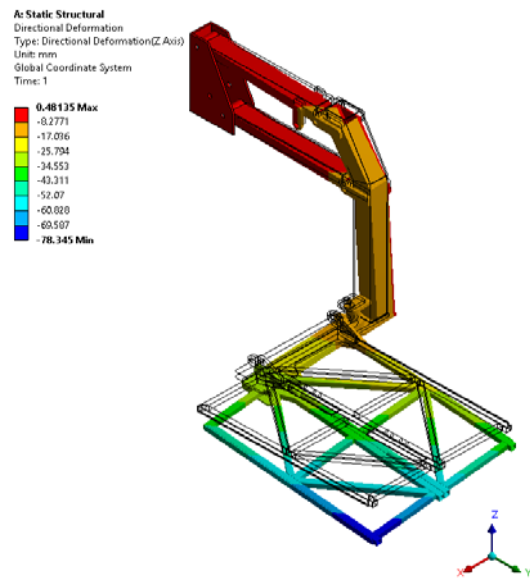

Figure 5. Deformation of the lift in vertical axis

Mode analysis indicated that the natural frequencies are occur at low frequencies. The frequencies of first eight modes were given in Table 2. In Figures 6-13 mode shapes of the wheelchair lift were illustrated with a hundred times magnified deformation view. If the natural frequency coincidence with operation frequency, stiffness or weight would be changed to shift the natural frequency of the lift to avoid resonance [10]. At the first three eigenfrequencies, the arm of the lift was characterized the movement of the lift. The other eigenfrequencies, there were the movements of platform with higher maximum amplitude than the first three eigenfrequencies.

Table 2. Mode Results

No	Frequency (Hz)	Maximum amplitude (mm)
1	1.9116	2.545
2	2.3436	2.9417
3	5.3313	2.952
4	7.6473	3.7212
5	8.047	4.0088
6	17.762	2.9742
7	19.428	6.2077
8	21.644	4.9195

B: Modal
Total Deformation
Type: Total Deformation
Frequency: 1.9116 Hz
Unit: mm

2.545 Max
2.2622
1.9794
1.6966
1.4139
1.1311
0.84892
0.56554
0.28277
0 Min

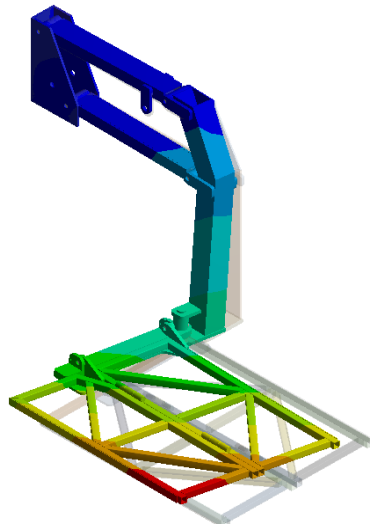

Figure 6. Deformation at mode 1

B: Modal
Total Deformation 2
Type: Total Deformation
Frequency: 2.3436 Hz
Unit: mm

2.9417 Max
2.6148
2.288
1.9611
1.6343
1.3074
0.98055
0.6537
0.32685
0 Min

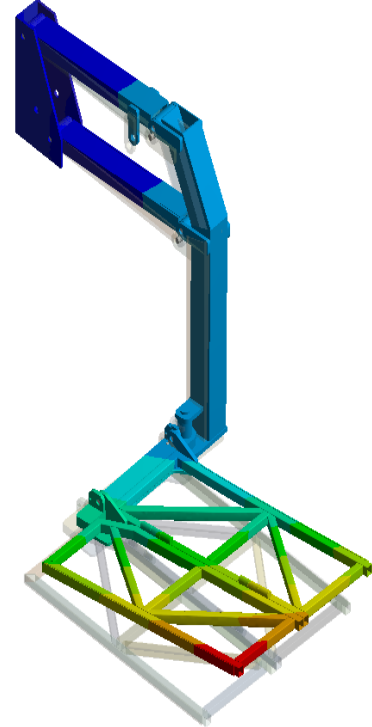

Figure 7. Deformation at mode 2

B: Modal
Total Deformation 3
Type: Total Deformation
Frequency: 5.3313 Hz
Unit: mm

2.952 Max
2.624
2.296
1.968
1.64
1.312
0.98401
0.65601
0.328
0 Min

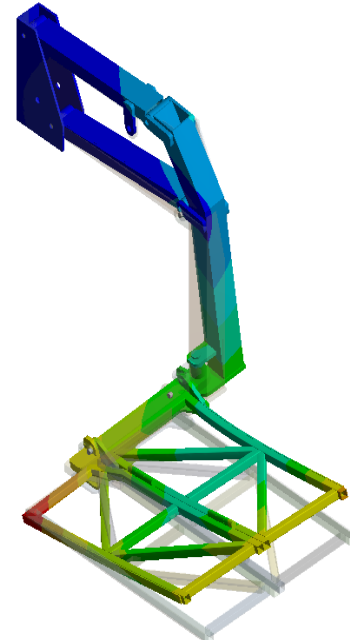

Figure 8. Deformation at mode 3

B: Modal
 Total Deformation 4
 Type: Total Deformation
 Frequency: 7.6473 Hz
 Unit: mm

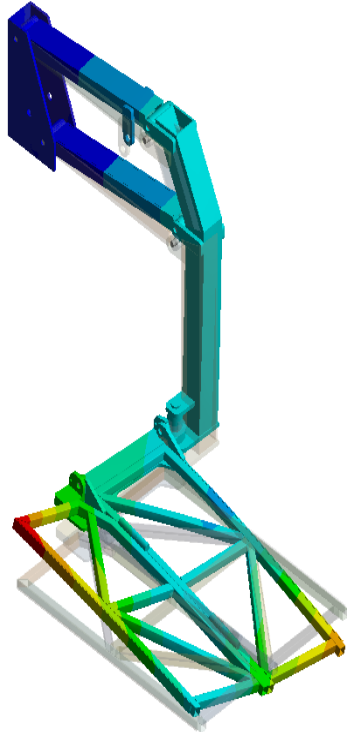
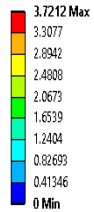

Figure 9. Deformation at mode 4

B: Modal
 Total Deformation 6
 Type: Total Deformation
 Frequency: 17.762 Hz
 Unit: mm

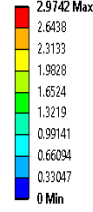

Figure 11. Deformation at mode 6

B: Modal
 Total Deformation 5
 Type: Total Deformation
 Frequency: 8.047 Hz
 Unit: mm

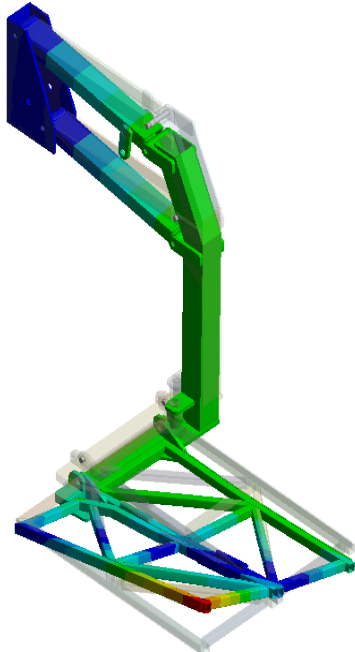
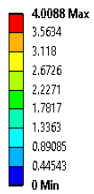

Figure 10. Deformation at mode 5

B: Modal
 Total Deformation 7
 Type: Total Deformation
 Frequency: 19.428 Hz
 Unit: mm

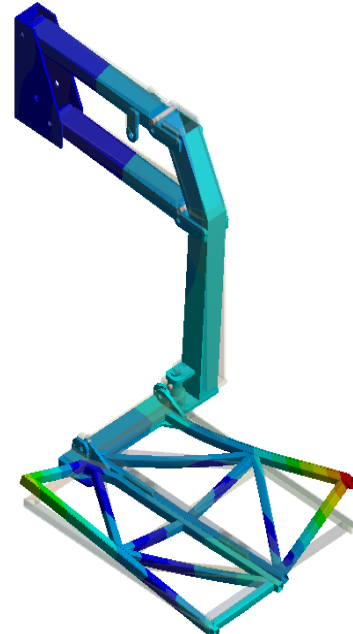
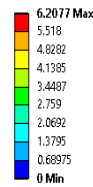

Figure 12. Deformation at mode 7

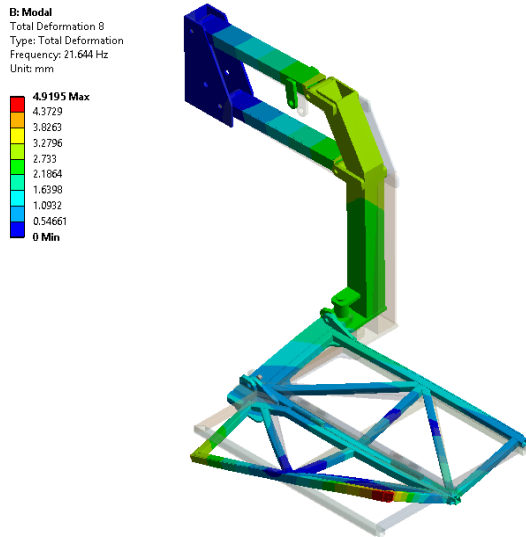

Figure 13. Deformation at mode 8

4. CONCLUSION

The objective of this study was to investigate a foldable single-arm wheelchair lift. Throughout the study, structural behaviour of the lift was evaluated with finite element methods. The outcome results obtained from FEA was validated with the manufactured lift. Before the evaluation, static analysis indicated that the manufactured lift had not been safe enough, thus a modification was carried out before further investigation. Two plates were added under the platform beams where they mate together.

According to experiments and results, following summarises were brought out:

By modification on the lift, maximum von-Mises stress which occurred on the platform beam right next to the hinge was reduced 7%. As a result, maximum von-Mises stress was calculated as 300.15 MPa. Deformation of the lift was close enough to validate the FEA results with experimental result on manufactured lift. 82.4 mm on the endmost edge with respect to the supporting arm in vertical direction and 17.1 mm on the lowermost point of the arm in lateral direction was measured on the manufactured lift whereas 78.3 mm and 16.9 mm deformations were

calculated in numerical analysis, respectively. The results of FEA showed that first natural frequency occurred at 1.9116 Hz and the highest was 21.644 Hz. The arm of the lift was characterized the movement at the first three eigenfrequencies, whereas there were the movements of platform at other eigenfrequencies.

5. REFERENCES

1. Turkish Statistical Institute, 2002. Turkey Disability Survey, Ankara. (Cm 2913).
2. Association of Social Rehabilitation, 2013. Current Status of the Disabilities and Life Satisfaction Survey. [online] http://www.trder.org/download/local_activities_output/12-%20Engelli%20Anketi%20%C3%87a1%C4%B1%C5%9Fmas%C4%B1.pdf (Accessed 24 April 2018).
3. Stillman, M.D., Bertocci, G., Smalley, C., Williams, S., Frost, K.L., 2017. Healthcare Utilization and Associated Barriers Experienced by Wheelchair Users: A Pilot Study, *Disability and Health Journal*, 10(4), 502–508.
4. Hiremath, S.V., Intille, S.S., Kelleher, A., Cooper, R.A., Ding, D., 2015. Detection of Physical Activities Using a Physical Activity Monitor System for Wheelchair Users, *Medical Engineering and Physics. Institute of Physics and Engineering in Medicine*, 37(1), 68–76.
5. Gaete-Reyes, M., 2015. Citizenship and the Embodied Practice of Wheelchair Use, *Geoforum*, 64, 351–361.
6. Davison, P., Sharpe, M., Wade, D., Bass, C., 1999. Wheelchair Patients with Nonorganic Disease: A Psychological Inquiry, *Journal of Psychosomatic Research*, 47(1), 93–103.
7. Bermond, F., Attali, X., Dolivet, C., 2010. Floor Anchorage Load and Safety Space for Adult Wheelchair Users During a Crash, *Irbm*, 31(5–6), 289–298.
8. Kalyanasundaram, S., Lowe, A., Watters, A. J., 2006. Finite Element Analysis and Optimization of Composite Wheelchair Wheels, *Composite Structures*, 75(1–4), 393–399.
9. Topaç, M. M., Ercan, S., Kuralay, N. S., 2012.

- Fatigue Life Prediction of a Heavy Vehicle Steel Wheel under Radial Loads by Using Finite Element Analysis, *Engineering Failure Analysis*, 20, 67–79.
10. Han, T., Huang, C., Tan, A.C.C., 2014. Experimental and Finite Element Analysis to Identify the Source of Vibration of a Coach, *Engineering Failure Analysis*, 44, 100–109.
 11. Chandru, B. T., Suresh, P. M., 2017. Finite Element and Experimental Modal Analysis of Car Roof with and without Damper, *Materials Today: Proceedings*, 4(10), 11237–11244.
 12. Ozcanli, M., Dede, G., 2018. Evaluation of Advanced Steel Usage on Seat Construction to Reduce Bus Weight in Compliance with FMVSS and APTA Regulations, *International Journal of Heavy Vehicle Systems*, 25, 235-247.
 13. Araújo, D.C., e Castro, L.C., Shzu M.A.M., Avila, S.M., de Morais, M.V.G., 2017. Modal Identification of a Wind Turbine, *Procedia Engineering*, 199, 2250–2255.
 14. Wei, L., Cheng, H., Li, J., 2012. Modal Analysis of a Cable-Stayed Bridge, *Procedia Engineering*, 31, 481–486.
 15. Wang, R., Han, T., Wang, W., Xue Y., Fu D., 2018. Fracture Analysis and Improvement of the Main Shaft of Wind Turbine Based on Finite Element Method. *Advances in Mechanical Engineering*, 10(4), 1-9.
 16. Weis, P., Kucera, L., Pechac, P., Mocilan, M., 2017. Modal Analysis of Gearbox Housing with Applied Load, *Procedia Engineering*, 192, 953–958.