

REHABILITATION OF HIGH STRENGTH REINFORCED CONCRETE CORBELS USING BASALT FIBER FABRIC

Adnan Hazem Alshawaf
Gaziantep University, Civil Engineering Department
eng_shawaf@hotmail.com

Mehmet Eren GÜLŞAN
Gaziantep University, Civil Engineering Department
gulsan@gantep.edu.tr

Khamees Nayyef Abdulhaleem
Gaziantep University, Civil Engineering Department
khamees.abdulhaleem@mail2.gantep.edu.tr

ABSTRACT: This paper presents an experimental study on the mechanical behavior of damaged reinforced concrete corbels rehabilitated by Basalt Fiber Fabric (BFF). The main research aim of the study is to investigate the effectiveness of basalt fiber fabric on rehabilitation of reinforced concrete corbels, which were damaged because of elevated temperatures and overloading, by examining load restoring capacity and ductility. Totally nine corbels that had been damaged before were selected for the study. The initial failure of the corbels had been because of overloading after heating them to several temperature levels (250°C, 500°C, and 750°C). These corbels had been produced from high strength self-compacting concrete with one concrete class (80 MPa) and three different amounts of steel fiber ratios (0%, 0.5%, 1%). However, shear span value for all corbels is same (90 mm). Experimental results show that use of basalt fiber fabric on damaged corbels increases the load carrying capacity and ductility significantly as compared to the corresponding values of corbels before initial failure. Besides, the stiffness of the corbels after rehabilitation is same with the stiffness of them before initial failure. Moreover, all of the rehabilitated corbels failed because of de-bonding failure mode and no visible damage was observed on the fabric.

Key words: corbels, high strength concrete, rehabilitation, basalt fiber fabric, epoxy.

INTRODUCTION

Corbels are short cantilever deep beam with a shear span, structural members commonly used in reinforced concrete and Precast concrete structures. As known, the corbels are widely used in industrial buildings and highway bridges. The main function for the corbels are transferring the vertical and horizontal loads between members such as the beams to columns and walls (Foster & Malik, 2002; Foster, Powell, & Selim, 1996; Hwang & Lee, 2002; Russo, Venir, Pauletta, & Somma, 2006; Yong & Balaguru, 1994) . The strength and stiffness for reinforced concrete corbels could be affected if the corbels are exposed to heat treating. Previous experimental

studies concrete behavior under high temperatures have mostly focused on the reduction of stiffness and strength properties (Toumi, Resheidat, Guemmadi, & Chabil, 2009). In order to maintain the structural members from degradation or loss the main function for this member, the researchers were investigated rehabilitation methods and a mechanism to maintain those members. However, many reasons demand to rehabilitate concrete structures not just heat treatment such as, use consideration (change in loading requirements), environmental conditions, construction and material shortcomings (incorrect placing of steel bars, redesign the members, inadequate lap length at splice or inadequate transversal reinforcement like; hoops, ties, or stirrups, and weak constructions practice (Elgwady, Rabié, & Mostafa, 2005) . As well as, structural rehabilitation's is play a role in civil engineering, to rectify damaged, corroded and old reinforcement concrete structures in common terms likewise repairing, rehabilitating and strengthening with this in mind processes related to damage ratio (Kumar, Selvamony, Seeni, & Sethuraman, 2015). The variation in rehabilitate and other methods for repairing reinforcement concrete isn't so much obvious, because a lot of reason may cause failure in concrete such as overloading. On other circumstance, crack observed in the concrete so if the corbels is undamaged and the structure live load is to be increased, then the appliance is merely for strengthening functions (Corry & Dolan, 2001). While The most important factors for using composite materials is strengthening the structure. To give an illustration, the data elucidate repair or strengthening techniques for reinforced concrete corbels by Basalt fiber fabric are very limited and almost nonexistent, another key thing to remember many researchers investigates on basalt fiber reinforced polymer composites ,the study confirm when basalt fiber had been used the fracture toughness increases as a result of reinforcing , the toughness of the composite increased compared to the matrix (BFP) and loading capacity (Czigány, Vad, & Pölöskei, 2005; Kumar et al., 2015; Liu, Shaw, Parnas, & McDonnell, 2006) . Moreover, on other hand researchers investigates strengthening on reinforced concrete corbels by utilizing carbon fiber (CFRP) and they found by using CFRP technology for strengthening and repairing reinforced concrete corbels was operative and efficient too (Ahmad, Elahi, Kundi, & Haq, 2013; Erfan, Abdel-Rahman, Nassif, & Hammad, 2010; I Ivanova & Assih, 2015; Ivelina Ivanova & Assih, 2015; Ivelina Ivanova, Assih, & Dontchev, 2016) .

This paper presents results of an investigation on the experimental behavior of heated and damaged steel fiber Reinforced corbels after rehabilitated using basalt fiber fabric and to Figure out the change between the ultimate load and the failure mode after the rehabilitation.

EXPERIMENTAL WORK

The experimental study consists of nine corbels. All of the damaged corbels had been produced from self-compacting high-strength steel fiber reinforced concrete (compressive strength value of 80 MPa). While all corbels have the same shear span ratio (0.69) and reinforcement ratio (0.0158), they contain different amount of steel

fiber (0%, 0.5%, and 1%). Moreover, all corbels had been damaged before rehabilitation process because of overloading after different heating levels (temperature values of 250°C, 500°C, and 750°C). After the damaged corbels were rehabilitated by basalt fiber fabric, they were reloaded until failure. All details about the rehabilitation of corbels and testing procedure are explained in the following parts.

Corbel details

All corbels have the same geometry and steel reinforcement arrangement which are shown in Fig. 1. The cross-section dimensions of both column and corbels are 150mm x 150mm. Column part of the column had been reinforced with four 10 mm diameter steel bars for longitudinal reinforcement and of four 8 mm diameter steel bars for stirrups. Besides, two 14 mm diameter deformed steel bars were used for the main reinforcement of all corbels and the concrete cover distance for all corbels is 20 mm. All corbels were supported by roller supports during loading tests.

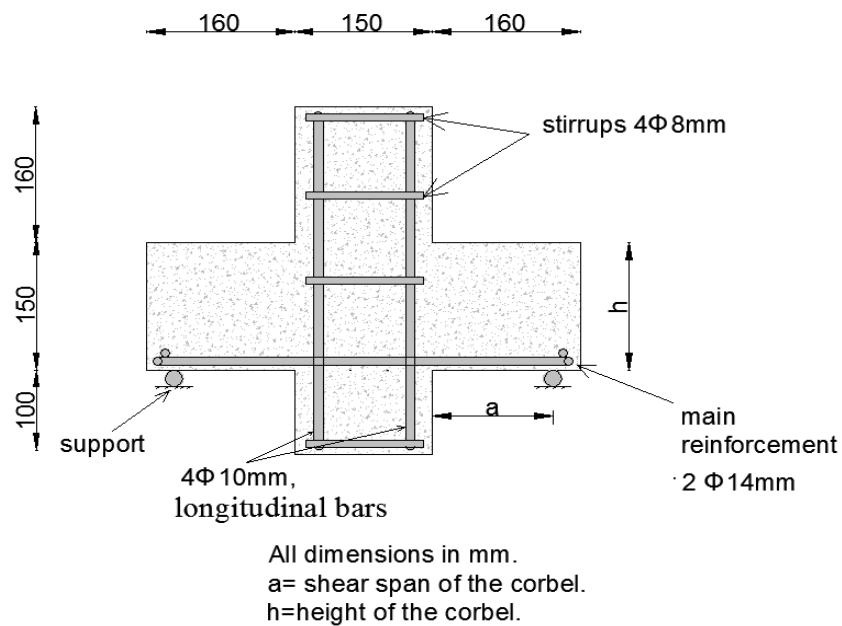

Figure 1. Corbel detail

Materials properties

In this experimental study, three types of epoxy were used. Each one was preferred for a different purpose in the rehabilitation process. High viscosity epoxy adhesive (TEKNOBOND 200) was used both for the repair of damaged concrete parts and for closing the cracks on the corbel surface in order to prevent leakage of crack repair material. Low viscosity epoxy adhesive (TEKNOBOND 300 TIX) was used for gluing the basalt fiber fabric to the concrete surface. The mechanical and physical properties of the high and low viscosity epoxy adhesives are shown in Table 1.

Table 1. The properties of high and low viscosity epoxy adhesive

Density (gr/cm ³)	Consumption (kg/m)		Bond Concrete (N/mm ²)	to Pot Life (min)	Loading capability (day)	Full strength (day)	Application Ground Temperature (°C)
low viscosity epoxy	1.15			45	1	7	5-30
	A 1.05	2	5.3				
high viscosity epoxy	1.50	1.5	4	30	1	7	5-30

The third type of epoxy was very low viscosity injection resin (Sikadur-52) which was used as crack repair material. It was injected to the inner micro cracks in as much of his flowability in order to close all cracks both inside the corbels and on the corbel surface. The properties of this epoxy are shown in Table 2.

Table 2. The properties of very low viscosity injection resin

Density (kg/l)	Compressive Strength (N/mm ²)	Bond to Concrete (N/mm ²)	Pot Life (min)	Flexural Strength (N/mm ²)	Tensile Strength (N/mm ²)	E-Modulus (N/mm ²)
1.1 A 1 B	52	4	25	61	37	1800

The most important material of the study is basalt fiber fabric (BFF). Unidirectional basalt fiber fabric was treated for the rehabilitation of the damaged corbels. Reasons for the selection of this fabric type can be listed as a high tensile strength, smooth texture, durability, fire resistance and cheapness as compared to other alternatives (such as carbon fiber fabric). The properties of the fabric are shown in Table 3.

Table 3. The properties of basalt fiber fabric

Tensile Strength (MPa)	Tensile Modulus Elasticity (Gpa)	of Elongation (0/0)	Thickness (mm)	Polyester Yarn Density (tex)	Area Weight (g/m ²)
2100	105	2.6	.115	5.25	300

Rehabilitation methods

The grinder machine was used to clean the surfaces of corbels. The top four corners were rounded to achieve the continuity in the rehabilitated system, to prevent stress concentrations and to avoid tearing in basalt fabric. Before the gluing operation, the

air compressor was used to remove any loose particles or dust on the surface. High viscosity epoxy adhesive was used for closing the big cracks in order to prevent the leakage of very low viscosity crack repair epoxy and to substitute the loosening parts of the damaged corbels. Thereafter, the cracks and voids were filled out with very low viscosity crack repair epoxy. The repair epoxy was injected to the inner of corbels by small injection needles and gravity feed method was used for the injection process. After injection process, the corbels were left for seven days to achieve the target strength of the repair epoxy. Application of the first part of the rehabilitation process in order to repair the cracks is shown in Fig. 2 step by step.

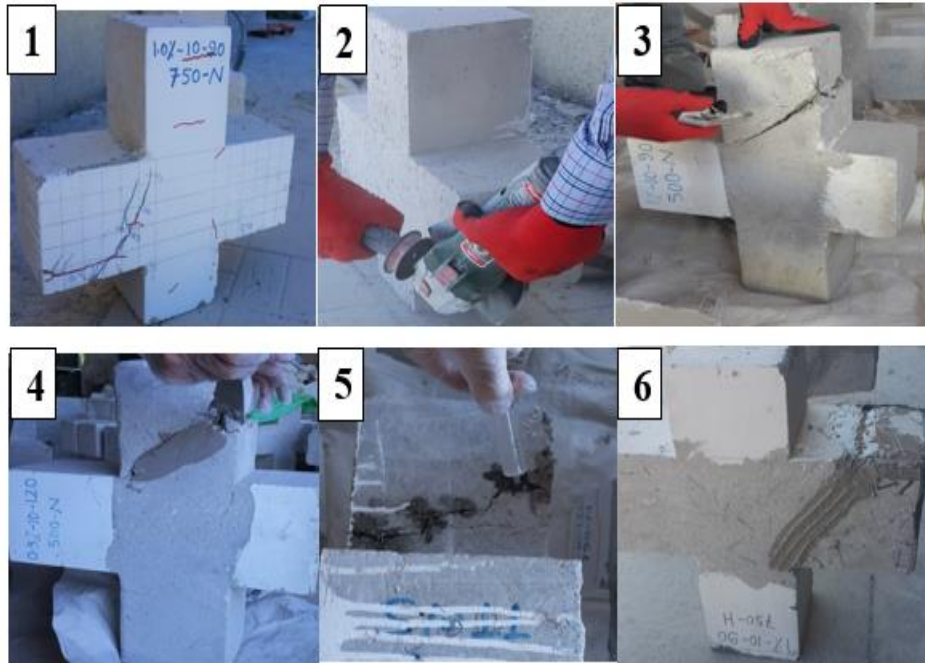

Figure 2. Configuration steps of preparation surface and injecting with very low viscosity injection

In the second part of the process, three strips of basalt fiber fabric were cut in specific dimensions for all corbel specimens. Components of low viscosity epoxy (epoxy and hardening resin) are mixed by electric drill machine according to low viscosity epoxy adhesive product data sheet. Thereafter basalt fiber fabric was saturated with the low viscosity epoxy and the saturated fabrics were glued to the corbel surface. The fabric was glued to the surface according to the shape and geometry of the corbels. Moreover, escaping from the voids is very important during gluing process. Therefore, trowel was used to eliminate air voids and to achieve successful connection between the fabric and the surface. Since basalt fiber fabric is unidirectional, it was glued to the corbel surface in both vertical and horizontal directions in order to resist normal stresses existing in both directions. Lastly, grinder machine was used again to level bottom of corbels in order to achieve smooth and homogeneous load transfer mechanism during loading. Step by step implementation of the second part of the rehabilitation process is shown in Fig. 3.

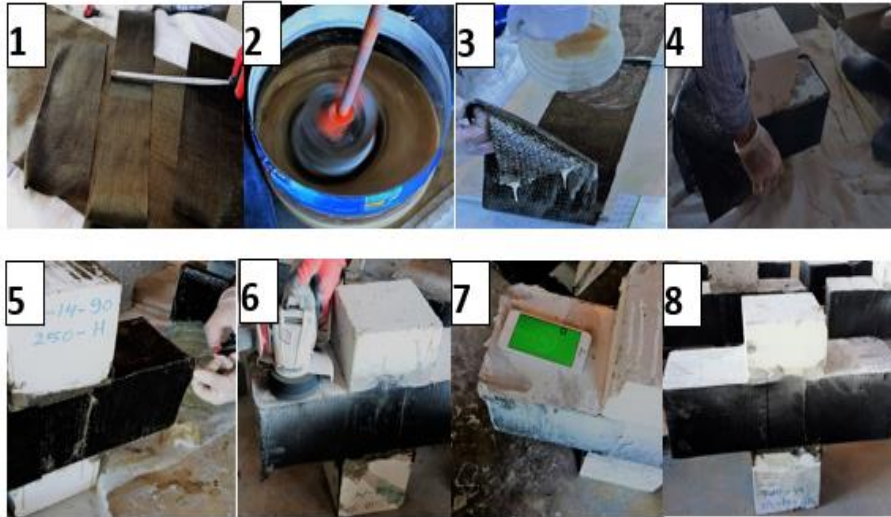

Figure 3. Configuration steps of the bonding surface and applying the Basalt fiber fabric with epoxy

Test Setup

All corbels were tested before and after the rehabilitation process under three-point loading tests Figure 4. Tests were carried out via 500 kN capacity displacement-controlled loading machine. The corbels were loaded with rate of 0.3 mm/min. Deflection of corbels was measured by two linear-variable-displacement-transducers (LVTDs). Load and displacement values were recorded at every 0.2seconds.



Figure 4. Corbel Specimen Setup

EXPERIMENTAL RESULTS AND DISCUSSION

Loading test results with all details are shown in Table 4. The first column in the table names designation for the corbels, including all related values, in which six different terms are provided for each corbel's name; the first term represents the

number of the specimen and the remain terms represent compressive strength, steel fiber ratio, main bar diameter, degree of heating before initial failure, and shear span length, respectively. As a result of tests, it was concluded that load capacity of the high strength reinforced concrete corbels increased an amount of 50% averagely as compared to the corresponding values before rehabilitation. Moreover, strengthening with basalt fiber fabric enhanced the ductility of corbels noticeably. Therefore, a preferable seismic performance of reinforced concrete corbels can be achieved with basalt fiber fabric even they are damaged due to both fire and overloading. Besides, the failure modes of the corbels before and after rehabilitation are summarized in Table 4. All of the corbels have the same failure pattern after repairing which is debonding between the basalt fiber fabric and the surface of corbels as shown in Fig. 5. Even different failure modes had been observed in the initial failure of the corbels, failure modes of all corbels after rehabilitation were debonding failure. This result can be attributed to the placement of the fabric in two directions which makes the fabric much more powerful leading to prevention of the tearing of the fabric.

Table. 4 Details of rehabilitated corbels

Name	Max. Carrying load before Rehabilitation PU (KN)	Max. Carrying load After Rehabilitation *PU (KN)	*PU/PU	Max. Deflection(mm) At Failure Load (Before the Rehabilitation)	Max. Deflection(mm) At Failure Load (After the Rehabilitation)	Mode of failure before the Rehabilitation	Mode of failure after the Rehabilitation
C0-80-0.0-14-250-90	268	292.5	1.09	0.744	4.443	Shear failure	De-bonding
C1-80-0.0-14-500-90	210	246.5	1.17	1.654	3.60	Diagonal splitting	De-bonding
C2-80-0.0-14-750-90	113	150	1.32	1.231	7.583	Shear failure	De-bonding
Table 4 Details of rehabilitated corbels (Continued)							
C3-80-0.5-14-250-90	370	399.6	1.08	1.60	7.3	Shear failure	De-bonding
C4-80-0.5-14-500-90	251	262	1.04	2.309	6.292	Shear failure	De-bonding
C5-80-0.5-14-750-90	134	201	1.50	1.654	3.69	Shear failure	De-bonding
C6-80-1.0-14-250-90	382	430.3	1.13	2.048	6.125	Shear failure	De-bonding
C7-80-1.0-14-500-90	294	306	1.04	2.329	3.805	Shear failure	De-bonding
C8-80-1.0-14-750-90	183	187.5	1.02	1.68	6.886	Shear failure	De-bonding



Figure 5. Specimen with De-bonding failure

Figure 6 shows the Load-Deflection relationships that came from testing of injected corbels.

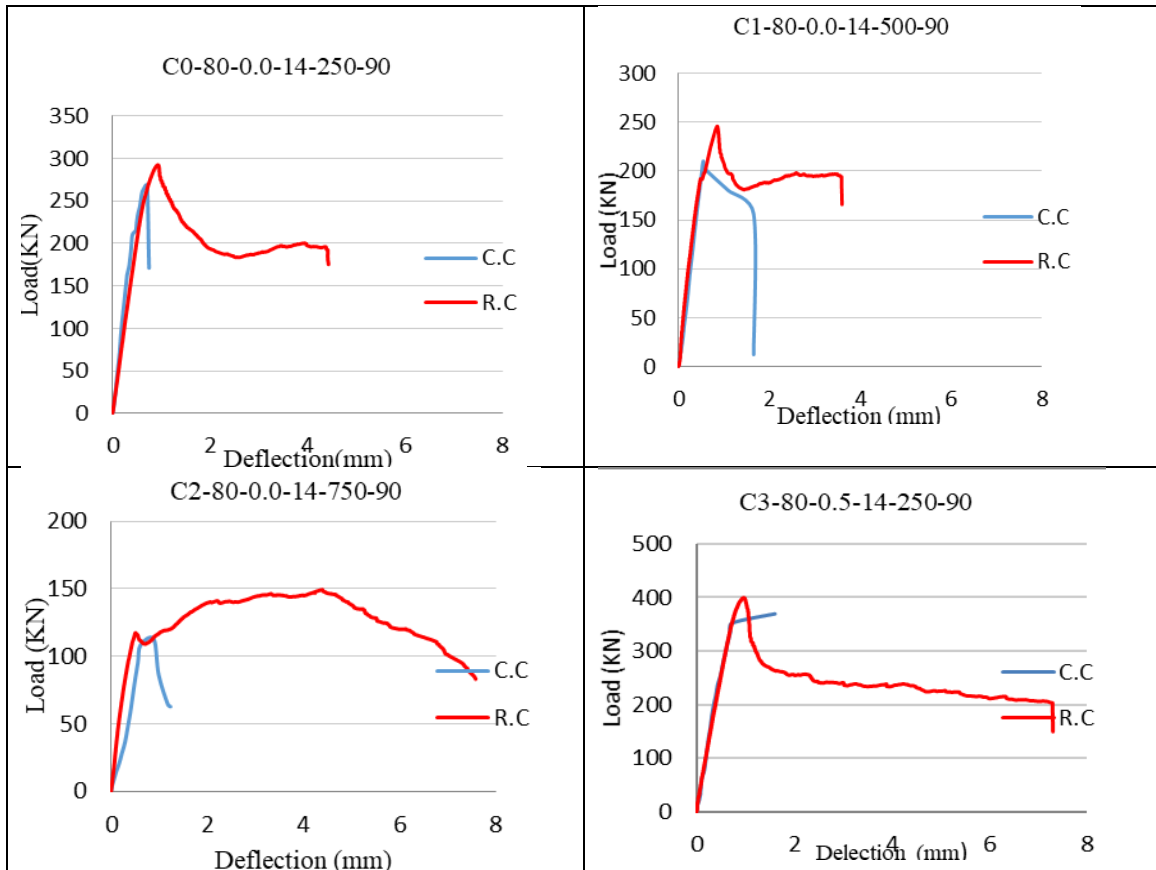

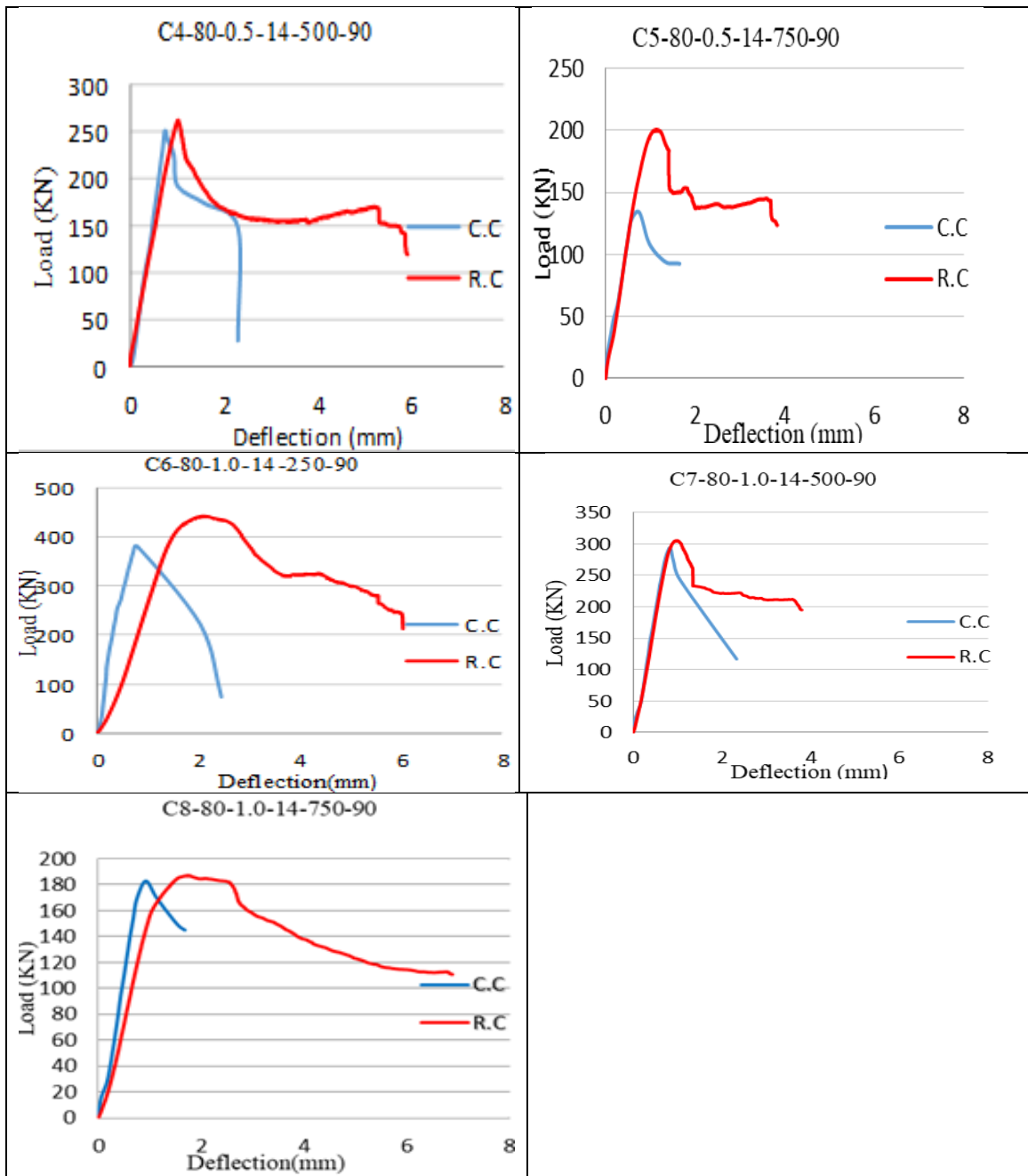

Figure 6 Load-deflection curves of rehabilitated corbels

CONCLUSION

In this study, a new technique was investigated for the rehabilitation of damaged reinforced concrete corbels reinforced with or without steel fiber for the first time in literature. Damaged corbels due to exposure to high temperature and overloading were repaired by crack repair epoxy and strengthened by basalt fiber fabric (BFF). The effectiveness of the method was researched by vertical loading tests. In general, it is concluded that use of crack repair epoxy and basalt fiber fabric for the rehabilitation of damaged reinforced or steel fiber reinforced concrete corbels increases the original load capacity and ductility considerably.

The following conclusion can be estimated after the experimental study:

In general, rehabilitation with basalt fiber fabric increases the load capacity of corbels and it ensures restoring original load capacity of the corbels. Energy absorption capability and ductility for all the BFF-strengthened corbels increases. The existence of steel fiber plays an important role in the rehabilitation of high strength concrete corbels about ductility. It increases the effectiveness of the rehabilitation due to partial restoring of bridging effect of steel fibers. This situation leads to an economical solution for rehabilitation of corbels by using BFF. As a result of the study, it is also concluded that almost the same stiffness value of corbels before rehabilitation is achieved after rehabilitation of them with basalt fiber fabric. Moreover, the existence of a high number of micro and macro cracks in damaged corbels decreases the effectiveness of the proposed rehabilitation technique, especially an increase in the load capacity of them.

RECOMMENDATIONS

As compared to the alternatives, basalt fiber fabric is one of the most economical and effective technique for the rehabilitation of reinforced concrete high strength corbels. The authors recommend that either use of bi-directional basalt fiber fabric or use of uni-directional fabric in two directions (horizontal and vertical) makes the proposed rehabilitation technique much more effective.

This study can be extended by the investigation of more economical solutions about the rehabilitation of damaged corbels. For instance, basalt fiber fabric can be cut into thin strips and these strips can be glued to the critical regions of the damaged corbels in which higher stresses and wider cracks were expected due to vertical loading.

REFERENCES

- Ahmad, S., Elahi, A., Kundi, S., & Haq, W. (2013). Investigation of shear behavior of Corbel beams strengthened with CFRP. *Life Science Journal*, 10(12s). article.
- Corry, R. W., & Dolan, C. W. (2001). Strengthening and repair of a column bracket using a carbon fiber reinforced polymer (CFRP) fabric. *PCI Journal*, 46(1).

- Czigány, T., Vad, J., & Pölöskei, K. (2005). Basalt fiber as a reinforcement of polymer composites. *Periodica Polytechnica. Engineering. Mechanical Engineering*, 49(1), 3.
- Elgwady, M. A., Rabié, M., & Mostafa, M. T. (2005). Strengthening of corbels using CFRP an experimental program. Cairo University, Giza, Egypt.
- Erfan, A. M., Abdel-Rahman, G. T., Nassif, M. K., & Hammad, Y. H. (2010). Behavior of reinforced concrete corbels strengthened with CFRP fabrics. Benha University. article.
- Foster, S. J., & Malik, A. R. (2002). Evaluation of efficiency factor models used in strut-and-tie modeling of nonflexural members. *Journal of Structural Engineering*, 128(5), 569–577.
- Foster, S. J., Powell, R. E., & Selim, H. S. (1996). Performance of high-strength concrete corbels. *ACI Structural Journal*, 93(5), 555–563.
- Hwang, S.-J., & Lee, H.-J. (2002). Strength prediction for discontinuity regions by softened strut-and-tie model. *Journal of Structural Engineering*, 128(12), 1519–1526.
- Ivanova, I., & Assih, J. (2015). EXPERIMENTAL STUDY OF LOCAL BEHAVIOR OF STRENGTHENED REINFORCED CONCRETE SHORT CORBEL BY BONDING CARBON FIBER FABRICS. article.
- Ivanova, I., & Assih, J. (2015). Static and dynamic experimental study of strengthened inforced short concrete corbel by using carbon fabrics, crack path in shear zone. *Frattura Ed Integrita Strutturale*, (34). article.
- Ivanova, I., Assih, J., & Dontchev, D. (2016). Mechanical Pathologies of Reinforced and Damaged Concrete Corbels by Gluing Composite Carbon Fabrics Under Static and Dynamic Tests. In *Sustainable Construction* (pp. 185–211). incollection, Springer.
- Kumar, R. A., Selvamony, C., Seenii, A., & Sethuraman, T. R. (2015). Retrofitting Of RCC Piles By Using Basalt Fiber Reinforced Polymer (BFRP) Composite, Part: 1 Review Papers On RCC Structures And Piles Retrofitting Works. *International Journal of Technology Enhancements and Emerging Engineering Research*, 4(1), 103–115. article.
- Liu, Q., Shaw, M. T., Parnas, R. S., & McDonnell, A.-M. (2006). Investigation of basalt fiber composite mechanical properties for applications in transportation. *Polymer Composites*, 27(1), 41–48.
- Russo, G., Venir, R., Pauletta, M., & Somma, G. (2006). Reinforced concrete corbels-shear strength model and design formula. *ACI Structural Journal*, 103(1), 3.
- Toumi, B., Resheidat, M., Guemmadi, Z., & Chabil, H. (2009). Coupled Effect of High Temperature and Heating Time on the Residual Strength of Normal and High-Strength Concretes. *Jordan Journal of Civil Engineering*, 3(4), 322–330.
- Yong, Y.-K., & Balaguru, P. (1994). Behavior of reinforced high-strength-concrete corbels. *Journal of Structural Engineering*, 120(4), 1182–1201.