

# Flexural Vibrations of a Rotating Beam Subjected to Different Base Excitations

Şefaatin YÜKSEL <sup>1\*</sup>, Taylan Mete AKSOY <sup>2</sup>

<sup>1</sup> Gazi University, Faculty of Engineering & Architecture, Department of Mechanical Engineering, Ankara, Turkey

<sup>2</sup> 901<sup>st</sup> Army Aviation Depot, Ankara, Turkey

Received: 20.03.2008 Revised: 05.01.2009 Accepted: 13.01.2009

---

## ABSTRACT

In this study, bending vibrations of a radially rotating beam with end mass subjected to different base excitations are investigated. Upon considering the assumption of an Euler-Bernoulli beam in addition to the effects of rotary inertia, end-mass, and axial force in association with axial foreshortening, the equations of motion are derived by using the Lagrangian's approach. Due to difficulties in finding an analytical solution, the assumed modes method is utilized to obtain approximate solutions. Numerical solutions of the differential equations are presented for different base excitations.

**Key Words:** Rotating Beam, Base Excitation

---

## 1. INTRODUCTION

Rotating beams are very common components of rotating machinery such as rotor blades, propellers, turbines, robot arms and numerous others. Therefore, rotating beams have received considerable attention in the literature. Considering a rotor spinning about a fixed axis at a constant angular velocity, Wright et al. [1] utilized the Hamilton's principle in order to write the equation of motion and used the Frobenius method to solve it for exact frequencies and mode shapes. They tabulated the results for a variety of situations including uniform and tapered beams, with root offset and tip mass, and different boundary conditions. Kojima [2] investigated the transient vibrations of a beam/mass system fixed to a rotating body that has a velocity profile of trapezoidal shape. Kane and Ryan [3] presented a theory for dealing with small vibrations of a general beam attached to a base that is undergoing an arbitrarily prescribed motion. Scott and Ulsoy [4] investigated flexural motion of radially rotating beam attached to a rigid body. They derived fully coupled non-linear equations of motion by using the extended Hamilton's principle and investigated the effect of the coupling terms upon the vibration waveforms by using both linearized analysis and numerical solutions of the differential equations. The vibrational behaviour of a rotating beam oriented perpendicularly to the spin axis was investigated by Bauer and Eidel [5] for all possible

combinations of free, clamped, hinged and guided boundaries. Low [6] developed a model to analyze the Euler-Bernoulli beam having a slender payload at the free end and attached to a rotating hub at the other end. The derived system equations with the complete boundary conditions were solved by using the secant method. Gürgöze [7] studied the dynamic behaviour of an elastic beam attached to a rigid ring rotating with constant angular velocity. The aim of the study was to provide simple formulas which were obtained via perturbation approach and can be useful for design engineers. Kuo et al. [8] investigated the influence of taper ratio, elastic root restraints, tip mass, setting angle and rotating speed on the pure bending vibration of rotating non-uniform beams. They neglected the Coriolis forces induced from rotation and assumed the beams to be symmetric such that the mass axis, centroidal axis and elastic axis are coincident. Boutaghou et al. [9] proposed an approach dealing with an arbitrary representation of the kinematics of deformation which may include shear, initial curvature, initial twist, arbitrary cross sectional effects, dynamic stiffening effects, rotary inertia, von Karman geometric constraints and kinematic constraints. They carried out an application example for the Euler-Bernoulli beam kinematics. Subrahmanyam and Kaza [10] studied the individual and collective effects of pretwist, precone, setting angle, Coriolis forces and blade thickness ratio on the vibration frequencies and buckling boundaries of

---

\*Corresponding author, e-mail: s.yuksel@gazi.edu.tr

rotating beams. They employed the finite difference and Ritz types of solution procedure for the solution of the vibration problem. Yoo and Shin [11] derived three sets of linear equations of motion for the modal analysis of the rotating cantilever beams by utilizing a new dynamic modeling method. Al-Bedoor [12] presented a dynamic model for a rotating flexible blade attached to a rigid disk by a shaft which is flexible in torsion. The author utilized the finite element method in conjunction with the Euler-Bernoulli beam theory including the axial shortening and gravitational effects. Lee [13] formulated the equations of motion in matrix form for a pre-twisted cantilever beam with a spinning base subject to axial acceleration excitations by using Hamilton's principle and the assumed mode method. Tan et al. [14] derived the equations of motion of a rotating cantilever beam subjected to base excitation by using the Euler beam theory and the assumed mode method. They indicated that increasing the hub radius to beam length ratio as well as angular velocity tends to have a stabilizing effect on the system whereas increasing the base excitation force results in a undesirable amplitude.

In this paper, a more general problem of a rotating cantilever beam subjected to different base excitations

is discussed by including most of the effects. These are rotary inertia, end-mass, and axial force in association with axial foreshortening. The base excitations are taken into account by considering a rotating beam connected to a whirling shaft. The equations of motion and the associated boundary conditions are derived by utilizing the extended Hamilton's principle. Due to difficulties in finding a direct analytical solution, the assumed modes method is developed in order to obtain an approximate solution. In the rest of the paper, some simulation results for different base excitations are presented.

## 2. EQUATIONS OF MOTION

The dynamic system to be considered is shown in Figure 1. It consists of a whirling shaft connected to an elastic beam in flexure with a concentrated end-mass  $M$ . The elements of elastic beam are constrained to move on the  $x$ - $y$  plane and the gravity is in the direction of axis  $X$ . The shaft is rotating with the constant angular velocity  $\omega$  and a whirling velocity  $\dot{\theta}$ . The center of the shaft displaces with  $r(t)$  and the radius of the shaft is assumed to be negligible compared with the beam length  $L$ .

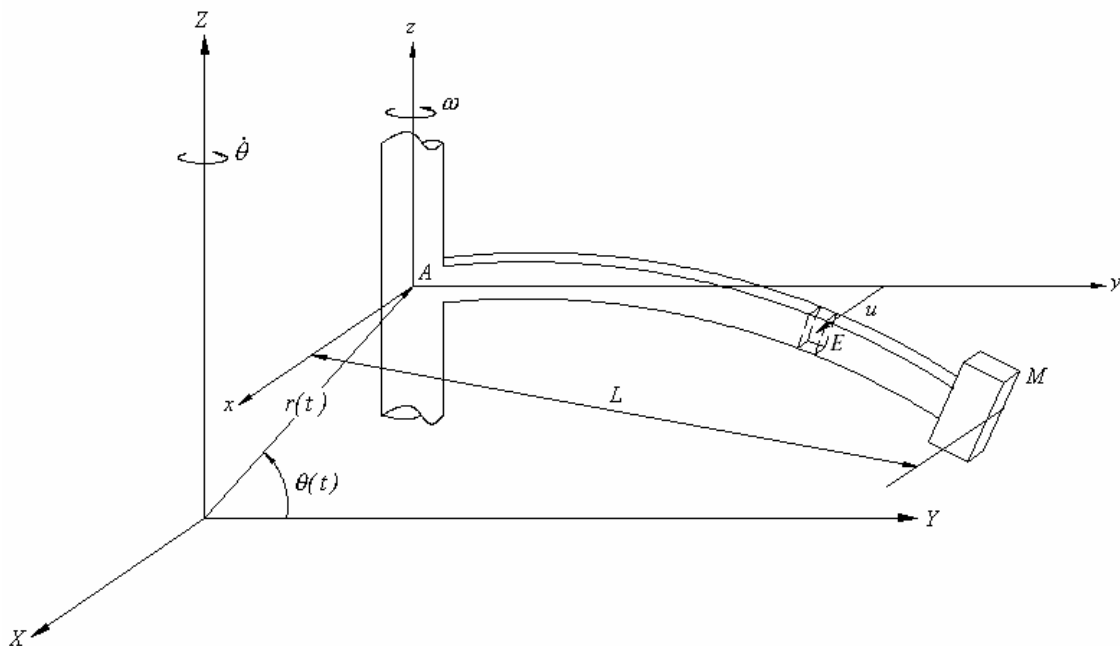

Figure 1. A flexible beam on a rotating shaft subjected to base excitation.

As shown in Figure 1, there are two co-ordinate systems to be used in the mathematical analysis of the dynamic system. One of them is an inertial co-

ordinate system denoted by  $XYZ$ . The second is the moving co-ordinate system denoted by  $xyz$  attached at the center of the rotating shaft.

The equations of motion is derived by using the extended Hamilton's principle

$$\int_{t_1}^{t_2} [\delta(T - V) + \delta'A] dt = 0 \quad (1)$$

where T denotes, as usual, the kinetic energy, V denotes the potential energy and  $\delta'A$  represents the virtual work done by nonconservative forces acting on the system. Here, the virtual work is zero ( $\delta'A = 0$ ) since no external forcing is included.

The kinetic energy consists of two parts which are due to translation and rotation of each element of the beam. The rotational kinetic energy is

$$T_1 = \rho \frac{I}{2} \int_0^L (\omega - \dot{u}')^2 dy \quad (2)$$

where  $\rho$  shows the mass density, I is the mass moment of inertia for the uniform beam cross-section,  $u(y,t)$  represents the bending displacement corresponding to the section of the beam as shown in Figure 1, and  $\omega$  denotes the rotational speed about the z axis. Prime and dot in the above equation refer to partial derivatives with respect to the position co-ordinate y and time t, respectively. Also, the end mass is a concentrated mass in which the rotary inertia terms is negligible, otherwise it should be included in the equation.

In a similar manner, by utilizing the absolute translational velocity vector  $V$  with respect to the xyz co-ordinate system of a typical element on the elastic beam

$$V = \begin{Bmatrix} \dot{r}_x \cos \omega t + \dot{r}_y \sin \omega t - \omega y + \dot{u} \\ -\dot{r}_x \sin \omega t + \dot{r}_y \cos \omega t + \omega u \\ 0 \end{Bmatrix} \quad (3)$$

the translational kinetic energy can be obtained as

$$T_2 = \frac{1}{2} \int_0^L [\rho A + M \delta(y-L)] \{ \dot{r}_x^2 + \dot{r}_y^2 + \omega^2 y^2 + \omega^2 u^2 + \dot{u}^2 - 2\omega y \dot{u} + 2\dot{u}(\dot{u} - \omega y)(\dot{r}_x \cos \omega t + \dot{r}_y \sin \omega t) - 2\omega u(\dot{r}_x \sin \omega t - \dot{r}_y \cos \omega t) \} dy \quad (4)$$

where A is the cross-sectional area of the beam, and M is the concentrated end mass. In equation (4), a spatial Dirac delta function is defined as

$$\delta(y-L) = 0 \quad y \neq L$$

$$\int_0^L \delta(y-L) dy = 1 \quad (5)$$

On the other hand, the potential energy consists of three parts. The strain energy due to the bending, the potential energy associated with the axial force arising due to inertial forces in connection with the so-called axial foreshortening, and the part due to the gravitational effect. The potential energy due to the bending is

$$V_1 = \frac{1}{2} \int_0^L (Elu''^2) dy \quad (6)$$

Here,  $El$  denotes the flexural rigidity.

Using equation (8), the axial force can be expressed as

$$P(y,t) = -M[-\ddot{r}_x \sin \omega t + \ddot{r}_y \cos \omega t - \omega^2 L] + \rho A [(-\ddot{r}_x \sin \omega t + \ddot{r}_y \cos \omega t)(y-L) - \frac{\omega^2}{2}(y^2 - L^2)] \quad (9)$$

On the other hand, the gravitational potential energy can be expressed as

Furthermore, the potential energy arising from the axial force associated with the foreshortening can be expressed as

$$V_2 = \frac{1}{2} \int_0^L P(y,t) u'^2 dy \quad (7)$$

where  $P(y,t)$  is the axial force. Differentiating the second element of the velocity vector in equation (3), the absolute acceleration of a typical element at point E on the elastic beam with respect to the axis  $y_A$  is

$$\alpha_E = -\ddot{r}_x \sin \omega t + \ddot{r}_y \cos \omega t - \omega^2 y \quad (8)$$

$$V_3 = \int_0^L g[\rho A + M\delta(y-L)]r_E dy \quad (10)$$

where  $r_E$  is the position of the element at point  $E$  on the elastic beam with respect to the axis  $X$

$$r_E = r_x + u \cos \omega t - y \sin \omega t \quad (11)$$

and  $g$  is the gravitational acceleration.

Consequently, summing the kinetic and potential energy terms as

$$T = T_1 + T_2 \quad , \quad V = V_1 + V_2 + V_3 \quad (12)$$

and finally making use of Hamilton's principle given in equation (1), one can obtain after lengthy calculations the equation of motion for the rotating beam as

$$\rho I \ddot{u}'' + [\rho A + M\delta(y-L)] \left[ -\ddot{u}'' + \dot{\omega} y + \omega^2 u - \ddot{r}_x \cos \omega t - \ddot{r}_y \sin \omega t \right] + \left. \begin{array}{l} \left[ \frac{-M}{\rho A} (-\ddot{r}_x \sin \omega t + \ddot{r}_y \cos \omega t - \omega^2 L) + (-\ddot{r}_x \sin \omega t + \ddot{r}_y \cos \omega t)(y-L) \right] \\ \left[ -\frac{\omega^2}{2}(y^2 - L^2) \right] \\ \left[ (-\ddot{r}_x \sin \omega t + \ddot{r}_y \cos \omega t - \omega^2 y)u' \right] \end{array} \right\} u'' + \left. \begin{array}{l} \\ \\ \\ \end{array} \right] - g[\rho A + M\delta(y-L)] \cos \omega t - EI u^{IV} = 0 \quad (13)$$

and the associated boundary conditions are

$$u(0,t) = 0 \quad (14)$$

$$u'(0,t) = 0 \quad (15)$$

$$u''(L,t) = 0 \quad (16)$$

$$\left[ I(\dot{\omega} - \ddot{u}') + \frac{M}{\rho} (-\ddot{r}_x \sin \omega t + \ddot{r}_y \cos \omega t - \omega^2 L)u' + \frac{EI}{\rho} u''' \right]_{y=L} = 0 \quad (17)$$

Due to difficulties in finding an analytical solution, using the assumed mode method the quantities  $u(y,t)$  can be expressed as

$$u(y,t) = \sum_{j=1}^{\infty} q_j(t) e_j(y) \quad (18)$$

where  $e_j$  are the admissible functions that satisfy the geometric boundary conditions at the clamped end of the beam and  $q_j$  are the time dependent generalized co-ordinates to be determined. Here, the eigenfunctions of a clamped-free beam are chosen as the admissible functions

$$e_j(y) = \cosh(\hat{\lambda}_j \frac{y}{L}) - \cos(\hat{\lambda}_j \frac{y}{L}) - \eta_j [\sinh(\hat{\lambda}_j \frac{y}{L}) - \sin(\hat{\lambda}_j \frac{y}{L})] \tag{19}$$

in this expression

$$\eta_j = \frac{\cosh \hat{\lambda}_j + \cos \hat{\lambda}_j}{\sinh \hat{\lambda}_j + \sin \hat{\lambda}_j} \tag{20}$$

and  $\hat{\lambda}_j$  are the weighted frequencies determined from the solution of the characteristic equation

$$\cosh \hat{\lambda}_j \cos \hat{\lambda}_j = -1 \tag{21}$$

Now, substituting the infinite series given by (18) into the kinetic and potential energy terms given by (2), (4) and (6), (7)-(12), then using them in the Lagrange's equations according to the assumed mode method, the equations of motion may be obtained in the discretized form as follows

$$\left. \begin{aligned} & \left[ \int_0^L \left( 1 + \frac{M}{\rho A} \delta(y-L) \right) e_j e_k + \frac{I}{A} e'_j e'_k \right] dy \ddot{q}_j + \\ & \left[ \int_0^L \left( 2\omega(y-L) - \frac{2M}{\rho A} \omega \right) e'_j e'_k e_j \right] dy q_j \dot{q}_j + \\ & \sum_{j=1}^{\infty} \left[ \int_0^L \left( -\omega^2 \left( 1 + \frac{M}{\rho A} \delta(y-L) \right) e_j e_k + \frac{EI}{\rho A} e''_j e''_k + ((-\ddot{r}_x \sin \omega t + \ddot{r}_y \cos \omega t)(y-L)) \right) e_j e_k \right. \\ & \left. - \frac{\omega^2}{2} (y^2 - L^2) - \frac{M}{\rho A} (-\ddot{r}_x \sin \omega t + \ddot{r}_y \cos \omega t - \omega^2 L) \right) e'_j e'_k \right] dy q_j = 0 ; k = 1, \dots, \infty \\ & \left[ \int_0^L \left( -\ddot{r}_x \cos \omega t - \ddot{r}_y \sin \omega t + \dot{\omega} y \right) \left( 1 + \frac{M}{\rho A} \delta(y-L) \right) e_k + \frac{I}{A} \dot{\omega} e'_k - \right. \\ & \left. \left( g \left( 1 + \frac{M}{\rho A} \delta(y-L) \right) \cos \omega t \right) e_k \right] dy \end{aligned} \right\} \tag{22}$$

The equation (22) completely governs the vibrational behaviour of the rotating beam with an end-mass and will be used for the simulation studies. Since the boundary conditions of the system have also been taken into account, there is no remaining condition term to be satisfied.

### 3. NUMERICAL RESULTS

The approximate equations of motion of the dynamic system can be solved by using one of the common Runge-Kutta computational algorithms. Taking finite series instead of the infinite ones given by (18), the simulation studies are performed for the typical cases. Due to its importance, the tip deflections of the beam are calculated in the simulation studies by taking 2 terms. In the numerical examples, it is assumed that the beam material is aluminum having a density of  $\rho = 2700 \text{ kg} / \text{m}^3$  and a modulus of elasticity of  $E = 7 \times 10^{10} \text{ N} / \text{m}^2$ . For the beam geometry, the following values are used; the cross-sectional area

$A = 0.0001 \text{ m}^2$ , the moment of inertia  $I = 1.2 \times 10^{-10} \text{ m}^4$ , and the length of the beam  $L=1 \text{ m}$ , which makes the beam very slender. As the end-mass,  $M=0.1 \text{ kg}$  is used. In the simulation studies different base excitations are used in order to investigate base excitations effects on the vibration.

As an initial simulation study, Figure 2 represents the tip deflections of the rotating beam without any base excitation. The hub is rotating with a constant angular velocity.

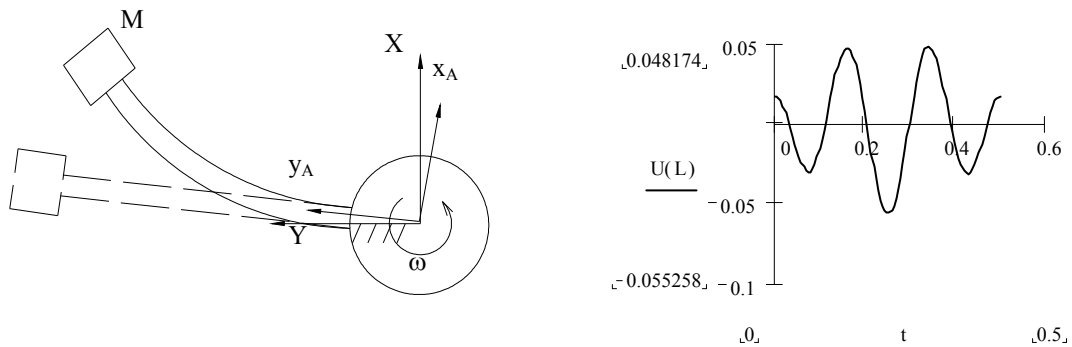

Figure 2. Tip deflections for  $L=1\text{ m}$ ,  $r(t)=0\text{ m}$ ,  $\omega=1500\text{ rpm}$ ,  $M=0.1\text{ kg}$ ,  $T=0.5\text{ s}$ .

Figure 3 illustrates the tip deflections for the case when the rotating hub is excited along only one axis. This case is similar to the study of Tan et al [14]. The deflections in Figure 3 are larger than those of Figure 2,

showing that the given base excitation to the hub increases the tip deflections of the beam.

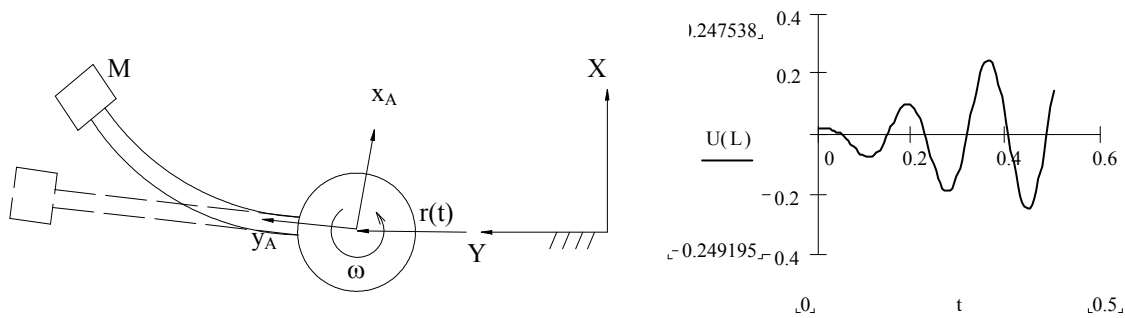

Figure 3. Tip deflections for  $L=1\text{ m}$ ,  $r_x=0$ ,  $r_y = 0.1\sin(\dot{\theta}t)\text{ m}$ ,  $\dot{\theta} = \omega/2 = 750\text{ rpm}$ ,  $\omega = 1500\text{ rpm}$ ,  $M=0.1\text{ kg}$ ,  $T=0.5\text{ s}$ .

On the other hand, the rotation of the plane containing the bent shaft about the bearing axis is known as whirling, which was investigated for a rigid shaft carrying a disk by Meirovitch [15]. Upon considering the beam connected to a whirling hub, Figure 4 shows

the tip deflections. In this case, the hub rotates and whirls with the same angular velocity, known as synchronous whirl there the center of the hub describes a circle. As seen from Figure 2 and Figure 4, this type of excitation results in the larger tip deflections.

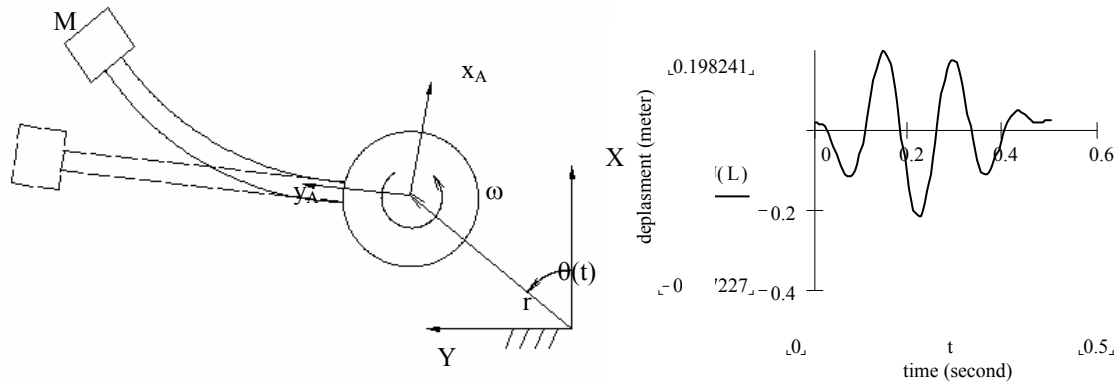

Figure 4. Tip deflections for  $L=1\text{ m}$ ,  $r_x = 0.1 \cos(\dot{\theta} t)\text{ m}$ ,  $r_y = 0.1 \sin(\dot{\theta} t)\text{ m}$ ,  $\dot{\theta} = \omega = 1500\text{ rpm}$ ,  $M=0.1\text{ kg}$ ,  $T=0.5\text{ s}$ .

Furthermore, Figure 5 illustrates the tip deflections of the beam as the center of the hub describes an ellipse. In case shown in (a), the rotation and whirling are the same sense, but in case shown (b), the center of the hub whirls in the opposite sense of the rotation. In these two cases, the vibrations of the tip point of the beam have similar mode shapes but slightly different frequencies and magnitudes.

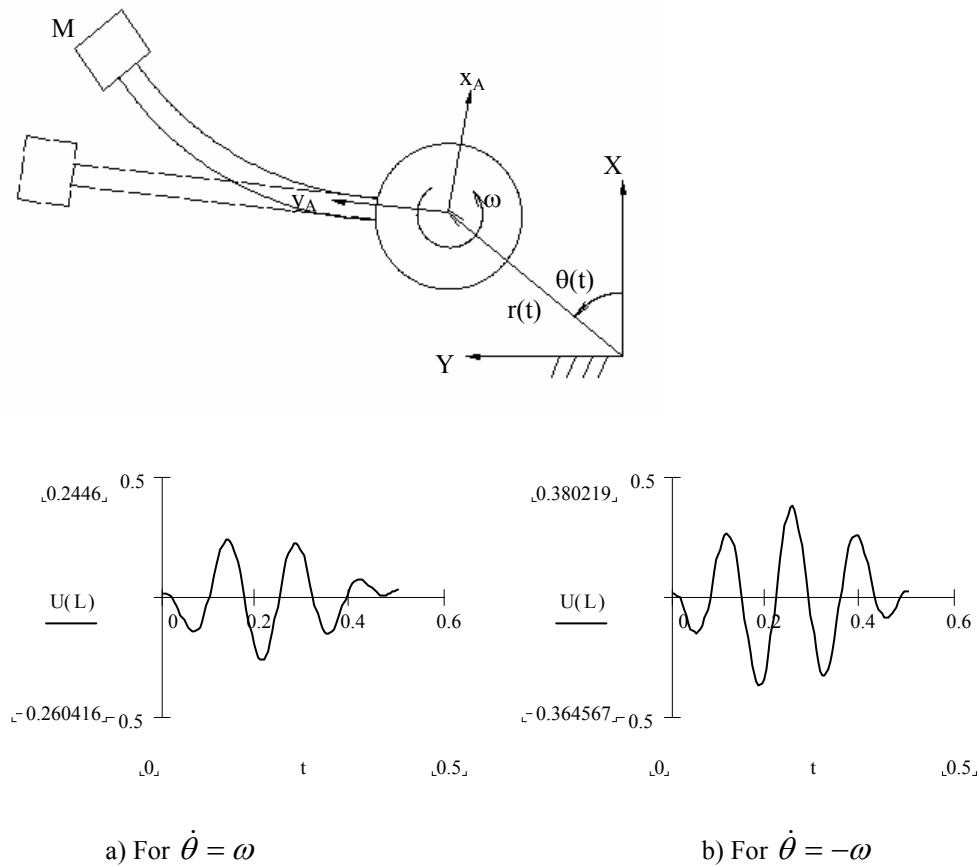

Figure 5. Tip deflections for  $L=1\text{ m}$ ,  $r_x = 0.15 \cos(\dot{\theta} t)\text{ m}$ ,  $r_y = 0.1 \sin(\dot{\theta} t)\text{ m}$ ,  $\dot{\theta} = \omega = \pm 1500\text{ rpm}$ ,  $M=0.1\text{ kg}$ ,  $T=0.5\text{ s}$ .

#### 4. CONCLUSIONS

The flexural vibrations of a flexible linear beam with different base excitations are investigated. The effects of the rotational inertia, the axial force associated with the axial shortening and the end-mass are considered together with the Euler-Bernoulli beam assumption. The equations of motion are derived by using the Lagrangian's approach. Since they form a very complex boundary value problem for which an exact solution is not possible, the assumed modes method is used to obtain an approximate solution. The corresponding numerical results are presented in the form of plots.

#### ACKNOWLEDGMENTS

The authors would like to thank Dr. T. Karaçay for his very helpful comments, suggestions and technical help. The responsibility for the results presented and the opinions expressed belongs completely to the authors and not to 901<sup>st</sup> Army Aviation Depot.

#### REFERENCES

- [1] Wright, A.D., Smith, C.E., Thresher, R.W., Wang, J.L.C., "Vibration modes of centrifugally stiffened beams", *Journal of Applied Mechanics*, 49: 197-202 (1982).
- [2] Kojima, H., "Transient vibrations of a beam/mass system fixed to rotating body", *Journal of Sound and Vibration*, 107(1): 149-154 (1986).
- [3] Kane, T.R., Ryan, R.R., "Dynamics of a cantilever beam attached to a moving base", *Journal of Guidance*, 10(2): 139-151 (1987).
- [4] Yiğit, A., Scott, R.A., Ulsoy, A.G., "Flexural motion of a radially rotating beam attached to a rigid body", *Journal of Sound and Vibration*, 121: 201-210 (1988).
- [5] Bauer, H.F., Eidel, W., "Vibration of a rotating uniform beam, part II: Orientation perpendicular to the axis of rotation", *Journal of Sound and Vibration*, 122: 357-375 (1988).
- [6] Low, K.H., "Eigen-Analysis of a tip load beam attached to a rotating base", *The American Society of Mechanical Engineers*, 89: WA/DSC-3 (1989).
- [7] Gürgöze, M., "On the dynamical behavior of a rotating beam", *Journal of Sound and Vibration*, 143: 356-363 (1990).
- [8] Kuo, Y.H., Wu, T.H., Lee, S.Y., "Bending vibrations of a rotating non-uniform beam with tip mass and an elastic restrained root", *Computers & Structures*, 42: 229-236 (1992).
- [9] Boutaghou, Z.E., Erdman, A.G., Stolarski, H.K., "Dynamics of flexible beams and plates in large overall motions", *Journal of Applied Mechanics*, 59: 991-999 (1992).
- [10] Subrahmanyam, K.B., Kaza, K.R.V., "Vibration and buckling of rotating, pretwisted, precone beams including Coriolis effects", *Journal of Vibration, Acoustics, Stress and Reliability in Design*, 108: 140-149 (1995).
- [11] Yoo, H.H., Shin, S.H., "Vibration analysis of rotating cantilever beams", *Journal of Sound and Vibration*, 212: 807-828 (1998).
- [12] Al-Bedoor, B.O., "Dynamic model of coupled shaft torsional and blade bending deformations in rotors", *Comput. Methods Appl. Mech. Engrg.*, 169: 177-190 (1999).
- [13] Lee, H.P., "Effects of axial base excitations on the dynamic stability of spinning pre-twisted cantilever beam", *Journal of Sound and Vibration*, 185(2): 265-278 (1995).
- [14] Tan, T.H., Lee, H.P., Leng, G.S.B., "Dynamic stability of radially rotating beam subjected to base excitation", *Comput. Methods Appl. Mech. Engrg.*, 146: 265-279 (1997).
- [15] Meirovitch, L., "Elements of Vibration Analysis" 2nd ed., *McGraw-Hill*, 58-63 (1986).