

Lateral Pressures on Rigid Retaining Walls: A Neural Network Approach

Ersan YILDIZ^{1*}, Mehmet H. OZYAZICIOGLU², M. Yener OZKAN³

¹Design Engineer, Temelsu Int. Eng. Serv. Inc., Ankara, Turkey
²Atatürk University, Department of Civil Engineering, Erzurum, Turkey,
³METU, Department of Civil Engineering, Ankara, Turkey

Received: 11.05.2009 Revised: 28.12.2009 Accepted: 11.01.2010

ABSTRACT

An artificial neural network solution (in closed form expression) is established for the total lateral thrust and its point of application on rigid retaining walls due to finite surface strip loads. The model accounts for soil nonlinearity and dilatancy. Data necessary for the model is produced through finite element analyses. The solution relates the total lateral thrust and its point of application to six parameters, including the strength parameters of the soil, wall height and the position as well as the extent of the surface load. The effects of each input parameter on the response are summarized and the results are compared with the linear elastic solution.

Key Words: Lateral Earth Pressure, Strip Load, Artificial Neural Networks, Hardening Soil Model.

1. INTRODUCTION

In many applications of soil engineering, lateral pressures acting on non-yielding retaining walls due to surface strip loads are required. Retaining structures supporting continuous wall footings, highways, railroads and crane loads are typical examples of this loading condition. Linear elastic solution derived from Boussinesq's equations [1, 2] is frequently used for the determination of the lateral thrust in such cases. However, soil behaviour deviates considerably from that predicted by the linear theory of elasticity and the consequences of nonlinear and plastic deformation effects on stress distribution within or on the boundaries of soil masses is still of concern to civil engineers. A solution in closed form, accounting for nonlinear soil behaviour, would be a useful tool in geotechnical engineering practice.

The objective of this study is to obtain a closed form expression relating the total lateral thrust due to surface strip loading and its point of application on a rigid wall to six parameters; namely, cohesion and angle of internal friction of soil, magnitude and width of the load, height of the wall and distance of the strip load from the wall.

The solution is proposed to be obtained by using artificial neural networks based on the data produced by nonlinear finite element analyses. MATLAB [3] together with the Neural Network Toolbox [4] is used to establish and train the neural network in this study.

2. ARTIFICIAL NEURAL NETWORKS (ANN)

Artificial neural networks are computational devices inspired by the biological system of the brain. A neural network is a parallel processing system composed of many interconnected processors (called neurons). A neuron in turn is a simple computational device that has a single or multiple inputs and a single output. Each neuron is connected to the neighboring neurons by weights on which the function of the network mainly depends.

Figure 1 shows a single-input neuron. The input p is multiplied by the weight " w " and a bias " b " is added to form the net input " n " which is used by the transfer function to compute the output " a " of the neuron.

*Corresponding author, e-mail: civil182@yahoo.com

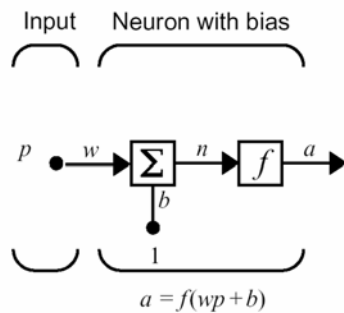

Figure 1. Neuron with single input (from MATLAB® User's Guide).

A layer of network is formed by multiple neurons combined in parallel. A single layer network is insufficient for solving most of the problems and generally two or more layers participate in a typical neural network. The layer whose output is the output of the whole network is called the output layer and the other layers are named as hidden layers.

ANN's are trained to perform a particular function by modifying the weights according to a learning rule that defines how the network is modified in response to experience. In supervised learning techniques, the learning rule is provided with an input-output database and the weights are so optimized as to minimize the error between the target and output values.

A back-propagation type neural network, which is widely used in function approximation and pattern mapping, is adopted in this study. Back-propagation is a training algorithm that uses the generalized delta rule for multiple layer networks with non-linear differentiable transfer functions [5, 6, 7, 8, 9].

Backpropagation learning rules are based on the simple concept: the error between the actual output and the desired output is lessened by modifying the weights and as a result future responses are more likely to be correct. When the network is given an input, the output units are obtained by simulation of the network. The output layers then provide the network's response. When the network corrects its internal parameters, the correction mechanism starts with the output layers and back-propagates backward through each internal (hidden) layer. Hence the term backpropagation is used for this kind of networks [7].

2. LATERAL EARTH PRESSURE DUE TO SURFACE STRIP LOAD: CONVENTIONAL METHODS

There are several solutions in closed form for the problem of lateral earth pressure due to surface strip loads published in the literature. First, we have the famous elastic solution due to Boussinesq [10, 2]. Second, there is the limit equilibrium solution [11] and next there are some proposed approximate solutions, namely the Beton Kalender [12] and 45-degree distribution [12, 13] approaches. An extensive survey reveals no solution developed by using theory of plasticity or nonlinear material models.

The limit equilibrium and approximate solutions assume an active state. Considerable wall deformations or movements have to occur in order for an active state to develop. On the other hand, many retaining structures like anchored walls supporting excavation cuts next to existing structures, has to be designed for K_0 conditions in order to reduce foundation movements. Hence the limit equilibrium and approximate solutions are not appropriate for non yielding walls under K_0 loading conditions. Therefore, the geotechnical engineer is left with the linear elastic solution as the only appropriate solution for rigid wall case.

The lateral earth pressure caused by a strip surface load [2] can be obtained by integrating Boussinesq solution:

$$\sigma_h = \frac{2q}{\pi} [\beta - \sin(\beta) \cdot \cos(2\alpha)] \quad (7)$$

3. THE PROPOSED METHOD

We claim that a closed form expression for total lateral earth pressure and its point of application can be derived from an ANN model, provided adequate data to train the network is available. The required data is produced by nonlinear finite element analysis of a rigid retaining wall model supporting a cohesive back-fill subject to a surface strip load of finite extent. This data is then used to train the ANN model which yields the closed form solution.

The following assumptions are made:

- Plane strain condition prevails in the soil mass
- The ground surface is horizontal
- The wall is vertical
- The wall is non-displacing and rigid
- The backfill rests on a rigid subgrade
- The wall is perfectly smooth (frictionless)
- The load is perfectly flexible

Figure 3 shows a sketch of the problem geometry. In the figure; h is the wall height, a is the distance of the strip load to the wall, w is the width of the strip load, q is the magnitude of the load, σ_h is the lateral earth pressure due to strip load, p is the total lateral thrust on the wall due only to strip load and d is the distance to the point of application of p as measured from the ground surface.

The hardening soil model [14] is used to represent the backfill. Being basically a hyperbolic material model [15, 16] with plastic yielding, the hardening soil model uses the isotropic hardening rule in the calculation of both shear and volumetric strains. Shear hardening is used to model plastic strains due to primary deviatoric loading and compression hardening is used to model plastic strains due to primary compression under oedometer and isotropic loading conditions.

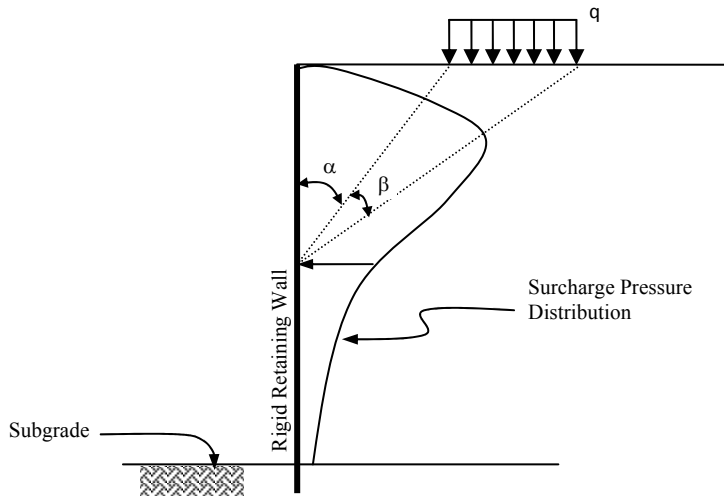

Figure 2. Linear elastic solution for lateral pressure due to surface strip load.

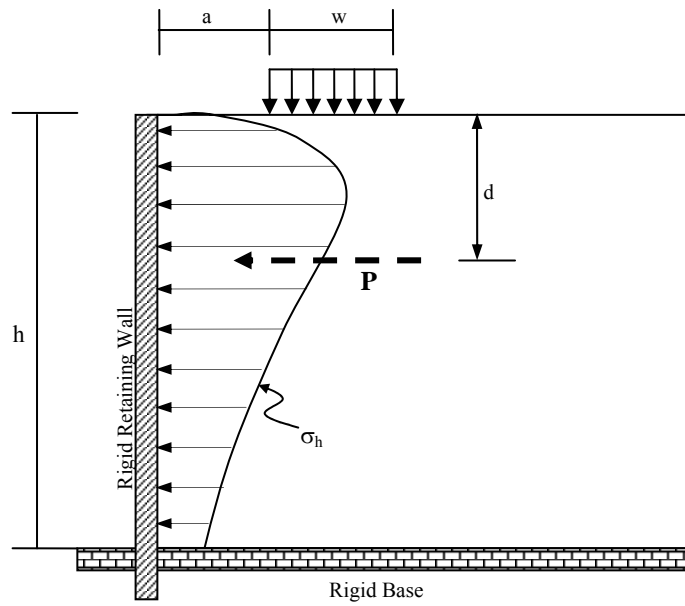

Figure 3. Problem geometry.

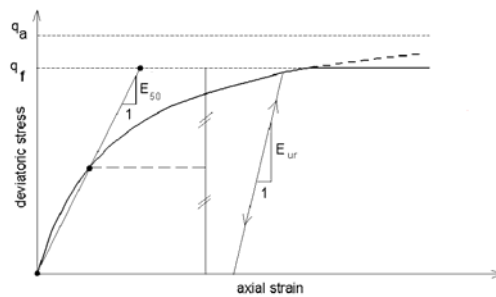

Figure 4. Hyperbolic stress-strain curve for deviatoric loading.

The hyperbolic relationship between the axial strain and deviatoric stress is shown in Figure 4, where q_f is the ultimate deviatoric stress according to Mohr-Coulomb failure criterion with strength parameters c and ϕ . The asymptotic stress q_a is obtained by dividing q_f by a failure ratio R_f which is often used as 0.9. The stress dependent stiffness modulus E_{50} is

$$E_{50} = E_{50}^{ref} \left(\frac{c \cdot \cot(\phi) - \sigma'_3}{c \cdot \cot(\phi) + p^{ref}} \right)^m \quad (8)$$

where σ'_3 is the confining stress, E_{50}^{ref} is the reference modulus (for the mobilization of 50% of the ultimate shear strength q_f) measured in a test at reference confining pressure p^{ref} , m is the stress dependency parameter.

Soil dilatancy and a cap yield surface are included in the model. The problem is modelled in the computer program PLAXIS [17].

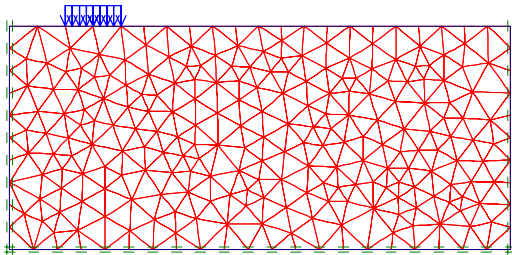

Figure 5. The finite element mesh.

Figure 5 shows a typical finite element model of the problem used in this study. Because the wall is assumed to be rigid and perfectly smooth, it is sufficient to set horizontal fixities on the wall boundary. The lower boundary is vertically restrained to simulate the rigid subgrade. The finite element mesh in Figure 5 is used in all of the analyses. The lateral pressures are computed according to the following procedure:

- 1- The initial stresses are calculated according to Jaky's formula ($K_0 = 1 - \sin\phi$).
- 2- The total stresses are calculated after the surface strip load is applied.
- 3- The lateral pressures due to surface strip load are obtained by subtracting the initial stresses (obtained at step 1) from the total stresses (obtained at step 2).

4. FINITE ELEMENT ANALYSES

In order to keep the input parameters at a minimum, preliminary analyses were conducted to determine the effective problem parameters on lateral earth pressure. These analyses revealed that cohesion and internal angle of friction of soil are the most significant material parameters [18]. Naturally, load magnitude, height of wall, distance of the strip load to the wall and the strip load width are the other effective parameters that should be considered. Finally, the following six parameters are chosen to be considered in the model:

- * Height of the wall, h
- * Distance of the strip load to the wall, a
- * Width of the strip load, w
- * Magnitude of the strip load, q
- * Internal angle of friction for the soil, ϕ
- * Cohesion of the soil, c

The other parameters required for the analyses using Hardening Soil model are given typical values:

- E_{50}^{ref} : 30000 kN/m² (for $p_{ref} = 100$)
- E_{oed}^{ref} : 30000 kN/m² (for $p_{ref} = 100$)
- m : 0.5
- R_f : 0.9
- ψ : 0
- γ : 20 kN/m³

To obtain a solution by neural networks, an input-output pattern is given to the network and the network is trained to find the relation between the input and output data.

The input data is prepared to cover sufficient cases of different material and geometrical parameters. The selected ranges for these parameters are

- Height of the wall (h): 2m – 10m
- Distance of the strip load (a): 0m – 5m
- Width of the strip load (w): 0.5m – 3m
- Magnitude of the strip load (q): 2.5 kN/m² – 50 kN/m²
- Cohesion of the soil (c): 0 kN/m² – 20 kN/m²
- Angle of friction (ϕ): 25° – 40°

Analyses are made for various values of these parameters for the preparation of data for the ANN model. Seventy different cases are considered in this study.

5. ARTIFICIAL NEURAL NETWORK MODEL

The computer program MATLAB together with the Neural Network Toolbox is employed for the modelling. It is proposed to find a relationship between the six input data (h , a , w , q , c , ϕ) and two output variables (total lateral thrust "p" and point of application "d"). A two-layered feed-forward back-propagation type neural network is used. The basic characteristics of the neural network model used in this study can be summarized as follows:

- * Network type: Feed-forward back-propagation

- * Training algorithm: Levenberg-Marquardt algorithm
- * Adaption learning function: Gradient descent with momentum
- * Performance function: Mean square error
- * Number of Layers: 2
- * Transfer function (1st layer): Sigmoid (Figure 7)
- * Transfer function (2nd layer): Linear or sigmoid

The two sigmoid functions of log-sigmoid and tan-sigmoid shown in Figure 6 are commonly used as transfer functions in in neural networks that backpropogation algorithm is used, because they are differentiable. The log-sigmoid function takes the input and squashes the output into the range of 0 – 1. Similarly the tan-sigmoid function takes the input and squashes the output into the range of -1 – 1. The expressions of these functions are given in equations 9 and 10.

$$a = \text{log sig}(n) = \frac{1}{1 + e^{-n}} \tag{9}$$

$$a = \text{tan sig}(n) = \frac{e^n - e^{-n}}{e^n + e^{-n}} \tag{10}$$

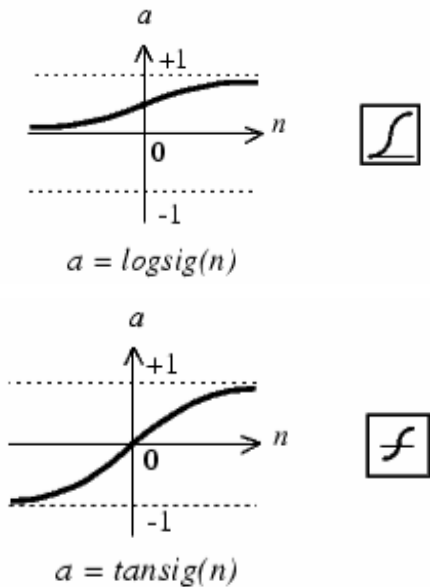

Figure 6. The sigmoid transfer functions (from MATLAB® User’s Guide).

Figure 7 shows the neural network model used in this study for a K element input pattern and M element output pattern. In the figure, the dimensions of the vectors and matrices are shown below the symbols. Superscripts are used to indicate the layers which the corresponding vector or matrix is associated with.

The input vector p^1 is represented by the solid dark vertical bar at the left. The input vector is multiplied by the input weight matrix ($IW^{1,1}$). A constant 1 is multiplied by the scalar bias vector b^1 . The net input to the transfer function, n^1 , is the sum of the bias b^1 and the product $IW^{1,1}p^1$. This sum is passed to the transfer function to get the first layer’s output vector a^1 . Note that, to obtain an $S \times 1$ output vector, the dimensions of $IW^{1,1}$ and b^1 should be $S \times K$ and $S \times 1$ where the input consists of K elements. The output of the first layer, a^1 , can be accepted as an input vector for the second layer. Similar to the first layer, a^1 is multiplied by the layer weight ($LW^{2,1}$) and the bias vector b^2 is added and the net input to the transfer function (which is pure linear function for the second layer), n^2 , is obtained. The output of the second layer and the network is obtained by passing the n^2 to the transfer function. It is also noted that, in order to obtain an output vector of M elements, the dimensions of $LW^{2,1}$ and b^2 must be $M \times S$ and $M \times 1$ respectively.

6. TRAINING THE ANN

The parameters a (distance of the strip load to the wall), w (width of the strip load) and d (distance between the point of application of the total thrust and surface) are normalized by the height of the wall (h). The total lateral thrust “p” is divided by the strip load magnitude q . Therefore the six input and the two output parameters take the form

Input : $h, a/h, q, c, \phi, w/h$

Output : $p/q, d/h$

Several networks with different properties are trained to find the relationship between the selected input-output patterns. For this purpose, networks with different transfer functions are set up and trained. Another important property of a network that affects the accuracy of the network is the number of neurons in the hidden layer (the dimensions of the weight and bias matrices in the hidden layer). Thus, networks with various numbers of neurons in the hidden layer are also trained. An accurate solution is obtained with 15 neurons in the hidden layer.

In the final artificial neural network model (solution network), the maximum errors in p/q and d/h values do not exceed 0.25% and 1% respectively, thus the neural network model successfully covers the 70 cases considered in the training. Table 1 summarizes the errors involved in ANN model.

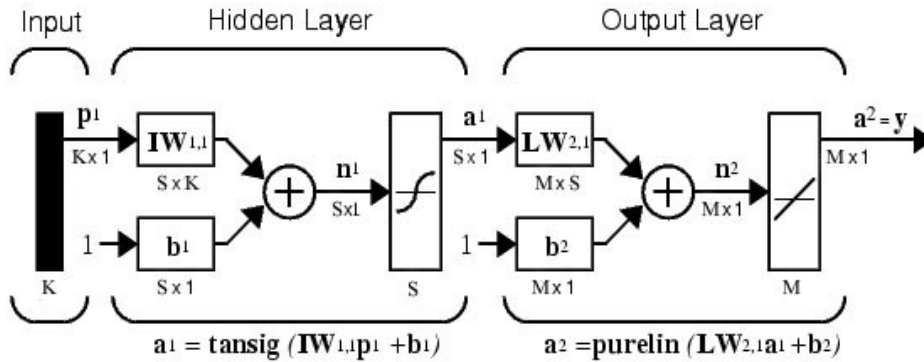

Figure 7. Typical feed-forward back-propagation type neural network (from MATLAB® User’s Guide).

Table 1. Error levels associated with the solution network.

	p/q (m ²)	d/h (dimensionless)
Maximum error (%)	0.22	0.95
Average error (%)	0.02	0.14

7. RESULTS

The solution obtained by ANN can be expressed in closed form as

$$T = LW \cdot \tan \text{sig}(IW \cdot K + B1) + B2 \tag{11}$$

The input vector K and the output vector T are:

$$K = \begin{bmatrix} h \\ a/h \\ q \\ c \\ \phi \\ w/h \end{bmatrix} \text{ and } T = \begin{bmatrix} p/q \\ d/h \end{bmatrix} \tag{12}$$

- Here, h : Height of the wall (m)
- a : Distance of the strip load to the wall (m)
- w : Strip load width (m)
- q : Strip load magnitude (kPa)
- c : (Effective) cohesion of the soil (kPa)
- φ: (Effective) angle of friction of the soil (°)
- p : Total lateral force on the wall due to only strip load (kN)
- d : Distance between the point of application of P and the ground surface (m)

The weight and bias matrices (LW, IW, B1 and B2) are given in appendix A. Given the six inputs, vector K, the outputs, vector T, containing p/q and d/h can be computed by using equation 11.

It should be noted that equation 11 is valid under the assumptions stated before; that is, to obtain accurate and reasonable results from this neural network

solution, the input parameters must lie in the range used in training of the network. It is not recommended, for instance, to use this solution for a strip load width of 5 m, because in the solution width parameter changes between 0.5 m and 3 m.

8. APPLICATION OF ANN MODEL

It has been shown that the ANN solution is successfully fits the 70 training cases. However, the response of the network in other cases excluding those considered in the training process must also be investigated to check the validity of the solution. For this purpose, four new cases are considered. The parameters of these are given in Table 2. These four cases are investigated both by the ANN solution and PLAXIS. The results of p, d and the base moment (moment = p x (h-d)) by both solution methods are shown in Table 3.

It can be seen from Table 3 that the neural network results are very similar to the results obtained from PLAXIS analyses. Hence, it can be concluded that the neural network solution given by equation 11 is reasonably accurate in other cases also.

9. THE EFFECT OF INPUT PARAMETERS ON THE SOLUTION

Individual effects of input parameters a, w, q, c and φ are investigated by using the neural network solution. The linear elastic solution is also plotted on the same graphs.

To investigate the effect of the distance of the strip load (a), the parameters are held constant at h = 6 m, w = 1 m, q = 25 kPa, c = 10 kPa, φ = 30° and the results are obtained for different a values. The results are shown in Figures 8 and 9.

Table 2. Input parameters for the considered 4 cases.

case	h(m)	a(m)	q(kPa)	c(kPa)	ϕ	w(m)
1	3	1.5	15	5	30	1.5
2	5	2.5	25	15	35	2.5
3	7	3	40	10	25	1
4	9	1	30	0	30	2

Table 3. Results of two solution methods.

case	neural network results			plaxis results		
	p(kN)	d(m)	Moment(kN.m)	p	d	Moment(kN.m)
1	7.0	2.0	14.0	7.1	1.9	13.5
2	15.3	3.5	53.6	18.1	3.3	59.7
3	20.6	3.2	65.9	18.7	3.1	58.0
4	41.2	2.0	82.4	38.1	2.3	87.6

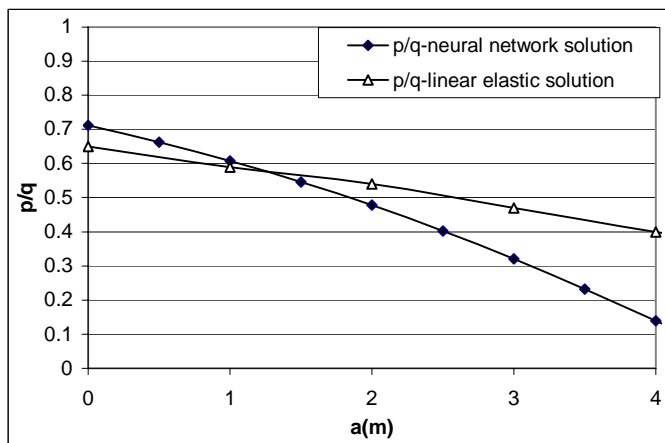

Figure 8. The effect of strip load distance (a) on p/q (m^2).

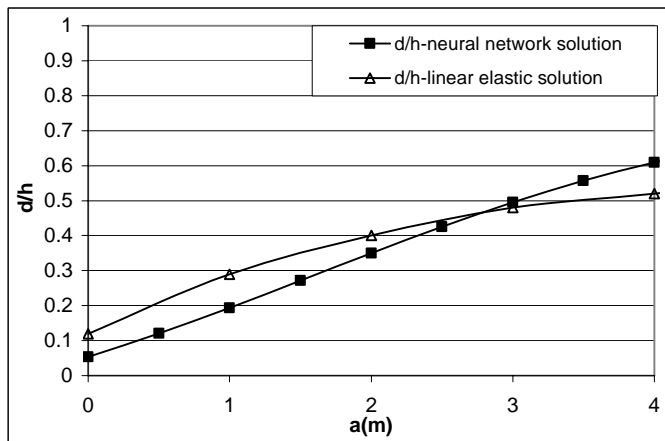

Figure 9. The effect of strip load distance (a) on d/h .

It can be seen from the figures that p/q decreases and d/h increases with increasing a as expected. The linear elastic solution and the neural network solution start to deviate significantly for $a > 2$ m; in this range the linear elastic solution gives higher total thrust values than those by the neural network solution.

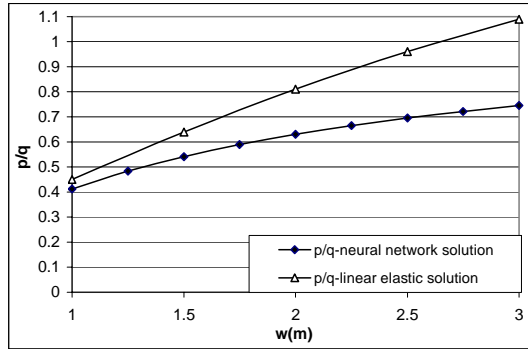

Figure 10. The effect of strip load width (w) on p/q (m^2).

Figures 10 and 11 show the effect of strip load width (w) on p/q and d/h for the case when $h=4$ m, $a=2$ m, $q=25$ kPa, $c=10$ kPa, $\phi=30^\circ$. It is seen that the linear elastic solution gives larger p/q values, especially for larger values of w . In contrast, ANN expression predicts greater d/h values. The effect of q on p/q and d/h is investigated for the case when $h=6$ m, $a=2$ m, $w=2$ m, $c=10$ kPa and $\phi=30^\circ$. The results are shown in Figure 12. It is clear from the figure that the neural network results are very similar to linear elastic solution and nearly constant for d/h . However, due to extensive plastic yielding in the soil mass a significant decrease in p/q values is observed in the neural network solution beyond a critical load level.

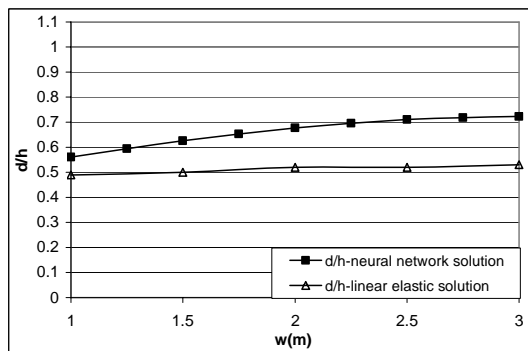

Figure 11. The effect of strip load width (w) on d/h .

The effect of cohesion (c), while the other input parameters are held constant as $h=4$ m, $a=2$ m, $w=2$ m, $q=25$ kPa, $\phi=30^\circ$, is shown in Figure 13. It can be seen that d/h keeps nearly constant for varying cohesion, but the value of d/h obtained by ANN's is significantly greater than those obtained from linear elasticity. It is also clear that the p/q significantly decreases for increasing cohesion and the linear elastic solution gives much higher values for larger values of cohesion.

The effect of angle of friction is very similar to that of cohesion, as shown in Figure 14. To investigate the effect of angle of friction, the case: $h=5$ m, $a=1.5$ m, $w=2$ m, $q=25$ kPa, $c=5$ kPa is considered. Similar to cohesion results, the d/h values are nearly constant and larger than those obtained by linear elastic solution, and there is a significant decrease in p/q for increasing angle of friction resulting in a big difference between the neural network and elastic solutions.

Therefore it can be concluded that the cohesion and angle of friction have negligible effect on the shape of the lateral pressure distribution, while the pressure amplitudes decrease with increasing soil strength (cohesion or angle of friction).

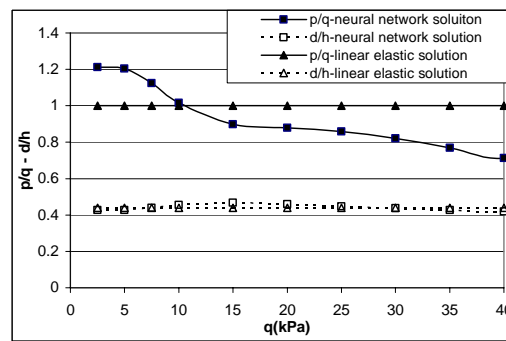

Figure 12. The effect of strip load magnitude (q) on $p/q(m^2)$ and d/h .

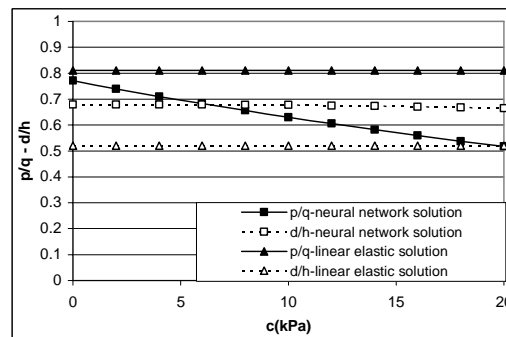

Figure 13. The effect of cohesion (c) on $p/q(m^2)$ and d/h .

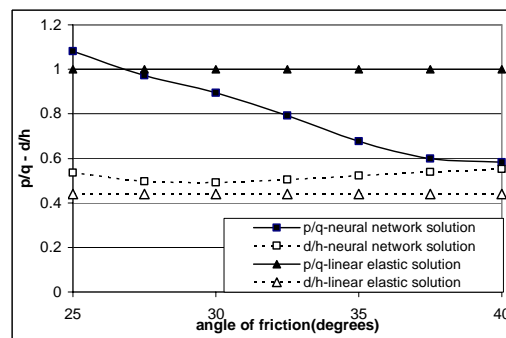

Figure 14. The effect of friction on $p/q(m^2)$ and d/h .

10. CONCLUSIONS

In this study, an investigation of the lateral pressures acting on rigid retaining walls due to surface strip loading has been made. Artificial neural networks (ANN) are used to find a closed form solution. The ANN is trained by the data obtained from non-linear finite element analyses of 70 different cases. A closed form solution, equation 11, with 1% accuracy is reached. The closed form solution computes the total lateral thrust and its point of application as a function of the following six parameters:

- Height of the wall (h)
- Distance of the strip load (a)
- Width of the strip load (w)
- Magnitude of the strip load (q)
- Cohesion of the soil (c)
- Angle of internal friction (ϕ)

The following conclusions have been drawn:

- Within the proper ranges of input parameters, the closed form expression successfully estimates total lateral thrust and its point of application.
- The shear strength of the soil has a considerable effect on the total lateral thrust. An increase in the shear strength parameters (cohesion or angle of friction) result in a decrease in the total lateral thrust.
- Although the shear strength parameters affect the total lateral thrust, they have negligible effect on the point of application of this force. This shows that the shear strength of the soil does not change the profile of the lateral pressure distribution but affects the lateral pressure magnitude.
- The linear elastic solution generally gives larger total thrust values than those predicted by the ANN solution based on non-linear plastic analyses. The difference increases as strip load width, cohesion and friction angle increase.
- The point of application predicted by the neural network solution is generally lower than that given by the linear elastic solution.
- The neural network solution presented is valid within the assumptions adopted here. ANN models based on different assumptions, with different parameter ranges can be investigated separately; among others, for instance, flexible walls instead of rigid walls can be considered.

APPENDIX A

WEIGHT AND BIAS MATRICES OF THE SOLUTION NETWORK

IW =

0.707584	1.669341	-0.012751	0.096040	-0.344573	-0.006084
0.290101	-0.285203	-0.020045	-0.016270	0.025231	1.034413
0.025184	1.675913	0.003187	-0.011426	-0.013588	0.989599
-0.218160	-0.334959	-0.017237	0.027217	0.123004	0.904165
0.236921	1.428380	-0.062918	0.054190	-0.064349	-3.940876
0.401155	-0.765628	-0.009593	-0.025510	0.010007	-0.210672
0.043779	0.449645	0.015901	-0.013441	-0.074459	-0.846834
-0.507689	-0.227599	-0.008705	0.016337	-0.015705	1.468541
-1.375848	-5.436067	0.646734	0.134772	0.119914	18.519199
0.363906	2.833471	-0.186603	0.100430	-0.101867	-3.190632
-0.418049	0.099324	-0.020282	0.065495	0.154286	-0.840888
0.512810	0.166012	0.007541	-0.016510	0.021023	-1.449474
0.355588	-0.228980	-0.009691	-0.008272	0.115341	0.026844
-3.261537	-1.695312	0.612241	-0.075086	0.599992	-15.115130
1.586981	-2.223672	0.079581	-0.178878	0.927314	8.396568

B1 =

-0.387163	11.043619
-2.698834	1.207034
-0.234439	
-2.926085	
0.829085	
-2.426979	
1.867292	
1.387967	
-29.263770	
1.504808	
-0.598197	
-1.504389	
-3.650848	
9.602564	
-31.920627	

B2 =

11.043619
1.207034

dimension of IW = 15 x 6
 dimension of LW = 2 x 15
 dimension of B1 = 15 x 1
 dimension of B2 = 2 x 1

LW (columns 1 to 5) =

10.590286	-0.014567	0.017771	-1.880257	-0.605940
0.861373	-0.431648	0.722998	-0.114303	0.133397

LW (columns 6 to 10) =

-0.678839	-3.097798	-7.987459	0.117518	0.376596
0.289137	-0.579776	4.443063	0.028310	-0.066399

LW (columns 11 to 15) =

-1.154965	-7.790873	-0.459319	0.223971	0.252342
-0.088841	4.795814	-0.597022	-0.001774	0.081540

REFERENCES

- [1] Misra, B., "Lateral pressures on retaining walls due to loads on surfaces of granular backfills", *Soils and Foundations*, 20(2): 33-44 (1981).
- [2] Jarquio, R., "Total lateral surcharge pressure due to strip load", *J. Geotech. Engrg., ASCE*, 107: 1424-1428 (1981).
- [3] MATLAB, "User's guide", *The MathWoks Inc.*, Natic, MA 01760-2098 (2002).
- [4] Neural Network Toolbox, "Users's guide", *The MathWoks Inc.*, Natic, MA 01760-2098 (2003).
- [5] Rumelhart, D.E., McClelland, J.L., the PDP Research Group, "Parallel distributed processing", *The MIT Press*, Cambridge, Vol:1 (1986).
- [6] McClelland, J.L., Rumelhart, D.E., "Explorations in parallel distributed processing", *The MIT Press*, Cambridge (1988).
- [7] Dayhoff, J.E., "Neural network architectures", *Van Nostrand Reinhold Press*, New York (1990).
- [8] Hagan, M.T., Demuth, H.B., Beale, M.H., "Neural network design", *MA: PWS Publishing*. Boston (1996).

- [9] Hagan, M.T., Menhaj, M., "Training feed-forward networks with the Marquardt algorithm", **IEEE Transactions on Neural Networks**, 5(6): 989-993 (1994).
- [10] Poulos, H.G., Davis, E.H., "Elastic solutions for soil and rock mechanics", **John Wiley and Sons**, New York (1974).
- [11] Motta, E., "Generalized coulomb active earth pressure for distanced surcharge", **J. Geotech. Engrg., ASCE**, 120: 1072-1079 (1994).
- [12] Georgiadis, M, Anagnostopoulos, C., "Lateral pressure on sheet pile walls due to strip load", **J. Geotech. and Geoenv. Engrg., ASCE**, 124: 95-98 (1998).
- [13] Cernica, J.N., "Geotechnical engineering: foundation design", **John Wiley & Sons Inc.**, New York (1995).
- [14] Schanz, T., Vermeer, P.A., Bonnier, P.G., "The hardening soil model: formulation and verification", **Beyond 2000 in Computational Geotechnics-10 years of Plaxis**, Balkema, Rotterdam (1999).
- [15] Duncan, J.M., Chang, C.Y., "Nonlinear analysis of stress and strain in soil", **J. of the Soil Mech. and Found. Div., ASCE**, 96: 1629-1653 (1970).
- [16] Duncan, J.M., Byrne, P., Wong, K.S., Babry, P., "Strength, stress-strain and bulk modulus parameters for finite element analyses of stresses and movements in soil masses", **University of California, Berkeley**, Report No: UCB/GT/80-01 (1980).
- [17] Brinkgreve, R.B.J. [Ed], "PLAXIS-Finite element code for soil and rock analyses: user's manual-V 8", **AA Balkema**, Rotterdam, Netherlands (2002).
- [18] Yildiz, E., "Lateral pressures on rigid retaining walls: a neural network approach", M.Sc. Thesis, **Middle East Technical University**, Ankara, Türkiye (2003).