



Neural Network Based Selective Harmonic Elimination with Improving the THD in Low Modulation Indexes

Ali AJAMI^{1,*}, Farhad Mohajel KAZEMI¹, Ata Ollah MOKHBERDORAN¹,
Babak NAYERI¹

¹ *Electrical Engineering Department of Azarbaijan Shahid Madani University*

Received: 03.11.2012 Revised: 27.05.2013 Accepted: 09.06.2013

ABSTRACT

Multilevel converters are on the state-of-the-art in power conversion systems due their improved voltage and current waveforms. Selective Harmonic Elimination Pulse Width Modulation (SHEPWM) switching strategy is commonly applied for the elimination of low order harmonics in the multilevel converter with stepped waveform. In this paper, a new approach of this switching algorithm is utilized to a seven-level cascaded converter to produce the required fundamental voltage and in the same time cancel out specified order harmonics. In this paper to solve SHE nonlinear transcendental, resultant theory has been used. Result angles obtain from resultant theory are trained to neural network, since the neural network is trained, gives the best angles for the entire modulation index. In the seven-level converter, the switching angles can be chosen to produce the desired fundamental output while making the fifth and seventh harmonics identically zero. But the main drawback is that for some ranges of the modulation index (m) there are not any solutions in resultant theory, to overcome this problem and improving the THD at output voltage in lower modulation indexes a DC-DC buck converter has been used to have adjustable dc source in input of converter to coordination between modulation index and output voltage. The simulation results have been carried out using SIMULINK/MATLAB present the effectiveness of the SHEPWM strategy for the proposed converter. In addition, the experimental results of proposed topology prototype have been presented to validate its practicability.

Keywords: Multilevel converters, Neural network, resultant theory, SHEPWM

1. INTRODUCTION

Multilevel converters can be regarded as voltage synthesizers, in which the desired output voltage is created by several discrete smaller DC voltages [1]. Increasing the number of dc voltage-sources causes the converter output voltage reaches to a nearly sinusoidal waveform. In this state a fundamental frequency switching method has been used [2].

The main advantages of the multilevel converter in comparison with the traditional two-level voltage converters are: lower value of Total Harmonic Distortion (THD), better power quality, higher amplitude of fundamental component, better electromagnetic compatibility, and the switches experience lower voltage stresses [1, 2].

Based on the features of multilevel converters, these converters are the most applicable for the high or medium voltage range such as power distribution,

*Corresponding author, e-mail: ajami@azaruniv.edu

motor drives, power quality and power conditioning applications. Also to expand the converter operating voltage area using general semiconductors the multilevel converter is introduced as a solution [3]. Multilevel topologies are classified into three important categories: diode-clamped, flying capacitor, and cascaded multilevel structures. Recently, with developing in the power electronic semiconductors rating the new topologies of multilevel converters has been interested by researchers [4]. The main advantage of cascaded multilevel topology respect to diode-clamped and flying capacitor is its simplicity. The diode-clamped and flying capacitor configurations need more capacitors and diodes whereas the cascaded topology requires more isolated DC voltage source. So the complexity of control strategy to regulate the voltage across each capacitor is the main disadvantage in flying capacitor and diode-clamped converters [4].

For switching multilevel converters many different methods can be applied which respect to the switching frequency classified into two categories. Methods that work with high switching frequencies and in other hand methods that works with low switching frequencies. Some of the high frequency methods including classical carrier based Sinusoidal Pulse Width Modulation (SPWM) and the Space Vector Modulation (SVM). Low frequency methods generally mean the fundamental component frequency and generate a staircase waveform. Representatives of this family are Minimization of the Total Harmonic Distortion (MTHD), Space Vector Control (SVC), and Selective Harmonic Elimination PWM (SHEPWM) [5]. In the second group, low switching frequency causes switching losses reaches to its minimum level; efficiency is maximized and so its implementation is easy [6].

In SHEPWM technique, firstly the switching angels are calculated to eliminate selective harmonics as off-line through some algorithms such as: Newton-Raphson (N-R), Sequential Quadratic Programming (SQP), Resultant Theory, Homotopy algorithm, Genetic algorithm (GA), PSO and Harmony Search Algorithm (HSA). Then obtained angels applied to PWM control block in order to generate gate signals. Solving the nonlinear equations of SHE using above mentioned methods are so time consuming. Therefore in this paper to overcome this problem the neural network has been used.

In this paper the SHEPWM strategy has been used for generating the gate signals. The resultant theory has been used to solve SHE's nonlinear equations as offline [5]. Obtained angels from resultant theory are used to train the Multi-Layer Perceptron (MLP) neural network [7] for various modulation indexes. After training, neural network generate suitable angels in various modulation indexes to switching cascaded multilevel converter. The nonlinear SHE equations have not solution in some ranges of the modulation indexes. In these areas the output voltage will not be suitable and some levels cannot be generating in output voltage and so the THD of output voltage is increased. In this paper to generate the desired output voltage in modulation

indexes areas without solution the DC input voltage of converter has been changed in such away the nonlinear equations have solution. For this purpose a DC-DC buck converter [8] has been used to change the DC input voltage of cascaded converter. When the input voltage has been changed in order to maintain the output voltage as constant, modulation index changed to value which nonlinear equations have solution.

2. CASCADED MULTILEVEL CONVERTER

Several H-bridge (single-phase full-bridge) converter units in series together comprise cascade multilevel converter. The general application of this multilevel converter is to generate a desired voltage from several isolated dc sources, which may be obtained from fuel cells, batteries, etc. Fig. 1 shows single phase cascade multilevel converter, it is clear that output phase voltage waveform of a cascade multilevel converter is achieved by summing the output voltages of bridges. So output phase voltage of a cascade inverter is obtained by:

$$V_O = V_{O1} + V_{O2} + \dots + V_{On} \quad (1)$$

Assuming the same DC voltage sources for all H-bridge cells, the maximum number of levels of phase voltage is given by:

$$m = 2n + 1 \quad (2)$$

Where, m and n are the maximum number of levels of phase voltage and number of DC voltage source, respectively.

Output voltage in cascaded multilevel converter is generated by summing output voltages of each H-bridge unit which have phase shift respect together. Each switching device always conducts for half of cycle regardless to the pulse width of the quasi-square wave (output voltage of each H-bridge units) so that this switching method results in equalizing the current stress in each active device.

3. PROPOSED METHOD FOR SELECTIVE HARMONIC ELIMINATION

3.1. SHE Nonlinear Equations

The output voltage waveform of the multilevel converter is shown in Fig.2. The Fourier series expansion of output voltage can be written as:

$$V(\omega t) = \frac{4V_{dc}}{n\pi} (\cos n\theta_1 + \cos n\theta_2 + \dots + \cos n\theta_s) \sin(n\omega t) \quad (3)$$

Where V_{dc} is value of each step and s is the number of dc voltages. Ideally, given a desired fundamental voltage V_1 , one wants to calculate the switching angles $\theta_1 \dots \theta_s$ so that (5) becomes $V(\omega t) = V_1 \sin(\omega t)$. In practice, one is left with trying to do this approximately.

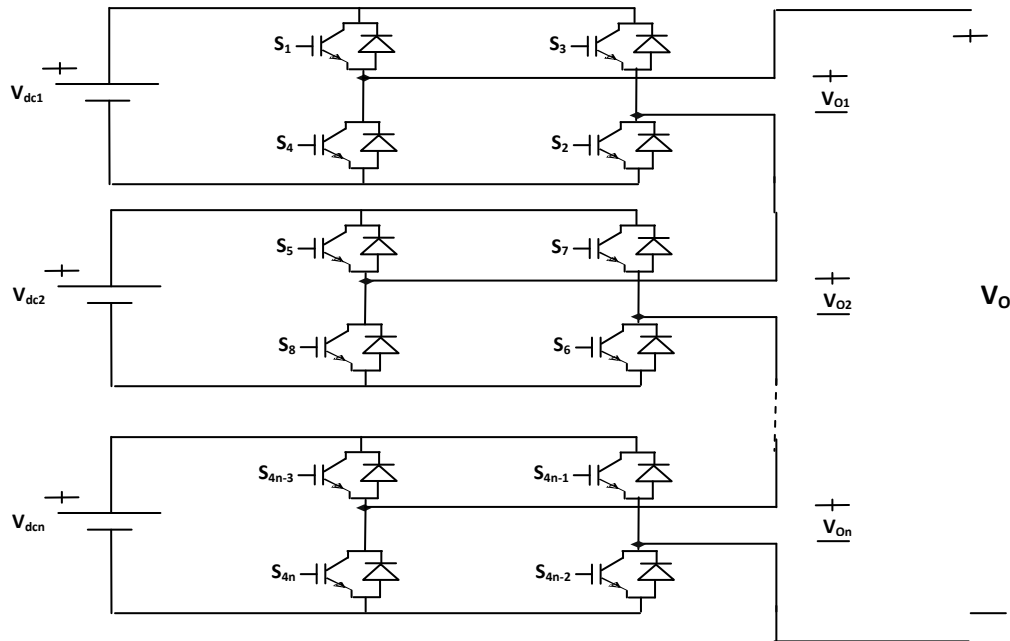

Figure 1. Configuration of cascade multilevel converter.

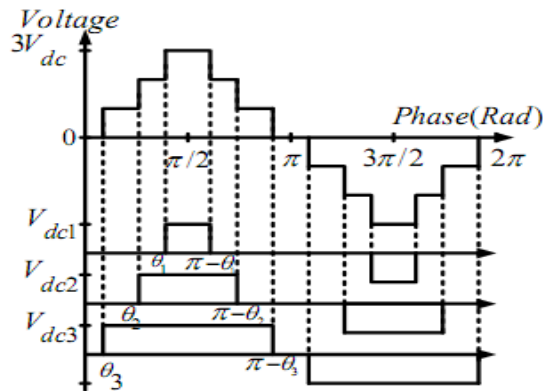

Figure 2. Output waveform of a 7-level multilevel converter.

Eliminating of the lower frequency dominant harmonics and minimizing the total harmonic distortion are two main methods in selecting the switching angles.

Main reasons of more popularity of mentioned methods are: eliminate the lower dominant harmonics and small output filter for removing the higher residual frequencies.

Main goals of suggested method in this paper, is to eliminate the lower frequency harmonics and improving the THD in lower modulation indexes.

In SHE method by determining the switching angles the first harmonic equal to the desired fundamental voltage and specific higher harmonics of equal to zero be obtained. The multiples of third harmonics in each phase need not be canceled as they automatically cancel in the line-to-line voltages. Specifically, in case of $s=3$ dc voltage sources, it is desire to eliminate the fifth-,

and seventh- order harmonics and to obtain desired fundamental component (V_1) [5]. Consequently one obtains:

$$\frac{4V_{dc}}{\pi} (\cos \theta_1 + \cos \theta_2 + \cos \theta_3) = V_1$$

$$\cos 5\theta_1 + \cos 5\theta_2 + \cos 5\theta_3 = 0$$

$$\cos 7\theta_1 + \cos 7\theta_2 + \cos 7\theta_3 = 0 \tag{4}$$

To solving these set of nonlinear equations one approach is to use an iterative method such as the Newton-Raphson method, and other approach is to use resultant theory [5]. If the output voltage of the 7-level converter would not contain the fifth-, seventh- order harmonic components it means that conditions (4) has correct solution [5].

In this paper, resultant theory has been applied to obtain the switching angles ($\theta_1, \theta_2, \theta_3$) for the ranges of modulation indexes m ($m \triangleq V_1 / (4V_{dc}/\pi)$) that a solution exists. Fig.3 shows the switching angles ($\theta_1, \theta_2, \theta_3$) versus m . The modulation index (m) was incremented in steps of 0.01. Note that for m in the range from approximately 1.49 to 1.85, there are two different sets of solutions. On the other hand, for $m = [0, 0.8], m = [0.83, 1.15],$ and $m = [2.52, 2.77],$ there are no solutions for (4).

In which range that there are two sets of solutions which one is selected that gives the smallest value for 11th and 13th harmonics.

3.2. Controlling of Converter's Input

As mentioned, for some ranges of modulation index, the resultant theory has not solution. Therefore to overcome this problem and improving the THD at output voltage in lower modulation indexes a DC-DC buck converter has been used to have adjustable dc source in input of converter to coordination between modulation index and output voltage. Notice that fundamental output

voltage is $V_1 = m * \left(\frac{4V_{dc}}{\pi}\right)$, V_{in} can be controlled by DC-DC converter to change modulation index into ranges that resultant theory has a solution and all levels is generated in output voltage. Fig.4. shows control block of DC-DC converter to create input voltage of inverter (V_{in}) so that in same output voltage modulation index be in range of that resultant theory has a solution.

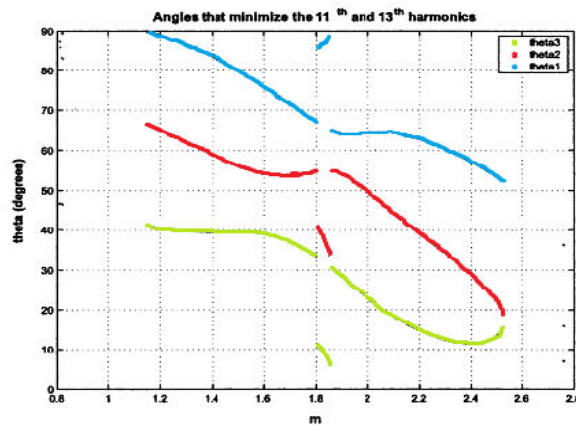

Figure 3. Switching angels θ_1, θ_2 and θ_3 versus m

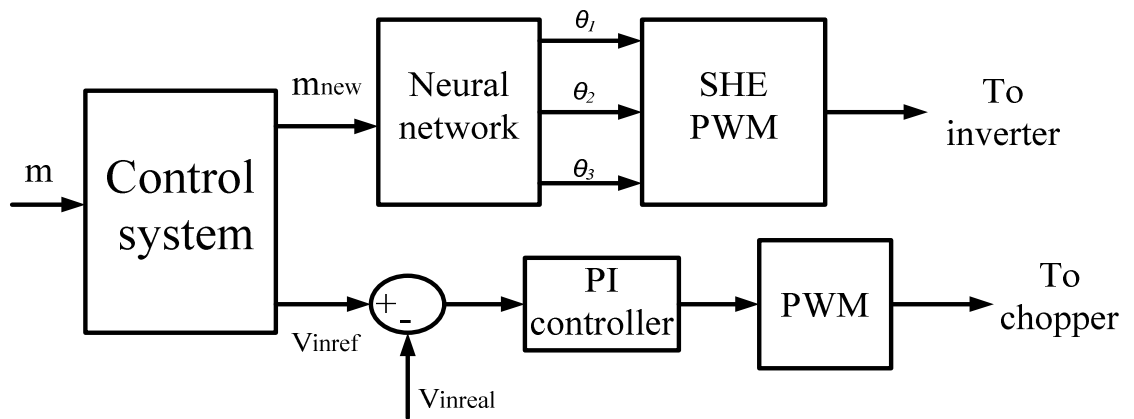

Figure 4. Proposed control system.

For example, when each of DC voltage source is $V_{dc}=300V,$ $m=1$ then $V_1=382V,$ but for this modulation index resultant theory has not any solution, so DC-DC converter changed V_{dc} to $150V$ ($V_{in}=150V$),

and control system changed modulation index (m) to 2, by this values $V_1=382V.$ Fig.5. shows the proposed topology for cascaded multilevel converter.

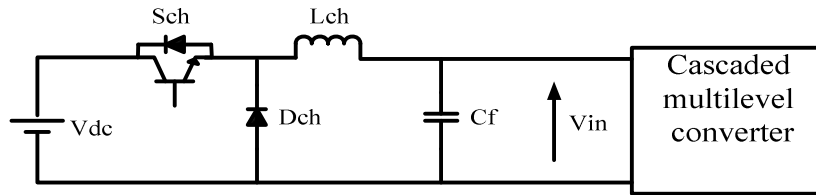

Figure 5. Proposed topology for multilevel converter

3.3. Generator of Switching Angles Based Neural Network

Solving the nonlinear equations of SHE using resultant theory method is so time consuming. Therefore in this paper to overcome this problem the neural network has been used.

Structure of neural network has been used in this paper is shown in Fig.6 [7]. The used structure for neural network is a feed forward network including 10 neurons at first (hidden) layer and 3 neurons in the last (output) layer and activation function (f) is hyperbolic tangent.

Based on obtained results from resultant theory and training process by MATLAB software neural network is trained to generate switching angles.

Back propagation method has been used to train this network is described as follows.

Cost function to training this network is:

$$J = \sum_{i=1}^3 E_i^2 \tag{5}$$

$$E_i = t_i - a_i \tag{6}$$

Where, t_i, a_i are desired angles (output of resultant theory), and output of neural network, respectively. Equations (7), (8) show the process of weight training.

$$W_{ij}^l(k+1) = W_{ij}^l(k) - \alpha \frac{\partial J}{\partial W_{ij}^l} \tag{7}$$

$$\frac{\partial J}{\partial W_{ij}^l} = \frac{\partial J}{\partial E_i} \frac{\partial E_i}{\partial a_i^l} \frac{\partial a_i^l}{\partial n_i^l} \frac{\partial n_i^l}{\partial W_{ij}^l} \tag{8}$$

Where, W_{ij} are weights between output and hidden layers neurons.

Simulation results show that neural network has been trained well and track reference angles obtained from resultant theory to omit fifth and seventh harmonics.

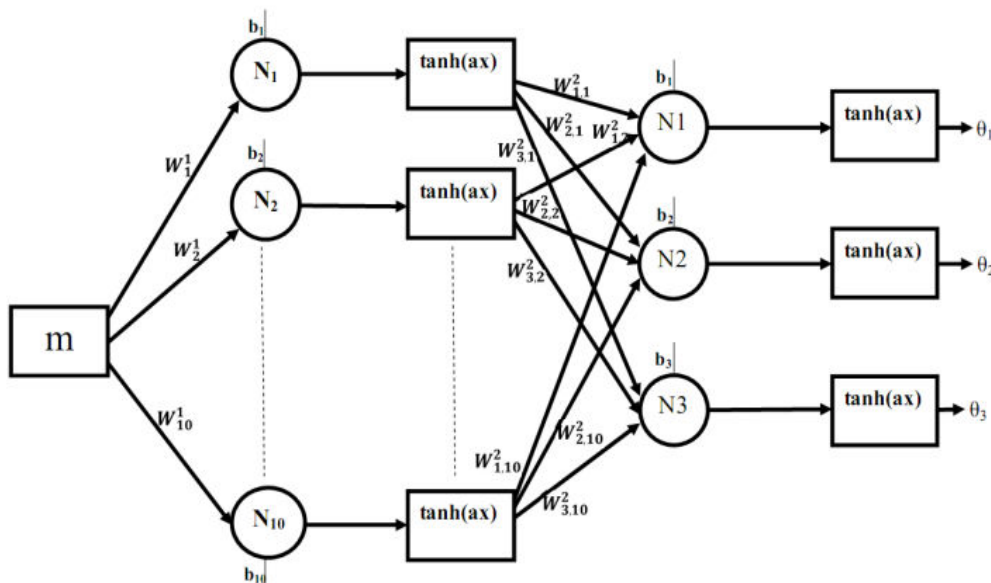

Figure 6. Structure of neural network

4. SIMULATION RESULTS

Simulation results are presented for 4 various modulation indexes for cascaded converter without DC-DC converter and cascaded converter with DC-DC converter in input. The main parameters used in simulations are defined in Table.1. Results show when DC-DC converter is not used, for low modulation indexes number of levels in output voltage is lost, THD

of output voltage is high and specific harmonics that have been selected to omitting cannot be cancelled. When DC-DC converter is used in input of cascaded converter these problems can be solved and output voltage is suitable, THD of output voltage is less than previous state, and specific harmonics are omitted. In all simulation cases, input of DC-DC converter is constant ($V_{dc}=200v$), and 3th harmonic automatically cancel in line-line voltage.

Table1. Load and converter main parameters in simulation

parameters	V_{dc}	L_{ch}	C_f	R_{load}
Value (unit)	200 (v)	10 (mH)	800 (μF)	10 (Ω)

Fig.7. show the results for modulation index ($m=1.8$), in this modulation index resultant theory has a solution, so the input DC voltage of cascaded converter is not changed ($V_{in}=200v$). Output voltage in both states

(without chopper and with chopper) is same. FFT analysis indicates fifth, seventh harmonics are omitted and desired fundamental voltage is generated and also all levels are present in the output voltage.

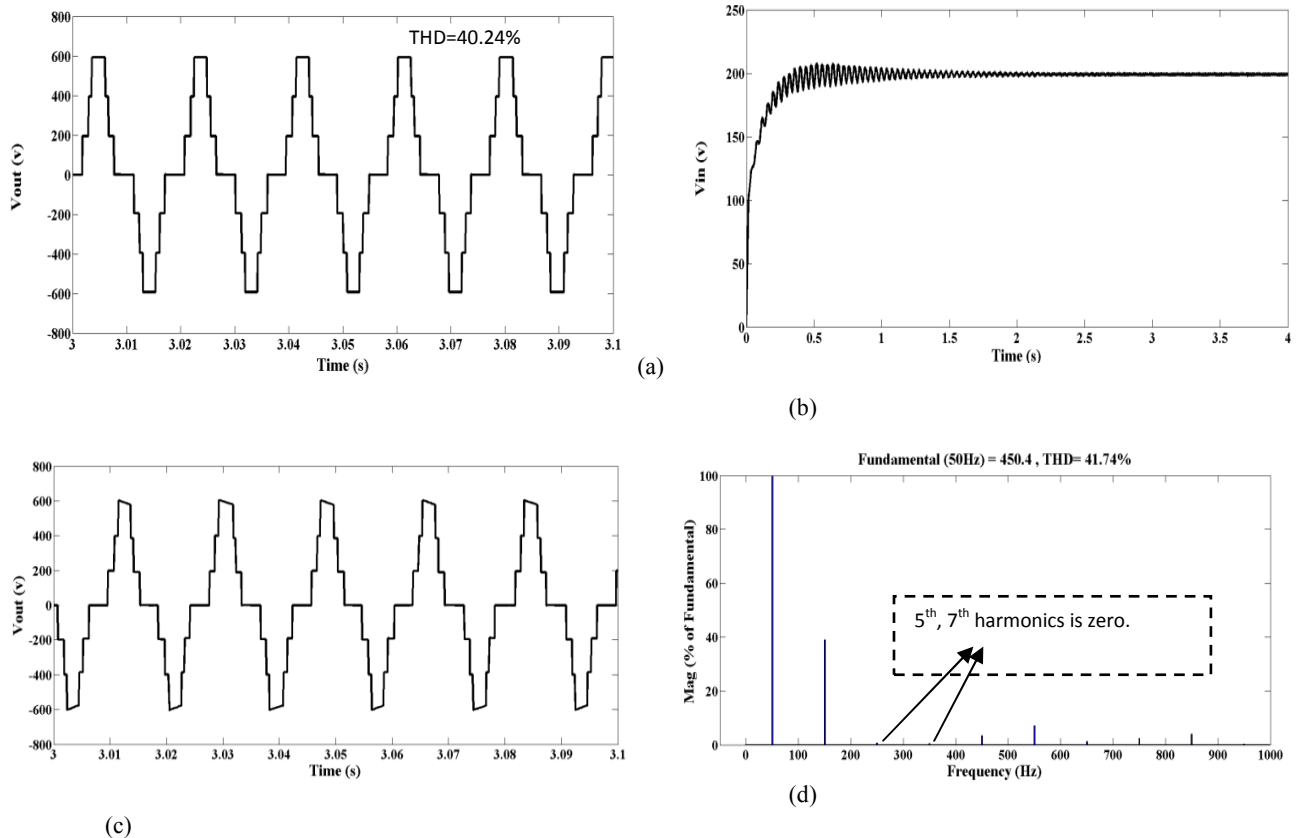

Figure 7. Simulation results for $m=1.8$:a)output voltage without chopper b)input voltage c)output voltage with chopper d)FFT analysis

Fig.8. show the results for modulation index ($m=0.8$), in this modulation index resultant theory has not any solution, output voltage without chopper is not suitable, THD of output voltage is high and number of levels has been lost. So the DC voltage of cascaded converter is

changed to $V_{in}=100v$ by DC-DC converter, in this case to have a same fundamental output voltage control system changed modulation index (m) to ($m=1.6$) that resultant theory has a result. FFT analysis indicates fifth, seventh harmonics are omitted and desired

fundamental voltage is generated. It can be seen from this figure that the output voltage has seven levels.

Fig.9. shows the results for modulation index ($m=0.5$), in this modulation index resultant theory has not any solution, output voltage without chopper is not suitable, THD of output voltage is high and number of levels has been lost. So the DC voltage of cascaded converter is changed to $V_{in}=50v$ by DC-DC converter, in this case to have a same fundamental output voltage control system changed modulation index (m) to ($m=2$) that resultant theory has a result. FFT analysis indicates fifth, seventh harmonics are omitted and desired fundamental voltage is generated.

Fig.10. show the results for modulation index ($m=0.25$), in this modulation index resultant theory has not any solution, output voltage without chopper is not suitable, THD of output voltage is high and number of levels has been lost. So, the DC voltage of cascaded converter is changed to $V_{in}=25v$ by DC-DC converter, in this case to have a same fundamental output voltage control system changed modulation index (m) to ($m=2$) that resultant theory has a result. FFT analysis indicates fifth, seventh harmonics are omitted and desired fundamental voltage is generated.

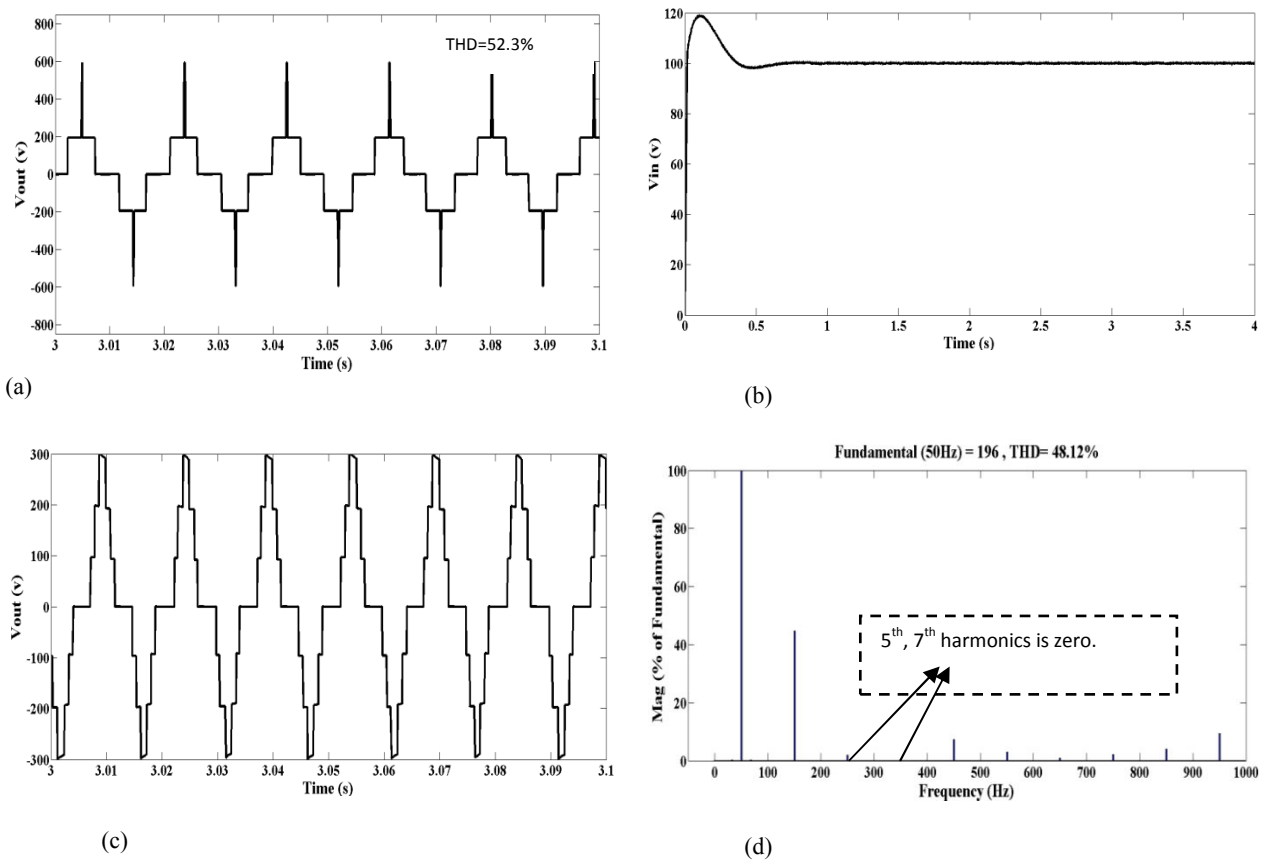
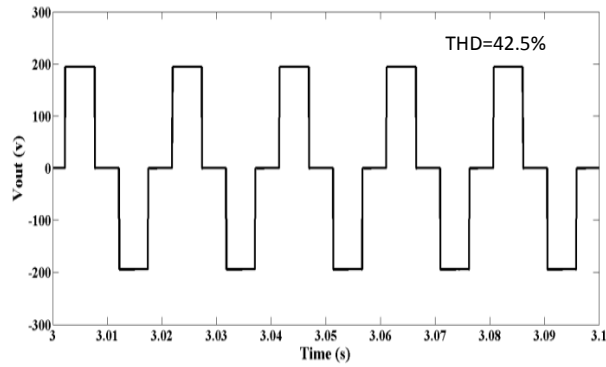
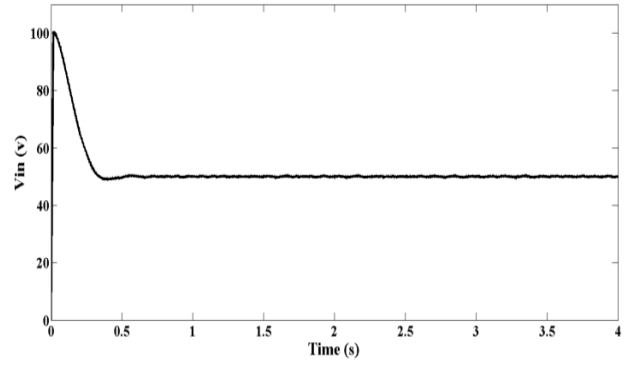

Figure 8. Simulation results for $m=0.8$: a) output voltage without chopper b) input voltage c) output voltage with chopper d) FFT analysis



(a)



(b)

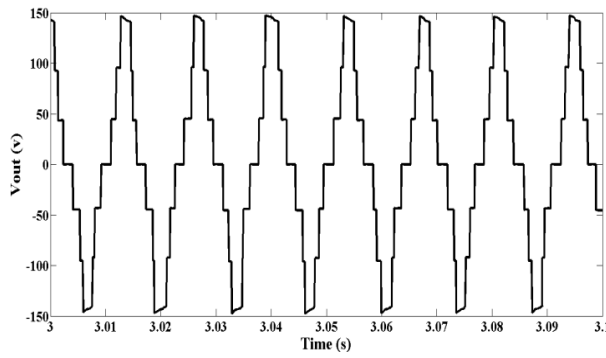

(c)

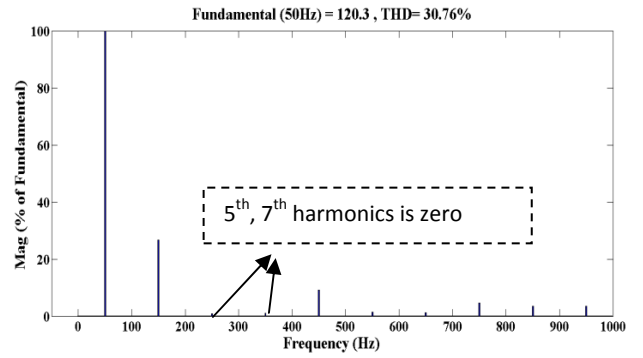

(d)

Figure 9. Simulation results for $m=0.5$: a) output voltage without chopper b) input voltage c) output voltage with chopper d) FFT analysis

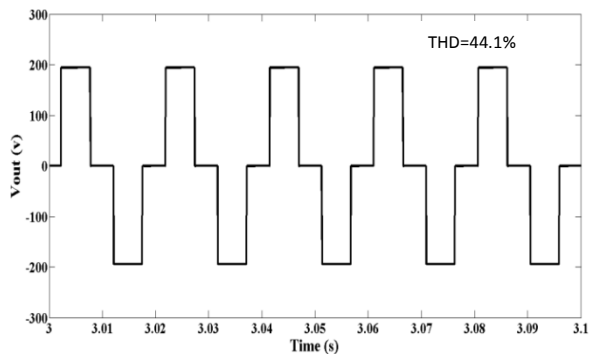

(a)

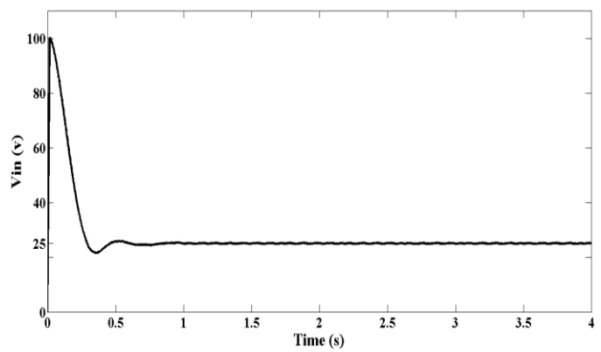

(b)

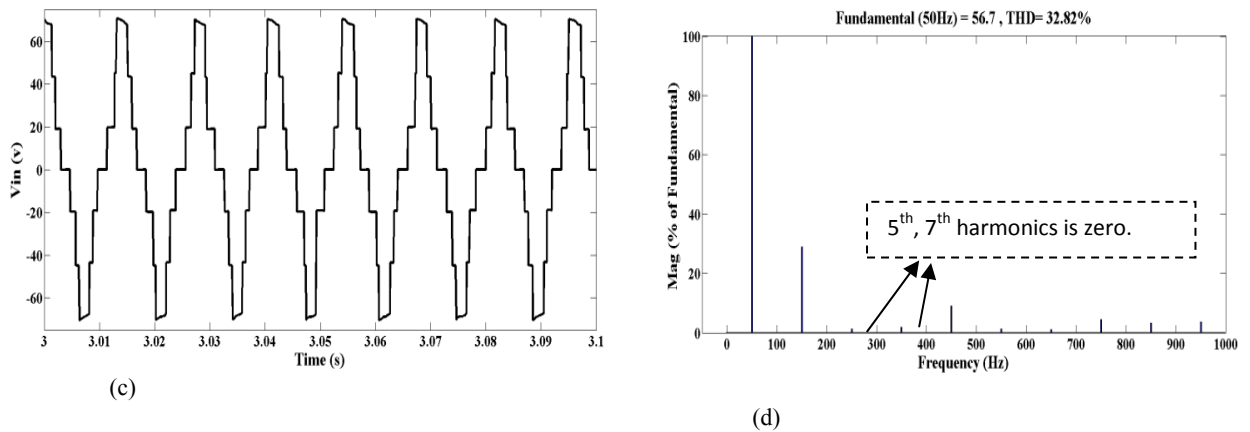
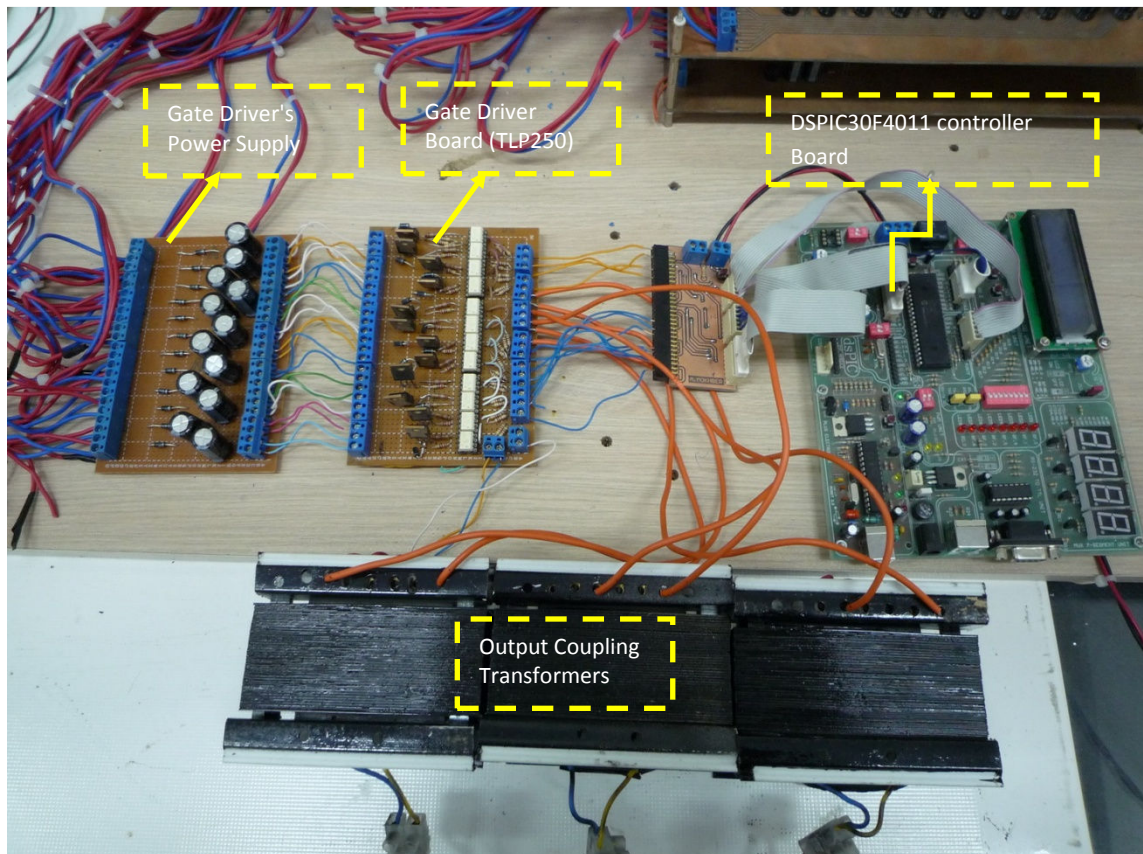

Figure 10. simulation results for $m=0.25$: a) output voltage without chopper b) input voltage c)output voltage with chopper d)FFT analysis

Simulation results show the well performance of cascaded converter with proposed switching algorithm. It is notice that, if multiples of third harmonics cancel in the line-to-line voltages THD percent is very low.

5. EXPERIMENTAL RESULTS

In this paper, a single-phase 7-level cascaded converter has been implemented to validate the practicability of proposed switching algorithm based on neural network in order to selective harmonic elimination. Fig. 11 shows the implemented prototype. The DC input voltage of chopper is 75V and R-L load is 120Ω -250mH.



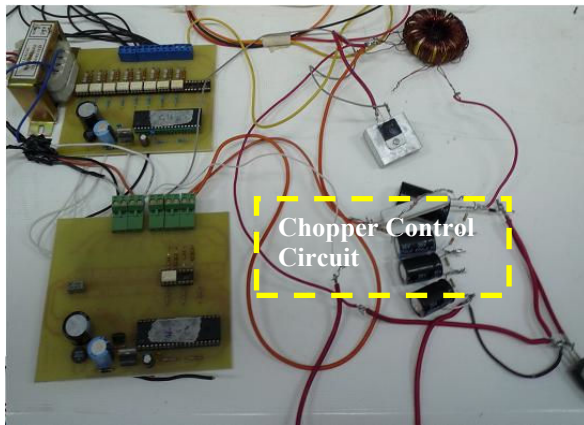
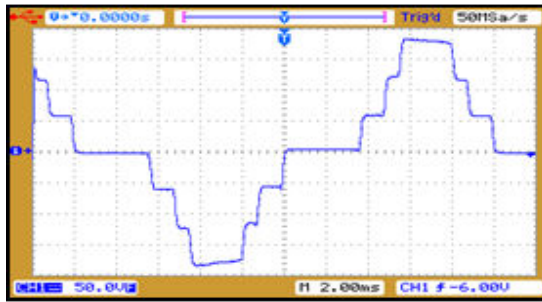

Figure 11. Implemented prototype setup

Fig.12 show the experimental results for modulation index ($m=1.8$), in this modulation index resultant theory has a solution, so the input DC voltage of cascaded converter is not changed ($V_{dc}=75v$). The FFT analysis

shows fifth, seventh harmonics are omitted and desired fundamental voltage is generated and also all levels are present in the output voltage.



(a)

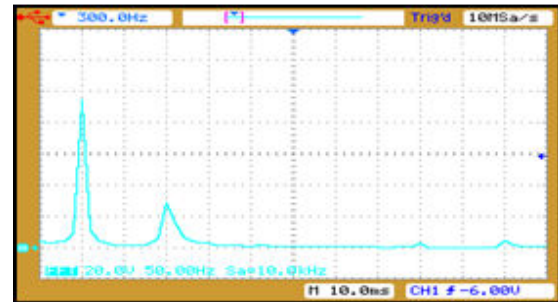

(b)

Figure 12. Experimental results for $m=1.8$: a) output voltage b) FFT analysis

Fig.13. show the experimental results for modulation index ($m=0.8$), in this modulation index resultant theory has not any solution, as mentioned in simulation results output voltage without chopper is not suitable, THD of output voltage is high and number of levels has been lost. So the DC voltage of cascaded converter is changed to $V_{dc}=37.5v$ by DC-DC converter, in this case to have a same fundamental output voltage control system changed modulation index (m) to ($m=1.6$) that resultant theory has a result. FFT analysis indicates fifth, seventh harmonics are omitted and desired fundamental voltage is generated. It can be seen from this figure that the output voltage has seven levels.

Fig.14 and Fig.15 show the experimental results for modulation indexes ($m=0.5$) and ($m=0.25$) respectively, in this modulation indexes resultant theory has not any solution, output voltage without chopper is not suitable, THD of output voltage is high and number of levels has been lost. So the DC voltage of cascaded converter is changed to $V_{dc}=19v$ and $V_{dc}=8.5v$ by DC-DC converter respectively. To have a same fundamental output voltage control system changed modulation indexes (m) to ($m=2$) in both cases that resultant theory has a result. FFT analysis indicates fifth, seventh harmonics are omitted and desired fundamental voltage is generated. It can be seen from this figure that the output voltage has seven levels.

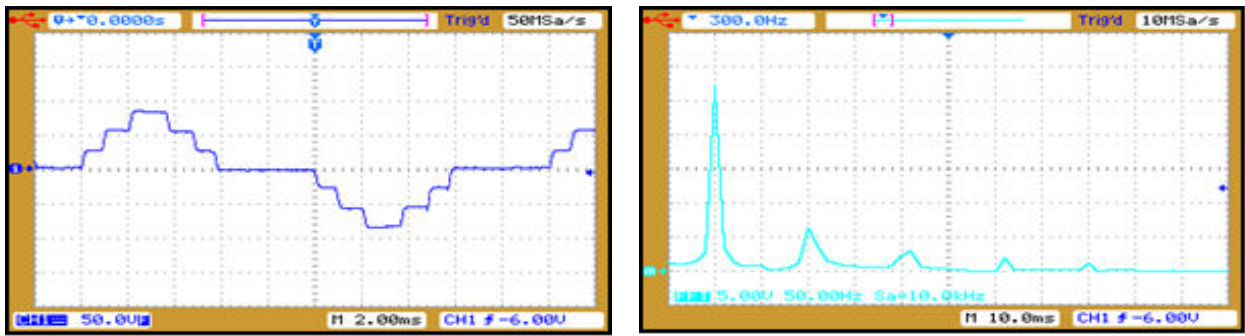

(a) (b)

Figure 13. Experimental results for $m=0.8$: a) output voltage b) FFT analysis

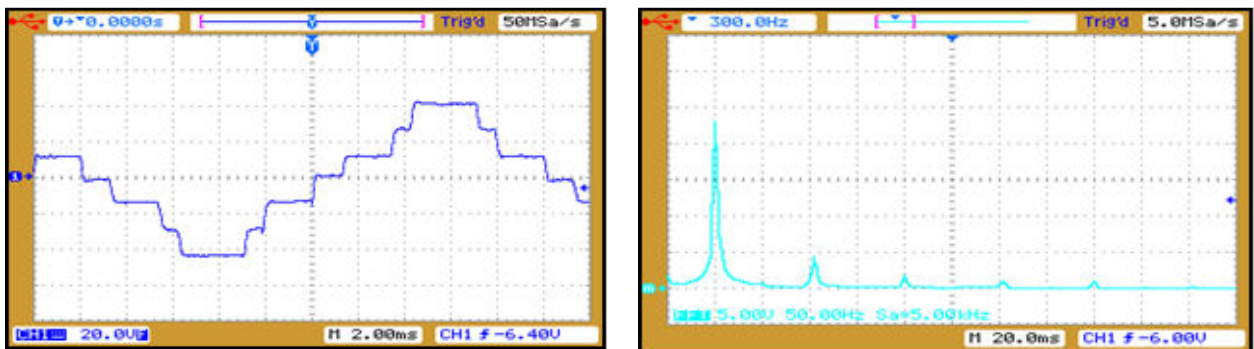

(a) (b)

Figure 14. Experimental results for $m=0.5$: a) output voltage b) FFT analysis

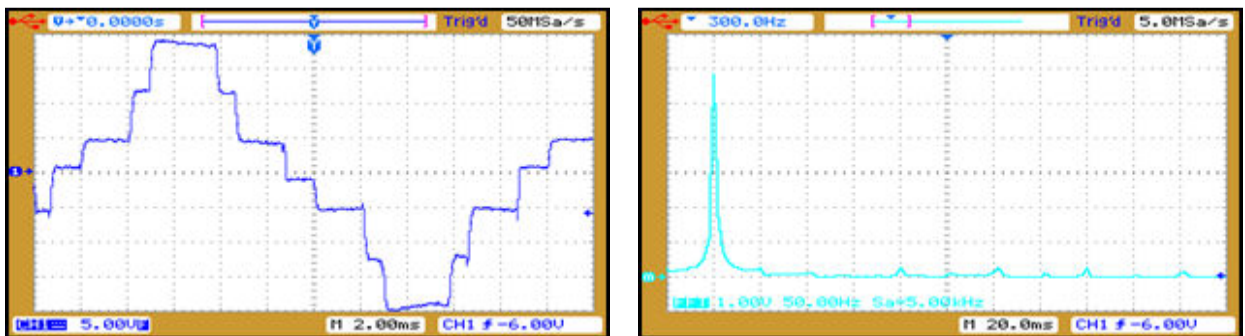

(a) (b)

Figure 15. Experimental results for $m=0.25$: a) output voltage b) FFT analysis

The match between simulation and experimental results validate the advantages and practicality of the proposed switching algorithm to cascaded converters.

5. CONCLUSION

In this paper, SHEPWM strategy has been used for a cascaded multilevel converter. Switching angels calculated by resultant theory and angels obtain from resultant theory trained to neural network as off-line,

neural network give the best switching angels for converter versus different modulation indexes as on-line. Also for a specific range of modulation index that resultant theory has not any solution, a DC-DC converter is used to overcome this problem. Also using the DC-DC converter causes the all levels of output voltage is produced in low modulation indexes and finally the THD of output voltage is improved in low modulation indexes. The simulation results carried out by SIMULINK/MATLAB show the well performance

of cascaded multilevel converter using proposed method.

REFERENCES

- [1] Lezana, P., Rodríguez, J., "Mixed Multicell Cascaded Multilevel Inverter", *IEEE International Symposium on Industrial Electronics*, 2007, pp. 509 – 514.
- [2] Naggar, K.E., Abdelhamid, T.H., "The selective harmonic elimination of new family of multilevel inverters using genetic algorithms", *Energy Convers Manage* 2008, pp.89–95.
- [3] Chiasson, J., Tolbert, L., McKenzie K, Du Z., "Real-time computer control of a multilevel converter using the mathematical theory of resultants", *J Math Comput Simul* 2003, pp.197–208.
- [4] S. H. Hosseini, A. Khoshkbar Sadigh and M. Sabahi, "New Configuration of Stacked Multicell Converter with Reduced Number Of DC Voltage Sources", PEMD2010.
- [5] J. N. Chiasson, L. M. Tolbert, K. J. McKenzie and Z. Du, "Control of a Multilevel Converter Using Resultant Theory", *IEEE Transactions On Control Systems Technology*, Vol. 11, No. 3, pp.345-354, May 2003
- [6] M. K. Bakhshizadeh, S. H. Askarian Abyaneh, J. Milimonfared, N. Farokhnia, "Selective Harmonic Elimination In Cascade Multilevel Inverter With Variable DC Source Using Artificial Neural Networks", *International Review Of Electrical Engineering*, vol. 6, no. 1, January-February 2011.
- [7] Kumpati, S. Narendra and Kannan Parthasarathy, "Identification and Control of Dynamical Systems Using Neural Networks", *IEEE Transactions on Neural Networks*, Vol. 1, No. 1, MARCH 1990.
- [8] D. Alejo, P. Maussion, J. Faucher, "Multiple model control of a Buck dc/dc converter", *Mathematics and Computers in Simulation*, Volume 63, Issues 3-5, PP: 249-260, 17 November 2003.