



SAKARYA ÜNİVERSİTESİ

FEN BİLİMLERİ ENSTİTÜSÜ DERGİSİ

Sakarya University Journal of Science
SAUJS

e-ISSN 2147-835X | Period Bimonthly | Founded: 1997 | Publisher Sakarya University |
<http://www.saujs.sakarya.edu.tr/en/>

Title: An Experimental Method for Estimating Combined Friction Torque in Vane Type
Pneumatic Semi Rotary Actuators

Authors: Mustafa DAĞDELEN, Mehmet İlteriş SARIGEÇİLİ

Received: 2019-12-05 10:00:07

Accepted: 2020-09-18 14:43:57

Article Type: Research Article

Volume: 24

Issue: 6

Month: December

Year: 2020

Pages: 1272-1283

How to cite

Mustafa DAĞDELEN, Mehmet İlteriş SARIGEÇİLİ; (2020), An Experimental Method for
Estimating Combined Friction Torque in Vane Type Pneumatic Semi Rotary

Actuators. Sakarya University Journal of Science, 24(6), 1272-1283, DOI:

<https://doi.org/10.16984/saufenbilder.652782>

Access link

<http://www.saujs.sakarya.edu.tr/en/pub/issue/57766/652782>

New submission to SAUJS

<http://dergipark.org.tr/en/journal/1115/submission/step/manuscript/new>

An Experimental Method for Estimating Combined Friction Torque in Vane Type Pneumatic Semi Rotary Actuators

Mustafa DAĞDELEN*¹, Mehmet İlteriş SARIGEÇİLİ²

Abstract

In this paper, an experimental method is proposed for estimation of friction torque in vane type pneumatic semi rotary actuators. The friction is modelled in the form of fully combined Stribeck model since this combined friction model provides good solutions for precise control applications. The study aims estimating static friction torque, Coulomb friction torque, Stribeck speed and viscous friction&damping coefficient which is included in fully combined Stribeck model for both counterclockwise and clockwise directions of the rotary actuator since these unknown parameters show differences when direction of motion is altered. For that purpose, an experimental setup is designed which includes pressure sensors for measuring the chamber pressures of actuator, analogue potentiometer for reading angular position as well as speed of vane and Arduino microcontroller card for data acquisition. A proper MATLAB Simulink block diagram is prepared for the simultaneous estimation of processed data from experimental data. Nonlinear curve fitting operation is applied and the unknown friction parameters are estimated on the fitted curve easily.

Keywords: Friction torque, Stribeck model, pneumatic semi rotary actuator, curve fitting

1. INTRODUCTION

Rotational motion needed in mechanical applications, especially in robotic platforms, is generally supplied by electrical motor actuators and hydraulic actuators due to their availability and convenience in control. However, these two actuators have high weight and high impedance. Especially, electrical motor actuators need high

transmission ratios to reach requested speed and torque levels which is limiting their back-drivability and reducing safety in contact. On the other side, pneumatic actuation systems are clean systems which use pressurized air as power source and can provide both linear and rotational motion for mechanical applications. These actuation systems can be used as an alternative to both hydraulic systems and commonly used

* Corresponding Author: mdagdeleenn@gmail.com

¹ Çukurova University, ORCID: <https://orcid.org/0000-0002-1448-104X>

² Çukurova University, E-Mail: msarigecili@gmail.com
ORCID: <https://orcid.org/0000-0002-9969-2005>

electrical motor actuators due to their outstanding properties such as high power to weight ratio, high compliancy, easy to maintain, wide range of force and speed arrangements without a transmission element [1]. Also, these remarkable actuators are favorable for harsh and spark-prohibited environments like mining factories, chemical working stations etc.

Pneumatics can provide rotational motions in two forms as full rotational motion and semi-rotational motion. Air motors which have several types as piston type, gear type, turbine type and vane type can deliver full rotational motion. However, semi rotary type actuators fit better where only limited rotational motion is needed at rotational joints. Semi rotary actuators can be in two different types as vane type and rack and pinion type. Vane type semi rotary pneumatic actuators work with the principle of vane rotating inside a chamber. Whereas, rack and pinion type semi-rotary actuators work with a linear cylinder functioning as a rack and pairing with a pinion for converting linear motion to rotational motion. This arrangement increases the size and weight of these actuators inherently and limits their usage areas. Hence, vane type semi rotary actuators in rotational joints become more advantageous. Even though pneumatic semi rotary actuators are well suited for rotational joints in robotics, these actuators have non-linear characteristics due to resisting friction, air compressibility and non-linear relationship between pressure and air flow rate. Any precise control of motion characteristics (i.e. angular position, velocity and acceleration) coupled with torque output requirement would necessitate the information of inertia characteristics (i.e. mass and mass moment of inertia) as well as friction force resisting to input torque. Hence, in this study, the friction models of semi rotary actuators will be estimated and their dynamics will be developed to utilize them efficiently.

Many friction force and torque models can be found in literature. Coulomb [2], combined Coulomb-Viscous [3], fully combined Stribeck [4] and LuGre model [5] are mostly preferred friction models in previous studies. In this study, we will focus on fully combined Stribeck model

since it includes satisfactory friction parameters which is sufficient for many pneumatic applications that operate generally in medium to high speeds. The Stribeck model includes the parameters of static friction torque (T_s), Coulomb friction torque (T_c), Stribeck speed (w_s) and viscous friction&damping coefficient (B). There exist other friction models in the literature which take into account pre-sliding regime in detail. However, this type of friction models is complex and more suitable for systems which operate in very low speed ranges. More information about these complex friction models can be found in [4]. In addition, there are many friction estimation studies for linear pneumatic cylinders [6,7,8] available in the literature. However, there exist very limited number of studies on friction in semi-rotary actuators.

The first friction study on rotary pneumatic actuators was performed by Belforte and Raparelli [9]. They tested three different actuators under different working pressures and provided the characteristics of static torque-pressure curves, adhesion torque curves, active and passive efficiency curves. Their designed experimental bench consisted of many electronic parts such as electric motor, torque sensor, pressure sensor making their setup complex and costly. Schlüter and Perondi [10] proposed a full mathematical model of semi-rotary actuators including friction in the form of LuGre model. The friction torque-angular speed map was constructed and the parameters of LuGre friction model were found by curve fitting operations. Then, Schlüter and Perondi [11] tested their model on a SCRARA robot with semi-rotary actuator. On the other studies about rotary pneumatic actuator, the researchers focused mainly on the mathematical model of pneumatic actuators and valves where the detailed information about friction were not available. A general mathematical model for vane type air motors were developed by Luo et al. [12] by describing the mechanical structure of rotary actuators and their working principles very well. However, there is only assumptions about friction torque in their study. In another study, Sorli et al. [13] provided a general mathematical model for both linear and rotary pneumatic actuators. They assumed friction torque as constant in their study.

But, constant friction torque cannot be accepted for precise control applications of pneumatic rotary actuators. Lan and Cheng [14] provided modelling and design of air vane motors to reduce ripples in torque by proposing a non-circular profile of stator to eliminate the variations in angular speed and torque. Their study did not include actuator vane friction. Zhang et al. [15] applied servo position control in rack and pinion type semi-rotary pneumatic actuators and they claimed that position instabilities had been observed because of ignored friction torque models.

The unavailable information on friction torque characteristics of vane type pneumatic semi rotary actuators prohibit wide application of these actuators. Therefore, in this study, an experimental method is proposed for quick estimation of resisting friction torque in this type of pneumatic actuators.

In the paper, the mechanical structure and mathematical models will be discussed in Section 2. In Section 3, experimental setup and measurement techniques will be demonstrated. The proposed method will be presented in detail in Section 4. Section 5 will provide the experimental results. Lastly, the conclusion and discussion will be provided in Section 6.

2. MECHANICAL STRUCTURE AND MATHEMATICAL MODELS OF SEMI ROTARY ACTUATORS

The general cross-sectional view of a semi rotary actuator is shown in Fig.1. This type of actuators is permitted to oscillate between two angles i.e. the higher (θ_H) and lower (θ_L) oscillation angles, respectively, whereas θ_M is the half-stroke angle of the actuator. Then, the range of motion would be calculated from ($\theta_H - \theta_L$). The stationary body is called as stator and placed on a ground whereas the rotor unit rotate inside the stator unit. The rotor unit includes the combination of two separate parts as rotating shaft and vane as shown in detail in Fig.2.

Semi-rotary actuators can rotate either in counter clockwise (CCW) or clockwise (CW) direction

according to the pressurized chamber (A or B in Fig.1). To rotate the actuator in CCW direction, the air is filled to the chamber A through port A with a certain mass flow rate \dot{m}_A . The pressure is increased in the chamber and this increased pressure P_A acts on the vane surface area generating a torque that tends to rotate the rotor unit in CCW direction. During CCW movement, the air inside the chamber B is exhausted to the atmosphere through directional control valve (DCV). To move the actuator in CW direction, the air is filled to the chamber B through port B with a certain mass flow rate \dot{m}_B and the resulting pressure P_B drives the rotor unit in CW direction while air in the chamber A is exhausted.

The torque produced by pressurized air about point O (Fig.1) is calculated by multiplying the net pressure force acting on the vane and the distance from point O to the acting point of this force. The net pressure force is the multiplication of the pressure difference in the two chambers and the net vane area. From the vane and rotating shaft structure shown in Fig.2., D is the rotating shaft diameter, H is the vane surface height and W is the vane surface width. Hence, the vane surface area denoted by A_v is calculated by $H * W$. Since the net pressure force is assumed as acting on the center of the vane surface area which is vane torque centerline (Fig.2), r is $(H + D)/2$.

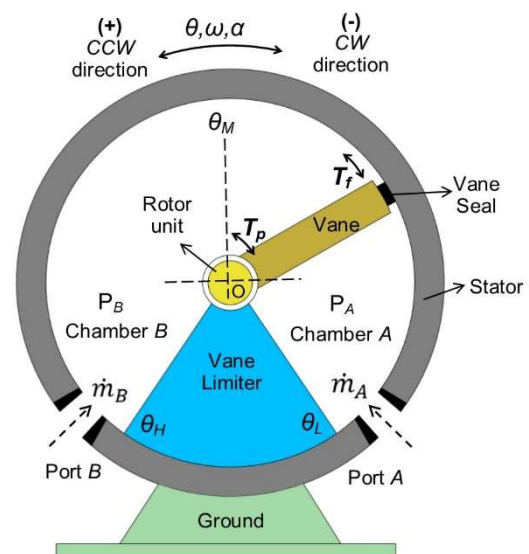

Figure 1 The cross-section of semi rotary pneumatic actuators

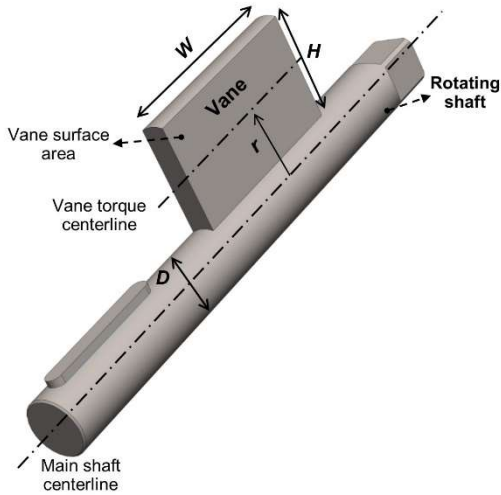

Figure 2 Rotor unit

The net produced torque of the actuator is defined from Euler equation (Eq.1) where T_p , T_f , T_L , I and α represent pneumatic torque produced from the pressure difference in chambers, friction torque that is to be estimated with the proposed method, payload torque, mass moment of inertia of the rotating parts of the actuator and angular acceleration, respectively.

$$T_{net} = T_p - T_f - T_L = I * \alpha \quad (1)$$

In the proposed study, experiments are carried out at constant angular speed where angular acceleration becomes zero ($\alpha = 0$) and also there is no payload in experiments ($T_L = 0$). Therefore, in experiments, the pneumatic torque (T_p) will be equal to the friction torque (T_f) as shown in Eq.2.

$$T_p = (P_A - P_B) * A_v * r = T_f \quad (2)$$

The main cause of friction torque originates at the contact surface between vane seal and the rotor internal surface (Figs.1 and 2). In reality, there exist other friction torques in the actuator such as friction in shaft bearings and coaxially attached position sensors (potentiometer, encoder etc.) to the actuator shaft. However, this type of friction forces is very small compared to the friction force caused by vane seal. Therefore, they are assumed negligible for the purpose of this study.

The full Stribeck friction model formed for both motion directions of actuator is shown in Fig.3. Positive values correspond to the CCW direction parameters, whereas negative values (except B)

correspond to the CW friction torque parameters. The change in friction torque with respect to angular speed can be seen in Fig.3. The mathematical model of the Stribeck friction model is given in Eq.3 [10]. In this equation, T_s and T_c correspond to the static friction torque and Coulomb friction torque, respectively. The Stribeck effect is observed in the low speed ranges. w_s is the Stribeck speed where beyond this point, friction torque starts to behave linearly with increasing speed. B is the viscous friction&damping coefficient and j corresponds to a constant which determines the level of Stribeck effect. For linear pneumatic cylinders, this constant can take values between 0.5-2 which is also accepted for rotary pneumatic actuators in [10].

$$T_f = T_c + (T_s - T_c) * e^{-\left(\frac{w}{w_s}\right)^j} + B * w \quad (3)$$

By recalling that the pneumatic torque (T_p) from Eq.2 will be equal to the friction torque (T_f) from Eq.3 then Eq.4 can be written as:

$$(P_A - P_B) * A_v * r = T_c + (T_s - T_c) * e^{-\left(\frac{w}{w_s}\right)^j} + B * w \quad (4)$$

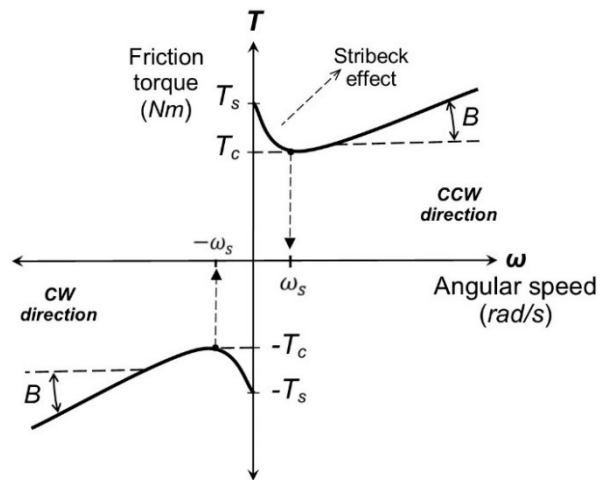

Figure 3 Stribeck friction torque model

3. EXPERIMENTAL SETUP

Full experimental setup in the proposed methodology includes two subsystems: rotary pneumatic system and measurement system. The pneumatic system is shown in Fig.4 and it consists of an air compressor, an air tank, a filter-

regulation-lubrication (FRL) unit, a manually adjustable pressure control valve (APV), a 5/3 closed center solenoid directional control valve (DCV), two one-way flow control valves (FCV) and a semi rotary actuator which has 270° range of motion (ROM). S_A and S_B represents the solenoids of the DCV. When one of these solenoids is energized, the air is sent to the corresponding chamber (i.e. chamber A or B) and the semi-rotary actuator rotates either in CCW or CW direction based on its working principle.

Measurement system setup responsible from data receiving and recording consists of a data acquisition and control card, two analogue output pressure sensors to read the chamber pressures, an analogue output rotary position sensor for angular position and speed, a two-way relay card and a PC as schematized in Fig.5. The working principle of the system is as follows: when one of the movement buttons is pressed, the control card produces a triggering signal for relay card (u_a, u_b) and the relay card switches the electric power which is coming from the power supply for the solenoids of directional control valve (S_A, S_B). Then, during motion, the pressures in chambers (P_A, P_B) as well as angular position and speed (θ, ω) values are measured via the sensors. The sensor measurements are carried out by Arduino Software Package environment existing in MATLAB Simulink. For this purpose, a proper block diagram is constructed by the help of this package (Fig.6). In this figure, blocks of “Pin 1”, “Pin 2” and “Pin 3” represent the pressure signal from sensors at chambers A and B, and angular position signal from rotary potentiometer outputted by Arduino micro control card, respectively. These three sensors produce analog signals between 0-5V. Therefore, in order to get meaningful data from each sensor, separate calibrations were made. Therefore, P_A and P_B coming out of the signal calibrations (Fig.6) corresponds to the pressure in the actuator chambers in “Pascal” unit, while θ parameter represents the angle in “degree” unit. In order to read angular velocity, the first order derivative of the position is taken. In order to calculate the torque, the difference of the pressures is taken

with a help of the difference block and multiplied by the constant that will convert the pressure value to torque, and as a result, the net torque is obtained. On the other hand, in order to express the angular velocity in terms of “rad/s”, it is multiplied by the constant that will make the “degree” to “radian” conversion and the angular velocity is recorded in “rad/s”. The equipment used in this experimental setup and their specifications are tabulated in Table 1 and complete experimental setup is also shown in Fig.7.

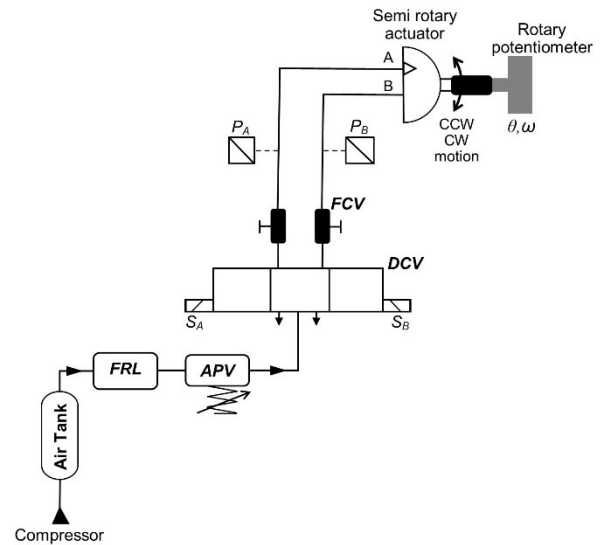

Figure 4 Pneumatic system setup

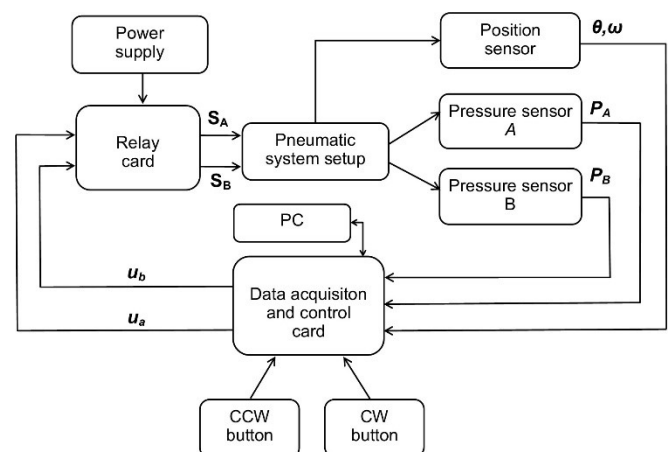

Figure 5 Measurement system setup

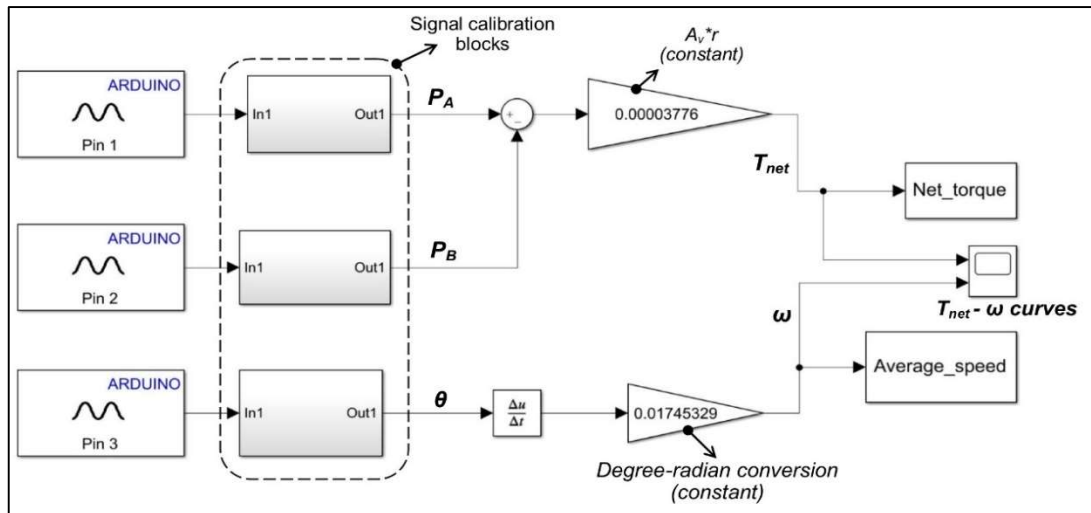

Figure 6 MATLAB Simulink block diagram

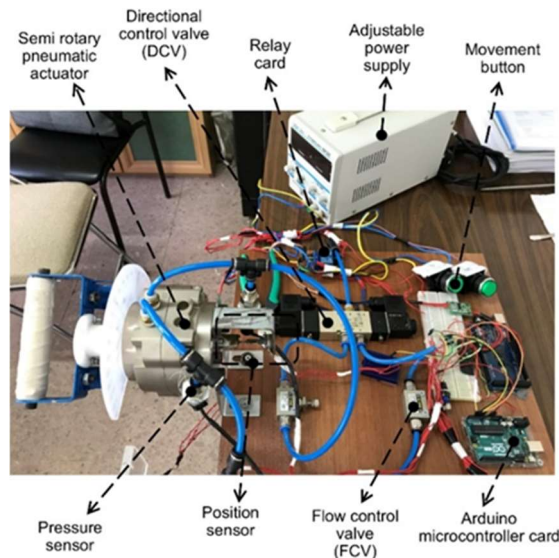

Figure 7 Complete experimental setup

4. PROPOSED METHOD

4.1. Estimation of Static Friction Torque (T_s)-Part 1

In the first part of the experimental method, static friction torque (T_s) corresponding to the maximum friction value for impending motion is estimated (Fig.3). Therefore, static friction torque (T_s) is estimated from Eq.4 by setting $w=0$ and following the steps described below:

1. Set supply pressure (P_s) to zero gage pressure from adjustable flow control valve.
2. Fully open flow control valves.
3. Press CCW movement button.
4. Turn gradually pressure control valve until the actuator just starts to move.
5. At the instant of motion initialization deactivate the CCW button and stop actuator movement.
6. Get the highest friction torque value from MATLAB graphs and record the data.

7. Repeat these procedures 24 times to complete the experiment.
8. Tabulate the results and take the average of 24 values.

The steps listed above is applied to find the static friction torque of CCW direction. To find CW static friction torque, the same procedures are applied except that the CW button is pressed in step 3 and CW button is deactivated in step 5.

Table 1
Equipment used in experimental setup and their specifications

Experimental setup and their specifications		
Rotary pneumatic actuator	Vane type	Single vane
	Shaft type	Double ended
	Range of motion (ROM)	270 °
	Dimensions	$D=0.017\text{ m};$ $H=0.02988\text{ m};$ $W=0.054\text{ m};$ $A_v=0.00161352\text{ m}^2;$ $r=0.0234\text{ m}$
Directional control valve	Type	5/3 closed center
	Operating voltage	12 VDC
Position sensor	Type	Rotary potentiometer
	Output range	0-5 VDC analogue
Pressure sensors	Measurement range	0-1.2 MPa
	Output range	0-5 VDC analogue
Pressure regulating valve	Working type	Manually adjustable
	Max. input pressure	16 bar
	Output pressure range	0.5-10 bar
Data acquisition and control card	Arduino Uno	
PC	64bit ; 2400 CPU; 3.10Ghz processor	

4.2. Estimation of Coulomb Friction Torque, Stribeck Speed, Viscous Friction&Damping Coefficient and Stribeck Coefficient (T_c, w_s, B and j)- Part 2

In the second part of the experimental method, after the estimation of static friction torque, other friction torque parameters (B, T_c, w_s and j) are

found by consecutive experiments at distinct angular speeds (w). The following steps should be carried out to estimate these four friction torque parameters.

1. Set supply pressure to $P_s = 5\text{ bar}$ from pressure regulating valve.
2. Fully open the flow control valves.
3. Adjust CCW flow control valve to get a certain angular speed.
4. Press CCW movement button and move the actuator at a specified speed.
5. At the end of the motion, deactivate the button and free pneumatic actuator.
6. Record the pressure data and angular speed.
7. Calculate net friction torque on vane.
8. Set back actuator position to the initial experimental position.
9. Repeat the procedure from 1-8 for 15 times on the actuator.
10. Apply nonlinear curve fitting to these 15 friction torque-angular speed data to find T_c, w_s, B and j paramaters.

In order to find T_c, w_s, B and j for CW direction, the same procedure is followed except at step 3 CW flow control valve is adjusted and at step 4 CW movement button is pressed.

5. EXPERIMENTAL RESULTS

In this section, experiments are carried out on the semi-rotary actuator (Table 1) for both movement directions. According to the proposed methodology, the first part is the estimation of the static friction torque. Hence, the experimental procedures are applied to the tested actuator and the results are tabulated in Table 2 for both CCW and CW movement directions.

As presented in Table 2, the results are very convergent in each experiment. As a result of this part, the average static fiction torque values for CCW and CW directions are obtained as 1.637 Nm and -1.564 Nm respectively. As an example, the process of obtaining static friction torque from the tested actuator is shown in Fig.8. In Fig.8, the push button is pressed at the instant $t=0s$ even though the figure only represents the time interval $t=15s$ to $t=25s$. Between the points “a.” and “b.”,

there is no pressure applied because the pressure is adjusted from pressure regulating valve during this period. However, as the pressure is started to be increasing gradually, the first motion is observed at point “b.”. Between points “b.” and “c.”, the pressure is increased very fast. When it reaches the point “c.”, the actuator starts motion and the friction value is reduced inherently. In each experiment, the maximum point of friction torque “c.” is recorded and tabulated.

Table 2
Static friction torque measurements- Part 1

Experiment #	T_s for CCW direction (Nm)	T_s for CW direction (Nm)
1	1.668	-1.570
2	1.556	-1.514
3	1.723	-1.458
4	1.612	-1.569
5	1.667	-1.513
6	1.556	-1.514
7	1.779	-1.626
8	1.667	-1.402
9	1.667	-1.514
10	1.500	-1.514
11	1.612	-1.569
12	1.444	-1.680
13	1.556	-1.625
14	1.612	-1.570
15	1.612	-1.681
16	1.723	-1.681
17	1.724	-1.736
18	1.668	-1.458
19	1.668	-1.570
20	1.780	-1.514
21	1.724	-1.570
22	1.556	-1.570
23	1.612	-1.514
24	1.612	-1.625
Average	1.637	-1.564

The procedures of the second part are applied to the tested actuator after the estimation of static friction torque (T_s). The obtained net friction torque (T_f) and angular speed (w) values are tabulated in Table 3.

As an example, the process of obtaining net friction torque and angular speed readings are shown in Figs. 9 and 10, respectively. In these figures, the point “b.” represents the instant that

movement button is pressed. Between points “b.” and “c.”, there is a small delay naturally existing in pneumatic systems. The actuator moves between points “c.” and “d.”, and the results are extracted between this time interval. The point “d.” represents the end of the actuator’s stroke and the button is deactivated at this point. There is a sudden jump at the calculated friction torque value from points “d.” to “e.” until the equilibrium is satisfied due to the response time. On the other side, angular speed measurements (Fig.10) have noisier signal than pressure measurements due to the numerical derivation of angular position data. Hence, average friction torque and average angular speed value are calculated between points “c.” and “d.” and listed in Table 3.

Table 3
Angular speed and net friction torque measurements- Part 2

Exp. #	CCW direction		CW direction	
	w (rad/s)	T_f (Nm)	w (rad/s)	T_f (Nm)
1	0.802	1.637	-0.379	-1.120
2	2.840	1.203	-1.012	-1.326
3	3.138	1.317	-2.044	-1.430
4	3.930	1.374	-2.661	-1.562
5	4.252	1.448	-3.353	-1.667
6	4.665	1.467	-4.105	-1.521
7	4.753	1.517	-4.208	-1.794
8	5.367	1.610	-4.962	-1.696
9	5.745	1.703	-5.405	-1.785
10	5.846	1.665	-6.923	-1.895
11	6.787	1.857	-7.046	-2.053
12	6.879	1.847	-7.459	-2.143
13	7.464	1.952	-7.671	-2.039
14	8.843	2.208	-7.999	-2.213
15	9.005	2.391	-9.274	-2.257

After application of procedures in Parts 1 and 2 to the tested rotary actuator, nonlinear curve fitting operations are applied to the experimental data of both CCW and CW directions. In the result of the successful curve fitting operations, Stribeck friction torque models (Eqs. 5 and 6) are determined as in Figs. 11 and 12.

$$(T_f)_{CCW} = 0.691 + 0.946 * e^{-\left(\frac{w}{0.995}\right)^{2.016}} + 0.174 * w \quad (5)$$

$$(T_f)_{CW} = -1.170 - 0.394 * e^{-\left(\frac{w}{-0.074}\right)^{3.060}} + 0.120 * w \quad (6)$$

The Stribeck friction model parameters are also estimated automatically and given in Table 4. The goodness of fit value in the form of sum of squared errors (SSE) for curve fitting operation for CCW and CW directions are 0.0315 and 0.0937, respectively.

Table 4

Estimated friction model parameters

Stribeck model parameters	CCW direction	CW direction
T_s (Nm)	1.637	-1.564
T_c (Nm)	0.691	-1.170
w_s (rad/s)	0.995	-0.074
B (Nsm/rad)	0.174	0.120
j	2.016	3.060

6. DISCUSSION AND CONCLUSION

In this study, an experimental setup and methodology are developed for friction torque estimation of vane type semi rotary pneumatic actuators. For experimental setup, only two pressure sensors and one rotary potentiometer are used to evaluate the friction torque parameters. The chamber pressures (P_A, P_B) and angular speed (w) data is gathered using Arduino

microcontroller card with MATLAB Simulink software. The tested actuator is examined at angular speeds between $w = 0 - 10 \text{ rad/s}$ since the curves will continue to behave linear for speeds higher than Stribeck speed (w_s) (Figs. 11-12). The supply pressure is set to 5 bar in the experiments, because pneumatic working pressure is generally between $4 - 6 \text{ bars}$ in literature. The data collected are curve fitted and friction torque parameters are estimated easily for both directions of actuator. In most of the studies, the friction torque models assumed as the same for both CCW and CW directions. However, it has been presented in this study that the friction torque characteristics change when the direction of motion is changed. In conclusion, both friction torque curves and Stribeck friction torque models are provided as a function of angular speed in the proposed methodology. It has been also shown that the friction torque resisted by rotary actuator does not behave linearly at lower speeds. Even though, Stribeck coefficient (j) is assumed generally as 2 in previous studies, it has been realized that it differs for both of the movement directions and can take the values higher than 2. Furthermore, the obtained Stribeck friction torque model can be used at the precise control applications of vane type semi rotary pneumatic actuators.

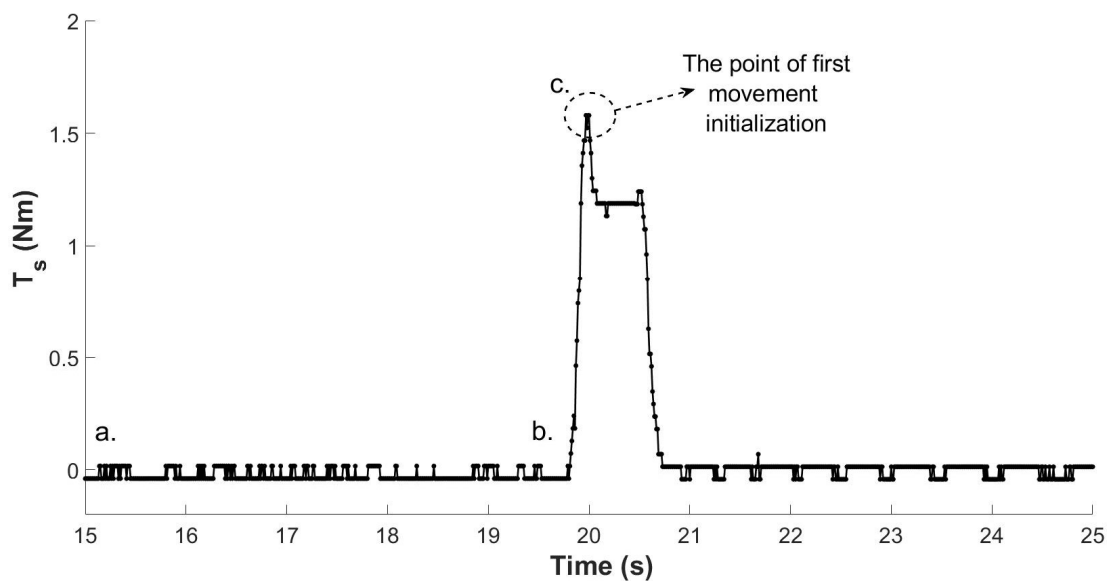

Figure 8 Static friction torque measurement graph- Part 1

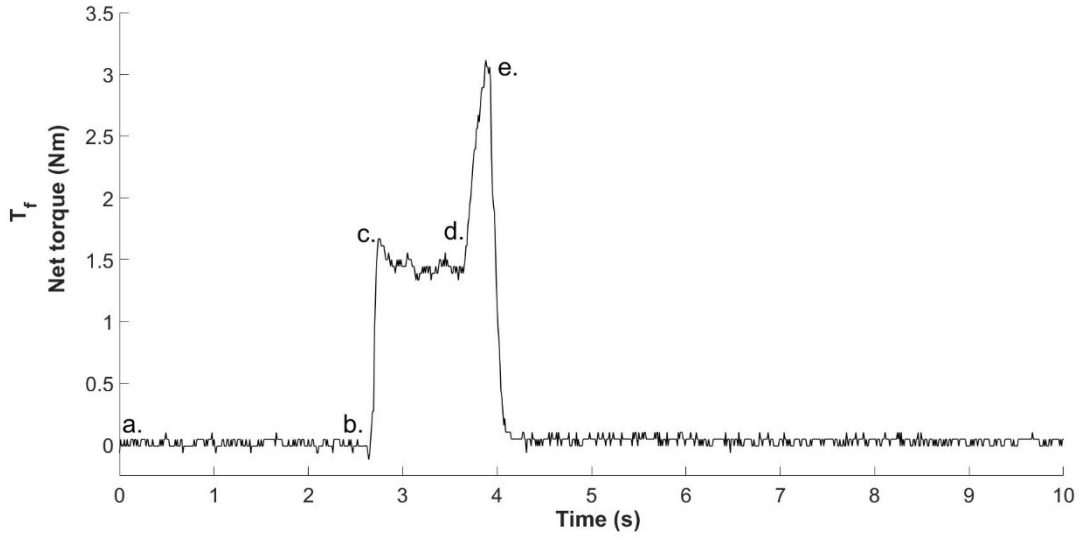

Figure 9 An example net friction torque reading- Part 2

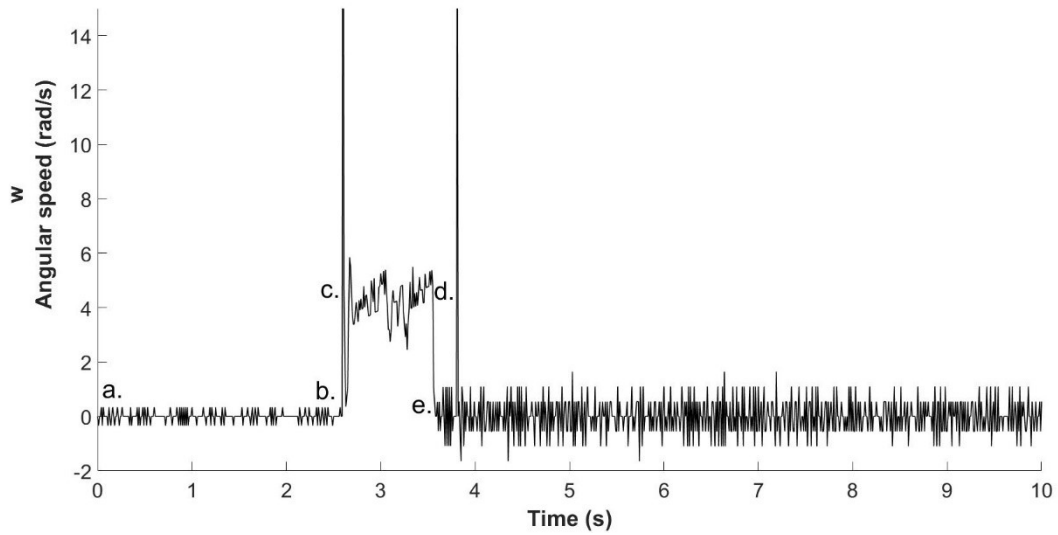

Figure 10 An example angular speed reading- Part 2

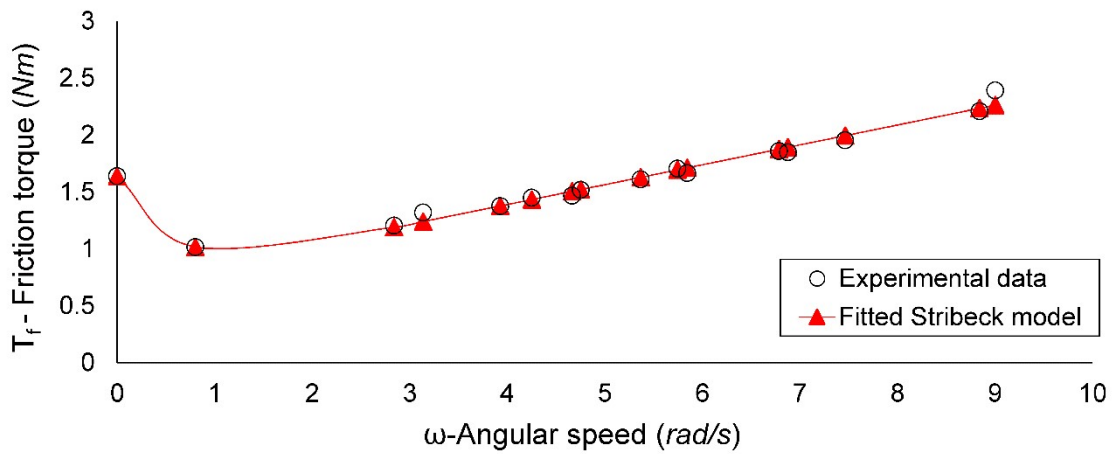

Figure 11 Stribeck friction torque model for CCW direction

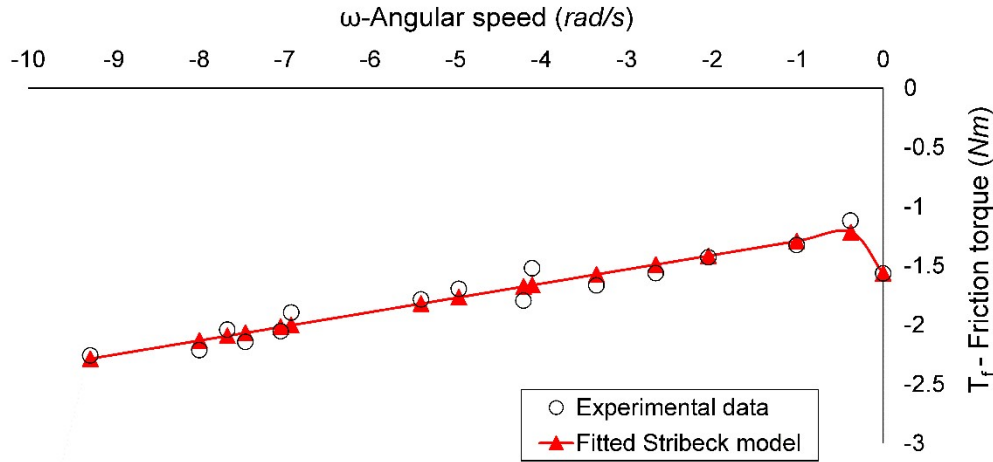

Figure 12 Stribeck friction torque model for CW direction

Acknowledgement

The authors would like to thank the reviewers for all useful and instructive comments on the paper.

Funding

This study was funded by Çukurova University-ÖYP coordination.

The Declaration of Conflict of Interest/ Common Interest

The authors do not have any conflict of interest or common interest with any institution or person that they know that could affect their work.

Authors' Contribution

MD: Literature review, research, methodology, simulation, writing the initial draft.

MİS: Supervision, research, methodology, interpretation, writing-revision, and finalizing.

The Declaration of Ethics Committee Approval

The authors declare that this work does not require an ethics committee approval or any special permission.

The Declaration of Research and Publication Ethics

The authors of the paper declare that they comply with the scientific, ethical and quotation rules of SAUJS in all processes of the paper and that they do not make any falsification on the data collected. In addition, they declare that Sakarya University Journal of Science and its editorial board have no responsibility for any ethical violations that may be encountered, and that this study has not been evaluated in any academic publication environment other than Sakarya University Journal of Science.

REFERENCES

- [1] E. Richer and Y. Hurmuzlu, "A High Performance Pneumatic Force Actuator System: Part I—Nonlinear Mathematical Model," *Journal of Dynamic Systems, Measurement, and Control*, vol. 122, no. 3, pp. 416–425, 1999.
- [2] A. Harnoy and B. Friedland, "Modelling and Measuring Friction Effects," *IEEE Control Systems*, pp. 82-91, 2008.
- [3] H. Olsson, K. Åström, C. C. D. Wit, M. Gäfvert, and P. Lischinsky, "Friction Models and Friction Compensation," *European Journal of Control*, vol. 4, no. 3, pp. 176–195, 1998.

- [4] Y. F. Liu, J. Li, Z. M. Zhang, X. H. Hu, and W. J. Zhang, "Experimental Comparison of Five Friction Models on the Same Test-Bed of the Micro Stick-Slip Motion System," *Mechanical Sciences*, vol. 6, no. 1, pp. 15–28, 2015.
- [5] C. C. D. Wit, H. Olsson, K. Astrom, and P. Lischinsky, "A new model for control of systems with friction," *IEEE Transactions on Automatic Control*, vol. 40, no. 3, pp. 419–425, 1995.
- [6] G. Belforte, G. Mattiazzo, S. Mauro, and L. R. Tokashiki, "Measurement of friction force in pneumatic cylinders," *Tribotest*, vol. 10, no. 1, pp. 33–48, 2003.
- [7] P.L.Andrighetto, A.C.Valdiero and L.Carlotto, "Study of the Friction Behavior in Industrial Pneumatic Actuators," *ABCM Symposium Series in Mechatronics*, vol. 2, pp. 369-376, 2006.
- [8] H.Kosari, S.A.A.Moosavian, "Friction Compensation in a Pneumatic Actuator Using Recursive Least Square Algorithm," *5th Australian Control Conference (AUCC)*, Australia, pp. 81-86, 2015.
- [9] G. Belforte and T. Raparelli, "Friction Analysis of Pneumatic Semi-Rotary Actuators," *Tribology Transactions*, vol. 40, no. 1, pp. 57–62, 1997.
- [10] M. S. Schlüter and E. A. Perondi, "Mathematical Modeling of Pneumatic Semi-Rotary Actuator with Friction," *Journal of the Brazilian Society of Mechanical Sciences and Engineering*, vol. 40, no. 11, 2018.
- [11] M. S. Schlüter and E. A. Perondi, "Mathematical Modelling with Friction of a SCARA Robot Driven by Pneumatic Semi-Rotary Actuators," *IEEE Latin America Transactions*, vol.18, no. 6, pp. 1066-1076, 2020.
- [12] X. Luo, J.Wang, L.Shpanian, N.Jia, G.Liu, A.S.I. Zinober, "Development of a Mathematical Model for Vane Type Air Motors with Arbitrary N Vanes," *Proceedings of the World Congress on Engineering (WCE 2008)*, London, 2008.
- [13] M. Sorli, L. Gastaldi, E. Codina, and S. D. L. Heras, "Dynamic Analysis of Pneumatic Actuators," *Simulation Practice and Theory*, vol. 7, no. 5-6, pp. 589–602, 1999.
- [14] C.-C. Lan and C.-W. Cheng, "Modeling and design of air vane motors for minimal torque ripples," *2010 IEEE/ASME International Conference on Advanced Intelligent Mechatronics*, 2010.
- [15] Y. Zhang, K. Li, S.Weï and G. Wang, "Pneumatic rotary actuator position servo system based on ADE-PD control," *Applied Sciences*, vol. 8, no. 406, 2018.