



Available online at [www.academicpaper.org](http://www.academicpaper.org)

**Academic @ Paper**

ISSN 2146-9067

International Journal of Automotive  
Engineering and Technologies

Vol. 4, Issue 3, pp. 118 – 129, 2015

**Original Research Article**

---

**International Journal of Automotive  
Engineering and Technologies**

---

<http://www.academicpaper.org/index.php/IJAET>

## **The Automotive Engine Modeling for Steady-State Condition Using FORTRAN/GT-POWER**

Brahim Menacer<sup>1\*</sup>, Mostefa Bouchetara<sup>1</sup>

<sup>1</sup> Department of Mechanical Engineering, University of Sciences and the Technology of Oran, 31000 Algeria

Received 01 October 2014 Accepted 25 August 2015

---

### **Abstract**

The increasing complexity of modern engines has rendered the prototyping phase long and expensive. This is where engine modelling becomes in the recent years extremely useful and can be used as an indispensable tool when developing new engine concepts. The purpose of this work was to provide a flexible thermodynamic model based on the filling-and-emptying approach for the performance prediction of a four-stroke turbocharged compression ignition engine. To validate the model, comparisons were made between results from a computer program developed using FORTRAN language and the commercial GT-Power software operating under different conditions. The comparisons showed that there was a good concurrence between the developed program and the commercial GT-Power software. The range of variation of the rotational speed of the diesel engine chosen extends from 800 to 2100 RPM. By analysing these parameters with regard to two optimal points in the engine, one relative to maximum power and another to maximum efficiency, it was found that if the injection timing is advanced, the maximum levels of pressure and temperature in the cylinder are high.

**Key words:** Single-zone model, ignition compression engine, heat transfer, friction, turbocharged diesel engine, GT-Power, performance optimization.

---

\*Corresponding Author:

Email: [acer.msn@hotmail.fr](mailto:acer.msn@hotmail.fr)

---

## 1. Introduction

More than one century after his invention by Dr. Rudolf Diesel, the compression ignition engine remains the most efficient internal combustion engines for ground vehicle applications. Thermodynamic models (zero-dimensional) and dimensional models (uni-dimensional and multi-dimensional) are the two types of models that have been used in internal combustion engine simulation modelling. Nowadays, trends in combustion engine simulations are towards the development of comprehensive dimensional models that accurately describe the performance of engines at a very high level of details. However, these models need a precise experimental input and substantial computational power, which make the process significantly complicated and time-consuming [1]. On the other hand, zero-dimensional models, which are mainly based on energy conservation (first law of thermodynamics) are used in this work due to their simplicity and of being less time-consuming in the program execution, and their relatively accurate results [2]. There are many modelling approaches to analysis and optimize of the internal combustion engine. Angulo-Brown et al. [1] optimized the power of the Otto and Diesel engines with friction loss and finite duration cycle. Chen et al. [2] derived the relationships of correlation between net power output and the efficiency for Diesel and Otto cycles; there are thermal losses only on the transformations in contact with the sources and the heat sinks other than isentropic. Chen et al. [2] proposed a model for which the thermal loss is represented more classically in the form of a thermal conductance between the mean temperature of gases, on each transformation = constant, = constant, compared to the wall temperature. Among the objectives of this work is to conduct a comparative study of simulation results of the performances of a six cylinder direct injection turbocharged compression ignition engine obtained with the elaborate calculation code in FORTRAN and those with the software GT-Power. We also studied the influence of certain

important thermodynamic and geometric engine parameters on the brake power, on the effective efficiency, and also on pressure and temperature of the gases in the combustion chamber.

## 2. Diesel Engine Modeling

There are three essential steps in the mathematical modelling of internal combustion engine [3, 4]:

(1) Thermodynamic models based on first and second law analysis, they are used since 1950 to help engine design or turbocharger matching and to enhance engine processes understanding; (2) Empirical models based on input-output relations introduced in early 1970s for primary control investigation; (3) Nonlinear models physically-based for both engine simulation and control design. Engine modelling for control tasks involves researchers from different fields, mainly, control and physics. As a consequence, several specific nominations may designate the same class of model in accordance with the framework. To avoid any misunderstanding, we classify models within three categories with terminology adapted to each field:

1. Thermodynamic-based models or knowledge models (so-called white box) for nonlinear model physically-based suitable for control.
2. Non-thermodynamic models or "black-box" models for experimental input-output models.
3. Semiphysical approximate models or parametric models (so-called "grey-box"). It is an intermediate category, here, models are built with equations derived from physical laws of which parameters (masses, volume, inertia, etc.) are measured or estimated using identification techniques.

Next section focuses on category 1 with greater interest on thermodynamic models. For the second and third class of models, see [5].

### 2.1 Thermodynamic based engine model

Thermodynamic modeling techniques can be divided, in order of complexity, in the following groups [5]: (a) quasi-stable (b)

filling and emptying and (c) the method of characteristics (gas dynamic models). Models that can be adapted to meet one or more requirements for the development of control systems are: quasi-steady, filling and emptying, cylinder-to-cylinder (CCEM) and mean value models (MVEM). Basic classification of thermodynamic models and the emergence of appropriate models for control are shown in Figure 1.

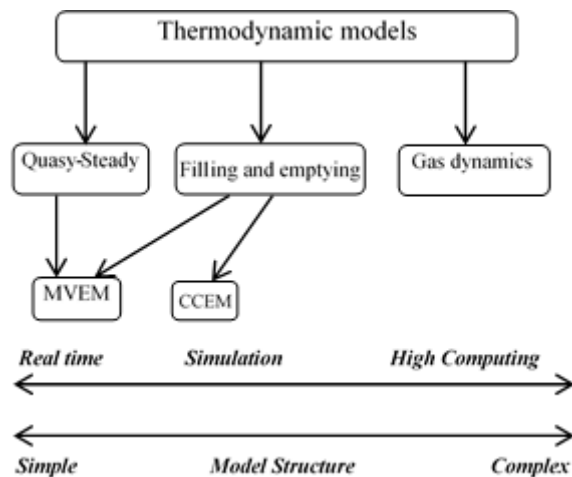

Fig.1: Basic classification of thermodynamic models of internal combustion engines

### 2.1.1. Quasi-steady method

The quasi-steady model includes crankshaft and the turbocharger dynamics and empirical relations representing the engine thermodynamic [6]. Quasi-steady models are simple and have the advantage of short run times. For this reason, they are suitable for real-time simulation. Among the disadvantages of this model was the strong dependence of the experimental data and the low accuracy. Thus, the quasi-steady method is used in the combustion subsystem with mean value engine models to reduce computing time.

### 2.1.2. Filling and emptying method

Under the filling and emptying concept, the engine is treated as a series of interconnected control volumes (open thermodynamic volume) [7, 8]. Energy and mass conservation equations are applied to every open system with the assumption of uniform state of gas. The main motivation for filling and emptying technique is to give general

engine models with the minimum requirement of empirical data (maps of turbine and compressor supplied by the manufacturer). In this way, the model can be adapted to other types of engines with minimal effort. Filling and emptying model shows good prediction of engine performance under steady state and transient conditions and provides information about parameters known to affect pollutant or noise. However, assumptions of uniform state of gas cover up complex acoustic phenomena (resonance).

### 2.1.3. Method of characteristics (or gas dynamic models)

It is a very powerful method to accurately access parameters such as the equivalence ratio or the contribution to the overall noise sound level of the intake and the exhaust manifold. Its advantage is effectively understood the mechanism of the phenomena that happen in a manifold [9] and, allows to obtain accurately laws of evolution of pressure, speed and temperature manifolds at any point, depending on the time, but the characteristic method requires a much more important calculation program, and the program's complexity increases widely with the number of singularities to be treated.

## 3. General Equation of the Model

In this work, we developed a zero-dimensional model based on that proposed by [8], that gives satisfactory combustion heat and which determines the main thermodynamic parameters. In this model, it is assumed that: engine plenums (cylinders, intake and exhaust manifolds) are modelled as separate thermodynamic systems containing gases at uniform state. The pressure, temperature and composition of the cylinder charge are uniform at each time step, which is to say that no distinction is made between burned and unburned gas during the combustion phase inside the cylinder. With respect to the filling-and-emptying method, mass, temperature and pressure of gas are calculated using first law and mass conservation. Ideal gases with constant specific heats, effects of heat transfer through

intake and exhaust manifolds are neglected; compressor inlet and turbocharger outlet temperatures and pressures are assumed to be equal to ambient pressure and temperature. From the results of Semin et al. [10]; temperatures of the cylinder head, cylinder walls and piston crown are assigned constant values. The crank speed is uniform (steady-state engine). The rate of change of the volume with respect to time is given as follows, Figure 2:

$$V_{cyl}(t) = V_{clear} + \frac{\pi D^2 L}{4} (1 + \beta_{mb} (1 - \cos(\omega t)) - \sqrt{1 - \beta_{mb}^2 \sin^2(\omega t)}) \quad (1)$$

$t$  is the time corresponding to crank angle measured with respect to the top dead center (s),  $\omega$  is the engine speed (rad/s),  $V_{clear}$  is the Clearance volume ( $V_{clear} = \frac{V_{cyl}(t)}{c_r}$ ),  $c_r$  is the compression ratio,  $\beta_{mb} = \frac{2l}{L}$  is the ratio of connected rod length to crank radius,  $l$  is the connecting rod length (m),  $L$  is the piston stroke [m] and  $D$  is the cylinder bore (m).

The piston speed  $v_{pis}$  (m/s) is equal to:

$$v_{pis} = \frac{4}{\pi D^2} \left. \frac{dV_{cyl}(t)}{dt} \right|_t \quad (2)$$

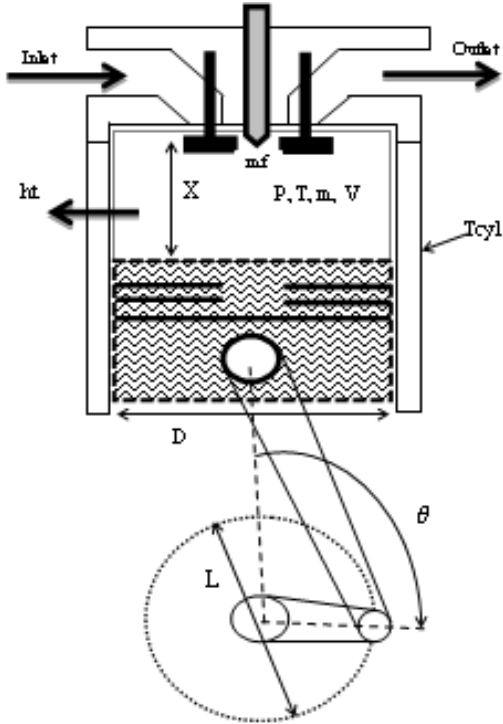

Fig.2: Cylinder scheme and its variables (p: pressure; T: temperature; m: mass and V: volume).

### 3.1 Mass entering the cylinder

The conservation equation of the mass applied to the cylinder is:

$$\frac{dm_{cyl}}{dt} = \dot{m}_f + \dot{m}_{in} - \dot{m}_{out} \quad (3)$$

### 3.2 Ideal Gas

The ideal gas model gives the relationship between the mass  $m_{cyl}$  in the cylinder, the volume  $V_{cyl}$ , the pressure  $p_{cyl}$  and temperature  $T_{cyl}$  [11]:

$$\frac{dT_{cyl}}{dt} = \frac{1}{m_{cyl} C_v} \left( \frac{dQ}{dt} - p_{cyl} \frac{dV_{cyl}}{dt} \right) \quad (4)$$

From the equations (3) and (4), we obtain the following final state equation for cylinder pressure:

$$\frac{dp_{cyl}}{dt} = \frac{\gamma}{V_{cyl}} \left[ RT_{in} \dot{m}_{in} - RT_{cyl} \dot{m}_{cyl} - p_{cyl} \dot{V}_{cyl} \right] \quad (5)$$

$$\frac{\gamma - 1}{V_{cyl}} \left[ \dot{m}_{fb} Q_{LHV} - \dot{Q}_{ht} \right]$$

$\lambda$  is the specific heat ratio ( $\lambda = C_p / C_v$ )

### 3.3. Equations of Heat Transfer, Combustion and Friction losses

#### 3.3.1. Heat Exchange Correlation

Heat transfer at cylinder walls are represented by the Woschni correlation modified by Hohenberg [12], with the ideal gas, the instantaneous convective heat transfer rate from the in-cylinder gas to cylinder wall  $\dot{Q}_{ht}$  is calculated by [7]:

$$\frac{dQ_{ht}}{dt} = A_{cyl} h_t (T_{cyl} - T_{wall}) \quad (6)$$

$T_{wall}$  is the temperature walls of the combustion chamber (bounded by the cylinder head, piston head and the cylinder liner). From the results of Rakapoulos and al. [13],  $T_{wall}$  is assumed constant.

The heat transfer coefficient  $h_t$  in [kW/K.m<sup>2</sup>] at a given piston position, according to Hohenberg's correlation [12] is:

$$h_t(t) = k_{hoh} p_{cyl}^{0.8} V_{cyl}^{-0.06} T_{cyl}^{-0.4} (v_{pis} + 1.4)^{0.8} \quad (7)$$

$p_{cyl}$  is the cylinder pressure,  $V_{cyl}$  the in cylinder gas volume at each crank angle position and  $k_{hoh}$  is Hohenberg's constant that characterises the engine, ( $k_{hoh} = 130$ ).

### 3.3.2 Combustion model

In this paper, we chose the single-zone combustion model proposed by Watson and al [4]. This model reproduces in two combustion phases, the first is the faster combustion process (premixed combustion) and the second is the diffusion combustion which is slower and represents the main combustion phase. During the combustion phase, but the term  $\dot{Q}_{comb}$  is equal to zero apart from this phase. So the amount of heat release  $\dot{Q}_{comb}$  is assumed proportional to the burned fuel mass:

$$\frac{dQ_{comb}}{dt} = \frac{dm_{fb}}{dt} h_{for} \quad (8)$$

$$\frac{dm_{fb}}{dt} = \frac{dm_{fb}^*}{dt} \frac{m_f}{\Delta t_{comb}} \quad (9)$$

The combustion process is described using an empirical model, the single-zone model obtained by Watson and al. [4]:

$$\frac{dm_{fb}^*}{dt} = \beta \left( \frac{dm_{fb}}{dt} \right)_p + (1 - \beta) \left( \frac{dm_{fb}}{dt} \right)_d \quad (10)$$

$\frac{dQ_{comb}}{dt}$  is the rate of heat release during combustion [kJ/s],  $\frac{dm_{fb}}{dt}$  is the burned fuel mass rate [kg/s],  $h_{for}$  the enthalpy of formation of the fuel [kJ/kg],  $\frac{dm_{fb}^*}{dt}$  is the normalized burned fuel mass rate,  $m_f$  is the fuel mass injected per cycle [kg/cycle],  $\left( \frac{dm_{fb}}{dt} \right)_p$  is the normalized fuel burning rate in the premixed combustion,  $\left( \frac{dm_{fb}}{dt} \right)_d$  is the normalized fuel burning rate in the diffusion combustion, and  $\beta$  the fraction of the fuel injected into the cylinder and participated in

the premixed combustion phase.

### 3.3.3 Friction losses

The friction losses not only affect the performance, but also increase the size of the cooling system, and they often represent a good criterion of engine design. So the friction mean effective pressure is calculated by [2]:

$$fmep = C + (0.005 p_{max}) + 0.162 v_{pis} \quad (11)$$

$p_{max}$  is the maximal cycle pressure [bar], for direct injection diesel engine  $C = 0.130$  bar. To evaluate the differential equation (4) or (5), all terms of the right side must be found. The most adapted numerical solution method for these equations is the Runge - Kutta method.

### 3.4. Effective power and effective efficiency

The effective power  $bpower$  for 4-stroke engine is [14]:

$$bpower = bmep V_d N_{cyls} N / 2 \quad (12)$$

$V_d$  is the displacement volume [m<sup>3</sup>],  $V_d = \pi D^2 S / 4$ ,  $N_{cyls}$  is the cylinder number.

The effective efficiency  $R_{eff}$  is given by [15]:

$$R_{eff} = W_d / Q_{comb} \quad (13)$$

$Q_{comb}$  is the heat release during combustion [kJ].

## 4. Simulation programs of supercharged diesel engines

### 4.1 Computing steps of the developed simulation program

The calculation of the thermodynamic cycle according to the basic equations mentioned above requires an algorithm for solving the differential equations for a large number of equations describing the initial and boundary conditions, the kinematics of the crank mechanism, the engine geometry, the fuel and kinetic data. It is therefore wise to choose a modular form of the computer program. The developed power cycle simulation program includes a main program as an

organizational routine, but which incorporates a few technical calculations, and also several subroutines. The computer program calculates in discrete crank angle incremental steps from the start of the compression, combustion and expansion stroke.

The program configuration allows through subroutines to improve the clarity of the program and its flexibility. The basis of any power cycle simulation is above all the knowledge of the combustion process. This can be described using the modified Wiebe function including parameters such as the combustion time and the fraction of the fuel injected into the cylinder. For the closed cycle period, Watson recommended the following engine calculation crank angle steps: 10 °CA before ignition, 1° CA at fuel injection timing, 2° CA between ignition and combustion end, and finally 10 ° CA for expansion [16].

#### 4.2 Simulation with the GT-Power software

The GT-Power is a powerful tool for the simulation of internal combustion engines for vehicles, and systems of energy production. Among its advantages is the facility of use and modeling. GT-Power is designed for steady state and transient simulation and analysis of the power control of the engine. The diesel engine combustion can be modeled using two functions Wiebe [17]. GT-Power is an object-based code, including template library for engine components (pipes, cylinders, crankshaft, compressors, valves, etc...). Figure 3 shows the model of a turbocharged diesel engine with 6 cylinders and intercooler made with GT-Power. In the modelling technique, the engine, turbocharger, intercooler, fuel injection system, intake and exhaust system are considered as components interconnected in series. In the intake manifold, the thermal transfers are negligible in the gas-wall interface; this hypothesis is acceptable since the collector's temperature is near to the one of gases that it contains. The variation of the mass in the intake manifold depends on the

compressor mass flow and the flow through of valves when they are open. In the modeling view, the line of exhaust manifold of the engine is composed in three volumes; the cylinders are grouped by three and emerge on two independent manifold, component two thermodynamic systems opened of identical volumes, and a third volume smaller assures the junction with the wheel of the turbine. The turbocharger consists of an axial compressor linked with a turbine by a shaft; the compressor is powered by the turbine which is driven by exhaust gas. So more air can be added into the cylinders allowing increasing the amount of fuel to be burned compared to a naturally aspirated engine [18]. The heat exchanger can be assimilated to an intermediate volume between the compressor and the intake manifold; it solves a system of differential equations supplementary identical to the manifold. It appeared to assimilate the heat exchanger as a nondimensional organ.

Tab.1. Injection system parameters [17]

Injectors parameters	Values
Injection pressure, (bar)	1000
Start of injection bTDC, (°CA)	15° BTDC
Number of holes per nozzle, (-)	8
Nozzle hole diameter, (mm)	0.25

#### 5. Results of engine simulation

Thermodynamic and geometric parameters chosen in this study are:

- *Engine geometry*: compression ratio  $C_r$ , cylinder bore  $D$  and more particularly the stroke-bore ratio  $R_{sb} = \frac{L}{D}$ .
- *Combustion parameters*: injected fuel mass  $m_f$ , crankshaft angle marking the injection timing  $T_{inj}$ , and cylinder wall temperature  $T_{wall}$ .

The following table (Tab.2) show the main parameters of the chosen direct-injection diesel engine [16, 17].

The combination of two curves (brake power versus engine speed and effective efficiency versus engine speed) allows the creation of a third one: the brake power function of the

effective efficiency as shown in Figure 4. The latter highlights two privileged operating points for the engine: a mode of maximum efficiency and another one of maximum power for the same conditions.

**5.1 Influence of the geometric parameters**  
**5.1.1 Influence of the compression ratio**

In general, increasing the compression ratio improved the performance of the engine [16]. Figure 5 shows the influence of the compression ratio ( $C_r = 16:1$  and  $19:1$ ) on the brake power and effective efficiency at full load, advance for GT-Power and the elaborate software as shown in Figure 6. The

brake efficiency increases with increase of the effective power until its maximum value, after it begins to decrease until a maximal value of the effective power. It is also valid for the effective power. For engine speed of 1600 rpm, if the compression ratio increase from 16:1 to 19:1, the maximal efficiency increases of 2% and the maximal power of 1.5% for GT-Power and the elaborate software. The gap of the results obtained with the two programs (FORTRAN and GT-Power) is due to combustion models used. For the compression ratio  $C_r = 19:1$ , the average deviation does not exceed 9% for the effective power and efficiency.

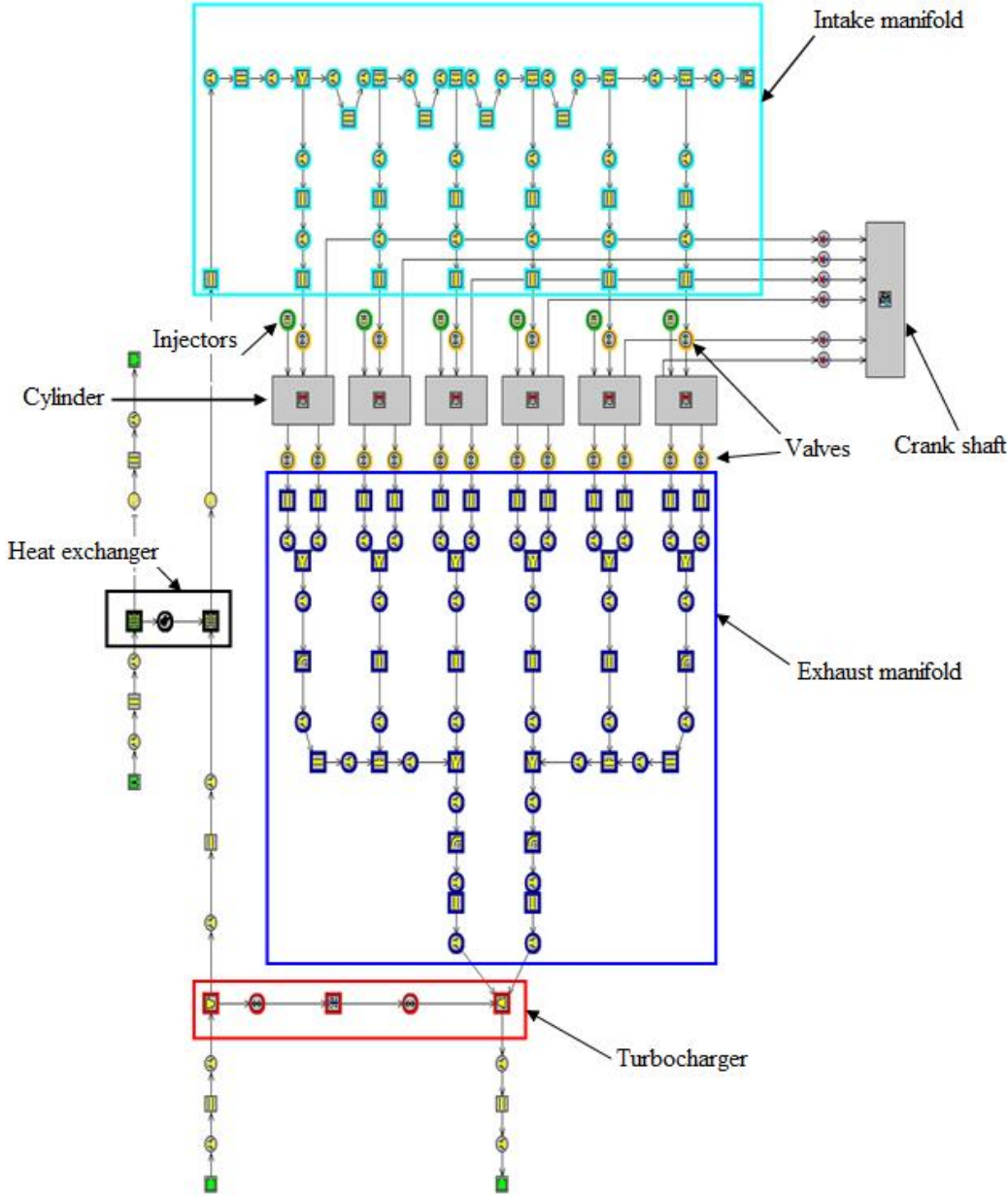

Fig.3: Developed model of the 6-cylinders turbocharged engine using the GT-Power software

### 5.1.2 Influence of the cylinder diameter

Figure 7 shows the influence of cylinder diameter on the effective power at full load 100%, a compression ratio of 16:1 and advance injection of 15° bTDC. The brake efficiency increases with increase of the effective power until its maximum value, after it begins to decrease until a maximal value of the effective power. If the cylinder diameter increases by 10 mm (from 130 to 140 mm), the brake efficiency decreases by 2 % and the effective power by 9%.

Tab.2: Engine specifications [17].

Engine parameters	Values
Bore, D (mm)	120.0
Stroke, S (mm)	175.0
Displacement volume, $V_d$ (cm <sup>3</sup> )	1978.2
Connecting rod length, $l$ (mm)	300.0
Compression ratio, (-)	16.0
Inlet valve diameter, (mm)	60
Exhaust valve diameter, (mm)	38
Inlet Valve Open IVO, (°CA)	314
Inlet Valve Close IVC, (°CA)	-118
Exhaust Valve Open EVO, (°CA)	100
Exhaust Valve Close EVC, (°CA)	400
Injection timing, (°CA)	15° BTDC
Fuel system, (-)	D. injection
Firing order, (-)	1-5-3-6-2-4

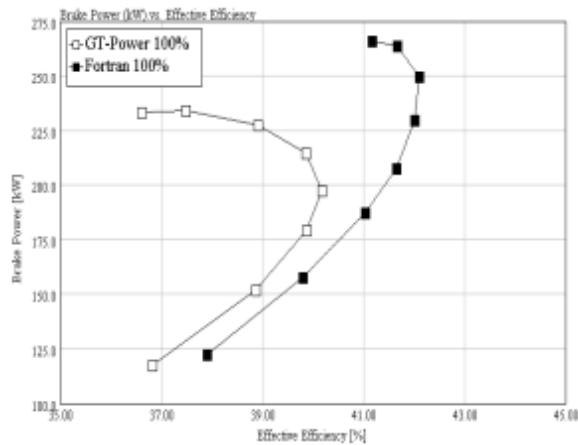

Fig.4: Brake power versus effective efficiency for full load,  $T_{inj} = 15^\circ$  bTDC,  $D_{cyl} = 120$  mm,  $C_r = 16:1$ ,  $T_{wall} = 450$  K,  $R_{sb} = 1.5$ .

### 5.1.3 Influence of the stroke-bore ratio

The stroke-bore ratio is another geometric parameter that influences on the performances of a turbocharged diesel engine. The Cylinder volume of 2.0 l can be obtained in a different manner while varying this parameter; its influence is shown in

Figure 8. If the stroke-bore ratio increase, the

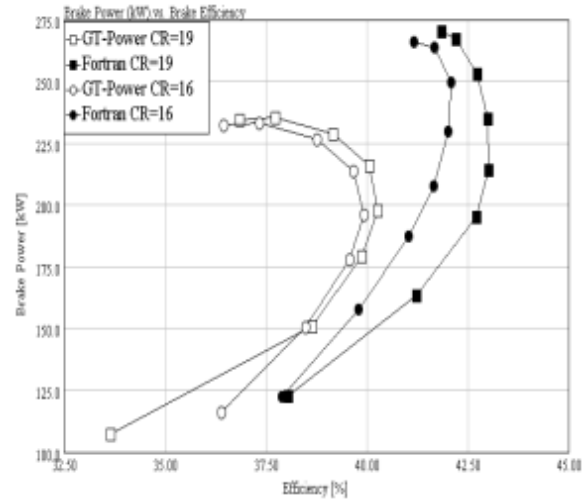

Fig.5: Compression ratio influence at 100% load,  $T_{inj} = 15^\circ$  bTDC,  $D_{cyl} = 120$  mm,  $T_{wall} = 450$  °K,  $R_{sb} = 1.5$ .

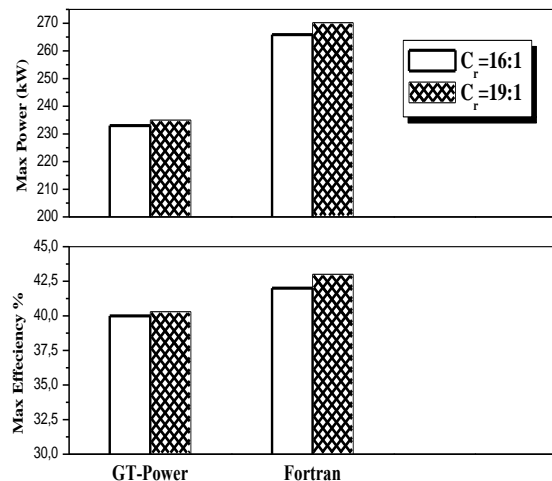

Fig.6: Maximum power and maximum efficiency for different compression ratio.

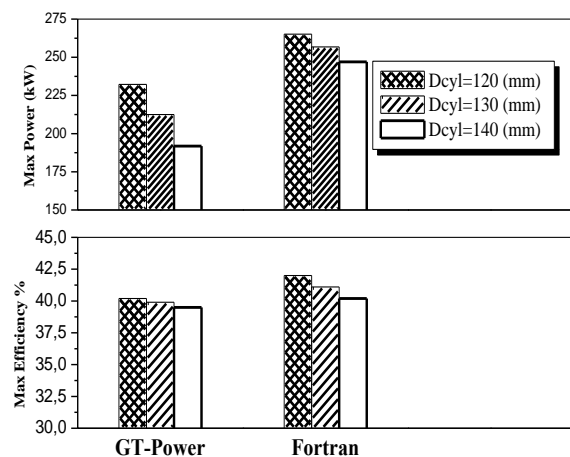

Fig.7: Maximum power and maximum efficiency for different cylinder diameter,  $D_{cyl} = 120, 130$  and 140 mm

mean piston speed is greater, and friction losses (Eq.11) need to be considered while increasing the engine speed (Figure 9). The



effective power and the brake efficiency decrease with an increase in the stroke-bore ratio. While the stroke-bore ratio increased from 1.5 to 2, then the maximum brake efficiency decreased by an average of 3%, and the maximum effective power by 4%. For a stroke-bore ratio  $R_{sb} = 1.0$ , the average difference between the results with two programs is 9% for the effective power and 7% for the effective efficiency at full load.

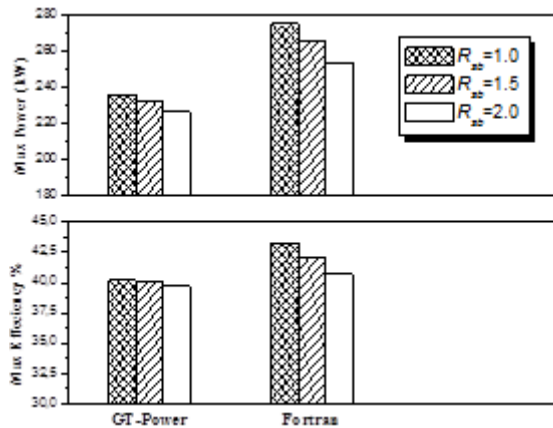

Fig.8: Maximum power and maximum efficiency for different stroke bore ratio,  $R_{sb} = 1.0, 1.5$  and  $2.0$ .

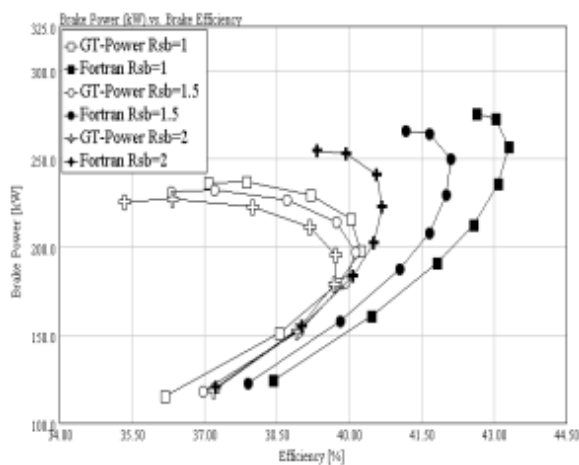

Fig.9: Influence of Stroke bore ratio for 100% load,  $T_{inj} = 15^\circ$  bTDC,  $v_{cyl} = 2.0$  l,  $C_r = 16:1$ ,  $T_{wall} = 450$ K.

## 5.2 Influence of the thermodynamic parameters

### 5.2.1 Influence of the wall temperature

The influence of the cylinder wall temperature is represented in Figures 10 and 11. When the cylinder wall temperature is lower, the brake efficiency improves. From Figure 11, we note that more the temperature deviation between gas and wall cylinder becomes less, the losses by convective exchange are higher [13]. By increasing the

cylinder wall temperature from 350 K to 450K, the maximum of brake power and effective efficiency decrease respectively by about 1%. The maximal operating engine temperature is limited by mechanical, thermal and design constraints. Increasing the temperature of the cylinder walls leads to a reduction of engine performance. Therefore, it is advantageous to improve the cooling of the hot parts of the engine.

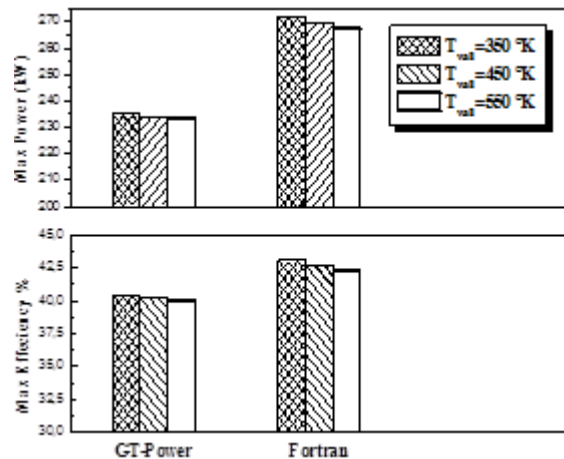

Fig.10: Maximum power and maximum efficiency for different cylinder wall temperature.

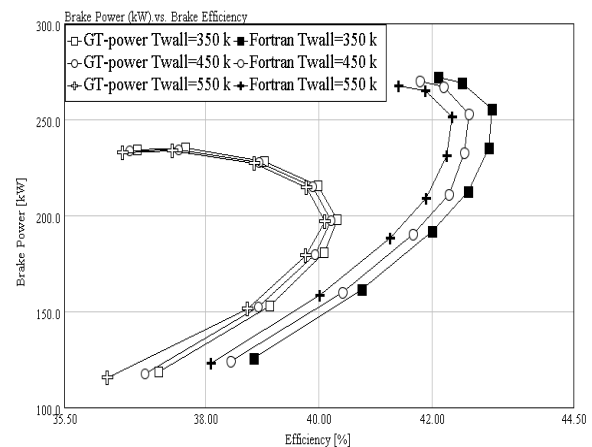

Fig.11. Wall temperature influence for 100% load,  $T_{inj} = 15^\circ$  bTDC,  $D_{cyl} = 120$  mm,  $C_r = 16:1$ ,  $R_{sb} = 1.5$ .

It is observed that with the increase of engine rotation speed gaps of the results obtained with both programs become larger. These are due to pressure losses in the intake pipes and in the inlet of the turbocharger. In the developed program, these losses were expressed by a lower and constant pressure loss coefficient. For this reason, the effective power and efficiency calculated with the

developed program are greater than those with GT-Power. At a cylinder wall temperature  $T_{wall} = 550$  K, the average differences between two programs are in the order of 8% for effective power and efficiency.

### 5.2.2 Influence of the advanced injection

Figure 12 show the influence of different injection timings on the variation of the maximum brake power versus the maximum effective efficiency for the both software; Fortran and GT-Power. This parameter has a substantial influence on the brake power and less on effective efficiency. An injection advance from 5 aTDC to 15° before TDC increased the heat flow from fluid to the combustion chamber wall.

For an injection timing  $T_{inj} = 15^\circ$  bTDC, the mean gaps between both programs are about 7 % for the effective power and effective efficiency.

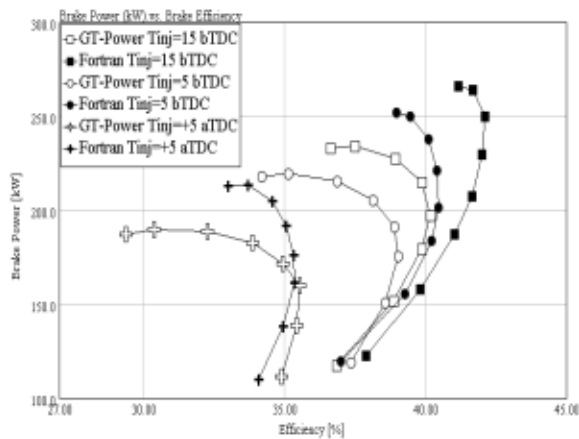

Fig.12. Injection timing influence for 100% load,  $D_{cyl} = 120$  mm,  $C_r = 16:1$ ,  $T_{wall} = 450$  K,  $R_{sb} = 1.5$ .

Figure 13 presents the influence of the injection timing and its impact on the form of the thermodynamic cycle of the pressure and temperature in the cylinder. When the injection starts at 15° before TDC the maximal pressure and temperature are higher, and the temperature at the exhaust is lower than if the injection timing occurs at 5° after the TDC [19, 20]. In this case the combustion begins whereas the piston starts its descent, the duration of heat exchange losses is lower, and then the exhaust temperature is higher.

### 5.2.3 Influence of the masse fuel injected

Figures 14 and 15 shows the variation of the brake power versus effective efficiency for different masse fuel injected at advance injection of 15° bTDC, compression ratio of 16:1, and  $N = 1400$  RPM. This parameter has a strong influence on the brake power, heat flux and it has a less influence on the effective efficiency. The brake power and effective efficiency increases with increasing the quantity of fuel injected. At full load, the average differences of the results obtained with both programs used are 7% for the effective power and 5% for the effective efficiency. With an increase of the mass of fuel injected of 50%, there is an improvement of the effective efficiency of 3.5% and the brake power of 29% and the heat flux of 15%. This clearly shows the importance of the variation of the quantity of injected fuel in achieving the effective power and the brake efficiency.

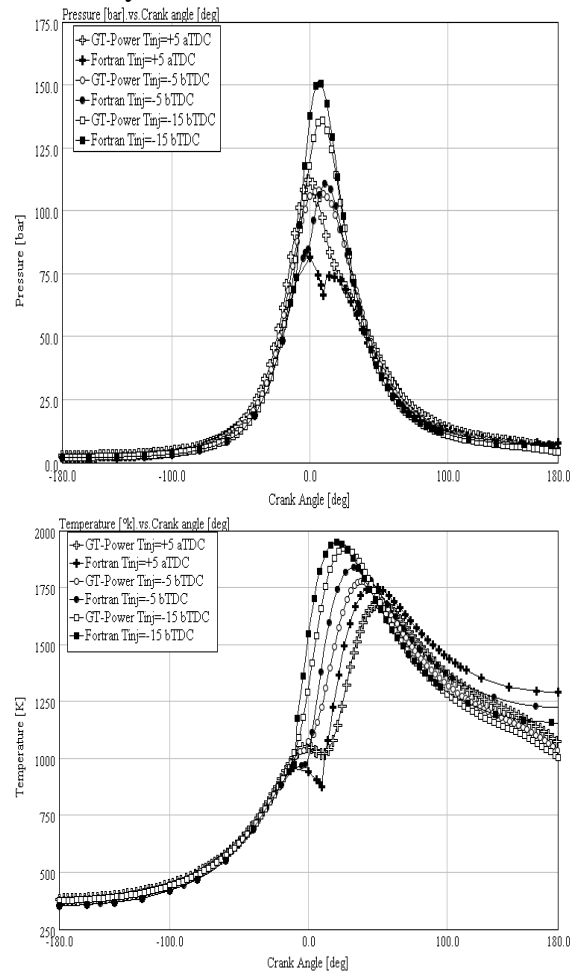

Fig.13: Injection timing influence on gas pressure and

temperature versus crankshaft for 100% load,  $D_{cyl} = 120$  mm,  $C_r = 16:1$ ,  $T_{wall} = 450$  K,  $R_{sb} = 1.5$ ,  $N = 1400$  rpm.

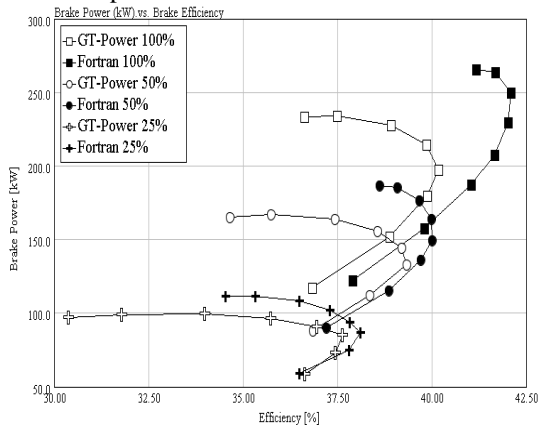

Fig. 14: Mass fuel injected influence for  $T_{inj} = 15^\circ$

bTDC,  $D_{cyl} = 120$  mm,  $C_r = 16:1$ ,  $T_{wall} = 480$  K.

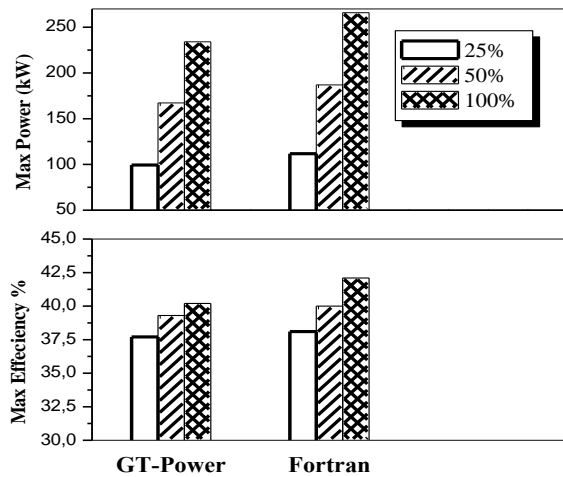

Fig.15: Maximum power and maximum efficiency for different mass fuel injected; 25%, 50% and 100%.

## 6. Conclusion

This work describes a turbocharged direct injection compression ignition engine simulator. Effort has been put into building a physical model based on the filling and emptying method. The resulting model can predict the engine performances. From the thermodynamic model we are able to develop an interrelationship between the brake power and the effective efficiency that is related to the corresponding speed for different parameters studied; it results an existence of a maximum power corresponding to a state for an engine optimal speed and a maximum economy and corresponding optimal speed. We studied the influence of certain number of parameters on engine power and

efficiency: The following parameters as; stroke-bore ratio and the cylinder wall temperature, have a small influence on the brake power and effective efficiency and heat flux. While the angle of start injection, mass fuel injected, compression ratio have great influence on the brake power and effective efficiency and heat flux. The engine simulation model described in this work is valid for a quasi-steady state. The developed numerical simulation model was validated with the GT-Power Program by applying of data of a typical turbocharged diesel engine. This model is valid for other diesel engines of similar configuration respecting the simplifying assumptions. It is quite evident that the GT-Power computer program gives quantitatively different results compared to developed simulation program. However, under qualitative aspect, the obtained results with both programs provide a good agreement.

In future investigations, we will try to improve the model developed taking into account the real pressure losses in the intake pipe, the evacuation process of burned gas, the mixture preparation according to combustion chamber form, the combustion model and the cooling of the cylinder-cylinder head assembly.

## 7. References

- [1] Angulo-Brown F, Fernandez-Betanzos J and Diaz-Pico CA, "Compression ratio of an optimized Otto-cycle model," *European journal of physics* 1994; 15: pp. 38–42.
- [2] Chen L, Lin J, Lou J, Sun F and Wu C, "Friction effect on the characteristic performances of Diesel engines," *International Journal of Energy Research* 2002; 26: pp.965–971.
- [3] Merabet A, Feidt M and A. Bouchoucha, "Effet du transfert de chaleur sur les performances d'un moteur a ` combustion interne atmosphérique fonctionnant suivant un cycle mixte," *Termotecnica* 2002; 2: pp.43–46.
- [4] Watson N, Pilley AD and Marzouk M, "A combustion correlation for diesel engine simulation," In: *SAE Technical Paper*

(1980), 1980-800029.

[5] Stefanopoulou A, "Modeling and control of advanced technology engines," PhD thesis, University of Michigan, 1996.

[6] Guzzella L and Amstutz A, "Control of diesel engines," *IEEE Transaction on Control Systems* October 1998; 18: pp.53–71.

[7] Heywood JB, "Internal Combustion Engine Fundamentals," McGraw-Hill, New York, 1988.

[8] Ledger JD and Walmsley S, "Computer simulation of a turbocharged diesel engine operating under transient load conditions," *SAE Technical Paper* 1971, 710177.

[9] Benson RS and Baruah PC, "Some further tests on a computer program to simulate internal combustion engine," *SAE Technical Paper* 1973, 730667.

[10] Winterborne DE, Thiruarooran C and Wellstead PE, "A wholly dynamical model of a turbocharged diesel engine for transfer function evaluation," *SAE Technical Paper*, 1977; 770124.

[11] Sakhrieha A and Abu-Nada E, "Computational Thermodynamic Analysis of Compression Ignition Engine," *International Communications in Heat and Mass Transfer* 2010; 37; pp. 299–303.

[12] Hohenberg GF, "Advanced approaches for heat transfer calculations," *SAE Technical Paper* 1979, 1979-790825.

[13] Rakopoulos CD, Rakopoulos CD, Mavropoulos GC and Giakoumis EG, "Experimental and theoretical study of the short-term response temperature transients in the cylinder walls of a diesel engine at various operating conditions," *Applied Thermal Engineering* 2004; pp. 679-702.

[14] Semin RB and Ismail R, "Investigation of Diesel Engine Performance Based on Simulation," *American Journal of Applied Sciences* 2008; 5: pp.610-617.

[15] Dec JE, "Advanced compression ignition engines-understanding the in-cylinder processes," *Proc. Combust. Inst.* 2009; 32: pp. 2727–2742.

[16] Menacer B and Bouchetara M; "simulation and prediction of the performance of a direct turbocharged diesel engine",

*simulation*; 2013.

[17] Gamma Technologies, *GT-Power User's Manual*, GT-Suite Version 7.0, 2009.

[18] Galindo J, Arnau FJ, Tiseira A and Piqueras P, "Solution of the Turbocompressor Boundary Condition for One-Dimensional Gas-Dynamic Codes," *Mathematical and Computer Modelling* 2010; 52; pp.1288-1297.

[19] Feidt M and Descieux D, "Modelling of a Spark Ignition Engine for Power-Heat Production Optimization," *Oil & Gas Science and Technology – Revue. IFP Energies nouvelles* 2011; 5: pp. 737-745.

[20] Ebrahimi R, "Performance of an Irreversible Diesel Cycle under Variable Stroke Length and Compression Ratio," *Journal of Ambient Science* 2009; 7: pp. 58-64.