

## Use of Learning Analytics Applications in Mathematics with Elementary Learners

Martin Ebner<sup>1</sup>

Graz University of Technology, Graz

Matthias Pronegg

Graz University of Technology, Graz

### Abstract

This paper describes a study about the use of learning analytical applications in everyday school life. The research study took place in an Austrian secondary school during the mathematics courses. The subjects of the courses were the four basic arithmetical operations in the set of the natural numbers. All together two mathematics classes with 46 children at the age of 10 to 11 participated in this study. The aim was to test the usefulness of mathematics trainers, developed by the University of Technology in Graz, under real conditions. Therefore, one of the classes was determined as the experimental group, which studied with the mathematics trainers. The other class was set as the control group. This class operated with traditional exercise sheets. A pre-test and post-test control-group study indicated that the use of mathematics trainers does not decrease learning outcomes, but it points out other benefits during the whole learning arrangement. These advantages include error analysis, time saving in comparing the homework and enjoying the work with the trainers.

**Submitted**

27 April 2015

**Revised**

25 May 2015

**Accepted**

03 July 2015

**Keywords:**

*Mathematics,  
learning analytics,  
learning analytical  
applications,  
elementary learners.*

### Suggested Citation:

Ebner, M. & Pronegg, M. (2015). Use of Learning Analytics Applications in Mathematics with Elementary Learners. *International Journal of Academic Research in Education*, 1(2), 26-39. DOI: 10.17985/ijare.37247

<sup>1</sup> Corresponding author: Graz University of Technology, [martin.ebner@tugraz.at](mailto:martin.ebner@tugraz.at), Phone: +43 316 873 8540

## INTRODUCTION

Nowadays, the use of new media and technologies in school life becomes more and more standard. For example; teachers use computers along with video projectors and pupils study with different learning platforms. Even more in some schools the children of a class are equipped with tablets (Ebner, Schönhart, & Schön, 2014a). Due to this, the technology is used in every course (Frangenberg, 2014).

Learning and teaching are subjects to ongoing change and improvement. Both activities are adapted to the latest state of research and to the current associated media and technologies. Programs, which support learning and teaching, are called educational software. There are different requirements for this kind of software. Educational software should be designed for different types of learners and different forms of learning. This software also should allow pupils individual learning (Erpenbeck & Sauter, 2013; Hugger & Walber, 2010).

Technologies and software, which are able to analyze the learning progress and typical errors of pupils are rare. The University of Technology in Graz has developed mathematics trainers, which have the ability for that (Ebner & Schön, 2013). These applications are at free disposal and these programs are available on different websites (For example; <http://schule.learninglab.tugraz.at>). These programs are called learning analytical applications. This kind of software is able to analyze single learning steps. Furthermore, it is able to detect individual errors of the learners. The software provides error, problem and improvement analyzes. Consequently, following the learning analytical approach (Long & Siemens, 2011) learners are additionally supported by coaches (Erpenbeck & Sauter, 2013; Mavani, 2010).

Clow (2011) describes the use of the learning analytical applications with the learning analytics cycle. The learners provide data and this data is analyzed by the application. Therefore, the behaviour of the pupils can be monitored. After a didactical intervention, the circle starts again. Similar to Greller & Drachlser (2012) pedagogy and data analysis are separated. Especially in mathematics error analyzes and promoting of individual learning is important (Carroll, 1994). Based on this the research study was carried out as typical field study with a pre-post-control-group design aiming to test the usefulness of the mentioned mathematics trainers, developed by the University of Technology in Graz, under real conditions.

### *Purpose of the Study*

The purpose of the present field study is to test the six hypotheses (HY) formed below:

**HY 1:** The learning progress of pupils, who use learning analytical applications, is higher than the learning progress of pupils, who work with traditional exercise sheets.

**HY 2:** The learning progress in multiplication and division is higher than the learning progress in addition and subtraction.

In primary school addition and subtraction are taught more often than multiplication and division. Multiplication and division are trained more intensive in secondary school (www.bmbf.at, 2015c) (www.bmbf.at, 2015d).

**HY 3:** Learning analytical applications indicate systematic errors in the four basic arithmetical operations.

The use of learning analytics applications in class has advantages for teachers. One of these advantages would be the analytics of systematic periodic errors (Erpenbeck & Sauter, 2013; Mavani, 2010; Vollrath & Roth, 2012).

**HY 4:** Pupils prefer the "Plusminus-Trainer".

Research has indicated, that pupils have subjective perceptions concerning the difficulty of the four basic arithmetical operations (Scherer & Moser-Opitz, 2010).

**HY 5:** Talented pupils compute more examples with learning analytical applications as requested.

Talented pupils often learn based on achievement motivation, to gain their own aims (Schlag, 2013).

**HY 6:** Pupils have problems with learning analytical applications using them for the first time.

Research has been indicated, that pupils have problems with the use of learning analytical applications (Brinkman, Payne, & Underwood, 2008; Yang, 2010).

Based on the contents of these hypotheses two questions (Q) have been formed.

**Q1:** *Which learning progress can be achieved with the use of learning analytical applications in mathematics?*

This question concerns the learning progress of the pupils.

**Q2:** *How is the behaviour of pupils in using mathematics trainers?*

Question 2 concerns to the behaviour of pupils using learning analytical applications.

## METHOD

The research was conducted based on pre-test and post-test control-group design. The main points of this study are participants, study design, experimental design, materials and the pre-and post-tests. A total of 46 participants aged 10 to 11 in an Austrian secondary school participated in this overall the survey. 26 of these pupils were female and 20 were male.

The study took place during the mathematics over a period of five weeks. Both investigated classes have been taught by the same teacher. The examiner did not manipulate the lessons and assumed the role of the observer. This survey intended to establish if homework and lessons were influenced indirectly by the project.

In order to create two comparison groups, one of these class was defined as the experimental group (EG) and the other class was set as the control group (CG). Class one was chosen as the EG, because this class had more pupils as the other class and so more pupils worked with the mathematics trainers. The style of teaching in both groups was face-to-face with training periods.

The independent variable was set as the different style of homework. The examiner instructed the teacher to give homework in both classes. The CG got traditional homework in form of exercise sheets and the EG got homework with the trainers. This is indicated in *Table 1*.

*Table 1: Study design*

Class	Homework	Lesson
Experimental Group	Mathematics trainers	Face –to-face and training
Control group	Traditional exercise sheets	phases

The dependent variable was set as the learning progress in both groups. The progress was measured by the difference of post and pre-test.

### Experimental Design

The entire study can be classified in three phases: Preparation phase, experimental phase and follow-up phase as indicated in *Figure 1*.

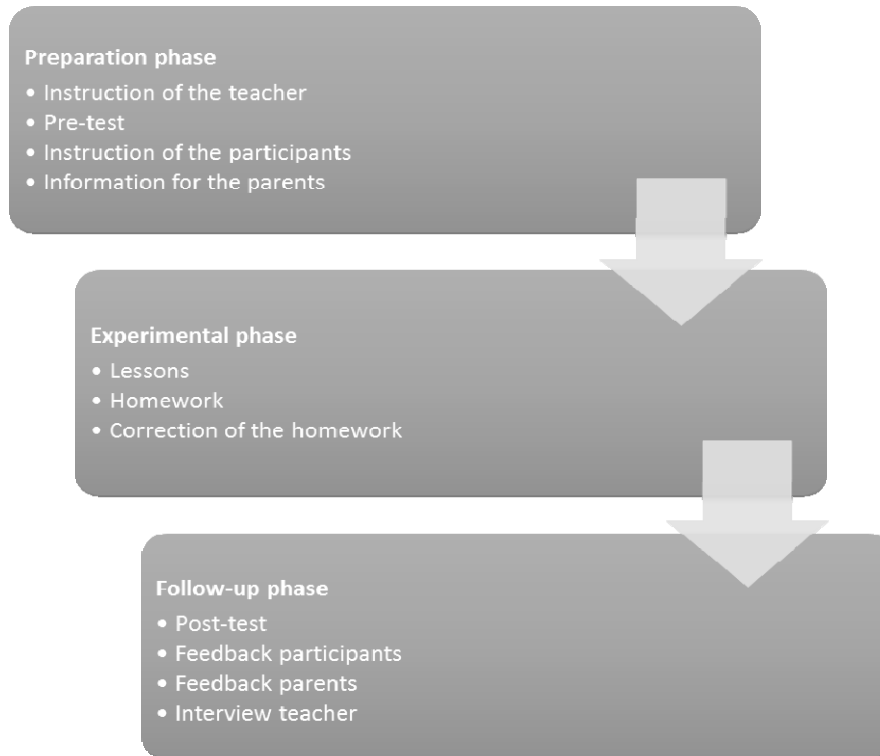

*Figure 1: Procedure of the study*

#### Preparation phase

- *Instruction of the teacher*

The examiner instructed the teacher to give homework and to design similar lessons in both classes.

- *Pre-test*

The pre-test in both classes was managed by the teacher. The pupils had ten minutes to solve the test.

- *Instruction of the participants*

In this lesson the children of the EG were instructed by the examiner about the functionality of the mathematics trainers and they got their access data.

- *Information for the parents*

The parents were informed about the project in form of a letter.

#### Experimental phase

- *Lessons*

The lessons in both classes were designed similarly and were usually held face-to-face. The examiner observed the lessons, but did not influence the teaching process in any means.

- *Homework*

All homework was given by the teacher.

- *Correction of the homework*

The correction of the homework was made by the examiner. In case of serious mistakes or missing homework the examiner informed the teacher immediately.

### Follow-up phase

- *Post-test*

The post-test in both classes was managed by the teacher. This test was made under the same conditions as the pre-test.

- *Feedback participants*

At the end of the project feedback was given by the participants.

- *Feedback parents*

In order to find out how the pupils worked at home a feedback session was performed with the parents.

- *Interview teacher*

In order to recognise the view of the teacher the examiner carried out an interview.

### *Materials*

The pupils of the experimental group studied during their homework with the mathematics trainers of the TU Graz. (<http://schule.learninglab.tugraz.at>) Figure 22 indicates the graphical user interface of the “Mathemulti-Trainer” (Ebner, Schön, Taraghi, & Steyrer, 2014b). The interface and the functionality of the “Plusminus-“ (Ebner, Schön & Neuhold, 2014c) and the “Divisions-Trainer” are similar to the “Mathemulti-Trainer”. The system of the trainer indicates the child a calculation, who has to fill out the appropriate form fields. When the child has finished the calculation, he/she can check his/her result by pushing a button. The system gives the operator an immediate response and the user is always able to check his learning progress in the included statistics.

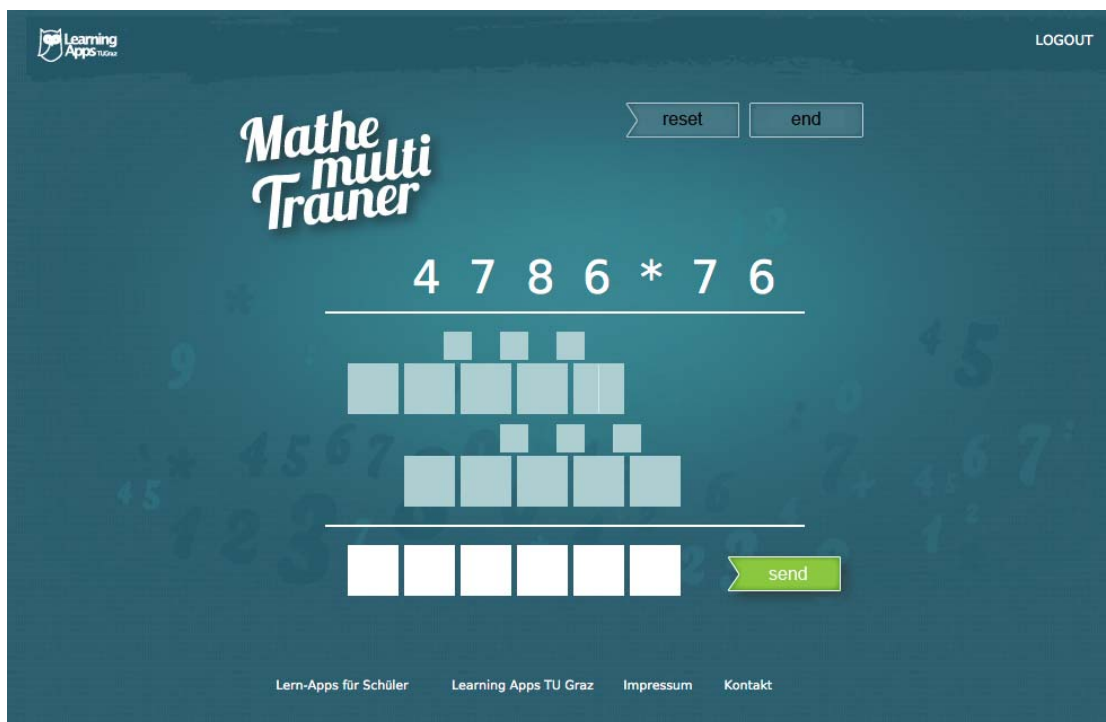

Figure 2: “Mathemulti-Trainer” TU Graz

### Exercise sheets

The participants of the control group trained in the four basic arithmetic operations with traditional exercise sheets. The calculations on these sheets were designed with free space. So the pupils didn't have to copy the calculations into their books.

### *Pre- and post-tests*

The test which was used to measure the learning progress was the same in both comparison groups. The calculations of the pre-test and of the post-test were equal too. Altogether this test consists of ten calculations. (2 additions, 2 subtractions, 4 multiplications and 4 divisions) In order to get a noticeable difference or a learning progress the test was prepared at a high level of difficulty.

### *Collected Data of the Study*

Following data has been collected:

- Learning progress
- Working development
- Feedback (parents and pupils)
- Interview teacher

## RESULTS

### *Hypothesis 1*

To test the first hypothesis the results of the pre- and post-test were used. The learning progress is the difference between the correct calculations of the post-test and the correct calculations of the pre-test. *Figure 3* indicates that the experimental group had 0,86 correct calculations on average. The learning progress in the control group was 1,05 calculations.

A similar result indicates the Box-Whisker-Plot in *Figure 3*. The graphs of both comparison groups are similar to each other.

Because of this small difference between both groups in the learning progress, HY 1 cannot be validated.

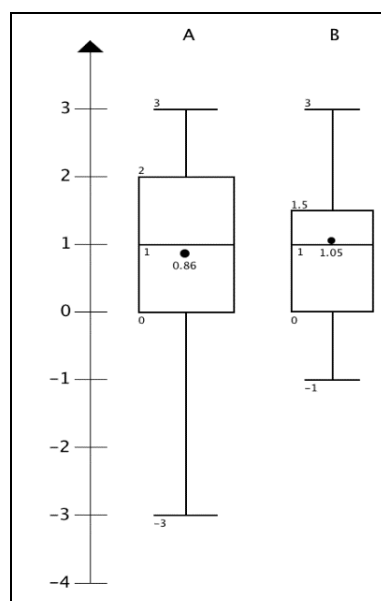

Figure 3: Results experimental group (A) and control group(B)

### Hypothesis 2

Table 2 indicates the learning progress between the control group and the experimental group in the addition-subtraction and multiplication-division. The learning progress in both groups is in multiplication and division higher than in addition and subtraction. Therefore HY 2 can be confirmed.

Table 2: Learning progress addition, subtraction and multiplication and division

	Control group	Experimental group
Average learning progress addition, subtraction	-0,25	-0,09
Average learning progress multiplication, division	1,30	0,95

### Hypothesis 3

In Figure 4 the results of a pupil calculating with the "Mathemulti-Trainer" are indicated. This pupil has problems with the carry in addition during the sub-steps of multiplication.

Gruppe 3x3, 4x3 with carry							
Problem ID	calculation	solution	answer	result	time		Details
20	9646*784	7562464	7562464	Diverse Fehler	00:00:49	2014-11-24 17:15:05	HIER <
23	397*738	292986	292986	Diverse Fehler	00:00:56	2014-11-25 14:24:58	HIER <
24	2738*874	2393012	3393014	Diverse Fehler	00:00:00	2014-11-30 13:27:22	HIER <
25	637*675	429975	429875	Übertrag-Addierfehler (Korrektes 1x1 - kein Addieren)	00:00:00	2014-11-30 13:35:59	HIER <
28	857*368	315376	311976	Übertrag-Addierfehler (Korrektes 1x1 - kein Addieren)	00:04:13	2014-11-30 13:47:51	HIER <
34	986*243	239598	239588	Übertrag-Addierfehler (Korrektes 1x1 - kein Addieren)	00:00:00	2014-11-30 13:56:50	HIER <
35	495*257	127215	226215	Unbekannter Fehler	00:01:58	2014-11-30 13:59:35	HIER <
36	3848*563	2166424		Eingabefehler	00:02:27	2014-11-30 14:03:38	HIER <
37	539*645	347655	347615	Übertrag-Addierfehler (Korrektes 1x1 - kein Addieren)	00:02:49	2014-11-30 14:07:57	HIER <
38	5669*895	5073755	5073755	OK	00:02:13	2014-12-15 17:21:36	HIER <
39	857*973	833861	833861	OK	00:02:44	2014-12-15 17:25:42	HIER <
40	684*497	339948	340948	Unbekannter Fehler	00:00:00	2014-12-15 17:32:10	HIER <

nach oben ↑

Figure 4: Error multiplication

The system determined, that one pupil has problems with the addition during the multi-digit multiplication. In the category 3x3, 4x3 without carry this person made 6 addition errors in 23 calculations. There are about 26 percent of this category, see Figure 5.



Gruppe 3x3, 4x3 without carry							
Problem ID	calculation	solution	answer	result	time		Details
22	4213*132	556116	556416	Additionsfehler	00:01:31	2014-11-24 17:05:03	> HIER <
24	7132*312	2225184	2225184	OK	00:01:16	2014-11-24 17:07:38	> HIER <
29	631*213	134403	134403	OK	00:01:12	2014-11-24 17:12:53	> HIER <
34	513*231	118503	118503	OK	00:00:00	2014-11-25 16:57:48	> HIER <
35	712*123	87576	87576	OK	00:00:00	2014-11-25 16:59:23	> HIER <
51	5213*213	1110369	1110399	Additionsfehler	00:01:01	2014-11-25 17:34:22	> HIER <
52	7123*321	2286483	1110369	1x1 Fehler	00:00:09	2014-11-25 17:34:40	> HIER <
54	423*312	131976	131976	OK	00:00:00	2014-11-25 17:36:48	> HIER <
55	631*312	196872	196872	OK	00:00:57	2014-11-25 17:37:47	> HIER <
56	723*213	153999	153999	OK	00:00:49	2014-11-29 09:33:36	> HIER <
59	721*123	88683	88683	OK	00:00:44	2014-11-29 09:35:55	> HIER <
70	821*123	100983	100983	OK	00:00:52	2014-11-29 09:41:57	> HIER <
76	813*213	173169	273199	Additionsfehler	00:00:00	2014-11-29 09:51:37	> HIER <
77	832*231	192192	192192	OK	00:00:00	2014-11-29 09:53:01	> HIER <
94	921*312	287352	287352	OK	00:00:00	2014-12-13 12:40:21	> HIER <
96	431*123	53013	53013	OK	00:00:48	2014-12-14 11:33:02	> HIER <
99	832*213	177216	279616	Additionsfehler	00:00:00	2014-12-14 11:37:54	> HIER <
100	921*213	196173	196173	OK	00:00:58	2014-12-14 11:39:23	> HIER <
103	631*123	77613	77613	OK	00:00:53	2014-12-14 11:42:43	> HIER <
107	432*213	92016	92116	Additionsfehler	00:00:00	2014-12-23 12:11:57	> HIER <
112	713*231	164703	164703	OK	00:00:39	2014-12-23 12:15:51	> HIER <
113	6312*123	776376	775376	Additionsfehler	00:00:00	2014-12-23 12:17:03	> HIER <
114	631*132	83292	83292	OK	00:00:00	2014-12-23 12:18:24	> HIER <

Figure 5: Error multiplication 2

Even the “Divisions-Trainer” indicates systematic errors. Figure 6 indicates the error burst of a pupil in category  $dd \div d$ . The most common mistake of this person was: One or more sub products were calculated wrong.

Because of this error HY 3 can be confirmed.

dd:d

id	numerator	Divisor	correct Quotient	correct Rest	calculated Quotient	calculated Rest	correct	error	time
312	15	5	3	0	3	0	No	One or more sub products are calculated wrong	00:02:07 02.12.2014 - 14:45:00
322	16	4	4	0	4	0	No	Unknown Error	00:00:26 02.12.2014 - 14:46:04
348	96	2	48	0	48	0	No	One or more sub products are calculated wrong	00:02:20 02.12.2014 - 14:49:11
363	88	2	44	0	44	0	No	One or more sub products are calculated wrong	00:00:47 02.12.2014 - 14:51:15
370	25	5	5	0	5	0	No	One or more sub products are calculated wrong	00:00:30 02.12.2014 - 14:52:00
374	45	5	9	0	9	0	Yes	-	00:00:29 02.12.2014 - 14:52:44
388	75	5	15	0	15	0	No	One or more sub products are calculated wrong	00:03:29 02.12.2014 - 14:56:20
391	24	4	6	0	6	0	Yes	-	00:00:38 02.12.2014 - 14:57:41
394	46	2	23	0	23	0	No	One or more sub products are calculated wrong	00:02:06 02.12.2014 - 14:59:50
399	72	2	36	0	36	0	No	One or more sub products are calculated wrong	00:03:09 02.12.2014 - 15:03:13
405	75	5	15	0	15	0	Yes	-	00:02:18 02.12.2014 - 15:06:32
409	51	3	17	0	17	0	Yes	-	00:01:39 02.12.2014 - 15:08:19
412	99	3	33	0	33	0	Yes	-	00:00:36 02.12.2014 - 15:08:59
417	85	5	17	0	17	0	Yes	-	00:01:18 02.12.2014 - 15:10:27

<< Zurück

Figure 6: Error division

#### Hypothesis 4

Table 3 indicates that in case of free choice pupils prefer the "Plusminus-Trainer". So HY 4 is confirmed too.

Table 3: Choice of the pupils

Plusminus-Trainer	13
Mathemulti-Trainer	2
Divisions-Trainer	0

### Hypothesis 5

Based on the calculated learning progress *Table 4* was designed. Therefor the participants were assigned in three levels. Level 3 includes pupils, who have a difference of -3 or -2 out of post- and pre-test. Level 2 contains a difference of -1, 0 or 1. Pupils with a high performance level (difference of 2 or 3) are ordered to Level 1. So *Table 4* indicates that 4 learners of level 1, 4 learners of level 2 and 1 learner of level 3 had calculated more examples as required.

*Table 4: Comparison of performance level and calculated more than required*

Performance Level	Learning progress	Amount of learners
<b>Level 3</b>	-3 or -2	1
<b>Level 2</b>	-1, 0 or 1	4
<b>Level 1</b>	2 or 3	4

*Figure 7* indicates a scatter plot of the learning progress and the required calculations during the study. With these data a correlation analysis according to Bravais and Pearson was made (Pruscha, 2006, S.34). The resulting correlation coefficient is 0,39. Cause of this positive correlation and the positive gradient of the regression line in *Figure 7* the following conclusion can be drawn: Rather talented pupils (high learning progress) calculate more calculations as required.

These analyses indicate that rather talented pupils calculated more examples as required. Because of this analysis HY 5 is confirmed.

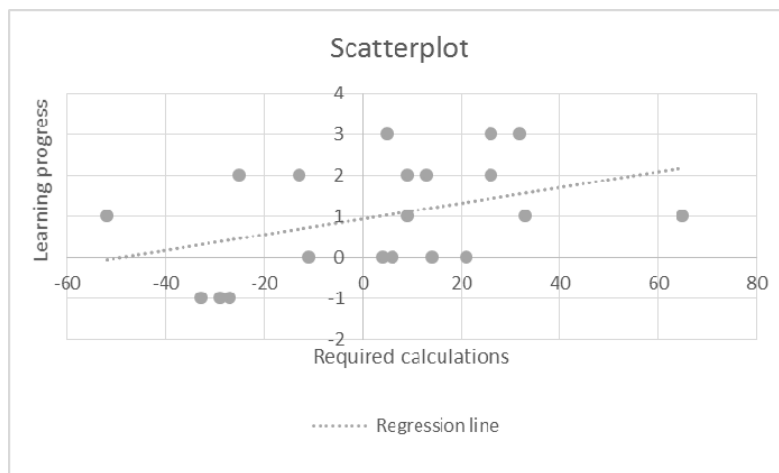

*Figure 7: Scatterplot: learning progress and required calculations*

### Hypothesis 6

Some pupils had problems by using the trainers at home. The participants informed the teacher, that the trainers did not work. But then it turned out, these pupils had problems with entering the link in the browser.

In week three of the project when the children used the "Divisions-Trainer" this problem occurred again. So the examiner linked all three trainers within the learning management system. Some participants had

problems by filling out the form fields in the calculations of the trainers. *Figure 8* indicates the results of the first three calculations of a pupil. As it can be seen this participant made input errors only.

Another problem, which occurred by working with the “Divisions-Trainer” was the alternative view. The calculations in this trainer are standardly indicated in a view where the user has to note a sub product. Then he has to build the difference. In the alternative view the user does not have to do that. The participants of the experimental group have been learned dividing in the alternative view. Before starting calculating the participants had to switch to the alternative view. Some pupils were not able to manage this problem and they told the teacher about that. Because of these occurring difficulties HY 6 is confirmed.

26*94						
multiplication	carry (correct)	solution	carry (answer)	answer	new carry	result
6*9	OFF	54	OFF			Eingabefehler
2*9	5	23			OFF	Eingabefehler
6*4	OFF	24	OFF			Eingabefehler
2*4	2	10			OFF	Eingabefehler
2968*64						
multiplication	carry (correct)	solution	carry (answer)	answer	new carry	result
8*6	OFF	48	OFF			Eingabefehler
6*6	4	40				Eingabefehler
9*6	4	58				Eingabefehler
2*6	5	17			OFF	Eingabefehler
8*4	OFF	32	OFF			Eingabefehler
6*4	3	27				Eingabefehler
9*4	2	38				Eingabefehler
2*4	3	11			OFF	Eingabefehler
795*49						
multiplication	carry (correct)	solution	carry (answer)	answer	new carry	result
5*4	OFF	20	OFF			Eingabefehler
9*4	2	38				Eingabefehler
7*4	3	31			OFF	Eingabefehler
5*9	OFF	45	OFF			Eingabefehler
9*9	4	85				Eingabefehler
7*9	8	71			OFF	Eingabefehler

*Figure 8: Input errors of a pupil*

## CONCLUSION

With the help of learning analytics technologies learners and teachers can be supported in education and especially in mathematics lessons. Pupils can train in different skills and they are able to calculate calculations as many as they want, because the trainers do not stop giving exercises. Teachers are able to support pupils with the analytics of learning technologies. It is very easy to recognise individual calculation errors with the help of the statistics.

Teachers can save time in lessons comparing the homework too. When learning analytics applications are used in education teachers have to be in the know about the skills and the experience of pupils in using computers. Depending on these skills pupils can have troubles with learning analytics technologies.

Based on the results and the determined data of the study, the following conclusion can be made:

- There is no gap between the learning progress of pupils who use learning analytical applications and the learning progress of pupils who work with traditional exercise sheets.
- The learning progress at the beginning of the secondary school is in multiplication and division higher than in addition and subtraction.
- With the help of learning analytical applications teachers are able to detect individual errors.
- Using mathematics trainers the teacher can save time in lessons comparing the homework.
- Learning analytical applications lessons could be designed with greater variety.
- For training of textual problems it is recommendable the combination of learning analytical applications and traditional training methods.
- Talented pupils calculate more calculations as required.
- Depending on skills and experience in using computers, working with learning analytical applications is easy or difficult.

More research studies are necessary to study the efficiency of learning analytical applications. Nevertheless this first field study pointed out that teachers as well as children had numerous benefits in their daily teaching and learning behaviour.

## REFERENCES

- Brinkman, W.P., Payne, A., & Underwood, J. (2008). HCI for Technology Enhanced Learning. In the *BCS-HCI '08 Proceedings of the 22nd British HCI Group Annual Conference on People and Computers: Culture, Creativity, Interaction - Volume2* (pp. 185-186). Swinton: British Computer Society.
- Carroll, W. M. (1994). Using worked examples as an instructional support in the algebra classroom. *Journal of Educational Psychology*, 86,(3), 360-367.
- Clow, D. (2011). *Doug Clow's Imaginatively-titled Blog: New Technology in Higher Education*. <http://dougclow.org/2011/02/28/the-learning-analytics-cycle/> (last visited March 2015)
- Ebner, M.& Schön, M. (2013) Why Learning Analytics in Primary Education Matters!. In the *Bulletin of the Technical Committee on Learning Technology*, Karagiannidis, C. & Graf, S (Ed.), 15(2), 14-17
- Ebner, M., Schönhart, J. & Schön, S. (2014a). Experiences with iPads in primary schools. In the *Profesorado*, 18(3), 161-173.
- Ebner, M., Schön, M., Taraghi, B., & Steyrer, M. (2014b) Teachers little helper: multi-math-coach. *IADIS International Journal on WWW/Internet*, 11(3), 1-12.
- Ebner, M., Schön, M., & Neuhold, B. (2014c). Learning analytics in basic math education – first results from the field. *e-Learning Papers*, 36, 24-27
- Erpenbeck, J., & Sauter, W. (2013). *So werden wir lernen!* Berlin Heidelberg: Springer Gabler.
- Frangenberg, H. (2014). Für jeden Kölner Schüler ein iPad. *Kölner Stadt-Anzeiger*. <http://www.ksta.de/koeln/neues-konzept-fuer-schulen-fuer-jeden-koelner-schueler-ein-ipad,15187530,28831496.html>. (last visited March 2015)

- Greller, W., & Drachsler, H. (2012). Translating learning into numbers: A generic framework for learning analytics. *Educational Technology & Society*, 15(3), 42-57
- Hugger, K.-U., & Walber, M. (2010). *Digitale Lernwelten: Konzepte, Beispiele und Perspektiven*. (Walber Markus, Hrsg.) Wiesbaden: VS Verlag für Sozialwissenschaften.
- Long, P., & Siemens, G. (2011) Penetrating the Fog: Analytics in Learning and Education. *EDUCAUSE Review Magazine*, 46/5, 31-40.  
<http://www.educause.edu/EDUCAUSE+Review/EDUCAUSEReviewMagazineVolume46/PenetratingtheFogAnalyticsinLe/235017> (last visited March 2015)
- Mavani, M. (2010). Blending intelligent and reciprocal tutoring systems: a dynamic approach. In the *Proceedings of the International Conference and Workshop on Emerging Trends in Technology* (pp. 704-707). New York, NY: ACM.
- Pruscha, H. (2006). *Statistisches Methodenbuch*. (H. Dette, & W. Härdle, Hrsg.) Berlin Heidelberg: Springer-Verlag.
- Scherer, P., & Moser Opitz, E. (2010). *Fördern im Mathematikunterricht der Primarstufe*. Heidelberg: Spektrum Akademischer Verlag.
- Schlag, B. (2013). *Lern-und Leistungsmotivation* (4. Ausg.). Wiesbaden: Springer.
- Vollrath, H.J., & Roth, J. (2012). *Grundlagen des Mathematikunterrichts in der Sekundarstufe* (2. Ausg.). Heidelberg: Spektrum Akademischer Verlag.
- www.bmbf.at. (19. Februar 2015c). *Lehrpläne der Allgemein bildenden Schulen: Lehrplan Mathematik AHS Unterstufe*. [https://www.bmbf.gv.at/schulen/unterricht/lp/ahs14\\_789.pdf?4dzgm2](https://www.bmbf.gv.at/schulen/unterricht/lp/ahs14_789.pdf?4dzgm2). (last visited March 2015)
- www.bmbf.at. (19. Februar 2015d). *Lehrpläne der Allgemein bildenden Schulen: Lehrplan Volksschule*. [https://www.bmbf.gv.at/schulen/unterricht/lp/lp\\_vs\\_gesamt\\_14055.pdf?4dzgm2](https://www.bmbf.gv.at/schulen/unterricht/lp/lp_vs_gesamt_14055.pdf?4dzgm2). (last visited March 2015)
- Yang, F.J. (2010). The ideology of intelligent tutoring systems. *ACM Inroads*, 63-65.