

# Single Phase Series Active For Aircraft Applications

Mohamad H Taha\*‡

\*Department of Electrical and Computer Engineering, College of Engineering Rafik Hariri University, Chouf 2010 Lebanon  
tahamh@rhu.edu.lb

‡ Corresponding author; Mohamad H Taha, Department of Electrical and Computer Engineering, College of Engineering Rafik Hariri University, Chouf 2010 Lebanon, tahamh@rhu.edu.lb

*Received: 04.06.2015 Accepted: 16.06.2015*

**Abstract-**The new electric power technology for modern aircraft is based on variable frequency generators typically ranges from 360 Hz at low speed to 800 Hz at high speed. Modern aircraft electric systems, including novel electrical distribution architectures, network interactions, protection, wiring and load management should be designed to operate with variable frequency source. Modern aircraft technology is moving toward what is known as More Electric Aircraft (MEA), this aims to increase the electrical power equipment rather than mechanical or hydraulic equipment. Power Electronics and motors drives are the major MEA components, these could produce harmonics on line current with poor power factor. This paper presents an analytical method of calculating reactive and harmonic current and using this current as a reference to feed a series active filter to compensate the harmonic currents generated by a nonlinear load.

**Keywords** Series active power filters (APF), harmonic and reactive current, more electric aircraft (MEA), variable frequency source.

## 1. Introduction

Aircraft nonlinear load such as rectifier circuit could have very bad effect on the other aircraft electric systems. This could cause current distortion and serious problems on electrical equipment such as:

1. Improper responding, interferences and degradation of the performance of devices or equipment.
2. Overheating and premature aging of the electric devices.

The new power electronics technology could eliminate these problems and make the electric system more efficient with high power density.

MEA loads will be designed to operate with variable frequency supply, usually from 360 to 800 Hz approximately, although there are some electrical loads that may require a DC supply or a traditional fixed frequency supply (400 Hz). Sophisticated electrical systems are usually multiple voltage systems using a combination of AC and DC buses to power various aircraft components. Figure 1 shows a block diagram for aircraft power system [1,2]. Here depending on the type of the load, the input supply could feed variable frequency load, fixed frequency load or DC load. However, as one essential part of the MEA electric systems are the AC/DC converters which are connected to a variable frequency AC bus and used to supply DC power for different loads. These converters are required to show

low volume, high reliability, and low current harmonics. The current harmonics will cause distortion in the line impedance and the terminal voltage of the load will be distorted. If linear loads are connected to the system they will absorb the distorted current which could cause serious problems on the system. A traditional and simple method to overcome and solve these problems is to use passive filters; however, as it is well known these types of filters operate at specified frequency, which means many filters should be tuned to cancel harmonics at different frequencies. Furthermore, resonances can occur, and the electrical system can start to operate with capacitive power factor [3,4].

In More Electric Aircraft, the power electronics technology represents a challenge for aeronautical application, which enhances power quality problems even at the lowest voltage level in distribution system. In recent technology, active filters have been widely used in to improve the power quality for More Electric Aircrafts. Good numbers of different active filters have been designed with a limited emphasis on single phase system.

This paper presents a control method for a series active power filter (APF) by using an analytical method of calculating the active and non-active and harmonics current and power for non-sinusoidal load current. The voltage injected by the series active filter is proportional to the harmonics and reactive components of the load current. [1,3].

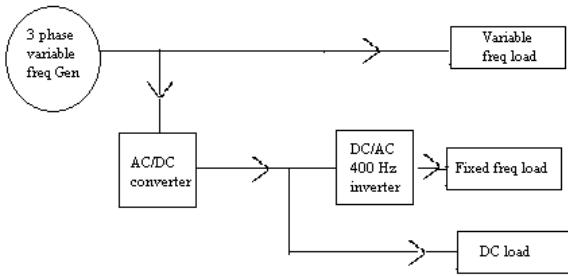

**Fig. 1.** Aircraft power system

The APF must comply with the regulations and standards of the aircraft power system such that:

1. The harmonics on the input current should be low and meet the required values.
2. Minimizing reactive power components that could be achieved by high input power factor.
3. Maximizing power density in order to minimize the weight. [1,2]

However, due to the wide ranging nature of the load and supply frequency variation, the design of this system poses significant challenges.

Furthermore, the choice of the hardware components such as semiconductor devices, capacitors, inductors and resistors is very important for aerospace industry. These components have to be selected so that normal service maintenance would ensure the retention of their specified characteristics through the full range of operational and environmental conditions likely to be encountered through the life of the aircraft, or support facility, in which they are installed. [1]

## 2. Power Calculation

Instantaneous active power is defined as the rate of change of the transfer or utilization of the energy generation. It is a physical quantity and satisfies the principles of conservation of energy.

Normally in the electric power system applications the voltage and current could be represented by:

$$v(t) = \sqrt{2} V_{rms} \sin \omega t \tag{1}$$

A sinusoidal current given by:

$$i(t) = \sqrt{2} I_{rms} \sin(\omega t - \varphi). \tag{2}$$

The instantaneous power is the multiplication of the instantaneous voltage and current signals which is divided into two components namely the instantaneous active power and the instantaneous reactive power :

$$p(t) = v(t)i(t) = p_a + p_q \tag{3}$$

The active power is the time average of the instantaneous power over one periode of wave p(t):

$$P = \frac{1}{T} \int_0^T v(t)i(t)dt \tag{4}$$

Instantaneous reactive power is produced by the reactive components of the current and the related energy component oscillates between the source and the load where the net transfer energy to the load is zero. Furthermore reactive power can be thought of as the useless power that causes increased line current and losses.

When a nonlinear load is connected, the system no longer operates in sinusoidal condition due to the presence of the harmonics; in this case Fourier series is used to express the voltage and current [5,6,7]:

$$v(t) = V_0 + \sum_{n=1}^{\infty} \sqrt{2} V_{n,rms} \sin(n\omega t) \tag{5}$$

$$i(t) = I_0 + \sum_{n=1}^{\infty} \sqrt{2} I_{n,rms} \sin(n\omega t - \varphi_n) \tag{6}$$

Where,  $V_0$  and  $I_0$  represent DC value;  $V_{n,rms}$  and  $I_{n,rms}$  represent RMS value for the nth harmonic and  $\varphi_n$  represent phase between the voltage and current for the nth harmonic.

By assuming the DC voltage and current quantities equal to zero, the average active power is (8.9.10):

$$P = \sum_{n=1}^{\infty} I_{n,rms} V_{n,rms} \cos(\varphi_n) \tag{7}$$

The nonsinusoidal single phase periodic voltage and current waveforms have two distinct components, the fundamental components and harmonics components bear in mind assuming the DC quantities for both voltage and current are zero.

$$i(t) = i_1(t) + i_h(t) \tag{8}$$

$$v(t) = v_1(t) + v_h(t) \tag{9}$$

$$v_1(t) = \sqrt{2} V_{rms} \sin(\omega t) \tag{10}$$

$$i_1(t) = \sqrt{2} I_{rms} \sin(\omega t - \varphi_1) \tag{11}$$

$$v_h(t) = \sum_{n \neq 1}^{\infty} \sqrt{2} V_{n,rms} \sin(n\omega t) \tag{12}$$

$$i_h(t) = \sum_{n \neq 1}^{\infty} \sqrt{2} I_{n,rms} \sin(n\omega t - \varphi_n) \tag{13}$$

In the IEEE Standard for non-sinusoidal voltage and current, the active power definition is the same as given in the equation (4) and :

$$P = P_1 + P_h \tag{14}$$

$$P_{11} = V_1 I_1 \cos \varphi_1 \tag{15}$$

$$P_h = P - P_1 = \sum_{n \neq 1}^{\infty} I_{n,rms} V_{n,rms} \cos(\varphi_n) \tag{16}$$

Similarly, the reactive power can be represented:

$$Q = Q_1 + Q_h \tag{17}$$

Fundamental reactive power :

$$Q_{11} = V_1 I_1 \sin \varphi_1 \tag{18}$$

$$Q_h = Q - Q_I = \sum_{n \neq 1}^{\infty} I_{n,rms} V_{n,rms} \sin(\varphi_n) \quad (19)$$

Therefore the apparent power S is the sum of the fundamental and non-fundamental term:

Fundamental apparent power :

$$S_{I1} = V_I I_I = \sqrt{P_{11}^2 + Q_{11}^2} \quad (20)$$

Total apparent power:

$$S^2 = (VI)^2 = (V_I I_I)^2 + (V_I I_h)^2 + (V_h I_I)^2 + (V_h I_h)^2 \quad (21)$$

$$S^2 = S_I^2 + S_N^2 \quad (22)$$

$$S_I^2 = (V_I I_I)^2 = P_I^2 + Q \quad (23)$$

$$S_N^2 = (V_I I_h)^2 + (V_h I_I)^2 + (V_h I_h)^2 \quad (24)$$

As well known the total harmonic distortion for both voltage and current is defined as the ratio between rms value of harmonics to fundamental component:

$$THD_V = \frac{V_h}{V_I} \quad (25)$$

$$THD_I = \frac{I_h}{I_{I1}} \quad (26)$$

The distortion power factor due to the harmonic current is:

$$D_I = V_I I_h = S_I(THD_I) \quad (27)$$

The distortion power factor due to the harmonic voltage is:

$$D_V = V_h I_I = S_I(THD_V) \quad (28)$$

Harmonic apparent power

$$S_h = V_h I_h = S_I(THD_I)(THD_V) \quad (29)$$

Harmonic distortion power :

$$D_h = \sqrt{S_h^2 - P_h^2} \quad (30)$$

Apparent power becomes

$$S^2 = (VI)^2 = (S_{I1})^2 + (D_I)^2 + (D_V)^2 + (S_h)^2 \quad (31)$$

Nonfundamental apparent power:

$$S_N^2 = S^2 - S_I^2 = D_I^2 + D_V^2 + S_h^2 \quad (32)$$

Nonactive power :

$$N = \sqrt{S^2 - P^2} \quad (33)$$

The power factor of a sinusoidal AC system is equal to the cosine of the angle between the current and the voltage. This angle is called the displacement angle (power factor =  $\cos \varphi$ ). However, a rectifier draws a non-sinusoidal current from the AC system and the value  $\cos \varphi$  does not represent the power factor.

$$P.F = \frac{\text{Active power}}{V_{rms} I_{rms}} \quad (34)$$

The current contains harmonic components which result in an RMS value higher than the RMS value of its fundamental component. Thus, the power factor is less than the cosine of the displacement angle.

If the supply voltage of the rectifier is considered to be sinusoidal and consequently the mean power is:

$$P_{active} = V_{rms} I_{1rms} \cos \varphi_1 \quad (35)$$

Where the suffix 1 relates to the fundamental component of the current and  $\varphi_1$  is the phase angle between the voltage and the fundamental component of the current.

Therefore:

$$P.F = \frac{I_{1rms}}{I_{rms}} \cos \varphi_1 \quad (36)$$

Where,

$\frac{I_{1rms}}{I_{rms}}$  is defined as the input distortion factor,

$\cos \varphi_1$  is the input displacement factor.

Assume the input voltage is sinusoidal and has no distortion and the input current, which is distorted by the power factor and harmonics of the load, therefore the load current made up with the following terms:

$$i_L(t) = i_o(t) + i_a(t) + i_r(t) + i_h(t) \quad (37)$$

Where,

- $i_o(t)$  Dc component
- $i_a(t)$  Active current
- $i_r(t)$  Reactive current
- $i_h(t)$  Harmonic current

Equation (37) can be simplified by combining the reactive and harmonic currents and by assuming the dc component of the load current is zero because in practice this current is usually small or does not exist.

$$i_{rh}(t) = i_r(t) + i_h(t) \quad (38)$$

The harmonic and reactive current drawn by the load is extracted from the load current is given by:

$$i_{rh}(t) = i_L(t) - i_a(t) \quad (39)$$

By applying a low pass filter to the instantaneous load power the average active power can be obtained. Hence the instantaneous active current is:

$$i_a(t) = \frac{\sqrt{2}}{v_{rms}} p_{av} \times \sin \omega t \quad (40)$$

Combine equations (38), (39) and (40):

$$irh = il - \frac{\sqrt{2}}{vrms} p_{av} \times \sin\omega t \tag{41}$$

To generate the reference current, the harmonic and reactive current drawn by the load is extracted from the load. Furthermore the voltage injected by the series active filter is proportional to the harmonic and reactive component of load current. Therefore :

$$V_{refer} = K (irh) \tag{42}$$

$V_{refe}$  is compared with the voltage injected from the active filter and a PI controller is used to control the PWM in turn control the power compensation to the load [11,12,13].

Figure 2 shows the APF circuit diagram and figure 3 control strategy of the series filter. The output stage of the diode rectifier could be connected to a DC or to 400 Hz inverter (Single or 3 phase inverter). In this case the system will be operated as variable to constant frequency inverter.

### 3. Simulation Results

Simulation has been done at different input frequency and different componsation ratio. The diode rectifier is connected to a resistive load, in this case the system will be used to feed DC load. Results are show in figures 4 to 17. It can be seen with good compensation, the power factor is unity and THD of the input current equal to 7%, with poor compensation the system operates with bad power factor and THD of the input current is high. The parameter values used for the simulation are shown in table 1.

**Table 1.** Simulation parameters.

RMS phase voltage	115 V
Input inductance , L1,2,3	L = 200uH
Dc Output capacitor	$C_{dc} = 500\mu F$
Active filter capacitor	C = 500μF
Load	R = 1 Ω
Compensation ratio	K = 10
Switching frequency	20 KHz

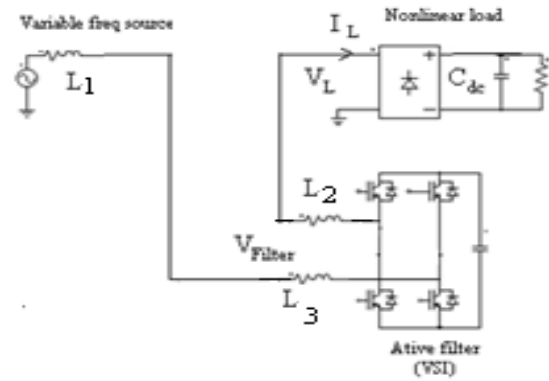

**Fig. 2.** Active filter circuit.

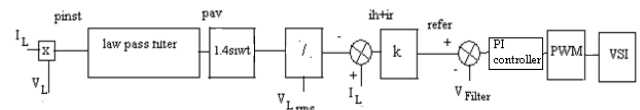

**Fig. 3.** Control strategy for the active filter.

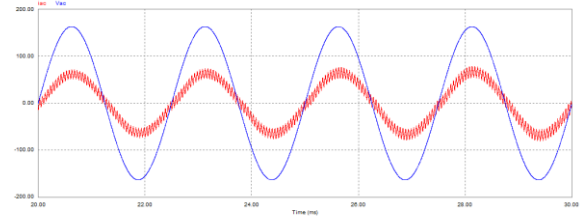

**Fig. 4.** Simulation results for 400 Hz input voltage and k=10 showing input voltage and current.

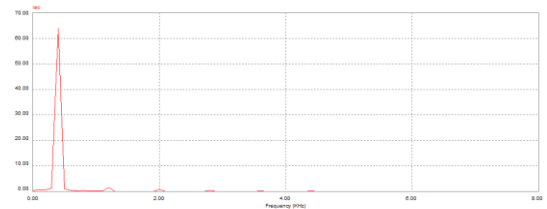

**Fig. 5.** Simulation results for 400 Hz input voltage and k =10 showing FFT for the input current. (THD = 7%)

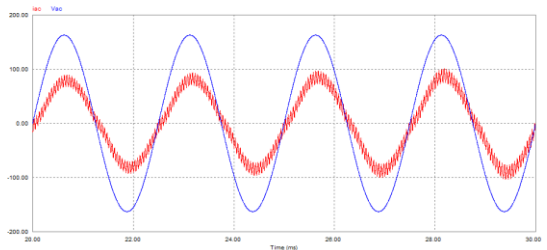

**Fig. 6.** Simulation results for 400 Hz input voltage and k = 5 showing input voltage and current.

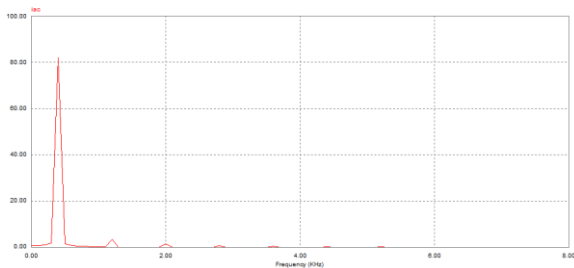

**Fig. 7.** Simulation results for 400 Hz input voltage and  $k = 5$  showing FFT for the input current. (THD = 11%)

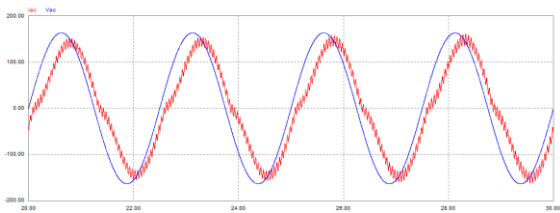

**Fig. 8.** Simulation results for 400 Hz input voltage and  $k = 1$  showing input voltage and current.

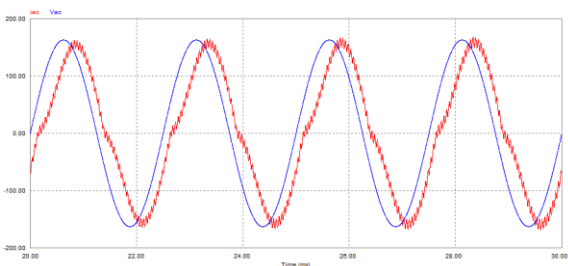

**Fig. 9.** Simulation results for 400 Hz input voltage and  $k=0.5$  showing input voltage and current.

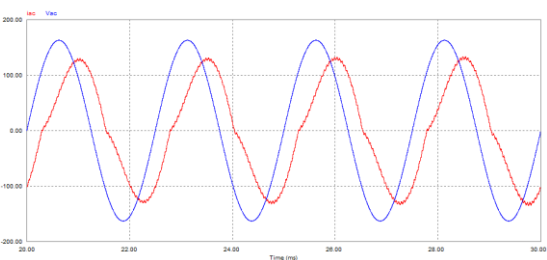

**Fig. 10.** Simulation results for 400 Hz input voltage and  $k=0.1$  showing input voltage and current.

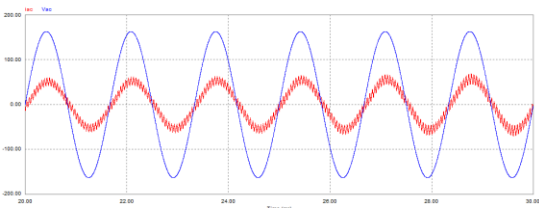

**Fig. 11.** Simulation results for 600 Hz input voltage and  $k=10$  showing input voltage and current.

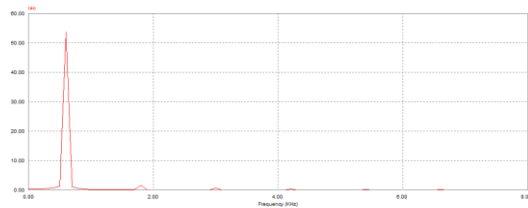

**Fig. 12.** Simulation results for 600 Hz input voltage and  $k=10$  showing FFT for the input current. (THD = 7%)

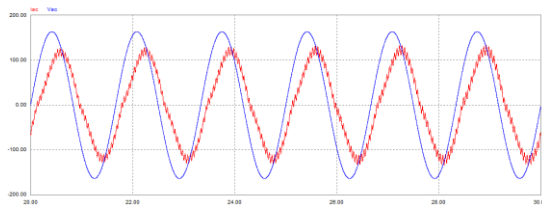

**Fig. 13.** Simulation results for 600 Hz input voltage and  $k=1$  showing input voltage and current.

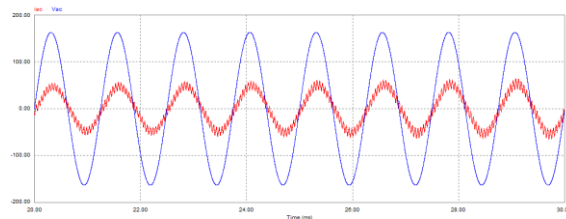

**Fig. 14.** Simulation results for 800 Hz input voltage and  $k=10$  showing input voltage and current.

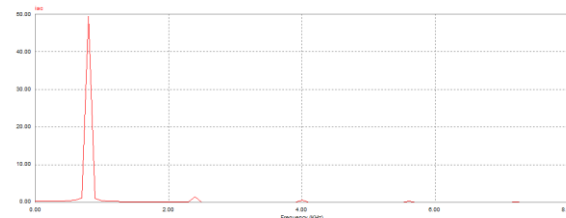

**Fig. 15.** Simulation results for 800 Hz input voltage and  $k=10$  showing FFT for the input current. (THD = 7%)

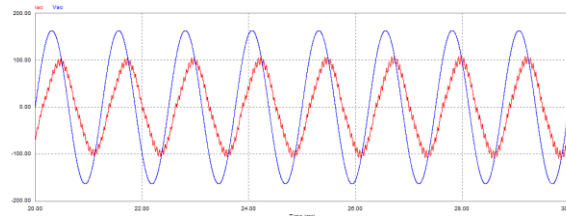

**Fig. 16.** Simulation results for 800 Hz input voltage and  $k=1$  showing input voltage and current.

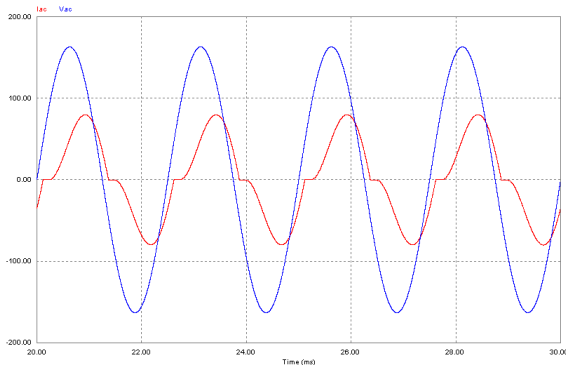

**Fig.17.** Simulation results for 400 Hz input voltage showing input voltage and current for  $K=0.5$

#### 4. Conclusion

In this paper a simple control strategy for single phase active filter y has been proposed. The system could be used in MEA to feed DC load from variable input source frequency.

The proposed active filter injects series voltage proportional to the sum of the harmonic and reactive current drawn by the nonlinear load. The simulation gave very encouraging results and shows that when the compensation ratio is low, high distortion appears on the input current and the power factor is not unity

Furthermore, this paper presents the definition and calculation of active and reactive power and power factor for sinusoidal and non-sinusoidal sources.

#### Acknowledgements

I would like to express my sincere appreciation and respect to the late prime minister Rafik Hariri who is entirely responsible for funding my studies in England.

#### References

[1] M H Taha, "Active rectifier using DQ control for aircraft application" IEMDC 2007; PP 1306-1310.  
 [2] M H Taha, S Skinner, S Gami, M Holme and G Raimondi " Variable frequency to constant frequency converter for aircraft application" PEMD 2002, PP235-240  
 [3] Kamala Kant Mishra, Rajesh Gupta, " Load compensation for single phase using series active filter" IJEST Vol 3, No 3 , 2011 , pp 83-93  
 [4] J. Sebastian Tepper, Juan W. Dixon," A simple frequency – independent method for calculating the reactive and harmonics current in nonlinear load" IEEE Trans on Indust Elect, Vol. 43 No.6 Decem 1996. Pp 647-65

[5] Marko Dimitrijevic and Vanco Litovski " Quantitative Analysis of reactive power calculation for small non-linear load" Proceeding of small system simulation symposium 2012, Nis  
 [6] Juan Dixon, Luis Morán, José Rodríguez, Ricardo Domke, "Reactive Power Compensation Technologies, State-of-the-Art Review", IEEE Proc. vol. 93, no. 12, pp. 2144-2164, 2005.  
 [7] R. S. Herrera, P. Salmeron, and H. Kim, "Instantaneous reactive power theory applied to active power filter compensation: Different approaches, assessment, and experimental results", IEEE Trans. Ind. Electron., vol. 55, no. 1, pp. 184–196, Jan. 2008.  
 [8] Kahraman Yumak, Omer Usta " A Controversial Issue: Power Components in Nonsinusoidal Single-Phase Systems", ELECO 2011 7th International Conference on Electrical and Electronic Engineering, 1-4 December, BURSA, Turkey, pp 158-162, 2011  
 [9] A. E. EMANUEL, "Summary of IEEE Standard 1459: Definition for Measurement of Electric Power Quantities Under Sinusoidal, Nonsinusoidal, Balanced, or Unbalanced Conditions" IEEE Trans Ind Appl., vol. 40, no 3, pp869-878, May/jun, 2004  
 [10] A, E, Emanuel, " Power Definitions and the physical Mechanism of power flow", John Wiley & Sons Ltd, UK 2010  
 [11] L. Hongda and K. Cao, "Active power filter simulation based on instantaneous reactive power theory and the PWM hysteresis control mode", 978-1-4244-8161-3/11/ IEEE, 2011.  
 [12] Roger C. Dugan, Mark F. McGranaghan, Surya Santoso and H. Wayne Beaty, "Electrical Power Systems Quality", 2nd edition, McGraw-Hill Companies ,2004.  
 [13] J. L. Afonso, H. R. Silva and J. S. Martins, "Active Filters for Power Quality Improvement", IEEE Porto Power Tech'2001, Porto, Portugal, 10-13 Set.