

İNSAN BİLDİRİŞİMİYLE İLGİLİ ÜÇ TEORİNİN TAHLİL ve TENKİDİ

A REVIEW OF CURRENT THEORIES CONCERNING HUMAN COMMUNICATION

By

D. CÜCELOĞLU

Institute of Experimental Psychology, University of Istanbul.

Bildirişim vetireleri değişik seviyelerde çeşitli açılardan tetkik edilmiştir. Bir psikolog, veya bir biyolog kadar bir matematikçi de bu vetirelerle ilgilenir. Şimdiki yazıda insan bildirişimine yaklaşış tarzlarından üçü ele alınıp «mediation» teorisi çerçevesi dahilinde mahiyetleri ve birbirleriyle münasebetleri yönünden incelenecektir. I. Malûmat Teorisi, II. Lenguistik Teori, ve III. Davranışçı Teorilerden bu yazıda sadece ilk ikisi ele alınmıştır. Davranışçı Teori bu derginin gelecek sayısında tartışılacaktır.

Communication processes have been studied at various levels from different standpoints. A mathematician has an interest in them as much as a psychologist, or a biologist. This paper attempts to take three current approaches to human communication within the framework of the mediation theory and discuss their nature and relations to each other in the given mediation-integration model. These theories are I. Information Theory, II. Linguistic Theory, and III. Behavior Theory. In the present article only two of them will be discussed; Behavior Theory will be taken in the next issue of this journal.

The object of this paper is to study some of the theoretical issues of information Theory, Linguistic Theory, and Behavior Theory as applied to a human communication model based on Osgood's integration-mediation learning approach (Osgood, 1957). We will consider (i) the nature of these theories, (ii) their contribution to the understanding of human communication, and (iii) some critical issues involved in them.

The model represented in Figure 1 is given in a definite environment (W) which contains the physical, the social, and the psychological context in which communication takes place. Channel (C) and message (M) are well

known components of classic communication models (Shannon and Weaver, 1949). Source of noise (SN) represents the source of processes which interfere with (M) and distort it. Both of the sensory recoding (SR) and receiver (R) components function in the same way under the same principles. The nature of inner components, i. e., integration processes (Igr), and Intention (I) will be discussed later while considering Behavior Theory.

I. INFORMATION THEORY

I-i. The Nature of the Theory

Information Theory (I. T.) is a special form of general statistical theory and employs the concepts of probability theory. It can be used both for descriptive and inferential purposes. The theory is interested in describing the message in probability terms for an engineering point of view, but the outcome of the applications of the theory can be employed in studying human behavior.

Maximum uncertainty¹ is defined as the logarithm base 2 of the number of choices, and expressed in terms of bits. Relative uncertainty (or entropy, or freedom of choice) of a system is defined as the ratio of the actual to the maximum uncertainty. Redundancy of a source is defined as **1 - relative uncertainty**. In the case of two independent systems I and J the amount of **joint uncertainty** will be equal to the sum of uncertainties of the two systems alone.

- (a) Symbols qualitatively must belong to the same class.
- (b) Alternatives must be mutually exclusive.
- (c) Alternatives must have identifiable recurrence.

These requirements can be fulfilled by a very large variety of systems, and therefore I.T. can be applied to systems of all kinds.

I—ii. The Contribution of I. T. to the Understanding of Human Communication

1. Shannon and Weaver use the term «Information» where we use «Uncertainty». This change in terminology is employed by Osgood and Wilson (1960) and we depend on the same line of reasoning they used. Thus, «uncertainty» will be used instead of «information» and «information» will be used for the reduction of «uncertainty».

In his review of Shannon's formulation of I. T. Weaver (1949) examines the communication processes at three levels. The first level corresponds to the technical problem, i. e., how accurately can the symbols of communication be transmitted? He identifies the second level as semantic level which is concerned with the question «how precisely do the transmitted symbols convey the desired meaning?», and the third level deals with the question of effectiveness «how effectively does the received meaning affect conduct in the desired way?» Weaver expresses the idea that I. T. is interested in the first level, but since the accomplishment of the second and the third level depends on success at the first level, the mathematical theory of communication has powerful implications for the communication process as a whole.

The amount of publication taken as a measure of the contribution of I. T. to the understanding of human communication is of considerable in size (see Quastler, 1955; Luce, 1960; Herdan, 1956; Pierce, 1961; Cherry, 1961), but since the interest of this paper is to point the critical issues involved in the theory and discuss the significance of the contributions made to the understanding of human communication, we will not attempt to outline or to enumerate points of view which have been taken till now.

Some of the contributions of I. T. to the understanding of human communication can be briefly mentioned as in the following: First of all the name of the theory caused lengthy discussions on the concept of information and thus helped to clarify the existence of at least two kinds of information: **semantic information and structural information**. I. T. supplies ways of measuring structural information (uncertainty) and thus clarifies many concepts used in human communication such as amount of information transmitted, the measurement of independency between the two sources, the measurement of redundancy, etc. Besides these contributions, I. T. brought a clear definition of noise, channel capacity, and coding processes. With the clarification of these concepts some of the problems of psychology especially in the area of perception and psychophysics could be stated more clearly, and some obscure notions became clearly manageable (Attneave, 1959).

I-iii Some Critical Issues of I. T.

Is I. T. a scientific theory? If it is a scientific theory what is the subject matter and what are the predictions of this theory? These are the

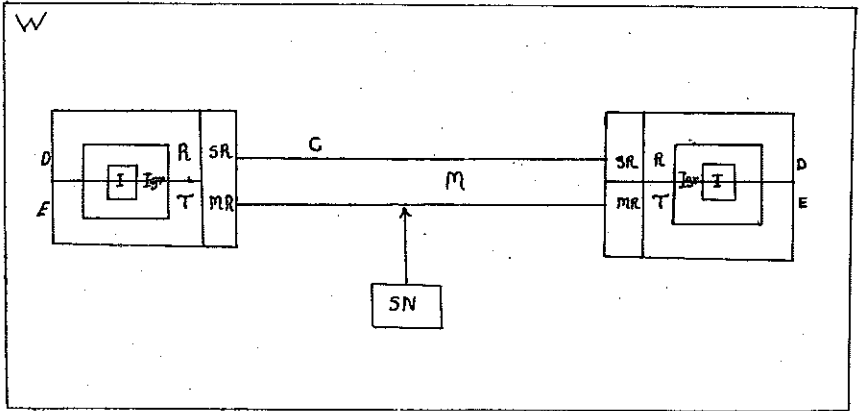

Figure 1. A model of human communication based on the mediation-integration approach. W: environment; D: decoding; C: channel; E: encoding; SR: sensory recoding; MR: motor recoding; R: receiver; T: transmitter; Igr: integration processes; I: intention (significance) process; M: message.

kind of questions that I. T. answers in non-affirmative way. The mathematical theory of communication is not a scientific theory, neither in the sense of Isaac Newton's gravity theory nor of Charles Darwin's theory of evolution, because it does not predict or claim anything as far as communication goes except the idea of channel capacity. The capacity of a channel which carries signals is predictable under I. T. and has important implications in communication engineering.

I. T. is another statistical device which is applicable to a range of problems, some of which can not be properly dealt with using other statistical measures. Thus any general statement about the validity of I. T. is destined to be more or less meaningless if the particular problem is not specified. As it is pointed out somewhere else (Attneave, 1959) some psychophysical and perception problems could be stated with more accuracy and efficiency in I. T. notions with parallel usage of behavioristic terms. Until now there hasn't been any major criticism against the employment of I. T. notions in Psychology.

On the other hand the employment of I. T. terms in describing and inferring the nature of human languages raised some controversial issues. As far as we know there is no disagreement on the matter that natural languages have a structure and this can be described in terms of I. T.

notions. It seems that it is generally agreed that any system which is ergodic can be described in terms of I. T. notions. But the area of disagreement seems to be one of inferential power, namely, can I. T. infer the inherent constitution of the system under discussion? Ashby thinks that this question can be answered in either way depending on the nature of the question. Obviously the investigator's understanding of the nature of the question can differ from one investigator to another and this difference in understanding the nature of the subject matter can lead to the employment of different techniques of inquiry.

One of these controversial issues occurs in the employment of I. T. notions concerning the inherent characteristics of language. The idea that a natural language can be taken as a Markov system and can be generated by a finite state machine is expressed explicitly (Osgood and Wilson, 1960; Pierce, 1961; Herdan, 1956; or implicitly (Wiener, 1954) by many investigators in the field and the main emphasis is put on the concentration of strategy of the investigation. Nth-order approaches to language (Shannon and Weaver, 1949) are only one example of the applications of this general strategy.

This strategy and the application of this strategy to human languages is rejected by Noam Chomsky (Chomsky, 1957) on the following grounds:

(a) «Grammaticalness in English» and «high order of statistical approximation to English» cannot be identified. He gives two sequences of English words, where (1) is grammatical inspite of being meaningless, (2) is neither grammatical nor meaningful.

- (1) Colorless green ideas sleep furiously.
- (2) Furiously sleep ideas green colorless.

«It is fair to assume that neither sentence (1) nor (2)... has ever occurred in an English discourse. Hence, in any statistical model for grammaticalness, these sentences will be ruled out on identical grounds as equally more remote from English. Yet (1) though nonsensical, is grammatical, while (2) is not (Chomsky, 1957, p. 16)».

(b) English is not a finite state language, thus cannot be represented by Markov processes. This conclusion is reached on the basis of evidence that the English language contains center-embeddings of various sorts and thus any system which lacks the potentiality for recursive devices cannot be the base for a grammer of the English language.

(c) «If a grammar of the Markovian type produces all English sentences, it will produce many non-sentences as well. If it produces only English sentences, we can be sure that there will be an infinite number of true sentences, false sentences, reasonable questions, etc., which it simply will not produce (Chomsky, 1957, p. 24)».

Osgood (1966) claims that grammar involves high Markov processes at P-Marker level as well as at terminal string level. He finds evidences in English hesitation phenomena (Maclay and Osgood, 1959). The only point not completely clear in Osgood's discussion of transformation grammar versus Markovian processes is that a Markovian system operates on a finite number of states and could not produce self-embeddings, which is Chomsky's basic claim. Since it was shown, however, that English grammar makes use of recursive devices, the alternative mechanism available to this system for dealing with this phenomenon might be clarified.

Before we go into the discussion of the nature of linguistic theory let us summarize the nature of I. T. in terms of our communication model in Figure 1. I. T. can give us a clear description of (M) structure and also a

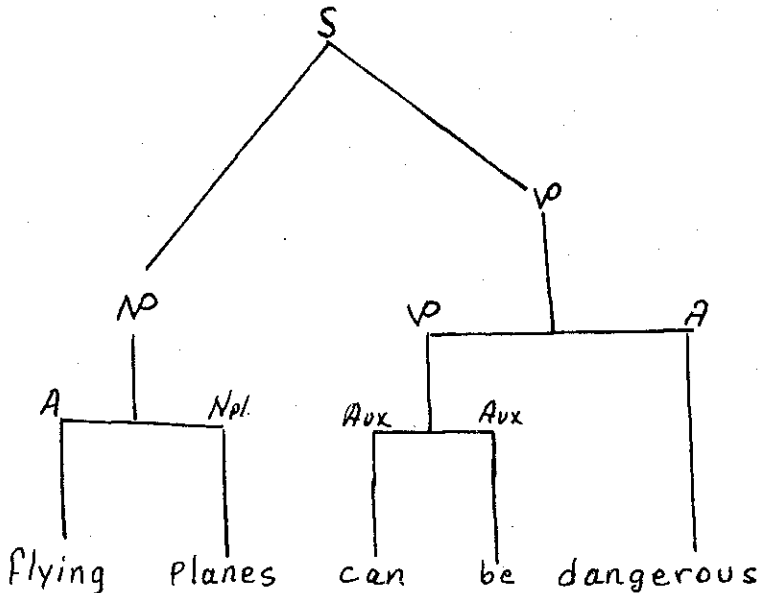

Figure 2. Representation of the structure of the sentence «Flying planes can be dangerous»!

device for measuring the capacity of (C), which in fact gives upper and lower boundaries of (SR) and (MR), and these are all vital for communication processes. The measure of noise and fidelity taken together can give us a reliable measure of the capacity and limits of (SR), (R), (T), and (MR), if they are taken together with the measurement of channel capacity. These implications of I. T. have the utmost importance for communication processes, and thus should be given first consideration. In our daily communication we rarely become aware of the structural nature of messages and of the limitation of the components (SR), (R), (T), (MR), and (C); thus we rarely question their contribution to the general communication processes. But when we encounter pathological cases which may originate from a kind of malfunctioning at one of the levels of these components we become fully aware of their contribution to our communication. The relevance of I. T. to (Igr) component will be discussed while considering Behavior Theory.

II. LINGUISTIC THEORY

II-i. The Nature of the Theory

Linguistic theory can be considered as an investigation of the structure of (M) in our communication model, and its interest can be expanded to include (SR), (MR), and (R), (T), or sometimes (Igr), and in the most ambitious cases we see that even (I) is included in some levels of linguistic theory (Fodor and Katz, 1964, pp. 479-519).

Chomsky defines linguistic theory as a system of «hypotheses concerning the general features of human language put forth in an attempt to account for a certain range of linguistic phenomena, (in Fodor and Katz, 1964, p. 50). For him, a linguistic theory should consider the competence of the speaker, that is the ability to utter new sentences and to understand new utterances, as its central fact. A theory which deals with linguistic competence should contain syntactic, phonological, and semantic components.

The syntactic component generates strings of minimal syntactically functioning elements (or formatives) and specifies the categories, functions and structural interrelations of the formatives and systems of formatives. The phonological component converts a string of formatives of specified syntactic structures into a phonetic representation. The semantic component assigns interpretation to syntactically generated structure.

Every linguistic theory which deals with linguistic competence investigates these components at various levels of adequacy. We will briefly see later on what these levels are and in what degree they are satisfied by different theories; but before we go into that problem let us briefly see what are the nature of these components in two different schools of linguistics, i. e., taxonomic school and the transformational school.

The taxonomic model mainly emphasizes the procedural and descriptive approach, and thus can be considered as more interested in the study of (M), (SR), and (MR) in our communication model in Figure 1. It works with more concrete and more atomistic procedures. The rules of a taxonomic model can be called as context-sensitive rules because they conform the following type $\Phi A \psi \rightarrow \Phi W \psi$ which should be read as «rewrite element **A** as **W** in the environment of $\Phi - \psi$. It is interpreted as **A** has the member (variant, realization) **W** in the context $\Phi - \psi$. Taxonomic theory rules are context sensitive of the above kind and are unordered. These rules produces a derived P-marker of the strings of formatives, and this derivation involves only a single stage.

In the transformational school the syntactic component consists of constituent structure (CS) and transformational components. CS contains an ordered set of rewriting rules (context-sensitive) that generates base terminal strings, i. e., base P-markers. The transformational component consisted of a partially ordered set of rules which can be either context-sensitive or context-free in nature, and these rules operate on base P-markers yielding surface P-markers. T-rules which are applied on base P-markers are obligatory and optional in kind, and they constitute the derivational history of the surface P-markers.

The phonological component includes «an ordered set of rewriting rules, an ordered set of transformational rules, and an ordered set of rewriting rules in that order. The transformational rules, furthermore, apply in a cycle, first to the smallest constituents of strings, then to the next largest constituent, etc., until the maximum domain of phonological process is reached... this **transformational cycle** determines the phonetic form of syntactically complex units from the underlying (abstract) phonemic form of their components, using the manner of composition specified by the derived P-marker (Fodor and Katz, 1964, p. 54).»

Levels of Adequacy. One can observe three levels of adequacy in a linguistic theory: (1) Observational, (2) Descriptive, (3) Explanatory.

(1) The achievement of observational adequacy constitutes the lowest level of success for a grammar. This level requires only a correct presentation of the data. The main motivation of a grammar at this level is concerned merely to give an account of the primary observed data.

(2) Descriptive adequacy can be achieved if the grammar gives a correct account of the underlying regularities in the language behavior. At this level grammar is motivated to explore the nature of the linguistic intuition of the speaker.

(3) Explanatory adequacy is achieved by a grammar when that particular grammar gives an interpretation of the linguistic intuition of the native speaker. In other words at this level a grammar gives an account of its accomplishment at the descriptive level.

Observational adequacy is achieved by the taxonomic grammars, but the second and the third levels are not reached. Taxonomic grammar gives a P-marker for the sentence shown in Figure 2, but is not capable of giving an account of the ambiguity of the sentences, and is not also capable of indicating the origin of the ambiguity. On the other hand transformational grammar can satisfy the requirements of second level in terms of assigning two different transformational histories to the sentence :

- (1) The planes fly.
- (2) People fly planes.

II-ii. Contribution of Linguistic Theory to the Understanding of Human Communication

In this section first we will consider taxonomic grammar in terms of our communication model, and discuss some relevant problems that this particular linguistic theory presents in terms of human communication.

Taxonomic grammar meets the observational level of adequacy and thus mainly deals with (M), (SR), and (MR) in the communication model. (M) can be studied from phonological, syntactical, and semantical standpoints, and the taxonomic grammar confined itself to the study of (M) within these different points of view.

The study of sounds of linguistic utterances is known as phonetics. The phonetician can be interested in the sound-producing movements as well as resulting sound waves. If he develops an interest in the first area he

will concentrate mainly on the anatomical and the physiological aspects of (MR), on the other hand he may be interested in exploring the structure and function of (SR). Taxonomic grammar is interested in the sound structure of the linguistic utterance (M) at the level of observational adequacy. A strict description of the sound structure of the utterance is developed in terms of **distinctive features** (Bloomfield, 1933, p. 77) and the basis for these features are found in the structural and the functional constitution of (MR). Thus one can see the following reference points frequently used for description of sounds of an utterance : dorsum, center, blade, tip of tongue (articulators), velum, front and back velum, dome, alveolar ridge, teeth, lips, etc. One can also see that the taxonomic grammarian refers to (R), (T) and (Igr) components of the communication model given in Figure 1 to explain such notions as phoneme, allophone, morpheme, and allomorph. But stress on these components are as significant as in the case of the transformational grammarian.

The taxonomic grammar contains unordered syntax rules which are context sensitive. Through these rules this grammar generates a P-marker on a given string of words and thus fulfils the requirement of the observational level of adequacy. Syntax rules does not refer to (R), (T), (Igr) and (I) in the model, and the lack of interest in these components of the speaker-hearer prevents the grammar from achieving **descriptive** and **explanatory** levels. This, in our opinion, is the very characteristic of the taxonomic grammar that renders it unable of explaining such ambiguous sentences as the sentence represented in Figure 2.

The semantic component of this grammar again takes (M) as its primary interest field. The meaning is defined as «the distribution of a linguistic form», and the distribution is understood in terms of the (M) as being the text of utterances (Hockett, 1958, p. 174). According to this school a linguist should study the structural properties of the utterances (M), and since the processes which take place in (I), and (Igr) are represented in (M) linguist should concentrate his attention on (SR), (MR), and (M) components. Taxonomic grammar with its analytic procedure and empirical orientation developed rigorous methods to analyze linguistic utterances. Information theory was readily recognized as a tool by taxonomic grammarians and some attempt are made to combine the two approaches (Saporta, 1961, Pp. 44-67).

The striking difference between taxonomic and transformational gram-

mar's lies in their relative emphasis of the components of the communication model. The taxonomic school restricts itself mainly to (SR), (MR), and (M) components, whereas the transformational grammar extends to all components especially emphasizing (Igr) and (I). Transformational Linguistic theory's main concern is to explore the nature of the linguistic intuition of the speaker which is underlined by the regularities of rules of the utterances of the speaker. The speaker of a language is constantly creative (rule-governed creativity) (Foodor and Katz, 1964, P. 59) while he is uttering and understanding, i. e., while he is communicating. The concern of the linguist, in the transformational school is, to explore the nature of these rules which constitute the base of the linguistic intuition of the native speaker. The linguist will build a theory of that language (grammar) which will produce the native speaker's grammatical utterances and only those utterances. This approach leads to a speaker-hearer model similar to the model given in Figure 1, and hence gives rise to a closer contact between psychologists and linguists.

II-iii. Some Critical Issues in Linguistic Theory

Chomsky and Miller (Luce, Bush, and Galanter, 1963, p. 283) define a language to be a set of (finite or infinite) sentences each finite in length and constructed by concatenation out of a finite set of elements. The definition of the sentence becomes rather important, for language is defined in terms of it, and a grammar is motivated to generate sentences. Let us study the definition of a sentence to understand what a sentence is.

(3) **He is a man.**

is a sentence of English.

(4) **He is a man who wears an old coat.**

is another sentence, and (3) is a part of this.

(5) **He is a man who wears an old coat which has many colors on it.**

is another sentence which includes (3), and (4) in it.

Then what is a sentence? It is not only a grammatical utterance, it also has an **intention** which gives the uniqueness of the sentence. We would like

to emphasize this point for we can be led into the psycholinguistic theory from here.

A human being with an intention (I) to communicate has more than one alternative to select among the communicative codes. He might use linguistic code and communicate his (I), but he may, under some given conditions, choose a nonverbal code, i. e., facial expressions, postures, gestures, etc. The gestural language of the deaf people shows quite clearly that human beings are capable of communicating through non-linguistic code. This means that intentions of the source are not completely dependent on the code he uses. Thus intention might be relatively free of the code, but **the code structure is not independent of the intention.** In transformational grammar we see lack of concern with the characteristics of intentional unity of sentences. A sentence is a grammatical utterance which expresses the intention of the speaker. If one asks the speaker who uttered statement (5) whether statement (3) is a sentence, he would most probably say «No, it is a part of my sentence.» This indicates that a model of language cannot be independent of the model of the speaker-hearer. If we accept this conclusion then the relation between linguistics and psychology should be taken more seriously than it has been up to date by both the linguists and psychologists.

BIBLIOGRAPHY

- Attneave, F. (1959). **Applications of information theory to psychology.** New York, Henry Holt.
- Bloomfield, L. (1933). **Language.** Holt, Rinehart and Winston, New York.
- Cherry, C. (1961). **On human communication.** Science editions, John Wiley & Sons Inc., New York.
- Chomsky, N. (1957). **Syntactic structures.** Mouton & Co., The Hague.
- Fodor, J. A. and Katz, J. J. (1964). **The structure of language, readings in the philosophy of language.** Prentice Hall Inc., Englewood Cliffs,
- Herdan, G. (1956). **Language as choice and chance.** P. Noordhoffn, New York.
- Luce, D. R., Bush, R. R. and Galanter, E. (1963). **Handbook of mathematical psychology.** John Wiley & Sons, Inc. New York.
- Maclay, H. and Osgood, C. E. (1959). Hesitation phenomenon in spontaneous English speech. **Word**, 1959, 19-44.
- Osgood, C. E. (1957). Motivational dynamics of language behavior, in M. R. Jones (ed) **Nebraska symposium on motivation** Lincoln, Nebr. Univ. of Nebraska Press.
- Osgood, C. E. and Wilson, K. (1960). Some terms and associated measures for talking about human communication. Institute of Communications Research, (Mimeo).
- Osgood, C. E. (1966). On understanding and creating sentences. Institute of Communications Research publication (Mimeo).
- Quastler, H. (1955). **Information Theory in psychology: problems and methods,** The Free Press, Publishers, Glencoe, Ill.
- Pierce, J. R. (1961). **Symbols, signals, and noise.** Harper Torchbooks, Harper and Row Publishers, New York.
- Saporta, S. (1961). **Psycholinguistics, a book of readings.** Holt, Rinehart and Winston, New York.
- Shannon, C. E., and Weaver, W. (1949). **The mathematical theory of communication.** The University of Illinois Press, Urbana, Ill.