

ISSN 1308-5301 Print  
ISSN 1308-8084 Online

# *Biological Diversity and Conservation*

CİLT/VOLUME 9 SAYI 2 (Özel Sayı 1)/NUMBER 2 (Special Issue 1) AĞUSTOS/AUGUST 2016

***Special Issue Volume 9/2 (S1) August 2016***

Biyolojik Çeşitlilik ve Koruma Üzerine Yayın Yapan Hakemli Uluslararası Bir Dergidir  
*An International Journal is About Biological Diversity and Conservation With Refree*



Biyolojik Çeşitlilik ve Koruma  
*Biological Diversity and Conservation*

Biyolojik Çeşitlilik ve Koruma Üzerine Yayın Yapan Hakemli Uluslararası Bir Dergidir  
*An International Journal is About Biological Diversity and Conservation With Refree*  
Cilt/Volume 9 Sayı 2 (Özel Sayı 1)/Number 2 (Special Issue 1) Ağustos/August 2016

**Special Issue Volume 9/2 (SI) August 2016**

Editör / *Editor-in-Chief*: Ersin YÜCEL  
Misafir Editör / *Guest Editor* : Sezgin AYAN

ISSN 1308-5301 Print; ISSN 1308-8084 Online

**Açıklama**

“Biological Diversity and Conservation”, biyolojik çeşitlilik, koruma, biyoteknoloji, çevre düzenleme, tehlike altındaki türler, tehlike altındaki habitatlar, sistematik, vejetasyon, ekoloji, biyocoğrafya, genetik, bitkiler, hayvanlar ve mikroorganizmalar arasındaki ilişkileri konu alan orijinal makaleleri yayınlar. Tanımlayıcı yada deneysel ve sonuçları net olarak belirlenmiş deneysel çalışmalar kabul edilir. Makale yazım dili Türkçe veya İngilizce’dir. Yayınlanmak üzere gönderilen yazı orijinal, daha önce hiçbir yerde yayınlanmamış olmalı veya işlem görüyor olmamalıdır. Yayınlanma yeri Türkiye’dir. Bu dergi yılda üç sayı yayınlanır.

**Description**

“Biological Diversity and Conservation” publishes original articles on biological diversity, conservation, biotechnology, environmental management, threatened of species, threatened of habitats, systematics, vegetation science, the ecology, biogeography, genetics and interactions among plants and animals or microorganisms. Descriptive or experimental studies presenting clear research questions are accepted. The submitted paper must be original and unpublished or under consideration for publication. Manuscripts in English or in Turkish languages are welcome. Printed in Turkey. This journal is published triannullay.

**Dergiyi tarayan veri tabanları / Abstracted-Indexed in**

AGRICOLA; Bibliotheken; Buscador de Archives; Dayang Journal System; DOAJ-Directory of Open Access Journals; EBSCO Publishings databases; ECSI; Genamics JournalSeek Database; HealthHaven; HKU Scholars Hub.; ICAAP-database; Index Copernicus; InfoBaseIndex; I2OR; IJIF database, Journal Directory, News-of-Science; MNIS; OhioLINK Databases-OPC4-Online-Katalog der Bibliothek der Fachhochschule Anhalt; Online-Katalog der UB Clausthal; Paper Search Engine; ProQest-Central To Rechearch Araund The World; Thomson Reuters; Turkey Citation Index, Ulakbim; Zoological Record.

**Kütüphaneler / Libraries**

Aberystwyth University; All libraries; Bath University; Birmingham University; Cardiff University ;City University London; CONSER (Not UK Holdings); Edinburgh University; Essex University; Exeter University; EZB Electronic Journals Library; Feng Chia University Library; GAZI Gazi University Library; Glasgow University; HEC-National Digital Library; Hull University; Imperial College London; Kaohsinug Medical University Library; KYBELE Anadolu University Library; Lancaster University; Libros PDF; Liverpool University; London Metropolitan University; London School of Economics and Political Science; Manchester University; National Cheng Kung University Library; National ILAN University Library; Nottingham University; Open University; Oxford University; Queen Mary,University of London;Robert Gordon University; Royal Botanic Gardens, Kew; Sheffield Hallam University; Sheffield University; Shih Hsin University Library; Smithsonian Institution Libraries; Southampton University; Stirling University; Strathclyde University; Sussex University; The National Agricultural Library (NAL); The Ohio Library and Information NetWork; Trinity College Dublin; University of Washington Libraries; Vaughan Memorial Library; York University.

**IndexCopernicus, ICV: 9.00; Thomson Reuters Impact Factor, 5.00**

**“Türkiye Atıf Dizini”ne kayıtlıdır. (This journal is registered to “Turkey Citation Index”)**

Makale yazım kuralları ve dergi ile ilgili diğer ayrıntılar için ” [http:// www.biodicon.com](http://www.biodicon.com)“ adresini ziyaret ediniz / Please visit ” [http:// www.biodicon.com](http://www.biodicon.com)“ for instructions about articles and all of the details about journal

**Yazışma Adresi / Correspondance Adres:** Prof. Ersin YÜCEL, P.K. 86, PTT Merkez, 26010 Eskişehir / Turkey

**E-posta / E-mail** : [biodicon@gmail.com](mailto:biodicon@gmail.com) ;

**Web Address:** <http://www.biodicon.com>

#### Editörler / Editorial Board

Amed A. Azmani, Tangier (Morocco)  
Ahmet Aksoy, Antalya (Turkey)  
Ali Dönmez, Ankara (Turkey)  
Atilla Ocak, Eskişehir (Turkey)  
Alper Yargıç, Eskişehir (Turkey)  
Cemil Ata, İstanbul (Turkey)  
Ignacy Kitowski, Lublin (Poland)  
İlgaz Akata, Ankara (Turkey)  
İqrar Ahmad Khan, Faisalabad (Pakistan)  
Ian C. Hedge, Edinburgh, (Scotland, Uk)  
Lyutsiya Aubakirova, Astana (Kazakhstan)  
İlkin Yücel Şengün, İzmir (Turkey)  
M. Hakkı Alma, Maraş (Turkey)  
Masoud Hedayatifard, Ghaemshahr (Iran)  
M.N.V. Prasad, Hyderabad (India)  
Mırza Barjees Baig, Riyadh (Saudi Arabia)  
Muhammad Ashraf, Faisalabad (Pakistan)  
Münir Öztürk, İzmir (Turkey)  
Naime Polatdemir Arslan, Eskişehir (Turkey)  
Tülay Ezer, Niğde (Turkey)  
Yunus Doğan, İzmir (Turkey)

#### Alan editörleri/Subject specialist editors

Ayşe Ak, Erzincan (Turkey)  
M. Hakan Akyıldız, Kastamonu (Turkey)  
Sezgin Ayan, Kastamonu (Turkey)  
Ahmet Faik Ayaz, Trabzon (Turkey)  
Derya Eşen, Düzce (Turkey)  
Deniz Güney, Trabzon (Turkey)  
Alkan Günlü, Çankırı (Turkey)  
Dr. Deren Tahmas Kahyaoğlu, Kastamonu (Turkey)  
Alperen Kaymakci, Kastamonu (Turkey)  
Nuri Öner, Çankırı (Turkey)  
Halil Barış Özel, Bartın (Turkey)  
Sevgi Öztürk, Kastamonu (Turkey)  
Çiğdem Sakici, Kastamonu (Turkey)  
Oytun Emre Sakici, Kastamonu (Turkey)  
Fahrettin Tilki, Artvin (Turkey)  
Önder Tör, Kastamonu (Turkey)

#### Hakemler/ Reviewer

Abdeslam Annabili, Mezraoua (Morocco)  
Abdullah Kaya, Karaman (Turkey)  
Ahmed Bakrim, Kbouribga (Morocco)  
Ahmet Emre Yaprak, Ankara (Turkey)  
Amed Aarab Azmani, Tangier (Morocco)  
Anath Bandhu Das, Ankara (Turkey)  
Angeles Alonso Vargas, Alicante (Spain)  
Aslı Doğru Koca, Ankara (Turkey)  
Aykut Güvensen, İzmir (Turkey)  
Aziz Türkoğlu, Muğla (Turkey)  
Bahar Bayhan, İzmir (Turkey)

Barış Bani, Kastamonu (Turkey)  
Burhan Şen, Tırakya (Turkey)  
Cahit Doğan, Ankara (Turkey)  
Celal Yarıç, İstanbul (Turkey)  
Cem Vural, Kayseri (Turkey)  
Cihan Darcan, Bilecik (Turkey)  
Dalila Bousta, Taounate (Morocco)  
Duygu Kızıla, İzmir (Turkey)  
Ece Sevgi, İstanbul (Turkey)  
Elif Yamaç, Eskişehir (Turkey)  
Emel Sözen, Eskişehir (Turkey)  
Ergin Hamzaoğlu, Ankara (Turkey)  
Ernaz Altundağ, Düzce (Turkey)  
Erkan Yalçın, Samsun (Turkey)  
Ersen Aydın Yağmur, Manisa (Turkey)  
Esat Çetin, Sakarya (Turkey)  
Evren Cabi, Tekirdağ (Turkey)  
Eylem Akman Gündüz, Samsun (Turkey)  
Fatih Satıl, Balıkesir (Turkey)  
Faruk Selçuk, Kırşehir (Turkey)  
Fatma Güneş Koçyiğit, Trakya (Turkey)  
Fazle Subhan, Peshawar, (Pakistan)  
Ferhat Celep, Nevşehir (Turkey)  
Filiz Savaroğlu, Eskişehir (Turkey)  
Gencay Akgül, Nevşehir, (Turkey)  
Gökhan Abay, Çankırı (Turkey)  
Gülriş Bayçu, İstanbul (Turkey)  
Haider Abbas, Karachi (Pakistan)  
Halil Koç, Sinop (Turkey)  
Hasan Akgül, Gaziantep (Turkey)  
Hatice Çölgeçen, Zonguldak (Turkey)  
Hatice Kiremit Özenoğlu, Aydın (Turkey)  
Hatice Tunca, Sakarya (Turkey)  
Hayat Badshah, Peshawar (Pakistan)  
Hüseyin Mısırdalı, Tunceli (Turkey)  
İhsan A. Al-Shehbaz, Missouri (Usa)  
İltif Ullah , Nowshera (Pakistan)  
İbrahim Türkekul, Tokat (Turkey)  
İsa Telci, Tokat (Turkey)  
İskender Güllü, Burdur (Turkey)  
İsmet Uysal, Çanakkale (Turkey)  
İsmühan Potoğlu, Eskişehir (Turkey)  
Kadriye Uruç Parlak, Ağrı (Turkey)  
Kuddisi Ertuğrul, Konya (Turkey)  
Kürşat Özkan, Isparta (Turkey)  
Malik Faisal, İslamabad (Pakistan)  
Manzoor Ahmad, İslamabad (Pakistan)  
Marjan Komnenov, Skopje (Macedonia)  
Maryam Keshavarzi, Tehran (Iran)  
Matem Tunçdemir, İstanbul (Turkey)  
Mehmet Candan, Eskişehir (Turkey)  
Menderes Çenet, Osmaniye (Turkey)  
Meral Avcı, İstanbul (Turkey)  
Mırza Barjees Baig, Riyadh(Saudi Arabia)  
Mohammed Merzouki, Fez (Morocco)  
Muhammad Iqbal, Nwfp (Pakistan)  
Muhammad Sarwar, Jam (Pakistan)  
Muhammad Yasin Ashraf, (Pakistan)  
Muhammet Ören, Zonguldak (Turkey)  
Murad Aydın Şanda, Konya (Turkey)

Murat Olgun, Eskişehir (Turkey)  
Murat Dinçer Çekin, İstanbul (Turkey)  
Mustafa Cemal Darılmaz, Konya (Turkey)  
Mustafa Işıloğlu, Muğla (Turkey)  
Mustafa Korkmaz, Erzincan (Turkey)  
Mustafa Yamaç, Eskişehir (Turkey)  
Müge Sayitoğlu, İstanbul (Turkey)  
Nevzat Batan, Maçka/Trabzon (Turkey)  
Nur Münevver Pınar, Ankara (Turkey)  
Nurhayat Dalkıran, Bursa (Turkey)  
Nurcan Yiğit, Kastamonu (Turkey)  
Oğuzhan Şaygusuz, Denizli (Turkey)  
Onur Koyuncu, Eskişehir (Turkey)  
Orhan Erman, Elazığ (Turkey)  
Osman Karabacak, Polatlı (Turkey)  
Özdemir Şentürk, Burdur (Turkey)  
Perihan Kendirci, İzmir (Turkey)  
R. Süleyman Gökçürk, Antalya (Turkey)  
Rasime Demirel, Eskişehir (Turkey)  
Robert Angus, London (England)  
Perihan Güler, Kırıkkale (Turkey)  
Rıdvan Polat, Giresun (Turkey)  
Rıza Binzet, Mersin (Turkey)  
Rüştü Hatipoğlu, Adana (Turkey)  
Saleem Ahmad, İslamabad (Pakistan)  
Saye Nihan Çabuk, Eskişehir (Turkey)  
Seher Karaman Erkul, Aksaray (Turkey)  
Selima Khatun, West Bengal (India)  
Semra Soydam Aydın, Ankara (Turkey)  
Serdar Aslan, Düzce (Turkey)  
Serdar Makbul, Rize (Turkey)  
Seyhan Oran, Bursa (Turkey)  
Seyit Ahmet Sargın, Alanya (Turkey)  
Sezgin Çelik, İstanbul (Turkey)  
Shyam Singh Yadav, Lae (New Guinea)  
Sıdıka Ekren, İzmir (Turkey)  
Snejana Doncheva, Sofia (Bulgaria )  
Sumaira Sahren, İslamabad (Pakistan)  
Sunil Kumarkhan, Magra, Hooghly (India)  
Şengül Aksan, Akseki-Antalya (Turkey)  
Şeniz Karabıyıklı, Tokat (Turkey)  
Tahir Atıcı, Ankara (Turkey)  
Tamer Keçeli, Çankırı (Turkey)  
Tariq Danışman, Kırıkkale (Turkey)  
Tuğba Bayrak Özbucak, Ordu (Turkey)  
Tuna Uysal, Konya (Turkey)  
Tuncay Dirmenci, Balıkesir (Turkey)  
Turan Özdemir, Trabzon (Turkey)  
Uğur Çakılcıoğlu, Elazığ (Turkey)  
Ünal Özelmaz, Eskişehir (Turkey)  
Yavuz Bağcı, Konya (Turkey)  
Yeşim Kara, Denizli (Turkey)  
Yunus Serin, Kayseri (Turkey)  
Yusuf Menemen, Kırıkkale (Turkey)  
Yusuf Uzun, Van (Turkey)  
Zafer Cemal Özkan, Trabzon (Turkey)  
Zeki Aytac, Ankara (Turkey)



**Variations within and among populations depending on some leaf characteristics of oriental beech  
(*Fagus orientalis* Lipsky)**

Deniz GÜNEY<sup>\*1</sup>, Hülya TURNA<sup>2</sup>, İbrahim TURNA<sup>1</sup>, Şemsettin KULAÇ<sup>3</sup>, Fahrettin ATAR<sup>1</sup>, Ertuğrul FILİZ<sup>4</sup>

<sup>1</sup> Department of Forestry, Karadeniz Technical University, 61080, Trabzon, Turkey

<sup>2</sup> Eastern Mediterranean Forestry Research Institute, General Directorate of Forestry, 61080, Trabzon, Turkey

<sup>3</sup> Department of Forestry, Düzce University, 81620, Düzce, Turkey

<sup>4</sup> Çilimli Meslek Yüksekokulu, Düzce University, 81620, Düzce, Turkey

**Abstract**

At the beginning of the tree breeding programs, it is started over investigations of genetic variations. Thanks to the genetic variation investigations it is proved how does the scape of variations among populations and trees in populations change according to the variations like altitude, distance from sea and rain.

Oriental beech is a very important tree species in the forestry. It is aimed in this study to determine variations on the seedling which are grown from seeds picked from 11 different Oriental beech populations (Sinop-Merkez, Sinop-Ayancık, Samsun-Kunduz, Samsun-Karapınar, Karabük-Yenice, Düzce-Çiçekli, Trabzon-Maçka, Trabzon-Çaykara, Giresun-Kulakkaya, Ordu-Akkuş and Kahramanmaraş-Andırın) in terms of leaf width, leaf length, leaf area, leaf vein angle and leaf moisture. By making these measurements on the seedlings belong to the all populations, variations among populations connected to these characteristics are determined. Besides, measurements on tree basis was done by using 6000 leaves in 6 populations, ten trees from per populations, 10 seedlings from per tree, 10 leaves from per seedlings and differences within populations were determined by looking these characteristics.

As a result of the variance analysis which is done connected with leaf width, length, area and leaf vein angle it was determined that there are statistical differences among populations for all these characteristics. As a consequence of the variance analysis belong to the leaf measure, significance level is over 0.05. According to this result it is determined that 11 populations became homogenous depending leaf moisture. All the characters except for leaf moisture showed differences within 6 separate populations. Although populations are homogenous in terms of leaf moisture it is understood that trees within populations showed variations for these characters. According to the hierarchical cluster analysis Sinop-Merkez, Sinop-Ayancık and Karabük-Yenice populations are at the same group in terms of all leaf characters and other populations created other group.

**Key words:** Oriental beech, leaf length, leaf area, leaf moisture, variation, origin

----- \* -----

**Doğu kayınında (*Fagus orientalis* Lipsky) bazı yaprak karakterlerine ait populasyonlar arası ve içi varyasyonlar**

**Özet**

İslah (tree breeding) programlarının başlangıcında tür içi genetik çeşitlilik (varyasyon) araştırmaları üzerinde durulmaktadır. Genetik çeşitlilik araştırmaları sayesinde, çeşitliliğin populasyonlar arası ve populasyon içi ağaçlar arası kapsamı, bunun rakım, denizden uzaklık, yağış gibi değişkenlere göre nasıl değişim gösterdiği ortaya konulmaktadır.

Doğu Kayını ülkemiz ormancılığında önemli bir ağaç türüdür. Bu çalışmada, 11 farklı doğu kayını popülasyonundan (Sinop-Merkez, Sinop-Ayancık, Samsun-Kunduz, Samsun-Karapınar, Karabük-Yenice, Düzce-Çiçekli, Trabzon-Maçka, Trabzon-Çaykara, Giresun-Kulakkaya, Ordu-Akkuş ve Kahramanmaraş-Andırın) toplanan tohumlardan yetiştirilen 2+0 yaşındaki fidanlarda yaprak eni, yaprak boyu, yaprak alanı, yaprak damar açısı ve yaprak nemi bakımından meydana gelen varyasyonları belirlemek amaçlanmıştır. Bu ölçümler tüm populasyonlara ait

\* Corresponding author / Haberleşmeden sorumlu yazar: Tel.: +904623772877; Fax.: +904623257499; E-mail: d\_guney61@hotmail.com

fidanlarda yapılarak, bu özelliklere bağlı, populasyonlar arası varyasyonlar ortaya konulmuştur. Ayrıca, 6 populasyonda, her populasyondan 10 ağaç, her ağaçtan 10 fidan ve her fidandan 10 yaprakta olmak üzere toplam 6000 yaprak kullanılarak ağaç bazında ölçümler yapılmış ve bu özelliklere bağlı olarak populasyon içi farklılıklar belirlenmiştir.

Yaprak eni, yaprak boyu, yaprak alanı ve yaprak damar açısına ilişkin olarak gerçekleştirilen varyans analizi sonucunda bu karakterlerin hepsi için populasyonlar arasında istatistiksel olarak farklılıklar olduğu belirlenmiştir. Yaprak nemine ait varyans analizi sonucunda ise önem düzeyi 0.05'ten büyük çıkmıştır. Bu sonuca göre çalışılan 11 populasyonun, yaprak nemine bağlı olarak homojen bir yapı gösterdikleri belirlenmiştir. 6 populasyonun her birinin kendi içerisinde ise yaprak nemi dışındaki tüm karakterlerin farklılık gösterdiği belirlenmiştir. Yaprak nemi bakımından populasyonlar homojen bir yapı gösterse de, populasyonlar içerisindeki ağaçlar ise bu karakter bakımından varyasyonlar gösterdiği anlaşılmıştır.

Hiyerarşik kümeleme analizi sonucu oluşan gruplandırmaya göre; ölçülen tüm yaprak karakterleri bakımından Sinop-Merkez, Sinop-Ayancık ve Karabük-Yenice populasyonları aynı grup içerisinde yer almış olup diğer populasyonlar ise diğer grubu meydana getirmiştir.

**Anahtar kelimeler:** Doğu Kayını, yaprak eni, yaprak boyu, yaprak alanı, varyasyon, orijin

## 1. Introduction

In forests of our country have 54 % conifer forests and 46 % deciduous forests. Beech represented by 10 species in the Northern Hemisphere is one of the most important types of deciduous forests. There are two types including Oriental beech (*Fagus orientalis* Lipsky.) and European beech (*Fagus sylvatica* L.) in Turkey. Oriental beech has a wider spread than the other type. Oriental beech in our country is spreading in 1.961.660 ha area, including 1.621.257 ha forest in normal structure and 340.403 ha forest in discontinuous structure (Anonymous, 2014; Ertekin et.al., 2015).

As is known, afforestation efforts are expensive and long-term investments. It is required to use seeds and seedling which have superior genetic qualities in order to guarantee the future of these investments. To determine the genetic quality of the seedlings, it is essential to know the genetic variation of the trees in the population (Yahyaoglu and Genç, 2007). Today, it can be made in a more sensitive manner origin certification by genetic variation researches. Thus, it can be possible to do afforestation efforts through actual origins and without causing genetic contamination. Results obtained from this study are intended to contribute to the realization of these matters.

Each population, in order to adapt to different environmental conditions which are effective in its region, is considered genetically unique (Işık and Yıldırım, 1990). Therefore, use of other biological information together with population genetic principles in management of these populations is even more important (Namkoong, 1989).

It is expressed that the best way to determine the genetic variation for a species will be by comparison of populations in different habitats (Chmura, 2002). Species which are spread very wide areas have very much geographical variation and local races in the same time (Işık, 1981; Zobel and Talbert 1984; Kaya, 1990). Broken geographical structure, changing climate and soil characteristics over short distances of Turkey have encouraged the formation of local races even short distances in forest tree populations (Işık, 1988; Kaya 1989). Due to the showing spread in such a geographic region of oriental beech, it may have genetically variations.

In this study, it is aimed to investigate of variations in populations in natural distribution areas in our country for oriental beech (*Fagus orientalis* Lipsky.), one of main tree species in our country, depending on some morphological characters belong to leaf.

## 2. Materials and methods

In this study, as the study material has been selected 11 natural oriental beech populations that represented the natural range of oriental beech in Turkey. Leaves belong to seedlings that grown by seeds collected from a total of 225 trees including average of 20 pieces from each of these populations have been used.

### 2.1. Determination of sample populations

In accordance with to the research objectives, 11 oriental beech populations, which are able to represent Turkey, have been selected. Accordingly, it has been made measurements on leaves of seedlings that grown by seeds collected from Sinop-Merkez, Sinop-Ayancık, Samsun-Kunduz, Samsun-Karapınar, Karabük-Yenice, Düzce-Çiçekli, Trabzon-Maçka, Trabzon-Çaykara, Giresun-Kulakkaya, Ordu-Akkuş and Kahramanmaraş-Andırın populations. Some informations related to sites of populations collected seed material have been given in Table 1, and the geographical location of the populations have been given in Figure 1.

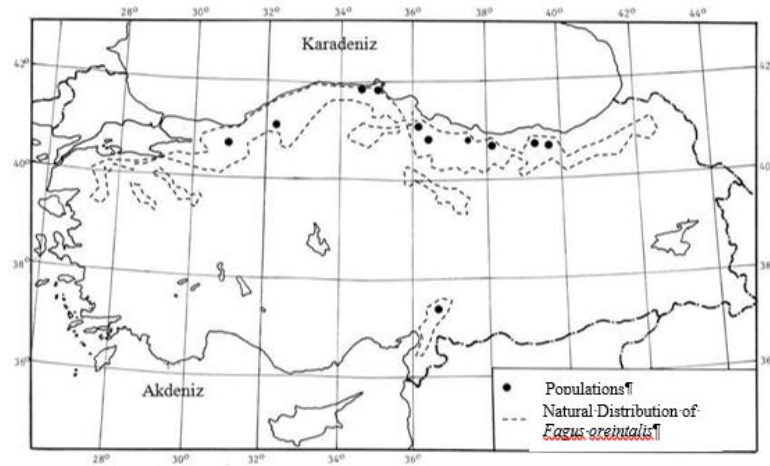

Figure 1. The geographical location of the populations collected seed material

Table 1. Information on the sample plots

Pop No	Name of Population	Tree Number (N)	*East Longitude	*North Latitude	Altitude	Aspect Groups
1	Sinop Merkez	21	646426-645002	4530786-4531627	90-140	N, NW, E, S, SW
2	Sinop Ayancık	26	644126-647212	4633190-4635389	605-745	N, NE, NW, E, S, SW
3	Samsun Kunduz	20	666533-665881	4559311-4559075	1300-1390	N, NE, NW
4	Samsun Karapınar	20	685470-685433	4549004-4549406	1250-1360	N, NE
5	Karabük Yenice	20	452653-457710	4566618-4576555	610-1100	N, NE, NW, E, S, SW
6	Trabzon Maçka	19	536104-537264	4502315-4502863	1510-1650	N, NE, NW, E, SW, W
7	Trabzon Çaykara	18	602433-603016	4504412-4506099	920-1485	NE, E, S, SW, SE, W
8	Giresun Kulakkaya	18	442625-452537	4503642-4504163	455-1460	N, NE, W, S
9	Ordu Akkuş	23	331483-331845	4519805-4520234	1200-1315	N, NE, NW, ES, SE, SW
10	Düzce Çiçekli	20	853080-855918	4507317-4508900	1310-1405	N, NE, NW
11	K. Maraş Andırın	20	269188-272115	4175208-4185518	1395-1740	N, NE, NW, E, SE, W

\* The coordinates of the sample plots have been taken by the UTM coordinates system.

## 2.2. Measurements related to leaf

Leaf width, leaf length, leaf area, leaf vein angle and leaf moisture values have been measured in 2+0 years-old oriental beech seedlings. Variations among populations have been revealed with measurements made in seedlings belong to all populations in terms of these features. Also, measurements on the basis of tree have been performed using a total of 6,000 leaves, included 10 trees from each population, 10 seedlings from each tree and 10 leaves from each seedlings, in Düzce-Çiçekli, Trabzon-Maçka, Trabzon-Çaykara, Giresun-Kulakkaya, Ordu-Akkuş and Kahramanmaraş-Andırın populations. And, differences within population have been determined depending on these features.

Leaf vein angle has been obtained by measuring 3 different parts included bottom, middle and upper parts of leaf in each leaf.

Measurements related leaves were performed using the ImageJ (Image Analysis Software) program. This program were used in various scientific studies carried out to examine the variation in leaf (Bayramzadeh et al., 2008)

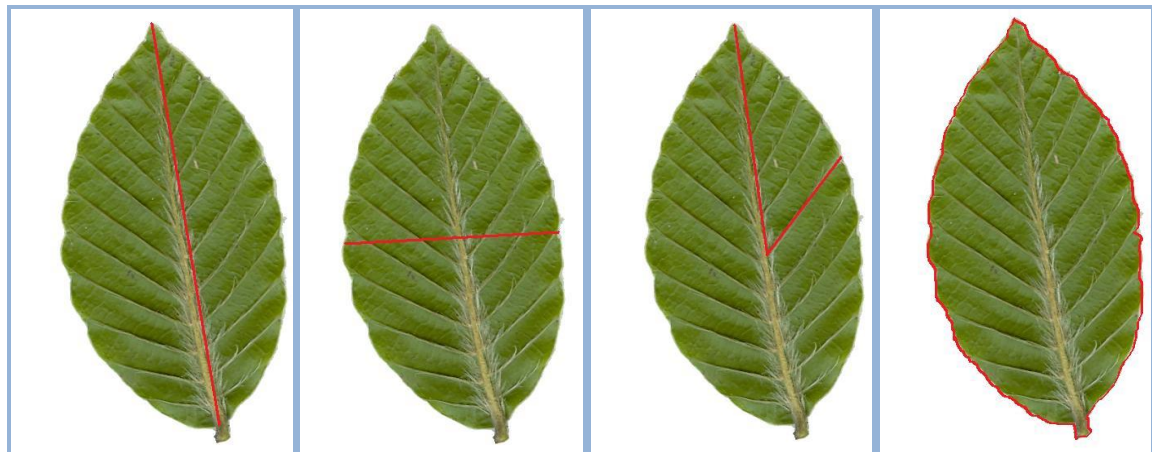
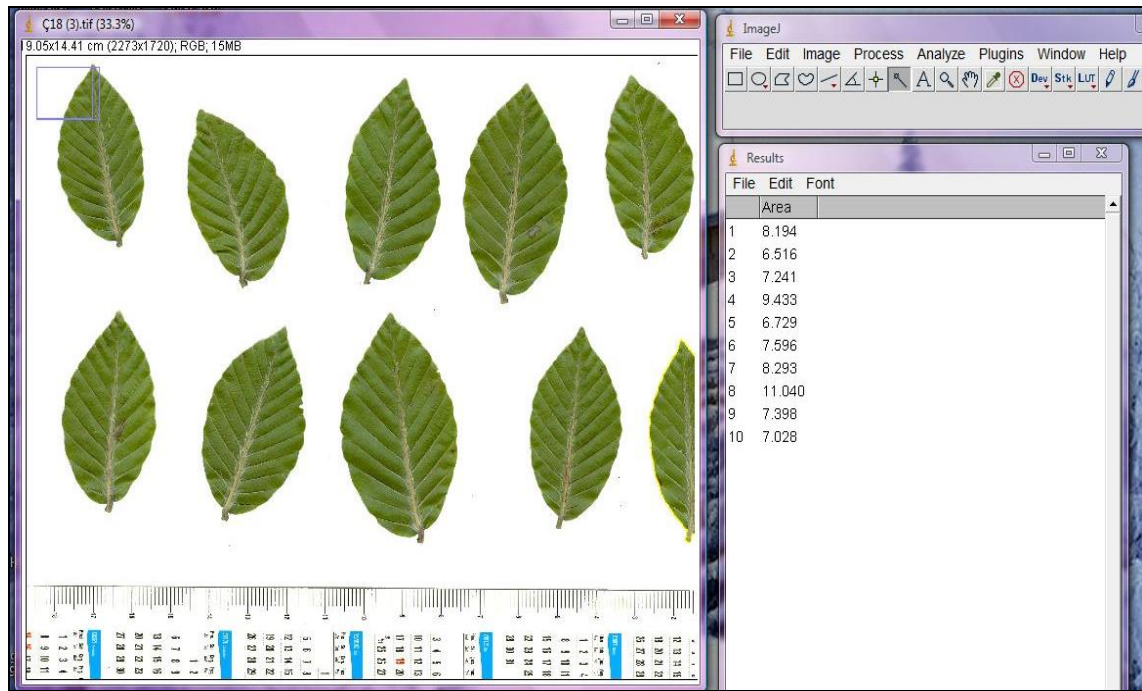

Figure 2. Measurement of leaf length, leaf width, leaf vein angle and leaf area using ImageJ (Image Analysis Software) software.

### 2.3. Data analysis

Data were analyzed using the SPSS 20.0 statistical program. The analyses conducted included ANOVA, Duncan's Test and Cluster.

## 3. Results

Leaf width, leaf length, leaf area, leaf vein angle and leaf moisture have been measured by using leaf samples obtained from seedlings belong to populations under study.

The average leaf width, leaf length, leaf area, leaf vein angle and leaf moisture values for all populations have been given with standard deviations in Table 2.

Analysis of variance has been performed to determine whether the differences in terms of measured these characters belong to leaf among populations. Duncan test has been conducted to determine groups. And then, the results have been given in Table 2. As can be seen from the table, as a result of analysis of variance carried out related to leaf width, leaf length, leaf area and leaf vein angle has been determined that there are differences as statistically for all these characters. Significance level is greater than 0.05 as a result of analysis of variance performed related to leaf moisture. According to this result, it can be said that 11 populations under study show a homogeneous structure in terms of leaf moisture.

Table 2. The results of the analysis of variance and Duncan test concerning leaf width, leaf length, leaf area, leaf vein angle and leaf moisture values among populations

Pop.	Avg. Leaf Width (cm)	Avg. Leaf Length (cm)	Avg. Leaf Area (cm <sup>2</sup> )	Avg. L. Vein Angle (Degree)	Avg. L. Moisture (%)
Sinop	3.45±0.51 f	5.70±0.72e	13.61±3.47 e	44.92±9.36 a	67.20±7.45
S.Ayancık	3.23±0.52 d	5.36±0.88de	12.20±3.89 e	47.60±8.58 bc	67.60±6.96
Kunduz	2.51±0.54 ab	4.32±0.88 a	7.69± 3.30 ab	47.60±10.06bc	68.60±5.74
Karapınar	2.59±0.33 ab	4.67±0.56 b	8.50±1.90 bc	43.96±9.57 a	68.50±7.44
Yenice	2.93±1.10 c	5.35±2.01de	12.22±9.65 e	46.48±9.22 b	68.60±6.55
Maçka	2.88±0.65 c	5.15±1.02cd	10.63±4.55 d	48.24±4.05 d	64.80±5.77
Çaykara	2.72±0.61 bc	4.84±0.98 bc	9.78±4.02 cd	47.18±5.40 bc	64.04±6.69
Kulakkaya	2.72±0.64 bc	4.84±1.06 bc	9.34±4.43 cd	47.88±5.80 d	65.90±4.50
Akkuş	2.84±0.62 c	4.99±1.03bcd	10.10±4.33 d	47.10±5.80 bc	63.76±10.4
Çiçekli	2.34±0.60 a	4.07±0.89 a	7.05±3.04 a	46.11±4.41 a	66.95±8.08
Andırın	2.41±0.61 a	3.99±1.05 a	7.38±3.66 ab	45.15±5.84 a	66.04±5.77
Avg.	2.66±0.66	4.66±1.10	9.08±4.31	46.55±5.82	66.30±1.85
Anova	F:70.250 P: 0.000**	F:122.814 P: 0.000**	F:78.669 P: 0.000**	F:44.144 P: 0.000**	F:1.697 P: 0.133

\*\* There is difference as statistically. Significance level  $P < 0.01$

As a result of Duncan test conducted to determine different groups have formed in terms of leaf length. When we examine to composed groups, Sinop-Merkez population has had the highest values in terms of leaf width, leaf length and leaf area. Additionally, Düzce-Çiçekli population and K.Maraş-Andırın population have had the lowest values in terms of these characters. Sinop-Merkez population, having the highest value, has formed alone a group in terms of leaf width and leaf length. Sinop-Merkez population has taken place in the same group with Sinop-Ayancık and Karabük-Yenice populations in terms of leaf area. Düzce-Çiçekli population, having the lowest value, has formed alone a group in terms of leaf area. Düzce-Çiçekli population has taken place in the same group with K.Maraş-Andırın population in terms of leaf width and, has taken place in the same group with K.Maraş-Andırın and Samsun-Kunduz populations in terms of leaf length. When we look at Duncan test results, populations forming other groups show a similar ranking according to measured characters. Unlike the previous groupings, Sinop-Merkez population has taken place in the same group with Düzce-Çiçekli, K.Maraş-Andırın and Samsun-Karapınar populations in terms of leaf vein angle. Trabzon-Maçka population, which has the largest vein angle, has formed alone a group in terms of leaf vein angle.

Graphical distribution of populations, in terms of leaf width, leaf length, leaf area, leaf vein angle and leaf moisture values, has been given in Figure 3 and Figure 4.

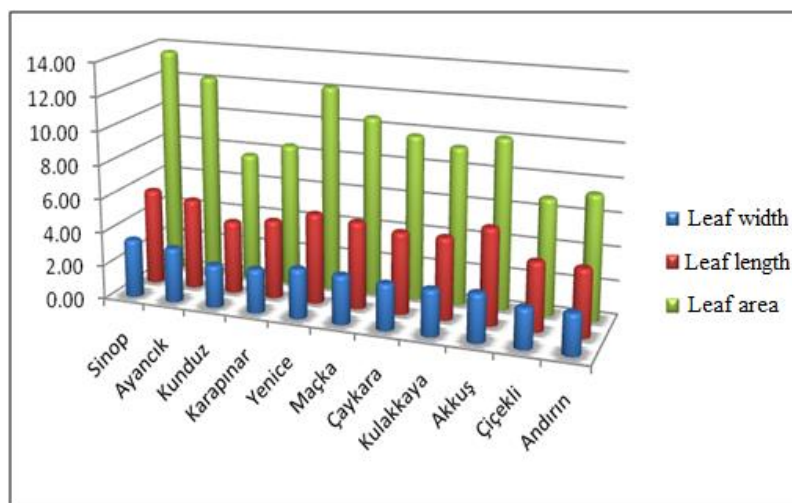

Figure 3. According to populations, leaf width (cm), leaf length (cm) and leaf area (cm<sup>2</sup>)



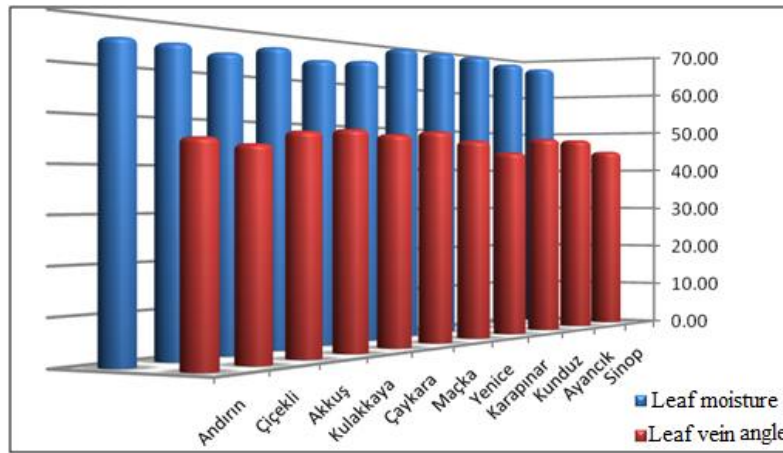

Figure 4. According to populations, leaf moisture (g) and leaf vein angle (degree)

As can be seen from Figure 3, leaf width, leaf length and leaf area show a parallel change according to populations. Leaf vein angle is not in the same direction with these features. According to conducted correlation analysis, leaf vein angle has not showed a significant correlation with other leaf characteristics. This situation supports the results obtained. It has been determined that leaf moisture has taken very close values one another, and has not exhibited a statistically change according to population.

It has been tested by analysis of variance to determine whether difference with regard to measured leaf characteristics within populations. Whether 6 populations, in terms of the average leaf width, leaf length, leaf area, leaf vein angle and leaf moisture, show a variation, and average values for these populations have been given with standard deviations in Table 3. The results of analysis of variance and averages leaf width, leaf length, leaf area, leaf vein angle and leaf moisture values belong to seedlings that grown by seeds obtained from populations have been given in Table 3. As can be seen from table, the result of analysis of variance conducted in terms of leaf moisture, it has been determined that Trabzon-Maçka and Ordu-Akkuş populations have exhibited differ within themselves with % 95 confidence level, and Giresun-Kulakkaya and Kahramanmaraş-Andırın populations have exhibited differ within themselves with % 99 confidence level. It has been determined that Trabzon-Çaykara and Düzce-Çiçekli populations have not displayed variation within population in terms of this character. Each population has had smaller than significance level of 0.01 in terms of leaf width, leaf length, leaf area and leaf vein angle characters. According to this result, it has been determined that each population has exhibited differ within themselves related to these characters.

A statistical analysis has been made with hierarchical cluster analysis as using leaf width, leaf length, leaf area, leaf vein angle and leaf moisture values in order to determine how populations involved in graphically a grouping. And then, the significance of this groupings has been tested by discriminant analysis.

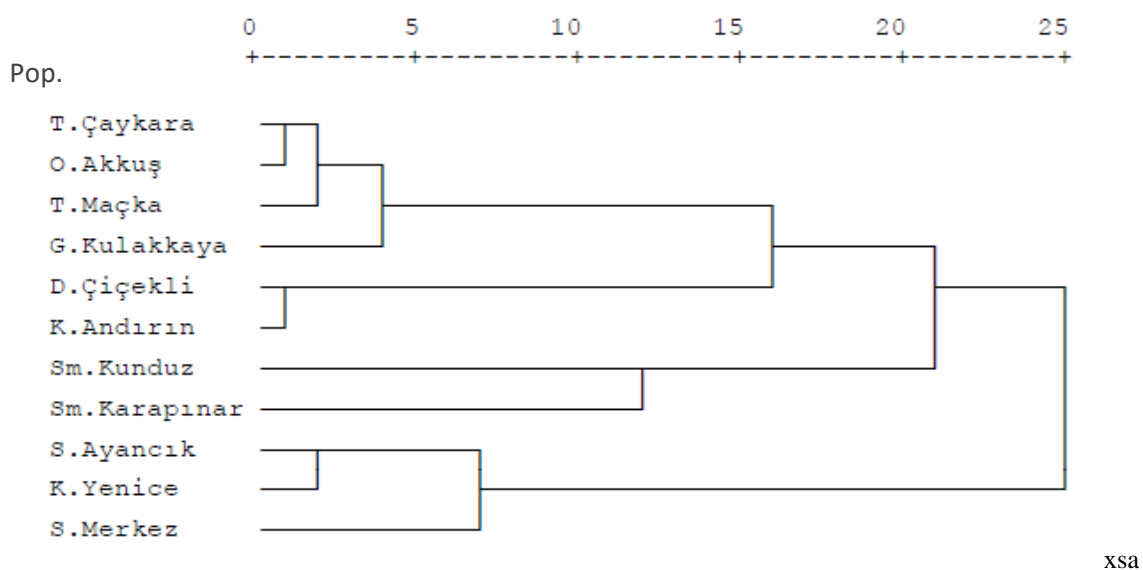

Figure 5. Dendrogram obtained with Cluster analysis related to leaf width, leaf length, leaf area, leaf vein angle and leaf moisture

Table 3. The results of the analysis of variance and averages concerning leaf width, leaf length, leaf area, leaf vein angle and leaf moisture values within populations

Tree No	Trabzon-Maçka					Trabzon-Çaykara					Giresun-Kulakkaya				
	LW (cm)	LL (cm)	LA(cm <sup>2</sup> )	LVA (°)	LM(%)	LW (cm)	LL (cm)	LA(cm <sup>2</sup> )	LVA (°)	LM(%)	LW (cm)	LL (cm)	LA(cm <sup>2</sup> )	LVA (°)	LM(%)
1	3.14±0.75	5.38±1.23	12.41±5.73	49.10±3.8	62.88±4.5	2.56±0.55	4.62±0.82	8.73±3.27	46.93±4.5	59.74±4.0	2.22±0.43	4.03±0.83	6.29±2.38	46.20±5.8	68.81±3.8
2	3.00±0.48	5.45±0.79	11.54±3.43	47.60±3.4	65.61±10.1	2.87±0.54	4.93±0.83	10.30±3.63	46.69±5.2	68.55±2.1	3.12±0.84	5.49±1.26	12.06±6.69	48.33±6.5	67.50±3.6
3	3.15±0.79	5.58±1.24	12.66±6.14	48.24±4.2	63.82±3.6	2.66±0.46	4.52±0.74	8.91±3.02	49.35±4.3	66.33±3.6	2.91±0.54	5.04±0.87	10.21±3.72	47.95±5.4	65.88±2.7
4	3.09±0.58	5.44±0.91	11.63±3.93	48.32±3.5	67.86±4.2	2.67±0.63	4.89±0.81	9.67±3.86	45.40±6.3	63.31±2.2	2.90±0.50	4.92±0.81	9.92±3.25	47.01±4.8	62.05±2.5
5	2.53±0.50	4.68±0.82	8.32±3.13	47.79±4.0	62.83±2.6	2.77±0.57	5.18±1.06	10.66±4.05	47.30±4.9	63.21±1.7	2.67±0.50	4.75±0.90	8.87±3.28	47.41±5.0	64.59±3.2
6	3.02±0.69	5.18±1.09	11.44±4.88	48.03±4.3	63.73±8.2	3.12±0.58	5.46±0.84	12.56±4.31	48.18±4.4	64.33±1.3	2.67±0.66	4.96±1.07	9.24±4.90	48.21±7.0	63.05±3.2
7	2.48±0.47	4.57±0.83	7.94±2.92	47.75±3.8	66.14±2.3	2.82±0.60	4.99±1.07	10.52±4.26	45.84±6.5	64.39±2.5	2.24±0.45	4.08±0.68	6.47±2.31	48.91±6.1	64.05±2.6
8	2.73±0.57	4.99±0.95	9.70±3.98	46.95±4.4	62.85±2.9	2.48±0.58	4.41±0.88	8.27±3.50	47.08±6.1	67.13±2.6	3.02±0.47	5.44±0.89	11.55±3.45	48.98±4.4	71.27±5.6
9	2.80±0.58	5.13±0.86	10.30±3.72	48.85±3.7	69.37±7.8	2.86±0.61	5.07±0.90	10.45±3.85	46.81±4.7	59.64±7.7	2.56±0.69	4.88±0.78	8.17±3.02	47.11±6.4	65.72±4.8
10	2.87±0.60	5.10±0.81	10.43±3.92	49.77±4.2	63.21±2.7	2.47±0.60	4.39±1.06	8.15±3.78	47.73±5.3	63.12±9.1	2.98±0.66	5.14±0.53	9.99±5.91	48.87±5.0	63.14±3.6
Avg.	2.88±0.65	5.15±1.02	10.63±4.55	48.24±4.1	64.80±5.7	2.72±0.61	4.84±0.98	9.78±4.02	47.18±5.4	64.04±6.6	2.72±0.44	4.84±1.06	9.34±4.43	47.88±5.8	65.90±4.5
F	15.709	11.713	13.852	4.148	1.698	11.279	12.965	11.212	4.038	1.815	35.988	34.638	10.575	2.741	7.672
S	<0.00	<0.00	<0.00	<0.00	<0.101	<0.00	<0.00	<0.00	<0.00	0.067	<0.001	<0.001	<0.001	<0.008	<0.008
Tree No	Ordu-Akkuş					Düzce-Çiçekli					Kahramanmaraş-Andırın				
	LW (cm)	LL (cm)	LA(cm <sup>2</sup> )	LVA (°)	LM(%)	LW (cm)	LL (cm)	LA(cm <sup>2</sup> )	LVA (°)	LM(%)	LW (cm)	LL (cm)	LA(cm <sup>2</sup> )	LVA (°)	LM(%)
1	2.93±0.60	5.10±1.00	10.82±4.84	49.43±4.7	68.42±2.2	4.56±1.00	2.53±0.59	8.15±3.47	44.97±4.2	69.30±3.4	1.86±0.43	3.26±0.78	4.57±1.94	43.81±5.6	67.53±1.8
2	2.40±0.58	4.16±0.83	7.30±3.12	48.18±5.4	63.45±4.3	4.06±0.71	2.20±0.45	6.16±2.24	43.24±3.6	63.67±1.9	2.27±0.68	3.40±0.99	6.11±3.36	46.11±5.2	62.59±5.1
3	3.19±0.68	5.52±1.10	12.65±5.19	51.81±5.5	64.68±1.6	3.39±0.87	2.00±0.55	5.08±2.67	44.83±3.7	57.64±16.8	2.35±0.47	3.74±0.85	6.73±2.80	45.77±6.5	65.13±2.6
4	2.83±0.61	4.83±0.89	9.73±4.11	45.00±5.5	62.25±2.5	4.10±0.61	2.37±0.43	6.87±2.21	41.98±4.3	62.30±2.2	2.16±0.54	3.86±0.88	6.26±2.94	43.69±4.1	67.30±2.4
5	2.68±0.57	4.68±0.99	9.00±3.46	45.65±5.3	58.81±8.8	3.86±0.78	2.31±0.54	6.53±2.99	43.88±4.7	65.24±2.4	2.41±0.63	4.31±1.54	8.15±4.78	41.55±5.7	68.35±3.7
6	3.27±0.50	6.07±1.12	14.06±4.57	44.38±5.4	67.18±1.6	3.91±0.87	2.10±0.46	5.93±2.52	45.48±4.0	65.94±1.7	2.52±0.58	4.03±0.83	7.67±3.61	47.88±5.6	63.70±2.5
7	2.71±0.49	4.74±0.76	9.02±3.09	48.97±4.9	73.35±13.5	4.28±1.18	2.78±0.92	8.32±4.15	43.20±3.6	65.01±6.5	2.25±0.44	3.65±0.69	6.25±2.27	43.13±4.4	61.66±6.9
8	2.76±0.58	4.91±0.88	9.36±3.93	46.33±5.2	61.65±2.0	3.85±0.90	2.42±0.67	6.87±3.25	45.21±5.5	65.74±4.1	2.93±0.59	4.58±0.77	10.06±3.49	44.46±5.8	66.12±3.4
9	2.62±0.48	4.73±0.84	8.57±3.04	46.00±5.7	60.44±2.4	4.45±0.53	2.52±0.35	7.84±1.96	43.63±4.1	64.32±3.3	2.61±0.57	4.64±1.02	9.01±3.95	46.53±5.8	69.50±3.0
10	3.00±0.49	5.31±0.70	11.01±3.14	47.70±5.9	62.49±2.6	3.86±0.67	2.28±0.44	6.36±2.29	43.67±3.9	64.79±2.4	2.53±0.53	4.29±0.84	8.03±3.03	47.81±4.9	68.56±1.7
Avg.	2.84±0.62	4.99±1.03	10.10±4.33	47.10±5.8	63.76±10.4	4.07±0.89	2.34±0.60	7.05±3.42	46.11±4.9	66.95±1.5	2.41±0.61	3.99±1.05	7.38±3.66	45.15±5.8	66.04±4.35
F	21.735	33.207	26.414	20.731	2.485	13.851	13.270	22.636	7.721	1.171	24.523	23.477	21.421	13.830	5.298
S	<0.00	<0.00	<0.00	<0.00	<0.018	<0.001	<0.001	<0.001	<0.001	0.321	<0.00	<0.00	<0.00	<0.00	<0.00

As a result of hierarchical cluster analysis, 2 groups have formed in terms of grouping. Sinop-Merkez, Sinop-Ayancık and Karabük-Yenice populations have taken place in the same group in terms of measured all leaf characters, and other populations have created the other group. Formation of two different groups can statistically significant, but according to results of cluster analysis given in Figure 5, 9 different groups can form in terms of leaf characteristics. Distribution on the map of this 9 different groups formed has been given in Figure 6. As can be seen from Figure 6, Düzce-Çiçekli and K.Maraş-Andırın populations have taken place in the same group, another group have been formed by Trabzon-Çaykara and Ordu-Akkuş populations. And remaining 7 groups have been created by other populations.

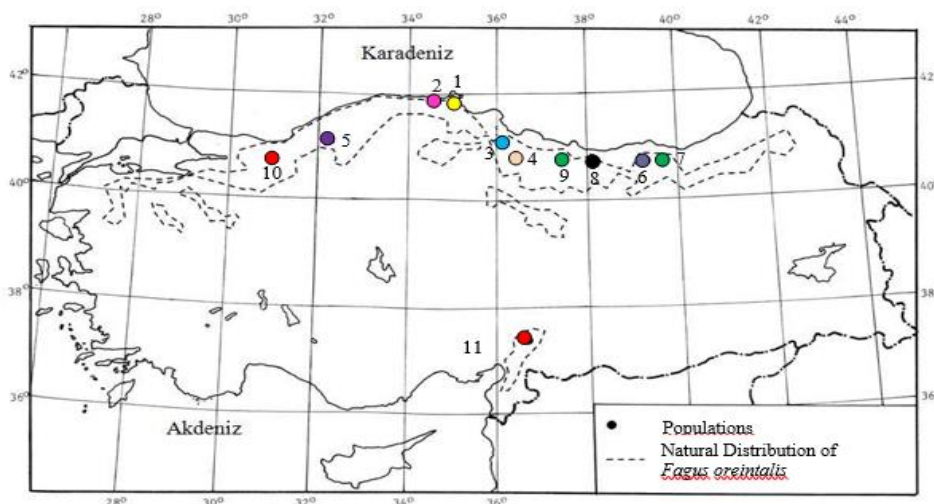

Figure 6. Distribution on the map of groups formed by cluster analysis in terms of leaf width, leaf length, leaf area, leaf vein angle and leaf moisture

#### 4. Conclusions and discussion

In this study, variations within and among populations have been tried to put forward by measuring leaf width, leaf length, leaf area, leaf vein angle and leaf moisture in oriental beech seedlings. Result of the study, it has been determined that leaf width ranged from 2.36 cm to 3.45 cm, leaf length ranged from 3.99 cm to 5.70 cm and leaf area ranged from 6.87 cm<sup>2</sup> to 13.61 cm<sup>2</sup>, leaf vein angle ranged from 43.96 degrees to 48.24 degrees. It has been determined that leaf moisture having values close to each other ranged from % 63.76 to % 68.60.

Variations related to leaf morphology depending on populations has been investigated in another study carried out in *Fagus sylvatica* Lipsky and *Fagus orientalis* L. Result of study carried out by sampling trees in different ages, it has been determined that average of leaf width, leaf length and leaf area respectively 5.16 cm, 8.84 cm and 34.2 cm<sup>2</sup> in *Fagus sylvatica* Lipsky, 4.91 cm, 7.73 cm and 28.8 cm<sup>2</sup> in *Fagus orientalis* L. Variations in terms of measured traits have been detected in both species. This finding has shown a harmony with results obtained in our study. Another study carried out in *Fagus grandifolia* Ehrh., it has been indicated that leaf width ranged from 2.5 cm to 7.5 cm and leaf length ranged from 6 cm to 15 cm (Robert and John, 2004). This result obtained in terms of leaf length in *Fagus grandifolia* Ehrh. has similarity with result obtained in oriental beech.

Sinop-Merkez population has the highest averages in terms of leaf width, leaf length and leaf area. In a study carried out related to production of oriental beech seedlings, it has been reported that total leaf surface is an important factor for growth and it affects positively growth (Tengiz, 1986).

There are numerous studies about variations determined depend on morphological and genetic characteristics of leaf. 13 years old seedlings that grown from seeds collected from 7 different populations have been used in order to investigate morphological and physiological variations related to leaf in *Fagus crenata*. It has been determined that there are significant differences in terms of some traits such as vein elements, the number of veins in mm<sup>2</sup>, average vein area, transpiration rate, leaf area, leaf thickness, leaf dry weight among origins in study. In addition, it has been revealed that meaningful relationships between morphological and physiological properties related to leaf in the study (Bayramzadeh et al., 2008). Variations belong to leaf have determined in other studies made for the same species. And it has been reported that this difference originates from differences in the origins. Additionally, it has been indicated that maximum photosynthesis rate has a positive correlation with leaf thickness (Hiura et al., 1996; Koike, and Maruyama, 1998).

Hiura et al. (1996), in their study made for *Fagus crenata*, have indicated that variations related to leaves of seedlings, obtained from different origins and planted in the same field, result from genetic variation of seed resources. These findings have shown a consistence with findings obtained from our study. Accordingly, for leaf lengths depending on determination of variations within and among populations can be said that closely related with growth and development of seedlings.

## Suggestions

An efficient tree breeding program is aimed that knowing of genetic structures of existing forest trees in nature. For this aim, it is firstly necessary to determination of geographical variations. And then, it is required that detection of genetic structure. Thus, superior and different individuals are protected for future use. On the other hand, with seed and seedling material obtained from these, it is intended to be used in afforestation efforts by going to mass production.

Determination of variations of species should be made as soon as possible to achieve mentioned objective. For this reason, for species should be done measures on some qualitative and quantitative characters. Recently, isoenzyme, DNA, etc. methods has been used in determination of genetic structure together with developing technology. However, such studies cannot be made without laboratory facilities. And they are expensive studies and require attention.

In this study, determination of variation within and among populations of oriental beech, has been carried out based on the measurement of morphological characters of leaves. Result of study, for oriental beech having optimal distribution among 700-1800 m altitudes, both in optimal distribution areas and outside these areas for natural populations, it has been revealed that show variations within and among populations.

For selected populations in this study, it has been determined that variation within populations is greater than among populations. Therefore, source of variation should be sought within populations rather than among populations. For this objective, populations having variation should be examined in detail with DNA, isoenzyme etc. on the basis of individual. And so, the main source of variation should be identified and continuity should be ensured.

Sinop-Ayancık population and especially Sinop-Merkez population remain outside the optimal natural range in terms of altitude for oriental beech and they have had clearly variations. For this reason, conservation of genetic resources is important in terms of the continuity of variation, and therefore the preservation of biodiversity. The continuation of genetic variation should be provided ensuring protection of existing populations.

## References

- Anonymous 2014. Turkey Forests, Republic of Turkey, General Directorate of Forestry, Ankara.
- Bayramzadeh, V., Funada, R. and Kubo, T. 2008. Relationships between vessel element anatomy and physiological as well as morphological traits of leaves in *Fagus crenata* seedlings originating from different provenances, *Trees*, 22, 217-224.
- Chmura, D. J., Rozkowski, R. 2002. Variability of beech provenances in spring and autumn phenology, *Silvae Genetica* 51, 2-3.
- Ertekin, M., Kırdar, E., Ayan, S. 2015. The Effects of Exposure, Elevation and Tree Age on Seed Characteristics of *Fagus orientalis* Lipsky. *South-east Eur for* 6 (1): 15-23. DOI: <http://dx.doi.org/10.15177/see-for.15-03>
- Hiura, T., Koyama, H. and Igarashi, T. 1996. Negative trend between seed size and adult leaf size throughout the geographical range of *Fagus crenata*, *Ecoscience*, 3, 226-228.
- Işık, K. 1981. Domestication of plants and exotic species in terms of domestication, Symposium of Industrial Afforestation with Fast Growing Species in Turkey Kefken-İzmit, 249-254.
- Işık, K. 1988. Importance of local races and genetic contamination problems in our forest tree species, *Journal of Forest Engineering*, 25, 11, 25-30.
- Işık, K., Yıldırım, T. 1990. Strategies for Conservation of Forest Gene Resources and Some Recommendations on *Cedrus libani*. (in: Proc. Of International Cedar Symposium), Supported by FAO and Turkish Forest Service, 22-27 October 1990, Antalya-Turkey, 342-352.
- Kaya, Z. 1989. Genetic Compatibility, Seed Resource and Seed Transfer, *Journal of Seedling*, General Directorate of Forestry, Journal of Occupational Officers Association, 17, 3-8.
- Kaya, Z. 1990. Our Forest Genetic Resources: Our National Heritage, *Journal of Seedling*, General Directorate of Forestry, Journal of Occupational Officers Association, 28, 2-6.
- Koike, T., Maruyama, Y. 1998. Comparative ecophysiology of the leaf photosynthetic traits in Japanese beech grown in provenances facing the Pacific Ocean side and the sea side of Japan. *J Phytogeogr Taxon*, 46, 23-28.
- Namkoong, G. 1989. System of Gene Management. In: *Breeding Tropical Trees: Population Structure and Genetic improvement Strategies in Clonal and Seedling Forestry*. (Proc. IUFRO Conference, Pattaya, Tailand.) Gibson, G.I., Griffin, G.I., Griffin, A.R. and Matheson, A.C. (Editors). Oxford Forestry Institute, Oxford, U.K.
- Robert, R., John, P. 2004. The Ecology and Silviculture of American Beech (*Fagus grandifolia* Ehrh.): An Overview, Improvement and Silviculture of Beech, Proceedings from the 7th International Beech Symposium IUFRO Research Group, 10-20 May, Tehran, Iran.
- Tengiz, E. 1986. Some Features of Oriental Beech (*Fagus orientalis* Lipsky.) and shelter demand in seedling production, *Journal of Forest Engineering*, 23, 3.
- Yahyaoglu, Z., Genç, M. 2007. Seedling Standardization, Süleyman Demirel University, Faculty of Forestry, Issue No. 75, Isparta.
- Zobel, B. and Talbert, S., 1984. Applied Forest Tree Improvement. North Carolina State University. Wiley and Sons. Inc. NY.

(Received for publication 14 March 2016; The date of publication 15 August 2016)



## Comparison of differently originated oriental beech (*Fagus orientalis* Lipsky) seedling growth in field

Deniz GÜNEY <sup>\*1</sup>, İbrahim TURNA<sup>1</sup>, Ali BAYRAKTAR <sup>1</sup>, Erhan SEYİS <sup>2</sup>, Ebru ATAR <sup>1</sup>

<sup>1</sup> Department of Forestry, Karadeniz Technical University, 61080, Trabzon, Turkey

<sup>2</sup> Department of Forestry, Yenice Vocational High School, Çanakkale 18 Mart University, 17550, Çanakkale, Turkey

### Abstract

It is not possible to make artificial regeneration and afforestation areas optimum totally because of the fact that site area conditions have very different characteristics regionally. Based on these ecological conditions where seed origins and application area should be considered. Within the study, it is aimed to examine the land performances of seedlings grown from different origins. For this purpose, 11 natural populations were chosen from natural distribution oriental beech. The seedlings were sowed appropriate to the randomized blocks design with 3 replications.

After grown along two vegetation period in nursery, Trabzon-Maçka, Trabzon-Çaykara, Düzce-Çiçekli, Giresun-Kulakkaya, Ordu-Akkuş and Kahramanmaraş-Andırın populations were planted in the 1230 meters altitude experimental forest in Tonya-Kalıncam. Sinop-Merkez, Sinop-Ayancık, Samsun-Kunduz, Samsun-Karapınar and Karabük-Yenice populations were grown in Of forest nursery for along three vegetation period and then they were planted on the same area. After a vegetation period in the area conditions, morphological measurements such as seedling height, root collar diameter and branch number were made on population and tree basis.

By making variation analysis with the SPSS 20 statistic program, it was determined that these measurements variations within and among populations. It was found that variations in populations are more than variations among populations in terms of morphological characters. On the other hand, populations were grouped with hierarchical cluster analysis.

**Key words:** Oriental beech, field performance, variation, origin, seedling

----- \* -----

## Farklı orijinli doğu kayını (*Fagus orientalis* Lipsky) fidanlarının arazideki büyüme performanslarının karşılaştırılması

### Özet

Yetiştirme ortamı koşullarının yöresel olarak çok farklı özelliklere sahip olması nedeniyle yapay gençleştirme ve ağaçlandırma sahalarının bütünüyle optimum hale getirilmesi mümkün olmamaktadır. Buna bağlı olarak tohumun toplandığı alanlar ile fidanın üretildiği ve dikildiği alanlarının ekolojik koşulları dikkate alınmalıdır. Bu çalışma kapsamında Doğu Kayınının (*Fagus orientalis* Lipsky.) farklı orijinlerinden toplanan tohumlardan yetiştirilen fidanların arazi performanslarını incelemek amaçlanmıştır. Bunun için ülkemizdeki doğal yayılış alanları temsilen seçilen 11 doğal populasyon kullanılmıştır. Tohumlar Of Orman Fidanlığında raslantı blokları deneme desenine uygun olarak 3 tekrarlı ekilmiştir.

Trabzon-Maçka, Trabzon-Çaykara, Düzce-Çiçekli, Giresun-Kulakkaya, Ordu-Akkuş ve Kahramanmaraş-Andırın populasyonları iki vejetasyon dönemi boyunca fidanlıkta yetiştirildikten sonra Tonya-Kalıncam mevkiindeki 1230 metre yükseltideki deneme alanına populasyon bazında dikilmişlerdir. Sinop-Merkez, Sinop-Ayancık, Samsun-Kunduz, Samsun-Karapınar ve Karabük-Yenice populasyonları üç vejetasyon dönemi Of Orman fidanlığında yetiştirildikten sonra ağaç bazında aynı araziye dikilmişlerdir. Arazi koşullarında bir vejetasyon dönemi geçtikten sonra fidanlarda populasyon ve ağaç bazında; fidan boyu, kök boğazı çapı ve yan dal sayısı gibi morfolojik ölçümler yapılarak populasyon içi ve arası varyasyonlar belirlenmeye çalışılmıştır.

Elde edilen verilerle, SPSS istatistik programı ile varyans analizi yapılarak ölçülen karakterler bakımından populasyonlar içinde ve arasında genetik varyasyonların olduğu belirlenmiştir. Çalışma sonucunda ölçülen karakterlerin

\* Corresponding author / Haberleşmeden sorumlu yazar: Tel.: +90462772877; Fax.: +9062257499; E-mail: d\_guney61@hotmail.com

birçoğu bakımından populasyonlar içerisindeki varyasyonun, populasyonlar arasındaki varyasyondan daha fazla olduğu tespit edilmiştir. Bunun yanında ölçülen değişkenlere ilişkin olarak oluşan grupları ortaya koymak için hiyerarşik cluster analizi yapılmıştır.

**Anahtar kelimeler:** Doğu Kayını, arazi performansı, varyasyon, orijin, fidan

## 1. Introduction

A large part of Turkey's forests is unable to provide the benefits expected from them in terms of both quantity and quality, because of the fact that they have been exposed to various forms of degradation until today.

Oriental beech (*Fagus orientalis* Lipsky) is an important tree species for forestry in our country. Thus, the ecological characteristics of planting areas and seedlings to be used in afforestation efforts should be well known (Ertekin et. al., 2015).

The need for forest products is increasing in our country, but it is becoming harder for our existing forests to meet this need. Economy of our country is adversely affected ensuring these needs through imports from other countries. It will be needed more afforestation to overcome deficit of wood raw material, to prevent water and wind erosion that substantially threatening agricultural areas, to ensure the continuity of these areas, to make efficient unproductive forest areas in our country, also to eliminate soil and water pollution occurred as a result of industrialization. Afforestation efforts have intensified in order to eliminate these disadvantages especially since the last 25 years in our country (Sakıcı and Ayan, 2016).

The most effective way to increase the effectiveness of forestry in the national income is to make productive many efficient forest areas that are still no producing and degraded. According to some calculations, it is possible to increase the current efficiency several times more in this way.

Afforestation investments are expensive and long-term investments. It should be used seeds and seedlings that have superior genotypic characteristics in order to guarantee the future of these investments. Besides, regarding selection of the area to use this material needs care in determining seeding and planting methods. Afforestation investments that require great financial devotion must be given great importance in terms of ecologically and technically healthy, socially acceptable and economically reliable. Quality nursery works are of great importance in order to conduct the most economic afforestation efforts and to obtain the highest success especially in unproductive areas.

Within this study it is aimed to examine the land performances of seedlings grown by seeds collected from different origins of *Fagus orientalis*. For this purpose, 11 natural populations were chosen from natural distribution areas of oriental beech in Turkey.

## 2. Materials and methods

In this study, 11 natural oriental beech populations, represented the natural range of oriental beech in Turkey, were selected as the study material. Seedlings grown by seeds collected from a total of 225 trees including average of 20 trees from each of these populations were used.

### 2.1. Determination of sample populations

In accordance with to the research objectives, 11 oriental beech populations, which are able to represent Turkey, were selected. Accordingly, it was made measurements on seedlings grown by seeds collected from Sinop-Merkez, Sinop-Ayancık, Samsun-Kunduz, Samsun-Karapınar, Karabük-Yenice, Düzce-Çiçekli, Trabzon-Maçka, Trabzon-Çaykara, Giresun-Kulakkaya, Ordu-Akkuş and Kahramanmaraş-Andırın populations. Some informations related to sites of populations collected seed material were given in Table 1, and the geographical location of the populations were given in Figure 1.

### 2.2. Measurements related to seedlings

After grown along two vegetation period in nursery, Trabzon-Maçka, Trabzon-Çaykara, Düzce-Çiçekli, Giresun-Kulakkaya, Ordu-Akkuş and Kahramanmaraş-Andırın populations were planted in the 1230 meters altitude sample plot in Tonya-Kalınçam. Sinop-Merkez, Sinop-Ayancık, Samsun-Kunduz, Samsun-Karapınar and Karabük-Yenice populations were grown in Of forest nursery for along three vegetation period and then they were planted on the same area. After a vegetation period in the area conditions, variations within and among populations were tried to determine as made morphological measurements such as seedling height, root collar diameter and number of side branch have been done on population and tree basis..

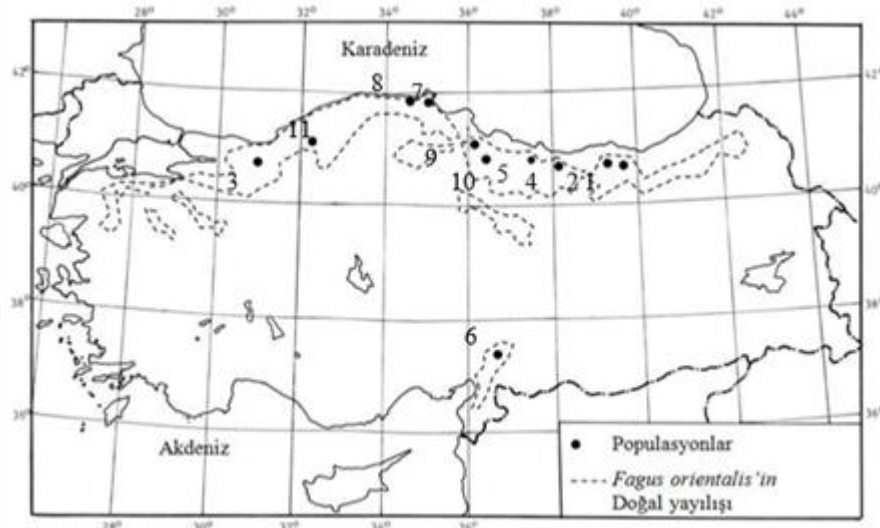

Figure 1. The geographical location of the populations collected seed material

Table 1. Information on the populations

Pop No	Name of Population	Tree Number (N)	* East Longitude	* North Latitude	Altitude	Aspect Groups
1	Trabzon Maçka	19	536104-537264	4502315-4502863	1510-1650	N, NE, NW, E, SW, W
2	Trabzon Çaykara	18	602433-603016	4504412-4506099	920-1485	NE, E, S, SW, SE, W
3	Düzce Çiçekli	20	853080-855918	4507317-4508900	1310-1405	N, NE, NW
4	Giresun Kulakkaya	18	442625-452537	4503642-4504163	455-1460	N, NE, W, S
5	Ordu Akkuş	23	331483-331845	4519805-4520234	1200-1315	N,NE,NW,E S, SE, SW
6	K.Maraş Andırın	20	269188-272115	4175208-4185518	1395-1740	N, NE, NW, E, SE,W
7	Sinop Merkez	21	646426-645002	4530786-4531627	90-140	N, NW, E, S, SW
8	Sinop Ayancık	26	644126-647212	4633190-4635389	605-745	N, NE, NW, E, S, SW
9	Samsun Kunduz	20	666533-665881	4559311-4559075	1300-1390	N, NE, NW
10	Samsun Karapınar	20	685470-685433	4549004-4549406	1250-1360	N, NE
11	Karabük Yenice	20	452653-457710	4566618-4576555	610-1100	N, NE, NW, E, S, SW

\* The coordinates of populations were taken by the UTM coordinates system.

### 3. Results

After grown along two vegetation periods in nursery, Trabzon-Maçka, Trabzon-Çaykara, Düzce-Çiçekli, Giresun-Kulakkaya, Ordu-Akkuş and Kahramanmaraş-Andırın populations were planted for field experiments as tree based in sample plot. The average seedlings height (SH), root collar diameter (RCD) and number of side branch (NSB) values in the 2 + 1 years-old seedlings grown on the land during a vegetation were given together with the standard deviation in Table 2. It was tested by analysis of variance whether difference with regard to measured morphological characteristics in among populations of 2 + 1 years-old seedlings. And then, grouping was performed by Duncan test (Table 2). According to analysis of variance, it was determined that statistically (with % 99 confidence level) differences related to seedling height, root collar diameter and number of side branch in among populations. After these differences were determined, groupings formed by populations were exhibited by Duncan test. As a result, 5 different groups occurred in terms of seedling height. Ordu-Akkuş population was had the highest value with 38.7 cm, and Düzce-Çiçekli population was had the lowest value with 19.4 cm in terms of the average seedling height, and so they occurred two different groups. At the same time, Trabzon-Maçka and Trabzon-Çaykara populations were located in the same group in terms of seedling height. K.Maraş-Andırın and Giresun-Kulakkaya populations were taken place in the other groups.

Table 2. The results of the analysis of variance and Duncan test related to characteristics of 2 + 1 years-old seedlings in among populations

Pop. No	Avg. SH (mm)	Groups	Avg. RCD (mm)	Groups	Avg. NSB (pieces)	Groups
Trabzon-Maçka	33,6±11,0	b	7,1±2,3	b	4,2±2,4	bc
Trabzon-Çaykara	34,3±13,3	b	6,8±2,1	bc	4,4±2,9	b
Düzce-Çiçekli	19,4±6,2	e	4,9±1,6	e	3,1±2,3	e
Giresun-Kulakkaya	28,1±11,1	c	6,5±2,3	c	3,9±2,7	cd
Ordu-Akkuş	38,7±11,8	a	7,8±2,0	a	6,4±2,8	a
K.Maraş-Andırın	22,6±9,7	d	6,1±2,2	d	3,7±2,1	d
Avg.	30,4±12,8		6,6±2,3		4,4±2,8	
Anova results	F : 114.59 (P): 0.000**		F : 53.453 (P): 0.000**		F : 51.241 (P): 0.000**	

\*\* There is difference as statistically. Significance level  $P < 0.01$

Six different groups occurred in terms of root collar diameter. Ordu-Akkuş population was had the highest value with 7.8 cm, and Düzce-Çiçekli population was had the lowest value with 4.9 cm, and so they occurred two groups just as seedling height. Additionally, same situation arose in terms of the number of side branches having 6 different groups. Ordu-Akkuş population was had the highest average number of side branch with 6.4 and Düzce-Çiçekli population was had the lowest average number of side branch with 3.1.

After grown during three vegetation periods in nursery, Samsun-Kunduz, Samsun-Karapınar, Karabük-Yenice, Trabzon-Maçka and Giresun-Kulakkaya populations were planted as population based in the sample plot. The average seedlings height, the average root collar diameter and the average number of side branch values and Duncan test results with analysis of variance in the 3 + 1 years-old seedlings were given in Table 3.

Table 3. The results of the analysis of variance and Duncan test related to characteristics of 3 + 1 years-old seedlings in among populations

Pop. No	Avg. SH (mm)	Groups	Avg. RCD (mm)	Groups	Avg. NSB (pieces)	Groups
Sinop-Merkez	74.4±15,4	a	11.4±3.3	b	9,2±4.0	a
Sinop-Ayancık	82,5±25.6	a	13.6±3.4	a	9.5±4.4	a
Samsun-Kunduz	42.9±13.6	c	8.1±3.2	c	6.0±3.0	b
Samsun-Karapınar	53.4±18.0	b	10.7±2,8	b	9.7±3.9	a
Karabük-Yenice	56.2±16.3	b	10.2±3.4	b	8.6±4.4	a
Avg.	61.9±23.1		10.8±3.7		8.6±4.1	
Anova results	F : 23.55 (P): 0.000**		F : 11.32 (P): 0.000**		F : 4.40 (P): 0.002**	

\*\* There is difference as statistically. Significance level  $P < 0.01$

According to analysis of variance, it was determined statistically differences related to seedling height, root collar diameter and number of side branch in 3 + 1 years-old seedlings. Groupings occurred by populations were revealed by the Duncan test. As a result, 3 different groups occurred in terms of seedling height. Sinop-Ayancık and Sinop-Merkez populations were taken place with regard to seedlings height with values of 82.5 cm and 74.4 cm, respectively, in the same group. Samsun-Kunduz population was had the lowest average value with 42.9 cm. Samsun-Karapınar and Karabük-Yenice populations were taken place in the same group, and they constituted the third group. Three different groups occurred in terms of root collar diameter. Sinop-Ayancık population was had the highest value with 13.6 cm and Samsun-Kunduz population was had the lowest value with 8.1 cm, and so they occurred two different groups with these root collar diameter values. And then, Sinop-Merkez, Samsun-Karapınar and Karabük-Yenice populations were taken place in the same group.

Two groups occurred in terms of number of side branches. Sinop-Merkez, Sinop-Ayancık, Samsun-Karapınar and Karabük-Yenice were taken place in the same group by taking values close to each other. Samsun-Kunduz population with the lowest average in terms of number of side branches occurred second group.

Within Trabzon-Maçka, Trabzon-Çaykara, Düzce-Çiçekli, Giresun-Kulakkaya, Ordu-Akkuş and K.Maraş-Andırın populations transferred as tree based to area, the averages related to characteristics of 2 + 1 years-old seedlings were given in Table 4. It was tried to determine variations within population depending on the results of analysis of variance related each population evaluated in itself (Table 4).

Significance level as shown in Table 4, in the results of analysis of variance was determined to be smaller than 0.01 for each population. Accordingly, it can be said that each population shown statistically differ in terms of seedling characteristics in 2 + 1 years-old seedlings within populations as well as among populations.



Table 4. The results of analysis of variance belong to 2 + 1 years-old seedlings characters within populations

Pop	Trabzon-Maçka			Trabzon-Çaykara			Düzce-Çiçekli			Giresun-Kulakkaya			Ordu-Akkuş			Kahramanmaraş-Andırın		
	sh	rcd	nsb	sh	rcd	nsb	sh	rcd	nsb	sh	rcd	nsb	sh	rcd	nsb	sh	rcd	nsb
1	39,	8,6	5,8	21,	5,9	3,2	19,	5,5	2,4	28,	6,1	3,1	42,	7,2	5,1	21,	5,8	3,6
2	39,	8,5	5,7	31,	6,0	2,2	18,	4,6	1,5	24,	5,6	3,4	47,	9,3	8,0	25,	6,7	4,2
3	27,	5,9	2,8	32,	6,8	5,0	17,	4,9	3,3	29,	6,9	3,7	38,	8,5	4,7	14,	3,5	2,3
4	29,	6,4	3,7	41,	7,6	7,0	20,	4,6	4,2	18,	4,6	2,5	33,	7,2	6,6	16,	5,8	3,2
5	33,	9,3	4,2	47,	8,1	5,4	18,	5,3	2,7	29,	7,7	4,4	43,	6,8	6,7	18,	5,7	2,3
6	35,	6,3	3,6	35,	7,4	4,8	19,	5,8	3,7	45,	9,0	7,5	42,	7,7	6,8	17,	4,2	2,6
7	39,	7,3	5,0	28,	6,7	4,4	18,	4,2	1,9	27,	7,4	4,3	37,	7,8	7,3	41,	9,5	5,9
8	31,	5,8	4,2	32,	6,3	4,4	15,	3,7	1,9	23,	5,8	3,1	41,	8,5	7,5	19,	5,2	2,3
9	40,	6,9	4,5	31,	6,6	2,9	16,	3,5	2,2	-	-	-	29,	7,1	5,5	27,	7,6	5,1
10	27,	6,3	2,7	39,	7,1	5,5	26,	6,7	5,3	-	-	-	32,	7,7	5,4	25,	6,2	3,9
11	-	-	-	30,	6,1	2,9	19,	4,5	3,4	-	-	-	-	-	-	-	-	-
Avg.	34,	7,2	4,2	34,	6,8	4,4	19,	4,9	3,1	28,	6,5	3,9	38,	7,8	6,4	22,	6,1	3,6
F	6	10.	6.7	3	3.3	8.4	4	10.	6.6	1	14.	11.	7	4.8	5.0	5	21.	9.1
P	9.0	6	9	9.4	4	7	5.5	8	9	23.	3	3	7.5	6	7	26.	8	4
Gro	7	0.0	0.0	1	0.0	0.0	0	0.0	0.0	7	0.0	0.0	3	0.0	0.0	9	0.0	0.0

\*\* There is difference as statistically. Significance level  $P < 0.01$ ; Group: The number of groups formed as a result of Duncan test

After determining differences within populations, with Duncan test, it was determined how many different groups exist according to seedling height, root collar diameter and number of side branch. According to this, Trabzon-Maçka population occurred 6 different groups in terms of seedling height, 4 different groups related to root collar diameter and 5 different groups concerning number of side branch. Trabzon-Çaykara population formed 7 different groups in terms of seedling height, 5 different groups related to root collar diameter and 7 different groups concerning number of side branch. Düzce-Çiçekli population created 2 different groups in terms of seedling height, 8 different groups related to root collar diameter and 11 different groups concerning number of side branch. Giresun-Kulakkaya population formed 5 different groups in terms of seedling height, 7 different groups related to root collar diameter and 4 different groups concerning number of side branch. Ordu-Akkuş population occurred 5 different groups in terms of seedling height, 4 different groups related to root collar diameter and 6 different groups concerning number of side branch. Kahramanmaraş-Andırın population created 6 different groups in terms of seedling height, 7 different groups related to root collar diameter and 5 different groups concerning number of side branch.

A statistical analysis was made by hierarchical cluster analysis as using averages of seedling height, root collar diameter and number of side branch in order to determine how populations involved in a grouping. It was given groupings of 2 + 1 years-old seedlings, with cluster analysis, in Figure 2.

While Trabzon-Maçka, Trabzon-Çaykara and Ordu-Akkuş populations were taken place in the same group, Düzce-Çiçekli and K.Maraş-Andırın populations occurred another group. Giresun-Kulakkaya population alone created third group. Distribution on the natural distribution areas of oriental beech for these groups was given in Figure 3. It was shown populations into the same group with the same color.

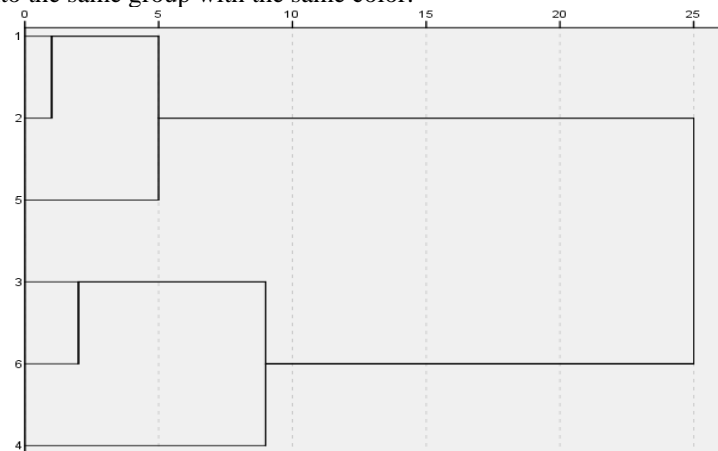

1: Trabzon-Maçka, 2: Trabzon-Çaykara, 3: Düzce-Çiçekli, 4: Giresun-Kulakkaya, 5: Ordu-Akkuş 6: K.Maraş-Andırın

Figure 2. Groups occurred by cluster analysis in terms of seedling height, root collar diameter and number of side branch in 2 + 1 years-old seedlings.

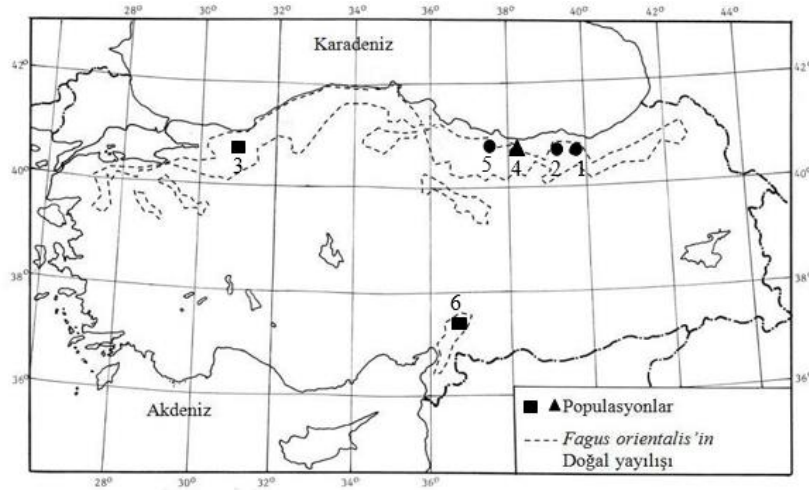
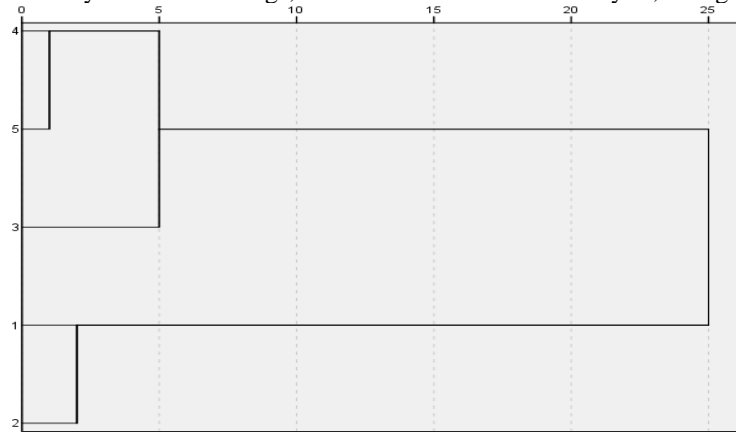

Figure 3. Distribution on the map of groups occurred by cluster analysis in terms of seedling height, root collar diameter and number of side branch in 2 + 1 years-old seedlings

It was shown groupings of 3 + 1 years-old seedlings, with hierarchical cluster analysis, in Figure 4.



1: Sinop-Merkez, 2: Sinop-Ayancık, 3: Samsun-Kunduz, 4: Samsun-Karapınar, 5: Karabük-Yenice

Figure 4. Groups occurred by cluster analysis in terms of seedling height, root collar diameter and number of side branch in 3 + 1 years-old seedlings

As it can be seen from Figure 4, whereas Samsun-Kunduz, Samsun-Karapınar and Karabük-Yenice populations were taken place in the same group, Sinop-Merkez and Sinop-Ayancık populations occurred second group. Distribution on the map of these groups was given in Figure 5.

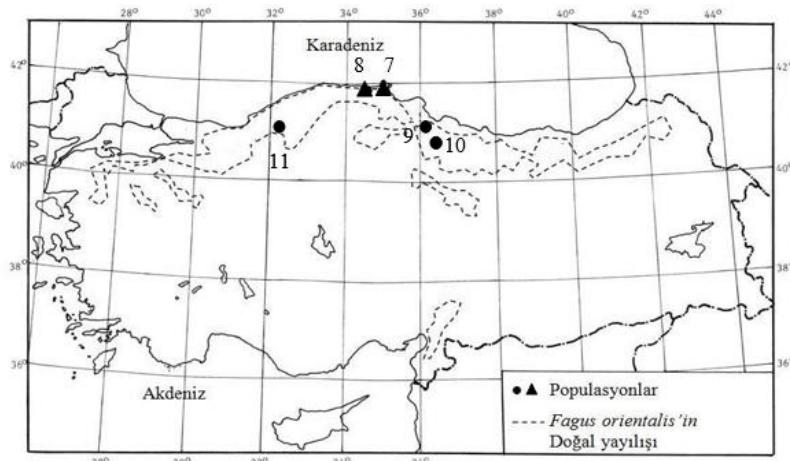

Figure 5. Distribution on the map of groups occurred by cluster analysis in terms of seedling height, root collar diameter and number of side branch in 3 + 1 years-old seedlings

#### 4. Conclusions and discussion

It was determined genetic variations in terms of characters measured by making analysis of variance with the SPSS 20 statistic program within and among populations. On the other hand, populations were grouped with hierarchical cluster analysis in order to reveal groups in relation to measured variables.

As a result of Cluster analysis made for 2 + 1 years-old seedlings, Trabzon-Maçka, Trabzon-Çaykara and Ordu-Akkuş populations were occurred first group, Düzce-Çiçekli and K.Maraş-Andırın populations were generated second group and Giresun-Kulakkaya population was created third group. Then, as a result of Cluster analysis made for 3 + 1 years-old seedlings, Samsun-Kunduz, Samsun-Karapınar and Karabük-Yenice populations were occurred first group, Sinop-Merkez and Sinop-Ayancık populations were generated second group.

There are many studies revealed variation within and among populations related to seedling properties. It was investigated that variations among origins depend on soil moisture content in *Fagus sylvatica* L. seedlings which are represented, grown in greenhouse, 14 different origins. As a result of this study, it was determined that morphological characters such as seedling height and root collar diameter and physiological properties such as starting time and length of the growing period were had differences among origins (Nielsen and Jorgensen, 2003).

Cause of genetic variations in this study can be explained with the fact that oriental beech spread very wide geographic areas in our country and ecological factors in these geographic areas within and among populations (topography, climate, environmental factors, etc.). In other respects, in many studies made in *Fagus sylvatica* L., natural selection and genetic isolation together with differences in environmental factors depending on wide geographical distribution of this species were explained as a cause of genetic variation in beech stands (Belletti, 1996; Thiebaut et al., 1982; Barrière et al., 1985; Cuguen et al., 1985). This situation supports our results.

Studies indicate that wind-pollinated species, such as beech, have high genetic variation. For this species, variation within population is generally higher. But variation among populations does not generally exceed 5% (Larsen, 1996; Leonardi and Menozzi, 1995; Paule et al., 1995). In another study, made by sampling 20 populations with isoenzyme analysis in *Fagus sylvatica* L., it was determined that total genetic variation originated from diversity within population by % 98 and originated from diversity among population by % 2 (Konnert, 1995). In a similar study made by 16 populations in *Fagus japonica*, it was stated that variation among populations was low, but variation within population was high (Hiraoka and Tomaru, 2009b).

Each population was generated by subpopulations generated itself because forest trees can carry a large amount of their seeds to confined area (Işık, 1988). Because of the fact that subpopulation was occurred by different individuals unique to specific environmental conditions of microhabitat and local environmental differences, genetic diversity within population is high here. So, different races and sub-races can occur even in a very short distance. In our country, there are studies revealed existence of different local races in a short distance (Boydak, 1977; Işık, 1979; Aslan and Uğurlu, 1986; Ayan et al., 2016). This situation is similar with oriental beech investigated in this study. Beech seeds are big, and they can germinate under its own shelter. So, beech can create a micro-environment in a very small area.

It is stated that genetic structure of beech stands is attached to natural selection besides gene flow and genetic drift. Furthermore, it was reported in several studies that these factors cause differences within and among populations (Kim, 1979; Müller-Starck, 1985, 1989; Cuguen, 1988; Gregorius, 1986).

The existence of the genetic diversity in a population is considered as an important factor related to adaptation to place where existed the species in the population (Stern, 1974; Hamrick, 1985).

In any time period, interventions made to living populations have genetic effects that continue for tens of thousands of years in further generations. Therefore, rehabilitation efforts and genetic planning are required as a precaution against especially in terms of ensuring the continuity of local races and genetic contamination (Güney, 2009). To effective protection and use of gene resources in sustainable forestry studies, structure and dimension of genetic diversity in natural stands should be well known (Kaya 1990; Millar and Marshall, 1991).

#### Suggestions

Determination of variations within and among populations for oriental beech was made by measurements of the morphological characteristics of the seedlings grown under field conditions. In result of the study for oriental beech, it was revealed that, in optimal distribution areas and outside these areas for natural populations, there are variations within and among populations.

Both altitudinal zones and protection of variation value should be taken care in afforestation efforts made for oriental beech. Using the material that has uncertain origin in afforestation efforts will cause genetic contamination and corruption of high genetic base identified in oriental beech.

Sinop-Ayancık population and especially Sinop-Merkez population showed clearly variations, and remained outside optimal natural distribution areas in terms of elevation of oriental beech. For this reason, conservation of genetic resources in its own place is important for continuity of the variation and consequently preservation of biodiversity. With protection of existing population should be provided continuation of genetic variation.

In the result of this study, Sinop-Ayancık population and especially Sinop-Merkez population have the highest values concerning both root collar diameter and seedling height. These populations were separated itself from other populations by creating a different group in the groupings. Determination of superior properties in terms of seedling characters in Sinop-Merkez population, which is outside natural distribution areas of oriental beech and grown at elevations close to sea level in terms of especially elevation, shows that genetic variation is more here. Accordingly, particularly in these populations, the use of materials unknown origin and therefore genetic base will lead to deterioration of existing genetic wealth in afforestation efforts to do in this region.

The results belonging to applications carried out in particularly forestry activities reveal in the long-term, so using the material having uncertain origin and uncontrolled activities will cause genetic contamination in populations having a rich genetic structure without rehabilitation activities. Individuals, planted in afforestation area by bringing from populations in another region, show various adjustment disorders and even die.

## References

- Aslan, S. and Uğurlu, S. 1986. Seed and Seedlings Characteristics of Different *Pinus brutia* Ten., *Pinus halepensis* Mill. and *Pinus elliottii* Mill. Provenances. F. Res. Inst. Technical Bulletin No 165, Ankara.
- Ayan, S., Ünal, E., Yer, E.N., Sakici, O. E., İslam, A. 2016. Population diversity in Northwest Anatolia Forests in terms of nut characteristics of Turkish hazelnut (*Corylus colurna* L.) (Kastamonu province), International Multidisciplinary Congress of Euroasia, 11-13 July, 2016, Odesa, Ukraine.
- Barrière, G., Comps, B., Cuguen, J., Nitsiba, F., Thiebaut, B. 1985. The genetical ecological variability of beech (*Fagus sylvatica* L) in Europe - an alloenzymatic study: genetic isolations of beechwoods. In: Proc 1st Symp Improvement and Silviculture of Beech. IUFRO Project Group P1 10-00, Grosshansdorf, 24-50.
- Belletti, P., Lanteri, S. 1996. Allozyme Variation among European Beech (*Fagus sylvatica* L.) Stands in Piedmont, North-Western Italy, *Silvae Genetica*, 45.
- Boydak, M. 1977. Pollen movements in the vertical direction and its importance in implementation in natural populations of Scots pine (*Pinus sylvestris* L.). *Journal of Faculty of Forestry Istanbul University*, 27, 2, 226-238.
- Cuguen, J., Thiebaut, B., Nitsiba, F. and Barrière, G. 1985. Enzymatic variability of beech stands (*Fagus sylvatica* L) on three scales in Europe: evolutionary mechanisms. In: Genetic Differentiation and Dispersal in Plants (Jacquart P, Heim G, Antonovics J, eds) NATO ASI Series, Montpellier, 17-39.
- Cuguen, J., Merzeau, D., Thiebaut, B. 1988. Genetic structure of the European beech stands (*Fagus sylvatica* L.): F-statistics and importance of mating system characteristics in their evolution, *Heredity*, 60, 91-100.
- Ertekin, M., Kırdar, E., Ayan, S. 2015. The Effects of Exposure, Elevation and Tree Age on Seed Characteristics of *Fagus orientalis* Lipsky. *South-east Eur for* 6 (1): 15-23. DOI: <http://dx.doi.org/10.15177/see-for.15-03>
- Gregorius, H.R., Krauhaussen, J. and Müller-Starck, G. 1986. Spatial and temporal differentiation among the seeds in a stand of *Fagus sylvatica* L. *Heredity*, 56, 255-262.
- Güney, D. 2009. Morphogenetic Determination of the Some Geographic Variation in *Fagus orientalis* Lipsky, KTU Institute of Natural Sciences, PhD., Trabzon.
- Hamrick, J. L., Schnabel, A. 1985. Understanding the genetic structure of plant populations: Some old problems and a new approach. Gregorius, H.-R. (ed.) In *Population Genetics in Forestry, Lecture Notes in Biomathematics* 60, Springer-Verlag, 50-70.
- Hiraoka, K. and Tomaru, N. 2009b. Population genetic structure of *Fagus japonica* revealed by nuclear microsatellite markers, *Int. J. Plant Sci.* 170,6, 748-758.
- İşık, K. 1979. Origin Experiments: definition, types and the principles considered in collecting seed. *Journal of Forest Engineering*, March-April, 7-15.
- İşık, K. 1988. Importance of local races and genetic contamination problems in our forest tree species, *Journal of Forest Engineering*, 25, 11, 25-30.
- Kaya, Z. 1990. Forest Genetic Resources in Turkey: Our National Heritage, *Journal of Seedling*, General Directorate of Forestry 28, 2-6.
- Kim, Z. S. 1979. Inheritance of leucine aminopeptidase and acid phosphatase isoenzymes in beech (*Fagus sylvatica* L). *Silvae Genet.* 28, 68-71.
- Konnert, M., 1995. Investigations on the genetic variation of beech (*Fagus sylvatica* L.) in Bavaria. *Silvae Genetica*, 44, 346-351.
- Larsen, A. B., 1996. Genetic structure of populations of beech (*Fagus sylvatica* L.) in Denmark, *Scandinavian Journal of Forest Research*, 11, 3, 220-232.
- Leonardi, S., Menozzi, P. 1995. Genetic variability of *Fagus sylvatica* L. in Italy: the role of postglacial recolonization. *Heredity*, 75, 35-44.
- Millar, C. I. and Marshall, K. A. 1991. Allozyme variation of port-orford-cedar (*Chamaecyparis lawsoniana*): implications for genetic conservation. *Forest Sci.* 37, 1060-1075.
- Müller-Starck, G., 1985. Genetic differences between "tolerant" and "sensitive" beeches (*Fagus sylvatica* L) in an environmentally stressed adult forest stand. *Silvae Genet.* 34, 241-247.

- Müller-Starck, G. 1989. Genetic implications of environmental stress in adult forest stands of *Fagus sylvatica* L. In: Genetic effects of air pollutants in forest tree populations (Scholz F, Gregorius HR, Rudin D, eds) Springer, Berlin, 127-142.
- Nielsen, N. C., Jorgensen, F. V. 2003. Phenology and diameter increment in seedlings of European beech (*Fagus sylvatica* L.) as affected by different soil water contents: variation between and within provenances, *Forest Ecology and Management*, 174, 233-249.
- Paule, L., Gömöry, D., Vysny, J. 1995. Genetic diversity and differentiation of beech populations in Eastern Europe. In: S. F. MADSEN (Ed.), *Genetics and Silviculture of Beech*. *Forskningserien*, 11, 159-167.
- Sakıcı, O. E., Ayan, S. 2016. Türkiye, Azerbaycan ve Orta Asya Türk Devletlerinin orman varlıkları bakımından karşılaştırılması, *Türk Dünyası İlimi Araştırmalar Sempozyumu*, 29-30 Mayıs, 2016, Celalabat, Kırgızistan.
- Stern, K., Roche, L. 1974. *Genetics of Forest Ecosystems*. Springer-Verlag, Berlin, Heidelberg, New York.
- Thiebaut, B., Lumaret, R. and Vernet, P., 1982. The bud enzymes of beech (*Fagus sylvatica* L). Genetic distinction and analysis of polymorphism in several French populations. *Silvae Genet*, 31, 51-60.

*(Received for publication 18 September 2015; The date of publication 15 August 2016)*

**The beech (*Fagus orientalis* Lipsky) diameter frequency fit with probability distribution in Iran's north forests**Mir Mozaffar FALLAHCHAI <sup>\*1</sup><sup>1</sup> Department of Forestry, Lahijan Branch, Islamic Azad University, Lahijan, Iran**Abstract**

In order to study the quality of the Beech tree diameter at breast height and its fit through the statistical distribution two one hectare sample pieces were randomly selected in a lozenge shape of *Fagus orientalis* Lipsky of natural stand forests in the northern slope of Iran's north forests. In these pieces all trees with more than 7.5 cm diameter were measured according to full callipering. The Beta, Gamma, Weibull, Normal, Lognormal, Exponential and Power statistical models were used in order to fit the data. The results obtained from chi-square test  $\chi^2$  revealed that the Beta distribution in west and east directions and also exponential distribution in the west direction have produced a good fit for trees diameter distribution. But the other distributions didn't show much capability in explaining the studied trees diameter distribution.

**Key words:** fit, statistical distributions, diameter, beech**1. Introduction**

An essential programming on the field of natural resources needs qualitative and quantitative data which is usually obtained by measuring the stand's characteristics (Zobeiri, 2000). Diameter at breast height of trees is one of the most essential characteristics or external sized of forest trees which can be studied from different aspects; for instance the diameter distribution of the trees of a stand or a forest can be determined and considered in which this distribution itself shows the diameter structure of the stand or forest (Mohamed Alizadeh et. al., 2009). In this direction various statistical models are used, because statistical models are among the factors that are used to prepare the growing models for estimating the site's future situation (Mataji et. al., 2000).

The quantity distribution evaluation in a forest's diameter classes by desirable probability theories is not only important for product type evaluation but also it could be beneficial for forest programming (Nanang, 1998). The first effort for modeling the diameter data were done by F.de Licourt in 1898 (Bailey, 1980). In order to do this he used geometrical progression terms with the general term of  $a_n = aq^{1-n}$ . In 1933, also Mayer used the  $y = k^{-ax}$  exponential function for modeling the diameter data (Gardiner, 1968). Almost after the sixtieth decade A.D using statistical distributions in forest studies became customary (Namiranian, 1999.). During his studies in 1988 Shiver in order to fit the Weibull distribution to the diameter information of *Pinus elliottii* (Slash pine) used the three following methods maximum likelihood, modified moments and percentile (Shiver, 1988). In the study in Ghana by Nanang (1998), used three distributions Weibull, Lognormal, Normal, to fit the data related to *Azadirachta indica*. The results obtained from Kolmogorov-Smirnov experiment proved the preference of lognormal distribution to fit the data (Nanang, 1998). In another study that was done on *Pinus teada* (Loblolly pine) the data were collected from 20 sample pieces of 0.62 hectares. In this survey the trees diameter distribution description was made by the help of three parameter Weibull distribution and for forecasting distribution parameters variables such as number of trees in a hectare, prevailing height, stand age and the tree's pertaining distances were used (Cao, 2004). In another study, a model was made for *Fagus* trees diameter distribution by the use of Weibull distribution. This model was based on distribution function parameters and it was made by the use of non-linear least square method (Fallah et al, 2005). In Iran the first studies that were done in this case refer to the tree diameter distribution studies in Noshahr's Khairoud Kenar forest (Namiranian, 1999). In this study the three Beta, Weibull and negative binomial distributions were used. The results obtained from accomplishing goodness fit and Kolmogorov-Smirnov test revealed that the two Weibull and Beta distributions have the ability to describe the trees diameter distribution. Also, Mataji et al. (2000) studied the trees diameter distribution in stands with

\* Corresponding author / Haberleşmeden sorumlu yazar: Tel.: +00981342222602; Fax.: +00981342222602; E-mail: mir\_mozaffar@yahoo.com

different ages in Khairoud forest near Noshahr and got to the result that the tree Beta, Weibull and normal distributions have exciting capability in explaining trees diameter distribution (Mataji et al., 2000). In another study by Fallah et al. (2015) used various regression models to study *Fagus* trees' diameter structure in un-even aged stands. Also, in this study in order to consider the trees' diameter data distribution Beta, Gamma, Weibull, Power Exponential, Normal and Lognormal statistical models were used so that the capability and similarity of these distributions would be revealed for the fit of the diameter data (Nord-Larson Cao, 2006).

## 2. Materials and methods

### 1.1. Study area

Optimum growth conditions for oriental beech are on the north-facing slopes in natural distribution areas (Ertekin et al., 2015). The under study area is located in the north slope of Dorfak peak in Iran's north forests and it is situated in 36°, 54', 22" latitude till 49°, 36', 58" longitude with a minimum 350 meters and maximum 2720 meters height above the sea level. Its entire measurement is 5383 hectares and its central parts have a relatively excessive slope and it is covered with pure *Fagus* forests along with other species. Geologically it belongs to the second and the early third geology periods. Pedagogically it contains forest brown soil type with an origin of calcareous mother rock which P<sub>H</sub> is neutral to weak acidic with a fluctuation between 6.4-6.9. The average annual rain fall of the under study area is 903.7 millimeters and its annual temperature is 16.2 degree centigrade. The relative humidity of this area fluctuates between 74-86 percent. Its climate type according to Emberger's method is temperate humid.

### 1.2. Study method

In order to study the quality of Beech tree diameter at breast height distribution and its fit by means of statistical distributions two one hectare sample pieces with 100×100 meters dimensions in a lozenge shape were randomly selected in the under study area in 1200 meters height above the sea level. These areas are pedagogically and geologically similar and their forests are un-even aged. In these pieces all trees with 7.5 centimeters diameters were one hundred percent measured.

### 1.3. Statistical distributions

In this study Beta, Gamma, Weibull, Normal, Lognormal, Exponential, and Power statistical models (distributions) were used that their probability density function would be introduced here.

Beta distribution:

This distribution is a continuous distribution and it is represented as an integral and its formula is as follows:

$$B(m, n) = \int_0^1 x^{m-1} (1-x)^{n-1} dx$$

In this formula X is the considered feature and m and n are the distribution parameters.

Gamma distribution:

Even this distribution is a continuous distribution and it almost has a good flexibility and its frequency curve in all modes has a lean towards right (Zwillinger and Kokoska, 2000). Its mathematical process is as follows:

Γ: Gamma function symbol

$$F(x) = \frac{x^{\alpha-1} \exp\left(-\frac{x}{\beta}\right)}{\beta^\alpha \Gamma(\alpha)} \quad 0 \leq x < +\infty \quad \alpha, \beta > 0$$

Weibull distribution:

Weibull distribution is also presented as an cumulative frequency in which a is the starting point and b presents the curve's concavity degree, and c is the curve's factor form or shape index and its mathematical process is as follows:

$$F(x) = 1 - \exp\left[-\left(\frac{x-a}{b}\right)^c\right] \quad a, b, c > 0$$

Normal distribution:

Another continuous distribution is Normal distribution which many natural phenomenon's if measured have a close distribution to it as the trees quantity distribution in different diameter classes in a even-age forest stand which has almost a normal distribution. The density function of this distribution is as follows:

$$F(x) = \frac{1}{\delta\sqrt{2\pi}} \exp\left[-\frac{1}{2}\left(\frac{x-\mu}{\delta}\right)^2\right] \quad -\infty < x < +\infty, \mu \in R, \delta > 0$$

Lognormal distribution:

As the other distribution this is also a continuous distribution and its natural logarithm has a normal distribution. This distribution is introduced through the following density function:

$$F(x) = \frac{1}{\sqrt{2\pi}\delta x} \exp\left(-\frac{1}{2\delta^2}(\ln x - \mu)^2\right) \quad \delta > 0, x > 0, 0 < \mu < +\infty$$

Exponential distribution:

This distribution is also known as the time expecting distribution which is a continuous distribution and its mathematical process is as follows:

$$F(x) = \lambda \exp(-\lambda x) \quad \lambda > 0, 0 < x < +\infty$$

Power distribution:

This is another continuous distribution which density function is as follows:

$$F(x) = b \cdot x_i^{b_i} \quad 0 < x < +\infty$$

Goodness of fit study:

In order to choose the best fit it is essential that each of the Beta, Normal, Exponential, Power, Gamma, Weibull and lognormal models to be tested by goodness of fit that in this study chi-square was used as goodness of fit and its mathematical Process is as follows:

$$\chi^2 = \frac{(O - E)^2}{E} \quad O: \text{Observe Frequency} \quad E: \text{Expected Frequency}$$

### 3. Results

Also the tables 1 and 2 show the distribution's accounts results of 411 single trees in 5 cm diameter classes in west direction, and 462 single trees in the east direction of the under study area along with the evaluations obtained from the utilized probability distributions.

Figures 1 and 2 also show the comparison of the observed frequencies and the evaluated frequencies of the probability distributions in the east and west geographical directions.



Table 1. The quantity distribution in the observed diameter levels and their evaluation with probability distribution in west direction

10	99	91.47	83.13	91.23	174.20	62.45	102.79	30.24
15	65	63.23	74.10	71.27	84.54	77.52	93.24	38.87
20	50	50.32	60.52	55.67	50.61	68.62	61.46	45.7
25	40	41.53	47.85	43.49	34	54.95	41.05	49.19
30	37	34.69	37.11	33.97	24.56	41.91	28.42	48.38
35	31	29.04	28.42	26.53	18.66	31.03	20.32	43.52
40	25	24.21	21.55	20.73	14.70	22.55	14.97	35.77
45	16	19.99	16.17	16.19	11.92	16.15	11.28	26.9
50	11	16.25	12.11	12.65	9.88	11.45	8.68	18.49
55	7	12.94	8.98	9.88	8.33	8.05	6.79	11.62
60	8	9.99	6.68	7.72	7.13	5.63	6.79	6.69
65	9	7.37	4.88	6.03	6.19	3.92	4.34	3.53
70	4	5.08	3.59	4.71	5.42	2.70	3.53	1.68
75	4	3.11	2.62	3.68	4.79	1.87	2.90	0.74
80	3	1.49	1.90	2.87	4.27	1.29	2.41	0.30
85	2	0.31	1.38	2.24	3.83	0.88	2.02	0.11

Table 2. The quantity distribution in the observed diameter classes and their evaluation with the probability distributions in the east direction

10	152	129.12	122.79	92.86	215.79	84.31	154.41	35.99
15	88	70.17	86.65	72.58	97.17	93.16	102.81	43
20	50	50.80	63.46	56.72	55.17	77.71	61.53	47.85
25	29	39.92	47.09	44.33	35.56	59.63	39.20	49.51
30	22	32.54	35.22	34.64	24.84	43.95	26.43	47.66
35	28	27.02	26.48	27.08	18.34	30.60	18.60	42.70
40	19	22.67	20	21.16	14.10	22.36	13.56	35.59
45	10	19.07	15.13	16.54	11.19	15.65	10.15	27.58
50	12	16.02	11.49	12.92	9.09	10.85	7.78	19.91
55	11	13.39	8.74	10.10	7.54	7.48	6.09	13.36
60	11	11.07	6.65	7.89	6.35	5.12	4.84	8.36
65	8	9.02	5.08	6.17	5.42	3.50	3.90	4.85
70	8	7.18	3.88	4.82	4.69	2.39	3.19	2.62
75	6	5.51	2.96	3.77	4.09	1.61	2.63	1.32
80	3	4.02	2.27	2.95	3.60	1.09	2.18	0.616
85	3	2.66	1.74	2.30	3.20	0.436	1.83	0.27
90	1	1.46	1.34	1.80	2.86	0.496	1.55	0.107
95	1	0.41	1.03	1.40	2.57	0.333	1.32	0.04

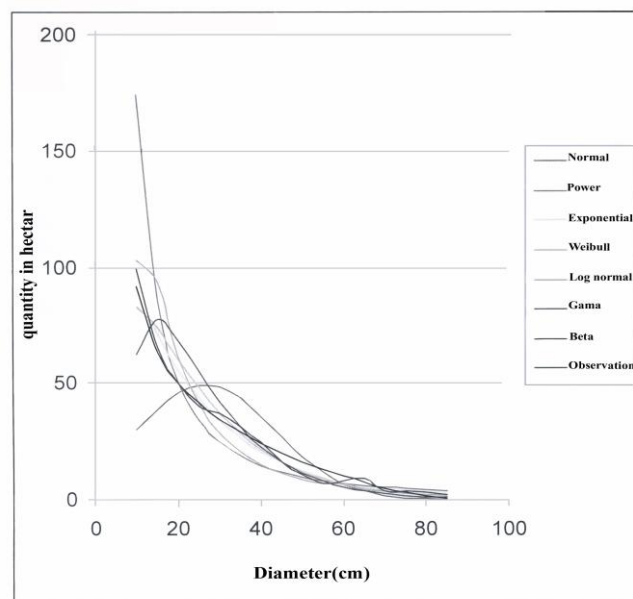

Figure 1. The comparison of observed frequencies and evaluated frequencies of probability distributions in west direction

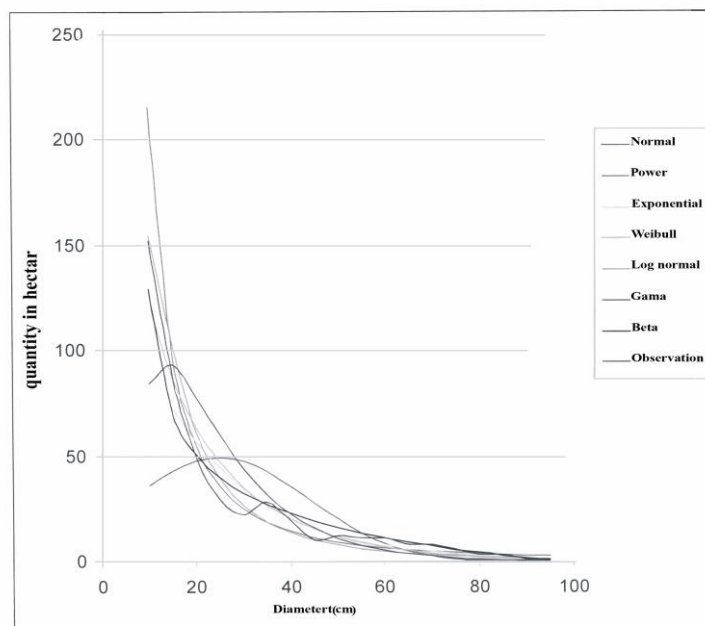

Figure 2. The comparison of the observed frequencies and evaluated frequencies of probability distribution in east direction

As mentioned in order to consider the fit capability of the utilized probability distributions in this study chi-square test was used which the amounts resulting from accomplishing this test are shown in table 3.

Table 3.  $\chi^2$  amounts for the utilized probability distribution in

Distribution type \ Direction	Beta	Exponential	Power	Weibull	Gama	Lognormal	Normal	$\chi^2_c$
West	ns 18.640	ns 6.899	** 64.330	** 14.413	** 47.889	** 36.231	** 277.915	$\chi^2$ , df <sub>16</sub> = 26.296
East	ns 21.90	** 63.127	** 46.473	** 37.444	** 145.395	** 45.951	** 561.714	$\chi^2$ , df <sub>16</sub> = 26.296

\* It is significant in 5% level. ns is no significant. ns = non - significant

According to the quantities that were the outcome of this test (Table 3) it was specified that Beta distribution in the two west and east direction hasn't been significant with the observed frequencies. In other words the observed distributions in the under study area has been a random sample from the community which characteristics are explained through Beta distribution. Therefore since Beta distribution has a lesser  $\chi^2$  in comparison to the  $\chi^2$  of the table it can be considered as a model with a better fit for describing the area's forests. Figures 1 and 2 also show the models for the distribution quantity in different geographical directions. It is observed that Beta model has made a fine fit in distributing the main parts in west and east directions. Of course the Weibull and Exponential models especially exponential model for having lesser  $\chi^2$  has made a very appropriate distribution in west direction and this fit isn't seen in the other direction. Concerning the other probability distributions it has been observed that the difference among Power, Gamma, Lognormal and Normal distribution with real quantities is significant and this means that these distributions don't have high accuracy in order to demonstrate the manner of the trees distribution in different diameter classes.

#### 4. Conclusions and discussion

According to the importance of diameter at breast height as the main biometric variable of the forest trees, the studies on it have a great importance. On the other hand the frequency distribution or the distribution of this variable is also mostly used for determining the stand or forest diameter structure but it can also have other usage such as growing models. In this case, Nanang (1998) think that the usage of appropriate probability distributions is important for the

forecast of trees distribution state in a forest stand. These studies are the same as Namirian (1999) studies in Iran since they explain that Weibull and Beta probability distributions have a greater capability for showing the manner of the trees distribution in different diameter classes. Mataji et. al. (2000) studies also show that the Normal, Weibull and Beta probability distributions have a greater capability to explain the trees diameter distribution. Cao (2004) studies on *Pinus teada* diameter information also explains that using Weibull probability distribution is appropriate. Nord-Larson & Cao (2006), have also used Weibull distribution model in studying *Fagus* diameter distribution. These comparisons show that for achieving an appropriate model for an un-even-aged structure in a forest special attention should be given to the site situations and features. Finally, it is necessary to mention that the results obtained from this study is influenced by its information and necessarily they may be different in order studies.

## References

- Bailey, R. L. 1980. Individual tree growth derived from diameter distribution models. *Forest science*, 26(4):626-632.
- Cao, Q. V. 2004. Predicting parameters of a weibull function for modeling diameter distribution. *Forest Science*, 50 (5):682-685.5.
- Ertekin, M., Kirdar, E., Ayan, S. 2015. The effects of exposure, elevation and tree age on seed characteristics of *Fagus orientalis* Lipsky. *South-east Eur for* 6 (1): 15-23. DOI: <http://dx.doi.org/10.15177/seeфор.15-03>
- Fallah, A, Zobairi, M., Mohajer, M. 2005. Presenting an appropriate quantity distribution model in *Fagus orientalis* natural and different age stands in north of Iran. *Iran's natural resources journal*, 813-821:(4)85
- Gardiner, S.H. 1968. *Forest biometric* (Translation). Pergamon press, Oxford.447p.
- Mataji, A, Hojati, M, Namiranian, M. 2000. The study of quantity distribution in diameter levels in natural forests by using probability distribution. *Iran's Natural Resources Journal*, 53 (2) 165-171.
- Mohamed Alizadeh, KH, Zobeiri, M, Namiraniyan, M, Hourfar, A., Mohajer, M. 2009. Diameter breast height frequency distribution fit by the usage of some statistical models (distributions). *Iranian Journal of Forest and Poplar Research*, 17 (1) 116-124.
- Namiranian, M. 1999. The application of probability theories in determining trees distribution in different diameter levels. *Iran's natural resources journal*, 93-108:44
- Nanang, D.M. 1998. Suitability of the Normal, log-normal and Weibull distribution for fitting diameter distribution of Neem plantations in Northern Ghana. *Forest Ecology and Management*, 103:1-7.
- Nord-Larson, T., Cao, Q.V.A. 2006. Diameter distribution model even-aged beech in Denmark. *Forest Ecology and Management*, 231:218-225.
- Shiver, B.D.1988. Sample size and estimation methods for the Weibull distribution for unthinned Slash pine plantation. *Forest Science*, 34 (3):809-814.
- Zobeiri, M. 2000. *Inventory in the forest*. Tehran university publication, 401p.
- Zwillinger, D., Kokoska, S. C.R.C. 2000. *Standard probability and statistics table formulae*. Chapman & Hall/CRC, 554 P.

*(Received for publication 17 September 2015; The date of publication 15 August 2016)*



## Growth and yield for scots pine and oriental beech mixed stands in different mixture ratios

Aydın KAHRİMAN <sup>\*1</sup>, İlker ERCANLI <sup>2</sup>, Hakkı YAVUZ <sup>3</sup>

<sup>1</sup>Çankırı Karatekin University, Faculty of Forestry, 18200, Çankırı, Turkey

<sup>2</sup>Artvin Çoruh University, Faculty of Forestry, 08000, Artvin, Turkey

<sup>3</sup>Karadeniz Technical University, Faculty of Forestry, 61080, Trabzon, Turkey

### Abstract

Mixed forest ecosystems are important to human life. In general, there are many positive aspects of mixed stands compared to pure stands biologically and ecologically. In forestry, the importance of mixed stands has increased in recent decades due to the potential benefits which can be gained, such as increased production, greater diversity, improved nutrient cycling or reduced risk of biotic and abiotic damage. Scots pine (*Pinus sylvestris* L.) and Oriental beech (*Fagus orientalis* Lipsky) are two of the most important tree species in Turkey. Mixed Oriental beech and Scots pine stands with different forest structures and biodiversity are widespread in Black Sea Region, Turkey. The management of mixed stands of these species is of increasing importance to foresters in Turkey, and a crucial factor is knowledge of the growth and yield relationship for the sound management of these stands.

This study aimed to determination of the growth and yield relationship for Scots pine and Oriental beech mixed stands in different mixture ratios in Black Sea Region. The data were obtained from 162 temporary sample plots with ranging stand ages, site index, density and mixture percentages. The diameter at breast height of all trees, height and age of a sufficient number of trees for each sample plots were measured and the average age, site index, density and mixture percentage were estimated by these data. The sample plots have 31-150 years for Scots pine and 33-117 years for Oriental beech of stand age range, 16.2-34.9 m Scots pine and 14.7-32.3 m for Oriental beech of site index range, 0.10-0.76 of Scots pine mixture ratio range, 2.9-10.0 of stand density range.

With the generated equation systems, stand age, site index, density and mixture ratio of the four such as age, site index, density and mixture percentage main factors in Oriental beech - Scots pine mixed stands, including the effects on the stands were determined numerically. Volume of main stand and mean annual volume growth show irregular depending on the mixture ratio for the same average age, site index, density and mixture percentage. The number of Oriental beech trees are increasing, while number of Scots pine trees and total number of trees are decreasing depending on the mixture ratio for the same average age, site index, density and mixture percentage. Average height for both species is increasing when mixture ratio is increased to 0.4 to 0.8 for the same average age, site index, density and mixture percentage. The results were in arrangement with the acknowledged growth rules.

**Key words:** mixed stands, yield, mixture percentage, oriental beech, scots pine, black sea region in Turkey

### 1. Introduction

For the last about 35 years the growth and yield of monocultures vs. mixed-species forests has been the subject of studies by forest managers and ecologists. In the last few years, mixed stands dynamics returned into the focus of forest science (Forrester et al., 2006; Pretzsch et al., 2013). In forestry, the importance of mixed stands has increased in recent decades due to the potential benefits which can be gained, such as increased production, greater diversity, improved nutrient cycling or reduced risk of biotic and abiotic damage (Cannell et al., 1992; Man and Lieffers, 1999; Río M., and Sterba, 2009).

Mixed stand definition is as follows; forests including a second tree species with a basal area of at least 10 per cent, in addition to the most abundant species, were defined as mixed forests (Bravo-Oviedo et al., 2014). The advantages of mixed stands are as follows: are more resistant to biotic and abiotic damage, show a maximum total volume production that does not decrease with stand density approaching the maximum but remains constant (Pretzsch, 2002), are more stable due to their sub-dominant and co-dominant trees (Pretzsch, 2002), are able to compensate for impacts on the stand density (windthrow, heavy thinnings) much better than pure stands through an accelerated increment of the residual stand (Pretzsch, 2002), provide a wider range of size classes and timber products, contribute to a greater diversity and therefore provide more habitats, are more

\* Corresponding author / Haberleşmeden sorumlu yazar: Tel.: +904662151035; Fax.: +904662151034; E-mail: kaydin61@hotmail.com

appealing to visitors (Jensen, 2000), help to reduce risks in the case of climate change. In addition, mixed stands reduce the risk of insect and disease outbreaks, support a more diverse habitat for flora and fauna, and are considered to have more visual appeal to the general public than monocultures (Steinbeck and Kuers, 1996).

The mixture percentage and the mixture percentage of the essential items such as volume, basal area varies by country. In order to speak of mixed stands, the species mixture must be represented in a certain mixture percentage. Although there is no value has been adopted as a general on this mixture percentage in the world, a species participate in mixture in different proportions is sufficient. The mixture percentage limits as basal area ratio are taken as 30% in Switzerland, as 10% in Germany, as 10% in Central America and as 25% Southeast Europe (Linden and Agestam, 2003). In Central Europe the limit is usually 10% of either basal area or volume (Burkhart and Tham, 1992). According to the forest management regulations in Turkey, 10% mixture percentage by volume is sufficient to be considered as a mixed stand (General Directorate of Forestry, 2008).

Mixtures of conifers and broadleaves are developing on many sites in upland forests and are favoured by current policies designed to diversify conifer plantations. The mixed stands of Oriental beech and Scotch pine have many biologically and ecologically positive features compared to pure Oriental beech and Scotch pine stands. These mixed stands provide proper conditions for the production of higher-quality, longer, and more well-formed stems; enable an increase in harvest due to having different species; provide mull humus soil composition by accelerating decomposition of soil litter; supply an optimal utilization of soil potential and habitat via different root systems; and are more resistant to wind, snow, and ice damage owing to their diversity, structure, and species combinations (Atay, 1990; Duchiron, 2000).

Oriental beech (*Fagus orientalis Lipsky*) and Scots pine (*Pinus sylvestris L.*) are two of the most economically and ecologically important forest tree species for Turkey (Ertekin et al., 2015), with a wide range of commercial uses. Oriental beech grows naturally in Turkey and is located in the Black Sea, Marmara, Aegean, and East Mediterranean regions, as well as in many other regions of the world (Davis 1982; Ertekin et al., 2015). Oriental beech forests in Turkey cover 1,899,929 ha and compose nearly 8.5 % of the country's total forest area (General Directorate of Forestry, 2015). Scots pine grows in Turkey (38°34' N to 41°48' N and 28°00' E to 43°05' E), from Eskişehir in the west to the country's border in the east, occupying the northern part of the country (Anşın and Özkan, 2006). Scots pine occupies about 1,518,929 ha (6.8 %) in Turkey, growing mainly in the Black Sea coastal mountains (General Directorate of Forestry, 2015). Scots pine grows from sea level up to 2700 m (mainly 1000–2500 m) in Turkey.

The mixtures of these tree species, resulting in diverse forest structure and biodiversity, are widespread in the north of Turkey. Based on a 2015 inventory by the General Directorate of Forestry, the total forest area of Turkey is 22,342,935 ha, of which 8,394,788 ha (38.0%) is mixed stands and 4,367,251 ha (52.02%) of the mixed stand is coniferous and deciduous mixed stand, of which 32,927 ha (1.40%) is mixed stand of Oriental beech and Scotch pine (General Directorate of Forestry, 2015).

Early studies about mixed stands of Oriental beech and Scotch pine, which are a mix of coniferous and deciduous trees and intolerant and tolerant trees, were carried out in Germany from Bonnemann (1939) (Pretzsch, 2009). In this study by Bonnemann (1939), it is stated that the number of stems per hectare for Beech is much greater in comparison with pine and that pine trees are taller at every age in comparison with beech. Whereas beech falls behind in growing in height during its youth, it later reaches pine and stays in the upper layer. Mean diameter of beech is thinner in comparison with pine; however, this difference decreases with increasing age. It was determined that the basal area of beeches is equal to those of pines at the age of 140 – 150. In addition, the total volume efficiency of Pine-Beech stand per hectare is greater in comparison with that of pure Scots Pine stand. Weck (1955) determined that the total stand volume of pine-beech mixed stand is greater in comparison with those of pure pine and beech stands. Wiedemann (1949) determined that the increment is greater in equal age Scots Pine – Beech mixed stands both during the youth and the old periods in comparison with pure stands. In addition, Erteld and Hengst (1966) have determined that the mean volume increment for old pure beech stands is greater in comparison with those of pine-beech mixed stands (Firat, 1972).

In recent years, studies about the planning of mixed stands have become popular, resulting in an increasing trend in these studies worldwide. Changes in silvicultural planning approaches from pure stands to mixed stands increase the need for growth models to determine the effects of silvicultural activities applied in mixed stands. The management of mixed stands of these species is increasingly important for foresters in Turkey. A crucial factor for the sound management of these stands is knowledge of the growth at the individual tree level of each different species. The objective of this study is to develop a site conversion equation for mixed stands of Scots pine and Oriental beech in the Black Sea Region in the north of Turkey.

This study aimed to determination of the growth and yield relationship for Scots pine and Oriental beech mixed stands in different mixture ratios in Black Sea Region.

## 2. Materials and methods

The study area is in the Black Sea Region, the North of Turkey. The study area covers the Forest Districts of Zonguldak, Kastamonu, Sinop, Ankara and Amasya. This study area ranges in latitude (North) from 40°15'28" to 41°46'15" and in longitude (East) from 32°28'02" to 37°32'56" (Figure 1). These sampled mixed stands were naturally regenerated and uniformly stocked stands (55-97% tree layer cover), without any evidence of historical damage such as fire or storms. Located between 750 m and 1750 m altitude, the study area is characterized geomorphological by high mountainous land, with moderate steep slopes ranging between 5% and 60% (30 % of the whole area). The mean annual temperature is between -5.8 C° and 14.6 C°, and minimum and maximum temperatures are -8.4 C° and 22.67 C°, respectively. The climatic regime is of typical Black Sea climate characterized by a mild winter, a cool summer and relatively homogeneous precipitation as high as 1000 and 1250 mm.

In this study, the data were obtained from 162 temporary sample plots with ranging stand age, site index, density and mixture percentage in mixed stands Scots pine (*Pinus sylvestris* L.) and Oriental beech (*Fagus orientalis* Lipsky). The 162 regional-level sample plots obtained by Kahrیمان (2011) were used in this study. These studied beech/pine mixed stands were selected to have uniform stratification when both two species have been in the upper stratum, such that there are site trees of both species in the plot. The size of circular plots ranged from 600 to 1200 m<sup>2</sup>, depending on stand density in order to achieve a minimum of 30-40 trees per these species in sample plots. Within each plot, tree species and the diameter at breast height (d.b.h.) of trees ≥ 6 cm were recorded in the inventory. The diameters at breast height, stump diameter, total height, crown height, crown diameter, age, diameter increment and spatial coordinate were measured in trees of sample plots. In each plot altitude, aspect and slope were also measured.



Figure 1. Map showing the locations of the regional administrative forest districts in which mixed Scots pine-Oriental beech were studied in the north of Turkey.

Descriptive statistics including mean, minimum, maximum and standard deviation of the plot characteristics such as stand age, site index, quadratic mean diameter, mean height weighted by basal area, stand basal area, stand volume, number of trees per hectare, stand density and mixture percentage are listed below (Table 2).

Table 1. Minimum, maximum, mean and standard deviation (SD) of main characteristics of the study material.

Species	Variable	Mean	Min.	Max.	SD
Scots pine	A (year)	84.2	31.4	150.1	27.4
	SI (m)	25.9	16.2	34.9	4.3
	$\bar{d}_g$ (cm)	34.9	16.6	51.1	8.3
	$\bar{h}_g$ (m)	22.5	8.2	35.1	6.7
	G (m <sup>2</sup> /ha)	20.1	6.1	42.9	8.3
	V (m <sup>3</sup> /ha)	218.0	32.0	535.3	120.6
	N (number/ha)	230.8	62.5	600.0	117.9
Oriental beech	A (year)	71.9	33.2	117.0	19.5
	SI (m)	24.3	14.7	32.3	3.6
	$\bar{d}_g$ (cm)	20.1	8.8	39.7	5.7
	$\bar{h}_g$ (m)	18.3	9.2	28.7	5.0
	G (m <sup>2</sup> /ha)	13.0	1.8	33.6	6.2
	V (m <sup>3</sup> /ha)	116.8	6.5	335.8	76.7
	N (number/ha)	436.7	60.0	1025.0	200.0
Sum	G (m <sup>2</sup> /ha)	33.1	12.7	55.9	10.9
	V (m <sup>3</sup> /ha)	334.8	52.3	717.9	169.0
	N (number/ha)	667.6	180.0	1520.0	241.8
	RD	6.5	2.9	10.0	1.8
	P <sub>Pine</sub>	0.61	0.24	0.90	0.14

A age, SI site index,  $\bar{d}_g$  quadratic mean diameter,  $\bar{h}_g$  mean height weighted by basal area, G basal area, V stand volume, N number of stems per hectare, RD relative density (stand density according to Curtis, 1982), P<sub>Pine</sub> mixture percentage according to Scots pine tree.

When analyzing the effect of interspecific interaction on stand growth in mixed species forests, the definition of species proportions plays an important role. Mixture is expressed as percentage and shown with the numbers between 10 %- 90 %. Species proportions can be defined in many different ways, by crown cover, stem number, basal area, volume, or biomass; depending on the objective of the study (Bravo-Oviedo et al., 2014). For a given mixed stand, the

species proportion may differ considerably depending on species proportion definition, and, consequently, different net effects on stand growth were reported (Pretzsch, 2009). The most common way to define species proportion is by basal area (Légaré et al., 2004; Perot and Picard, 2012; Groot et al., 2014). Besides, participation rate of the species to the canopy cover is based on the determination of the mixture ratio on the aerial photo.

Although mixture percentage can be identified by taking into account of various stand parameters such as the number of trees, basal area and volume, it can be determined generally depending on basal area values of species. Because basal area can be determined easily and is in relation with a high level of stand volume. The mixture percentage is calculated depending on basal area of pine – beech species in this study. Mixture percentage of mixed stands of Oriental beech and Scotch pine is calculated by the proportion of the total basal area of Scots pine trees in stands to the total basal area of the stands.

$$P_{Pine} = \frac{G_{Pine}}{G_{Total}}$$

where  $P_{Pine}$  is mixture percentage of Scots pine in stands,  $G_{Pine}$  is total basal area of Scots pine trees in stands and  $G_{Total}$  is the total basal area of the stands.

The data evaluated within the scope of this study were obtained from the study by Kahrیمان (2011). In the study carried out by Kahrیمان (2011), stand models related to Scots pine-Oriental beech mixed stands was developed as density-variable yield tables. The mean diameter ( $\bar{d}_g$ ), mean height ( $\bar{h}_g$ ), tree density (N), basal area (G) and stand volume (V) of main stand were calculated in density-variable yield tables as functions of stand age (A), site index (SI), stand density (RD) and mixture ratio ( $P_{Pine}$ ) via regression equations. Afterwards, the change in the main and removed stand elements of the density-variable yield tables as well as the other elements of the yield table were calculated for both Scots pine and Oriental beech separately on the basis of stands. Growth values of Scots pine-Oriental beech mixed stands were put forth in this study for different mixture percentages using the data acquired from the study carried out by Kahrیمان (2011).

### 3. Results

162 samples were taken in this study that will reflect the variety in age, site index, stand densities and mixture percentages. The distributions of sample areas according to age, site index, stand density and mixture percentages was given in Figure 2.

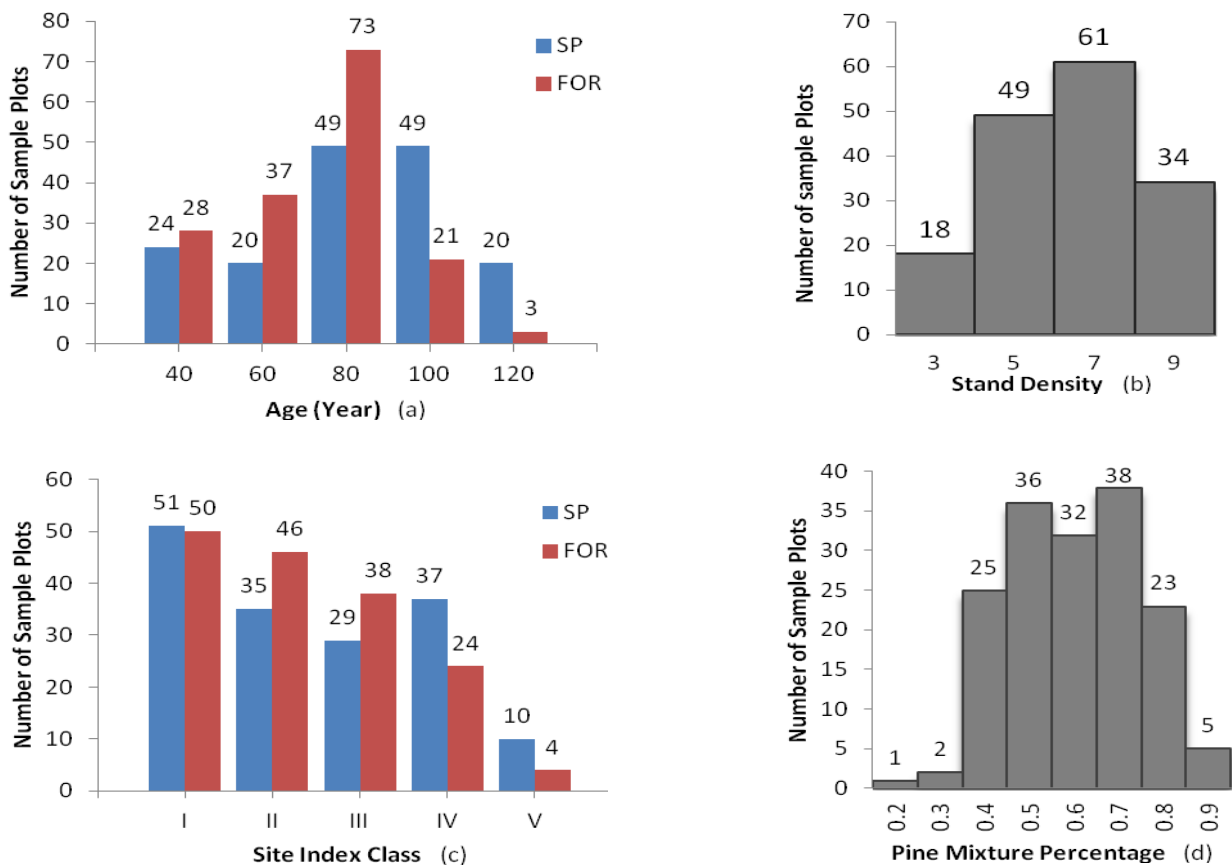

Figure 2. Distribution of sample plots by age (a), stand density (b), site index class (c) and mixture percentage (d) (SP: Scots pine, FOR: Oriental beech)

The sample plots distribution for Scots pine according to the age classes of 40, 60, 80, 100 and 120 were respectively 24, 20, 49, 49 and 20 whereas for Oriental Beech it was 28, 37, 73, 21 and 3 (Figure 2a). 18 of the sample plots are in the stand density of 3, 49 are in the stand density of 5, 61 are in the stand density of 7 and 34 are in the stand density of 9 (Figure 2b). The distribution of sample plots according to site index for Scots pine from good site index to bad site index was 51, 35, 29, 37 and 10 respectively whereas for Oriental Beech it was 50 46, 38, 24 and 4 (Figure 2c). When the distributions of sample plots according to the mixture percentages of Scots pine are examined, it was observed that of the 162 sample sites, the mixture percentages were 0.2, 0.3, 0.4, 0.5, 0.6, 0.7, 0.8 for 1, 2, 25, 36, 32, 38 and 28 respectively (Figure 2d).

The change of total stand volume based on mixture percentage for the same age, site index class and stand density were given in Table 2 and Figure 3. Total stand volume shows an irregularity based on the mixture percentage for the same age, site index class and stand density (Table 2, Figure 3). Namely; the total yield shows a general decrease in stands that are younger than 40 years for the same stand density and site index from a mixture percentage of 0.8 to 0.6 and 0.4. Total stand volume increases towards 0.6, 0.4, 0.8 mixture percentage for the low densities of I. SI stands aged 40-60 and towards 0.4, 0.6, 0.8 for the stands in the II. III. IV. and V. SI and the moderate and high densities of the I. SI stands. Total stand volume increase is observed in the I. SI and II. SI low density stands at the age of 60-80 towards a mixture percentage of 0.6, 0.4, 0.8 respectively; whereas the mean stand volume increases towards the 0.4, 0.6, 0.8 mixture percentage respectively for III., IV., V. SI and the moderate and high density stands of the II. SI. An increase in the total stand volume is observed towards 0.6, 0.4, 0.8 mixture percentages respectively for the I., II. SI of stands older than 80 and the lower stand density of the III. SI; whereas an increase in the total stand density is observed towards 0.4, 0.6, 0.8 mixture percentages respectively for the IV., V. SI and the moderate and higher density stands of the III. SI.

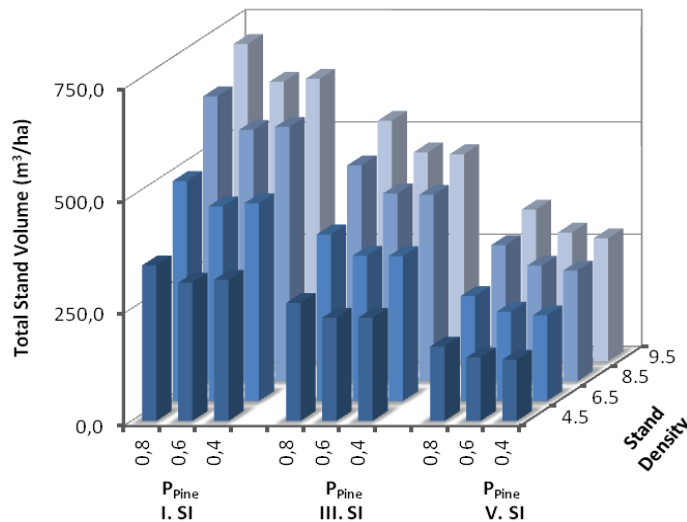

Figure 1. The change of Total Stand Volume according to index site class, stand density and mixture percentage (stand age=80 year)

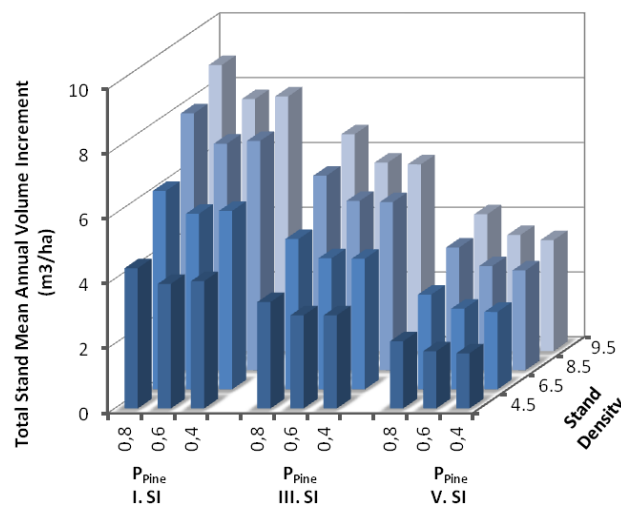

Figure 2. The change of Mean Annual Volume Increment for Total Stand according to site index class, stand density and mixture percentage (Stand age=80 year)



Whereas total stand volume is 634.1, 566.3 and 559.4 m<sup>3</sup>/ha for the 8.5 stand density I. SI stands aged 80 with respective mixture percentages of 0.8, 0.4 and 0.6 respectively; it is 480.5, 415.0 and 418.0 m<sup>3</sup>/ha for the III. SI and 303.0, 246.4 and 257.3 m<sup>3</sup>/ha for the V. SI. Whereas total stand volume is 229.7, 193.6 and 185.9 m<sup>3</sup>/ha for the 8.5 stand density III. SI stands aged 40 with respective mixture percentages of 0.8, 0.6 and 0.4; it is 480.5, 418.0 and 415.0 m<sup>3</sup>/ha for 80 year stands with respective mixture percentages of 0.8, 0.6 and 0.4 and 554.4, 485.0 and 483.8 m<sup>3</sup>/ha for 120 year old stands with respective mixture percentages of 0.8, 0.6 and 0.4 (Table 2).

Table 2. The change of Total Stand Volume and Mean Annual Volume Increment for Total Stand (m<sup>3</sup>/ha) according to stand ages, site index, density and mixture percentage

Total Stand Volume						Mean Annual Volume Increment for Total Stand					
SD	P <sub>Pine</sub>	A	I. SI	III. SI	V. SI	SD	P <sub>Pine</sub>	A	I. SI	III. SI	V. SI
4.5	0.4	40	140.9	102.3	59.6	4.5	0.4	40	3.52	2.56	1.49
4.5	0.4	80	314.3	229.9	136.1	4.5	0.4	80	3.93	2.87	1.70
4.5	0.4	120	366.5	268.4	159.2	4.5	0.4	120	3.05	2.24	1.33
4.5	0.6	40	142.3	105.2	63.3	4.5	0.6	40	3.56	2.63	1.58
4.5	0.6	80	307.7	229.8	141.2	4.5	0.6	80	3.85	2.87	1.77
4.5	0.6	120	356.8	266.9	164.6	4.5	0.6	120	2.97	2.22	1.37
4.5	0.8	40	165.1	123.6	76.2	4.5	0.8	40	4.13	3.09	1.90
4.5	0.8	80	346.4	262.6	165.7	4.5	0.8	80	4.33	3.28	2.07
4.5	0.8	120	399.5	303.5	192.3	4.5	0.8	120	3.33	2.53	1.60
6.5	0.4	40	198.7	144.5	84.2	6.5	0.4	40	4.97	3.61	2.11
6.5	0.4	80	440.7	322.6	191.2	6.5	0.4	80	5.51	4.03	2.39
6.5	0.4	120	513.4	376.1	223.4	6.5	0.4	120	4.28	3.13	1.86
6.5	0.6	40	202.3	149.7	90.2	6.5	0.6	40	5.06	3.74	2.25
6.5	0.6	80	433.4	323.7	199.0	6.5	0.6	80	5.42	4.05	2.49
6.5	0.6	120	501.9	375.5	231.6	6.5	0.6	120	4.18	3.13	1.93
6.5	0.8	40	236.1	176.9	109.1	6.5	0.8	40	5.90	4.42	2.73
6.5	0.8	80	489.8	371.1	233.9	6.5	0.8	80	6.12	4.64	2.92
6.5	0.8	120	563.9	428.2	271.0	6.5	0.8	120	4.70	3.57	2.26
8.5	0.4	40	255.5	185.9	108.5	8.5	0.4	40	6.39	4.65	2.71
8.5	0.4	80	566.3	415.0	246.4	8.5	0.4	80	7.08	5.19	3.08
8.5	0.4	120	659.7	483.8	288.0	8.5	0.4	120	5.50	4.03	2.40
8.5	0.6	40	261.6	193.6	116.8	8.5	0.6	40	6.54	4.84	2.92
8.5	0.6	80	559.4	418.0	257.3	8.5	0.6	80	6.99	5.23	3.22
8.5	0.6	120	647.8	485.0	299.5	8.5	0.6	120	5.40	4.04	2.50
8.5	0.8	40	306.5	229.7	141.8	8.5	0.8	40	7.66	5.74	3.54
8.5	0.8	80	634.1	480.5	303.0	8.5	0.8	80	7.93	6.01	3.79
8.5	0.8	120	730.1	554.4	351.1	8.5	0.8	120	6.08	4.62	2.93
9.5	0.4	40	283.6	206.4	120.6	9.5	0.4	40	7.09	5.16	3.01
9.5	0.4	80	629.0	461.1	274.1	9.5	0.4	80	7.86	5.76	3.43
9.5	0.4	120	732.8	537.8	320.5	9.5	0.4	120	6.11	4.48	2.67
9.5	0.6	40	291.0	215.4	130.0	9.5	0.6	40	7.27	5.39	3.25
9.5	0.6	80	622.5	465.4	286.7	9.5	0.6	80	7.78	5.82	3.58
9.5	0.6	120	721.1	540.0	333.9	9.5	0.6	120	6.01	4.50	2.78
9.5	0.8	40	341.6	256.0	158.0	9.5	0.8	40	8.54	6.40	3.95
9.5	0.8	80	706.6	535.5	337.8	9.5	0.8	80	8.83	6.69	4.22
9.5	0.8	120	813.7	618.2	391.7	9.5	0.8	120	6.78	5.15	3.26

A age, SI site index, RD relative density (stand density according to Curtis, 1982), P<sub>Pine</sub> mixture percentage according to Scots pine tree.

Mean annual volume increment for total stand is irregular based on the mixture percentage of the same age, site index and stand density (Table 2, Figure 4). The mean annual volume increment values for stand in the 8.5 stand density aged 80 in the I. SI are 7.93, 7.08 and 6.99 m<sup>3</sup>/ha for respective mixture percentages of 0.8, 0.4 and 0.6; whereas the values are 6.01, 5.19 and 5.23 m<sup>3</sup>/ha for the III. SI and 3.79, 3.08 and 3.22 m<sup>3</sup>/ha for V. SI. Whereas the mean annual volume increment values for total stand are 5.74, 4.84 and 4.65 m<sup>3</sup>/ha respectively for III. SI 8.5 stand density stands aged 40 with respective mixture percentages of 0.8, 0.6 and 0.4; for those aged 80 with mixture percentage values of 0.8, 0.6 and 0.4 they are 6.01, 5.23 and 5.19 m<sup>3</sup>/ha respectively and 4.62, 4.04 and 4.03 m<sup>3</sup>/ha for mixture percentage values of 0.8, 0.6 and 0.4 aged 120 (Table 2).

Volume and volume increments for the same stand density and site index have the highest values for the 0.8 mixture percentage in the density-variable yield tables for Scots pine-Oriental beech mixed stands. Whereas volume and volume increments decrease from a mixture percentage of 0.8 to 0.6 and 0.4 for young stands, it generally decreases

from 0.8 mixture percentage to 0.4 and 0.6 for the fine site indexes of old stands. The total volume of the stand increases in good site index in which the growing energy of the beech trees with wolf tree feature is given to stem growth instead of branching. This is observed in old stands with good site index. Mixture percentage of 0.6 in stands where Oriental beech individuals are generally overgrown and 0.4 mixture percentage in stands with shapelier stems which are not overgrown are ranked second. The fact that volume is greatest in the 0.8 mixture percentage can be explained by the facts that the Scots pine which is a light tree has higher volume since it is located at the upper layer and has greater diameter. The fact that volume is smaller when the mixture percentage is % 40-60 can be explained by the facts that the diameter and heights of Scots pine individuals are % 80 lower in comparison with the mixture and that the number of beech per unit area is smaller. That is, the diameters of Scots pine trees decrease depending on their diameter and height when the ratio of both species in the stand is equal while the total volume decreases since the number of beech trees is smaller. It can be concluded that the change in the volume and volume increase depending on the mixture percentage is natural for the Scots pine and Oriental beech mixed stands. The fact that volume and volume increase values are greater in stands with greater ratio of Scots pine in Scots pine-Oriental beech mixed stands shows that the volume and volume increase values are greater as we move towards pure Scots pine stands. Çalışkan (1989) has determined that the stand volume and basal area is greater in stands with greater number of Scots pines in the Karabük Büyükdüz research forest with Scots pine, fir and beech mixed stands.

The change of stand volume with mixture percentage is given in Figure 5. When Figure 5 is examined, it is observed that there is no data related negativity that might cause the low values of the observed actual volume values in the sample areas for the mixture percentage.

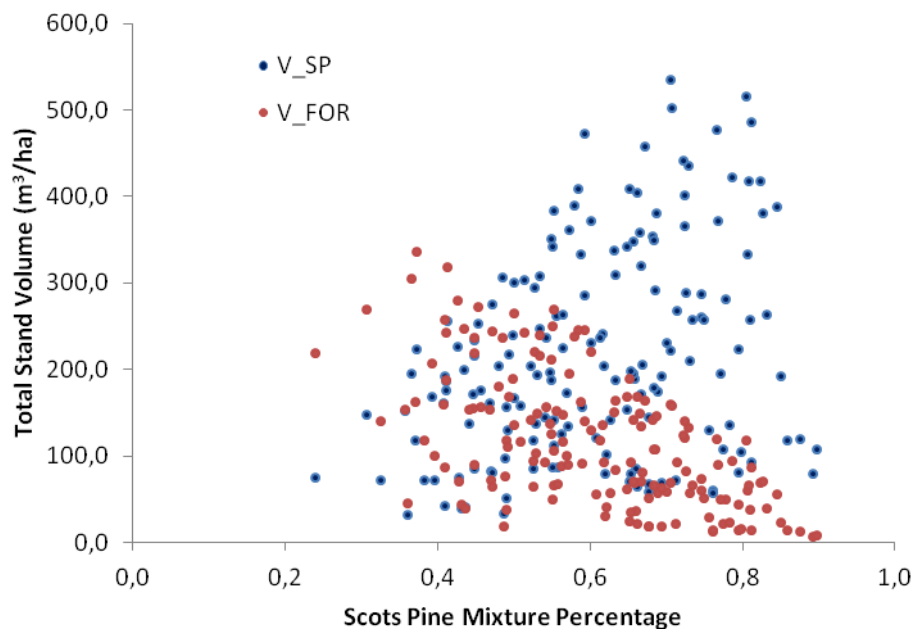

Figure 5. The change of Scots pine and Oriental beech Stand Volume according to Scots pine mixture percentage

The quadratic mean diameter (Figure 6a), mean height weighted by basal area (Figure 6b), total stand volume (Figure 7a), mean annual volume increment for total stand (Figure 7b), tree density (Figure 8a) and mean annual increment (Figure 8b) values related with the density-variable yield tables prepared for Scots pine-Oriental beech mixed stands for both species were compared at a stand density of 8.5 and the site indexes in all mixture percentages.

The quadratic mean diameter and mean height weighted by basal area values are greater for the Scots pine in comparison with the Oriental beech for stand density of 8.5 and III. SI (Figure 6a and 6b). Whereas Scots pine mean height increases as we move from mixture percentage of 0.4 to 0.6 and 0.8 until the age of 80, it increases from mixture percentage of 0.8 to 0.6 and 0.4 for ages above 80. Oriental beech quadratic mean diameter increases as we move from mixture percentage of 0.8 to 0.6 and 0.4 (Figure 6a). Mean height weighed by basal area values increase from mixture percentage of 0.8 to 0.6 and 0.4 for both species (Figure 6b). Total stand volume and mean annual volume increment for total stand values increase from mixture percentage of 0.4 to 0.6 and 0.8 for Scots pine, whereas for Oriental beech it increases from a mixture percentage of 0.8 to 0.6 and 0.4 (Figure 7a and 7b). Whereas volume and increment values for the 0.4 mixture percentage are greater in Scots pine until the age of 55, after the age of 55 these values are greater for Oriental beech. Whereas mean annual increment increases for Scots pine from a mixture percentage of 0.4 to 0.6 and 0.8, it increases from a mixture percentage of 0.8 to 0.6 and 0.4 for Oriental beech (Figure 8b). Mean annual increment

at the mixture percentage of 0.4 is greater in Oriental beech in comparison with Scots pine. Whereas tree density increases for Scots pine from a mixture percentage of 0.4 to 0.6 and 0.8, it increases from a mixture percentage of 0.8 to 0.6 and 0.4 for Oriental beech (Figure 8a). The total tree density in the stand is greatest for the mixture percentage of 0.4, whereas it is smaller for the mixture percentage values of 0.6 and 0.8.

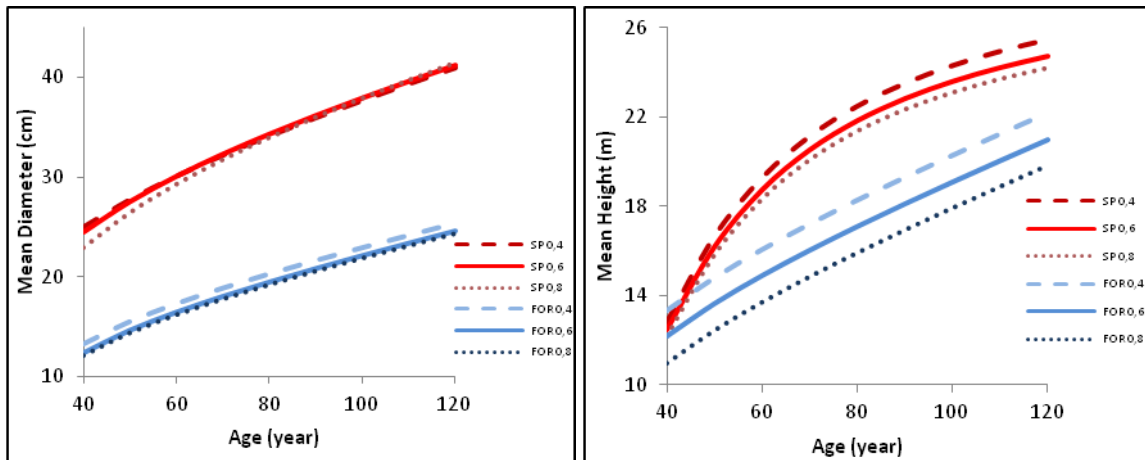

Figure 6. The compare of mean diameter (6a) and mean height (6b) based on mixture percentage for both species at a stand density of 8.5 and the III. SI

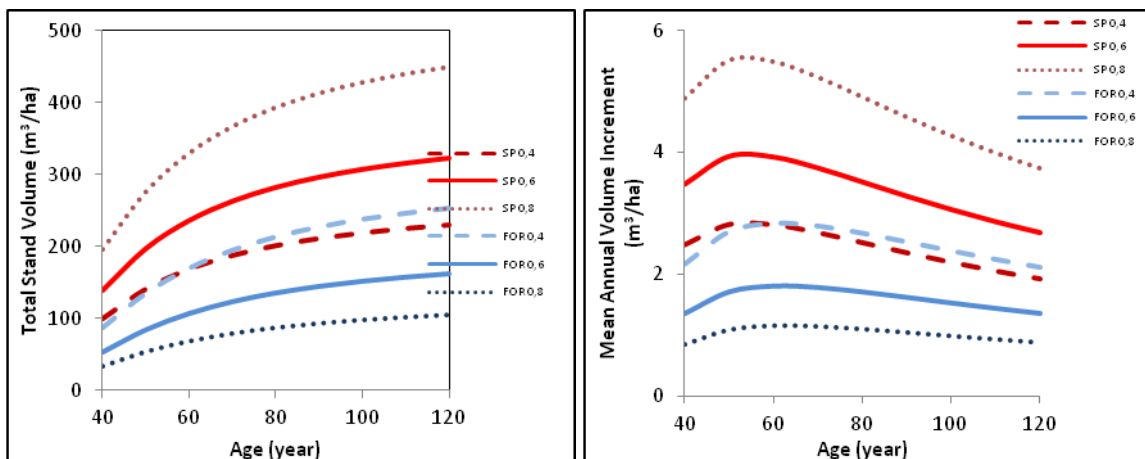

Figure 7. The compare of total stand volume (7a) and mean annual volume increment (7b) based on mixture percentage for both species at a stand density of 8.5 and the III. SI

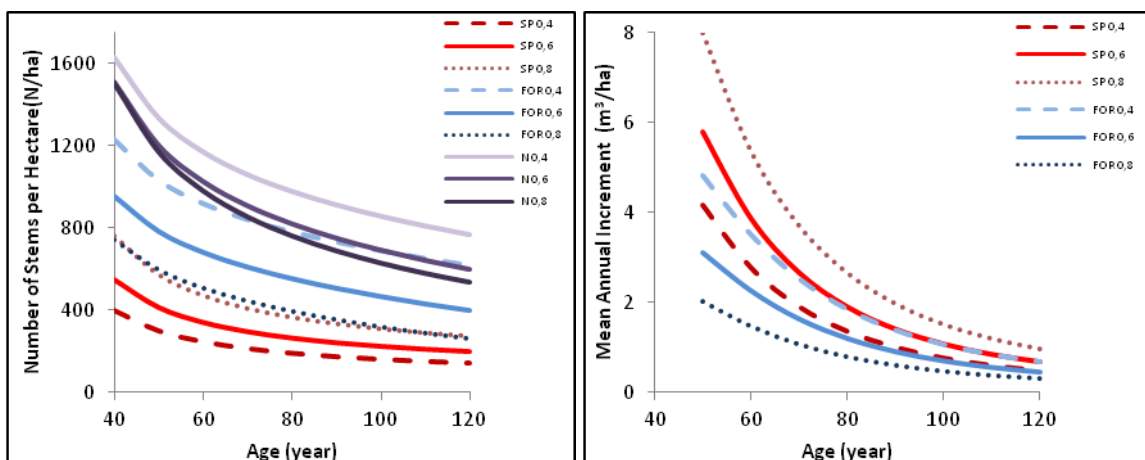

Figure 8. The compare of tree density (8a) and mean annual increment (8b) based on mixture percentage for both species at a stand density of 8.5 and the III. SI

The density-variable yield tables prepared as part of our study were compared with the normal yield tables prepared by Alemdağ (1967) and Batu (1971) for pure Scots pine and by Carus (1998) for pure Oriental Beech. The normal stand density value of Scots pine-Oriental beech mixed stands was taken as 8.5 considering the density of the areas where measurements were carried out. The comparison of yield tables were carried out using the volume and volume increment values at the stand density of 8.5 which is considered as normal in this study. In addition, values in the yield tables for stands of tree species grown under the best conditions, meaning the values for the stands in the first site index for all species were compared in order to get better results. The total stand volume, mean annual increment and mean increment values for total stand for Scots pine and Oriental beech as well as the Scots pine-Oriental beech stands in this study with good site index and normal density are given in Figure 9a, 9b and 10.

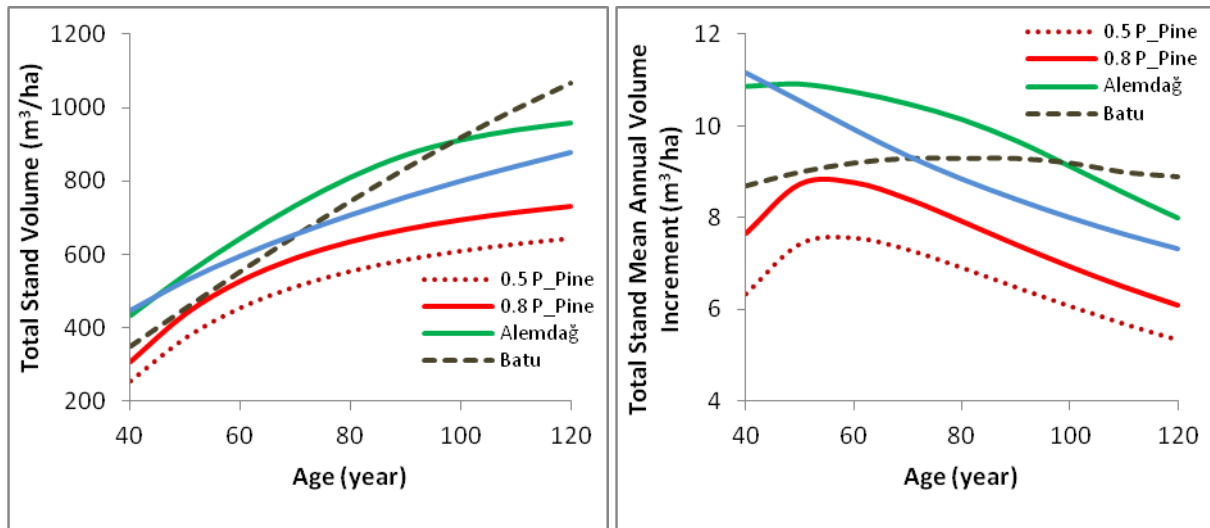

Figure 9. The change of Total Stand Volume (9a) and Total Stand Mean Annual Volume Increment (9b) of SP-FOR, Scots pine (Alemdağ, 1967 and Batu, 1971) stands at normal stand density value and good site index

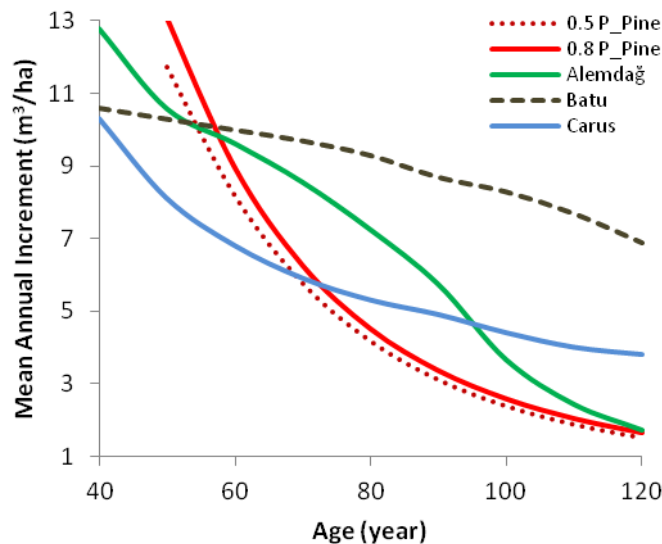

Figure 10. The change of Mean Annual Increment of SP-FOR, Scots pine (Alemdağ, 1967 and Batu, 1971) and Oriental beech (Carus, 1998) stands at normal stand density value and good site index

Total stand volume and mean annual volume increment values are ranked first for Oriental beech (Carus, 1988) until the age of 45, for Scots pine (Alemdağ, 1967) between the ages of 45-100 and for Scots pine (Batu, 1971) after 100 years of age (Figure 9a and 9b). Total stand volumes at 100 years are ranked as; 917.4 m³/ha Scots pine (Batu, 1971), 912.2 m³/ha Scots pine (Alemdağ, 1967), 800.0 m³/ha Oriental beech (Carus, 1988), 693.4 m³/ha SP-FOR stands (0.8 mixture percentage) and 607.5 m³/ha SP-FOR stands (0.5 mixture percentage). Mean annual volume increment for total stand at 100 years of age are ranked as; 9.20 m³/ha Scots pine (Batu, 1971), 9.12 m³/ha Scots pine (Alemdağ, 1967), 8.0 m³/ha Oriental beech (Carus, 1988), 6.93 m³/ha SP-FOR (0.8 mixture percentage) and 6.07 m³/ha SP-FOR stands (0.5 mixture percentage).

Mean annual increment is highest until the age of 60 in SP-FOR stands (0.8 mixture percentage stands) and in Scots pine stands (Batu, 1971) after the age of 60 (Figure 10). Stands at SP-FOR stands (0.8 mixture percentage) have higher mean annual increment than Scots pine stands (Batu, 1971), Scots pine (Alemdağ) and Oriental beech (Carus, 1988) until the age of 60 and higher than Oriental Beech (Carus, 1988) between 60-75 years of age. Stands at SP-FOR (0.8 mixture percentage) have higher mean annual increment than Scots pine (Batu, 1971), Scots pine (Alemdağ, 1967) and Oriental beech (Carus, 1988) until the age of 55 and higher than Oriental Beech (Carus, 1988) between the ages of 55-70. Mean annual increment at the age of 100 is ranked as; 8.30 m<sup>3</sup>/ha Scots pine (Batu, 1971), 4.40 m<sup>3</sup>/ha Oriental beech (Carus, 1988), 3.66 m<sup>3</sup>/ha Scots pine (Alemdağ, 1967), 2.57 m<sup>3</sup>/ha SP-FOR (0.8 mixture percentage) and 2.40 m<sup>3</sup>/ha SP-FOR (0.5 mixture percentage).

#### 4. Conclusions and discussion

Quadratic mean diameter in Scots pine decreases from 0.8 mixture percentage to 0.4 and 0.6 for I. SI at the same age and lower stand densities, whereas it decreases from 0.8 mixture percentage to 0.6 and 0.4 in moderate and high stand densities; from 0.4 mixture percentage to 0.6 and 0.8 in stands with low stand density in II. SI and from 0.8 mixture percentage to 0.6 and 0.4 in moderate and high stand densities. Quadratic mean diameter generally decreases from 0.8 mixture percentage to 0.4 and 0.6 for stands younger than 100 years of age at all stand densities in III., IV and V. SI and at all stand densities, whereas it decreases from 0.4 mixture percentage to 0.6 and 0.8 for stands older than 100 at all stand densities. Whereas quadratic mean diameter for Oriental beech, decreases from 0.6 mixture percentage to 0.4 and 0.8 in the same site index and same age as we move to lower stand densities and it decreases from 0.6 mixture percentage to 0.8 and 0.4 at moderate and high stand densities.

Total stand volume and increment is irregular for the same age, site index and stand density depending on the mixture percentage. Total yield and its increment decreases from 0.8 mixture percentage to 0.6 and 0.4 for stands younger than 40 years of age at the same stand density and site index. Total stand volume and its increment of aged 40-60 increases towards 0.6, 0.4, 0.8 mixture percentage for the low stand densities of stands in the I. SI and towards 0.4, 0.6, 0.8 mixture percentage in stands included in II., III., IV. and V. SI with moderate and high stand densities of I. SI. There is an increase in total stand volume of 60-80 years old in the low stand densities I. SI and II. SI stands respectively as we move towards 0.6, 0.4, 0.8 mixture percentage and towards 0.4, 0.6, 0.8 mixture percentage respectively for III., IV., V. SI and the moderate and high density stands of II. SI. There is an increase in total stand volume and increment that are over the age of 80 towards 0.6, 0.4, 0.8 mixture percentage for in the I., II. SI and the low stand densities of stands in the III. SI and towards 0.4, 0.6, 0.8 mixture percentage in stands included in IV. and V. SI with moderate and high stand densities of III. SI. The portion of cumulated removed stand based on mixture percentage increase from 0.8 mixture percentage to 0.4 and 0.6 same age, site index and stand density.

The density variable yield tables prepared as part of this study were compared by the normal yield tables prepared by Alemdağ (1967) and Batu (1971) for Scots pine and by Carus (1998) for pure Oriental beech. It was determined that the total stand volume and mean increment values of SP-FOR mixed stand with 0.8 mixture percentage, I. SI and normal stand density (8.5 stand density) were highest for Oriental beech (Carus, 1988) until the age of 45, for Scots pine (Alemdağ, 1967) during the ages of 45-100 and for Scots pine (Batu, 1971) after the age of 100. It was determined that the mean annual increment was highest in SP-FOR mixed stand with a mixture percentage of 0.8 until the age of 60 and for Scots pine (Batu, 1971) stand after the age of 60.

The volume and volume increment values related with the density variable yield tables prepared for Scots pine-Oriental beech mixed stands were compared for both species at 8.5 stand density and site indexes in all mixture percentages. It was determined that the volume and volume increment values increased from 0.4 mixture percentage to 0.6 and 0.8 for Scots pine and from 0.8 mixture percentage to 0.6 and 0.4 for Oriental beech. It was put forth that the volume and increment values at 0.4 mixture percentage were highest in Scots pine until the age of 55, whereas it was highest for Oriental beech after 55 years of age. It was determined that the mean annual increment value increased from 0.4 mixture percentage to 0.6 and 0.8 for Scots pine and from 0.8 mixture percentage to 0.6 and 0.4 for Oriental beech (Figure 8b).

It will be possible to continue the existence of Scots pine- Oriental beech mixed stands that are economically and biologically important for the Middle and Western Black Sea Regions only via the arrangement of forest management plans that take into consideration the growth relations of these forests as well as their stand structures. Hence, it is important for the development of forest management plans to have knowledge about the growth relations of species in Scots pine-Oriental beech mixed stands. This study will enable the development of growth models required for both management plans and civil culture applications by determining the production potentials related with Scots pine – Oriental beech mixed stands. The ecological, economic and social functions of Scots pine – Oriental beech mixed stands will be used most effectively by determining the growth legalities for both species separately and as a whole.

#### Acknowledgements

This study is a part of a doctorate thesis prepared by Aydın Kahrıman for the Institute of Natural and Applied Science, Karadeniz Technical University, Trabzon, Turkey. This work was supported by the Karadeniz Technical University Project Department, Project No: 2007.113.001.1.

## References

- Alemdağ, Ş., 1967. Türkiye'deki Sarıçam Ormanlarının Kuruluşu, Verim Gücü ve Bu Ormanların İşletilmesinde Takip Edilecek Esaslar, Ormancılık Araştırma Enstitüsü Teknik Bülten No: 20, Ankara.
- Anşin, R. ve Özkan, Z.C., 2006. Tohumlu Bitkiler (Spermatophyta) Odunsu Taksonlar, 3. Baskı, Karadeniz Teknik Üniversitesi, Orman Fakültesi, Genel Yayın No:167, Fakülte Yayın No:19, Trabzon.
- Atay, İ., 1990. Silvikültür II. Silvikültürün Tekniği, İstanbul Üniversitesi, Orman Fakültesi Yayınları, İ.Ü.Yayın No:3599, Fakülte Yayın No:405, İstanbul.
- Batu, F., 1971. Ertraktafeln und Leistung Potential der Kiefer (*Pinus sylvestris* L.) in der Turkei, Doktora Tezi, Freiburg Universitat, Freiburg, 110 p.
- Bravo-Oviedo, A., Pretzsch, H., Ammer, C., Andenmatten, E., Barbati, A., Barreiro, S., ... Zlatanov, T. (2014). European mixed forests: definition and research perspectives. *Forest Systems*, 23(3), 518-533.
- Bonnemann A. 1939. Der gleichaltrige Mischbestand von Kiefer und Buche. *Mitt Forstwirtsch u Forstwiss* 10: (4), 45 pp.
- Burkhardt, H. E., and Tham, A. 1992. Predictions from growth and yield models of the performance of mixed - species stands. In: *The Ecology of Mixed Species Stands of Trees*. M.G.R. Camel et al. (eds). Oxford Blackwell Scientific Publications. London, Edinburgh, Boston, Melbourne, Paris, Berlin, Vienna. pp. 21-34.
- Cannell M.G.R., Malcon D.C., and Robertson P.A. (Eds.), 1992. *The ecology of mixed-species stands of trees*, Blackwell scientific publications, Oxford, 312 p.
- Carus, S., 1998. Aynı Yaşlı Doğu Kayını (*Fagus Orientalis* Lipsky) Ormanlarında Artım ve Büyüme, Doktora Tezi, İstanbul Üniversitesi, Fen Bilimleri Enstitüsü, İstanbul.
- Curtis, R.O. 1982. A simple index of stand density for Douglas-fir. *For. Sci.* 28: 92 – 94.
- Çalışkan, A., 1989, Karabük Büyükdüz Araştırma Ormanında Sarıçam (*Pinus sylvestris* L.)-Göknar (*Abies bornmüleriana* Matff.) –Kayın (*Fagus orientalis* Lipsky.) Karışık Meşcerelerinde Büyüme İlişkileri ve Gerekli Silvikültürel İlişkiler, Doktora Tezi, İstanbul Üniversitesi, Fen Bilimleri Enstitüsü, İstanbul.
- Davis PH 1982. *Flora of Turkey and the East Aegean Islands*. Edinburgh, UK: Edinburgh University Press.
- Duchiron MS 2000. *Strukturierte Mischwälder. Eine Herausforderung für den Waldbau unsere Zeit*. Parey Buchverlag, Berlin.
- Ertekin, M., Kırdar, E., Ayan, S. 2015. The effects of exposure, elevation and tree age on seed characteristics of *Fagus orientalis* Lipsky. *South-east Eur for* 6 (1): 15-23. DOI: <http://dx.doi.org/10.15177/seefor.15-03>
- Erteld, W., Hengst, E., 1966. *Waldtragslehre*. Radebeul. Neumann Verlag, 332 pp.
- Fırat, F., 1972. Orman Hasılat Bilgisi, İ. Ü. Orman Fakültesi Yayın No: 166, 191 s.
- Forrester DI, Bauhus J, Cowie AL, Vanclay JK 2006. Mixed-species plantations of *Eucalyptus* with nitrogen-fixing trees: a review. *Forest Ecology and Management* 233: 211-230. - doi: 10.1016/j.foreco.2006.05.012.
- General Directorate of Forestry 2008. *Criteria and Indicators for Sustainable Forest Management Report for 2008*. Ankara, Turkey: Turkey General Directorate of Forest Publications.
- General Directorate of Forestry 2015. *Forest Resources of Turkey*. Ankara, Turkey: Turkey General Directorate of Forest Publications.
- Groot A, Adhikary S, Sharma M, Luckai N, Bell FW, Larocque GR, 2014. Effect of species composition on the production rate and efficiency of young *Picea glauca*-*Populus tremuloides* forests. *Forest Ecology and Management* 315: 1-11.
- Jensen, F. S., 2000. The effects of information on Danish forest visitors' acceptance of various management actions. *Forestry*: 73, 165-172.
- Kahriman A 2011. Modeling of forest growth for Scots pine and Oriental beech mixed stands in Black Sea Region. PhD, Karadeniz Technical University, Graduate School of Natural and Applied Sciences, Trabzon.
- Légaré S, Paré D, Bergeron Y, 2004. The responses of black spruce growth to an increased proportion of aspen in mixed stands. *Canadian Journal of Forest Research* 34: 405-416.
- Linden, M. ve Agestam, E. 2003, Increment and yield in mixed and monoculture stands of *pinus sylvestris* and *picea abies* on an experiment in southern sweden, *Scand. J. For. Res.* 18: 155-162.
- Man R. and Loeffers V.J. 1999. Are mixtures of aspen and white spruce more productive than single species stands?. *The Forestry Chronicle* 75: 505–513.
- Perot T, Picard N. 2012. Mixture enhances productivity in a two-species forest: evidence from a modeling approach. *Ecological Research* 27: 83-94.
- Pretzsch H. 2002. The elasticity of growth in pure and mixed stands of Norway spruce (*Picea abies* [L.] Karst.) and common beech (*Fagus sylvatica* L.). *Journal of Forest Science*, 49, 11:491–501.
- Pretzsch H. 2009. *Forest dynamics, growth and yield. A review, analysis of the present state, and perspective*. Springer, Berlin, Germany.
- Pretzsch H. 2013. Facilitation and competition in mixed-species forests analysed along an ecological gradient. *Nova Acta Leopoldina* NF 114, 391: 159-174.
- Río M., and Sterba H. 2009. Comparing volume growth in pure and mixed stands of *Pinus sylvestris* and *Quercus pyrenaica*. *Ann. For. Sci.* 66, 502.
- Steinbeck, K., K. Kuers. 1996. Development of pine-hardwood mixtures following clearcutting on two upland sites in the Georgia Piedmont: 10 year results. *South. J. Appl. For.* 20:203-208.
- Weck J. 1955. *Forstliche Zuwachs- und Ertragskunde*. Neumann Verlag, Radebeul, Berlin.
- Wiedemann E. 1949. *Ertragstafeln der wichtigen Holzarten bei verschiedener Durchforstung*. Verlag M & H Schaper, Hannover.

(Received for publication 27 July 2015; The date of publication 15 August 2016)



## Bonding strength of polyvinyl acetate (PVAc) and casein adhesives in small diameter beech wood

Andromachi MITANI<sup>1</sup>, Ioannis BARBOUTIS<sup>\*1</sup>

<sup>1</sup> Aristotle University, Faculty of Forestry and Natural Environment, Laboratory of Wood Products and Furniture Technology, 54124, Thessaloniki, Greece

### Abstract

As a matter of fact, beech wood is one of the most important commercial hardwood species in southeastern Europe. Beech is utilized mainly as round wood and fuel wood. Overall harvest of beech wood is comparable to those of pine and oak forests. Effective and maximum value use of small-diameter hardwood timber has long been of interest to forest managers and researchers. Gluing or bonding wood has been widely used for many centuries. Moreover, a wide variety of adhesives types is utilised, due to their extensive use in many different applications with wood. Beech wood (*Fagus sylvatica* L.), was used in order to investigate the bond ability of beech wood. For the bonding the used adhesives were PVAc and casein glue, both of D3. The adhesives were applied to one or two surfaces and the half of them were immersed in water in order to investigate the influence of moisture on bonding strength. According to the results, the average modulus of rupture was influenced by the type of adhesive. The samples of beech wood bonded with PVAc had higher modulus of rupture compared to the samples of beech laminated with glue Casein-gap from 1.03 to 2.2 N/mm<sup>2</sup>. Additionally, the highest average modulus of rupture rate recorded in beech samples coated with PVAc on both bonding surfaces reaches 21.05 N/mm<sup>2</sup>. The statistical analysis of the results revealed that the average bonding strength of those samples only air-conditioned, did not show any statistically significant difference from the average bonding strength of the samples immersed in water.

**Key words:** beech wood, bonding, casein, PVAc, shear strength

### 1. Introduction

Effective and maximum value use of small-diameter hardwood timber has long been of interest to forest managers and researchers. In addition to being a significant component of the standing forest base, small-diameter hardwoods often are available after thinning or other tending operations. Although the use of this material is important to achieving healthy and sustainable forests and other ecosystem management objectives, finding economical uses is sometimes difficult (Wiedendek et. al., 2003)

Beech forests indigenously grow in central Europe, in the Balkan peninsula, from Greece and Bulgaria up to the Caucasus along the Black sea region and Turkey. As a matter of fact, beech wood is one of the most important commercial hardwood species in southeastern Europe (Ertekin et. al., 2015). Beech forests in Greece mainly grow at high altitudes on mountains; from mountain Oxia (Central Greece) up to the northern borders. Furthermore, beech wood has an economic importance for Greece along with fir, pine and oak species. Beech is utilized mainly as round wood and fuel wood. Overall harvest of beech wood is comparable to those of pine and oak forests, that is, 300.000 m<sup>3</sup> per year; 75 % of that comes from the public forests. In the Greek market, beech wood is utilized as sawn timber in furniture production, but a large amount is also used for fuel wood, boxes, top benches, pallets, toys and wood-based panels (particleboard, fibreboard). In the past, beech wood used to be treated with oil preservatives. In overall, beech wood is classified as a medium-high density hardwood (Skarvelis and Mantanis, 2010).

Gluing or bonding wood has been widely used for many centuries and it has been estimated that 70% of wood products are adhesive bonded in industrial practice (Gardner, 2006). Moreover, a wide variety of adhesives types is utilised, due to their extensive use in many different applications with wood (Frihart, 2005). Early glues used in furniture manufacturing were made from animals although, initially, they were supported and reinforced by wooden dowels and nails. Synthetic adhesives, qualified to hold parts of furniture even without any assistance, were discovered

\* Corresponding author / Haberleşmeden sorumlu yazar: Tel.: +302310998845; Fax.: +302310998883; E-mail: jbarb@for.auth.gr

in the early 19th century due to the industrial development (Tout, 2000). However, a major disadvantage of the above adhesive was the considerable amount of time it took to harden in ambient conditions. Thus, a new category of adhesives, polyvinyl acetate (PVAc), was developed in 1950's replacing animal glues and a large proportion of the urea- formaldehyde used for almost 300 years. Adhesives used in construction and furniture assembly usually have long set times and are room-temperature cured. Furniture adhesives, in particular, are light-colored, of low-viscosity, and generally do not need much moisture resistance. On the other hand, construction adhesives, possibly being dark-colored generally have high viscosity and need flexibility (Frihart, 2005). Urea- formaldehyde, polyvinyl acetate (PVAc), casein glue, hot melts and polyurethanes are currently used as adhesives in furniture production (Tout, 2000).

Polyvinyl acetate (PVAc) is a thermoplastic adhesive, widely used in furniture, and has the crucial advantage of being harmless to human health and the environment. Casein glue, made from natural raw materials (milk), may contain calcium hydroxide and sodium which improve its properties though nowadays, its use is limited despite its strength and the fact that it shows no creep (Rowland, 1998). Burdurlu et. al. (2007) studied the effect of the wood surface, to be bonded, and the shear strength of beech and pine wood bonded with PVAc and urea formaldehyde. Consistent with the research results, higher shear strength was found in beech bonded with PVAc at bonding pressure 0.9 MPa. In general, PVAc offered better results in all samples, either radially or tangentially planed, compared to urea formaldehyde.

Konnerth et al. (2006) studied the behaviour and durability of beech wood bonded with casein, PVAc and other adhesives in accordance with EN 301-1:2004 standard. Researchers concluded that although PVAc provided better results than casein glue, the resistance did not show any statistically significant differentiation. Shear strength is a frequently used reference parameter for the evaluation of the adhesive bond strength in bonded wood products, as it is the most common interfacial stress under service conditions (Pizzo et. al., 2003).

## 2. Materials and methods

For the preparation of samples, beech wood (*Fagus sylvatica* L.), was used obtained from the market, conditioning in the laboratory for about 1 year under  $20 \pm 2^\circ \text{C}$  and  $65 \pm 5\%$  relative humidity. Wood samples were weighed and then dried in the oven at  $103 \pm 2^\circ \text{C}$  for 24h and reweighed, according to ISO 3130:1975, in order to estimate the mean moisture content and the density of the material. The average density (oven dry weight/volume at current moisture content) and the average moisture content (Eq. 1) of the timber used was  $0.63 (0.01) \text{ g/cm}^3$  and  $8.8 (0.46)\%$ . For the bonding the used adhesives were PVAc polyvinyl alcohol type D100 DUROSTICK manufactured six months before the test was carried out and casein glue powder AURO, both of D3 Class. In accordance with the specifications, the PVAc pH was 2.5 to 3.5, its density was  $1.00 \pm 0.10 \text{ Kg / L}$  and its viscosity ranged between 8000 - 15000  $\text{mPa} \cdot \text{s}$ . The components of casein glue were: casein milk, lime, potash, chalk, borates, carbonates, silicates, and caseinates. The blending ratio of the glue powder and water is (1:1). On the sawn timber used, pairs of plates were prepared 1 cm thick, 12.5 cm wide and 34 cm long. Prior to bonding process, the plates had been planed and lightly smoothed with sandpaper No. 220. The glue spread out with the help of a special comb to the surface of one plate for every pair of plates for half the number of pieces, and for the other half it spread out on both plates. The amount of glue applied to each surface was  $13 \pm 1 \text{ g}$  and it was calculated by weighing each plate separately before and immediately after applying it. Then, each pair of samples was placed in a press applying pressure (0.9 Mpa) for 3 hours. Before the formulation of the final samples (Figure 1, 2), the bonded plate was conditioned for a day until the adhesive's hardening was completed. The final specimens were conditioned for 7 days before the tests at  $20^\circ \text{C}$  and 65% relative humidity. Half the number of the samples was immersed in water at  $20^\circ \text{C}$  for three hours and then they were conditioned for seven days at  $20 \pm 2^\circ \text{C}$  and relative humidity  $65 \pm 5\%$  according to EN 204:2001 standard. The tests were carried out according to standard EN 205:2003 on a universal testing machine (SHIMADZU UH-300kNA). The loading continued until a break or separation occurred on the surface of the test samples and the load speed was 5 mm/min. Fifteen replicated specimens were measured for the each test. Moreover solid wood samples were constructed as testifiers. Statistical analysis of the results was conducted by SPSS (PASW, 18) statistical program and specifically one way analysis of variance (ANOVA) was used to compare the differences of means at the 0.05 level, and determine any significant differences in the effect of the treatment combinations on the bonding strength.

## 3. Results

The measurement results of the tensile shear strength of bonded samples are presented in table 1. According to the results, regarding conditioned samples, the higher strengths were recorded in beech wood samples bonded with PVAc and with double-face glue application. Samples prepared with PVAc had higher bonding strength than  $10 \text{ N/mm}^2$  as required by the EN 204:2001. The statistical analysis of the results indicated that the average bonding strength of solid wood samples did not show any insignificant difference. According to the results (Table 1), the average bonding strength was influenced by the type of adhesive. In most cases, PVAc adhesive gave higher values compared to casein. Specifically concerning double glue application, the PVAc adhesive gave the highest strength in comparison with casein adhesive.



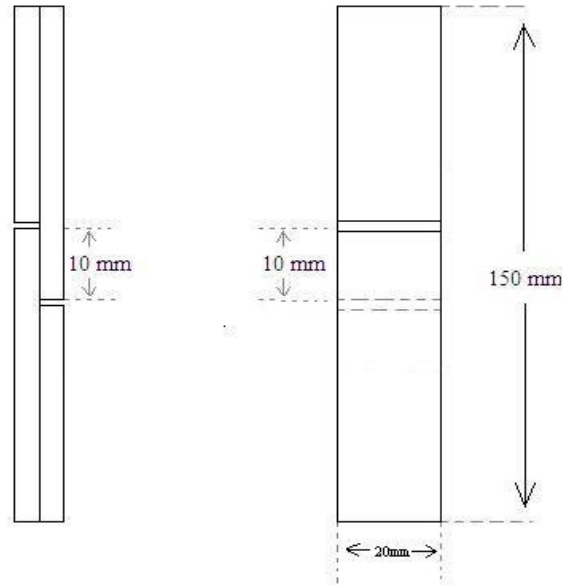

Figure 1. Configuration of the Sample EN 205:2003

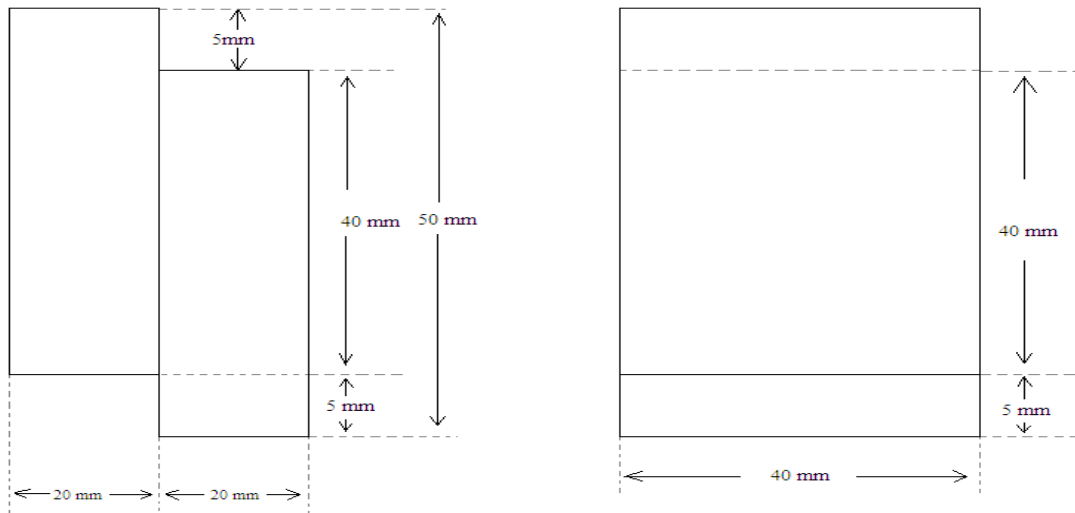

Figure 2. Configuration of the Sample ISO 6238:2001

Table 1. Mean values of tensile shear strength of beech wood

Wood species	Bonding Strength N/mm <sup>2</sup>								Solid wood
	PVAc				Casein				
	Conditioned		Immersed		Conditioned		Immersed		
1	2	1	2	1	2	1	2		
<b>Beech</b>	13.83* (2.25)	15.79 (0.63)	11.31 (1.11)	12.67 (1.78)	14.30 (3.12)	14.79 (1.05)	12.37 (2.41)	13.26 (3.04)	15.13 (1.40)

\* Mean values of 15 samples with standard deviations are referred in parentheses. 1: Single surface glue application, 2: Double surface glue application, Conditioned: Specimens conditioned at 20°C and 65% relative humidity, Immersed: Specimens immersed in water

On the other hand, it was found that the samples tested after the immersion, in most cases, retained their strength higher than 10 N/mm<sup>2</sup>. According to the statistical analysis of the results given, the beech wood samples bonded with PVAc in single glue application differed statistically compared to solid wood. The statistical analysis of the results revealed that the average bonding strength of those samples only air-conditioned, did not show any statistically noticeable difference from the average bonding strength of the samples immersed in water. As seen from the results (Table 1) the average bonding strength was influenced by the choice of the adhesive coating either on one of the two or both bonding surfaces of the samples. It was observed that the samples coated on both surfaces with PVAc and casein have greater bonding strength compared to one side coated ones for most types of wood samples while statistical analysis shows that the average bonding strength of samples did not differ statistically significantly. Ozcifici et al. (2008) studied the influence of mechanical surface treatment of wood to be bonded with phenol formaldehyde, PVAc, urea formaldehyde and polyurethane, using beech, oak, pine and poplar woods. According to results, the higher strength samples were recorded in beech bonding with PVAc (14.83 N/mm<sup>2</sup>) in comparison with oak wood presented slightly lower values (13.68 N/mm<sup>2</sup>) and they concluded that beech bonded with PVAc is a great option for wooden constructions production.

Table 2. Mean values of shear strength of beech wood

Wood species	Bonding Strength N/mm <sup>2</sup>				Solid wood
	PVAc		Casein		
	1	2	1	2	
<b>Beech</b>	19.98 (1.36)*	21.05 (3.19)	17,78 (1.65)	20.02 (1.72)	19.93 (0.81)

\* Mean values of 15 samples with standard deviations are referred in parentheses. 1: Single surface glue application, 2: Double surface glue application

According to the results (Table 2) the average modulus of rapture was influenced by the type of adhesive. The samples of beech wood bonded with PVAc had higher modulus of rapture compared to the samples of beech laminated with glue Casein-gap from 1.03 to 2.2 N/mm<sup>2</sup>. It was also found that the laminated beech samples recorded higher modulus of rapture than those of solid wood except from the single-face glue application samples bonded with casein, which showed a decrease of 2.15 N/mm<sup>2</sup>. According to the statistical analysis of the results given the two types of adhesive did not present an important difference statistically. Finally, it should be noted that the highest average modulus of rapture rate recorded in beech samples coated with PVAc on both bonding surfaces reaches 21.05 N/mm<sup>2</sup>. The statistical analysis of results shows that the average modulus of rapture of samples coated with adhesive on one surface do not significant differ statistically by the average modulus of rapture of samples coated in both bonding surfaces.

**References**

Burdurlu, E., Usta, I., Kilis, Y., Ulupinar, M. 2007. The effect on shear strength of different surfacing techniques in Oriental beech (*Fagus orientalis* Lipsky) and Scotch pine (*Pinus sylvestris* L.) bonded joints. Journal of adhesion science and technology, 21, 3-4, 319-330(12).

Cassens, D. 2007. Hardwood lumber and veneer series-Basswood. Purdue University. Purdue extension. FNR-274-W.

EN 205, 2003. Adhesives. Wood adhesives for non-structural applications. Determination of tensile shear strength of lap joints.

EN 204, 2001. Classification of thermoplastic wood adhesives for non-structural applications.

Ertekin, M., Kırdar, E., Ayan, S. 2015. The effects of exposure, elevation and tree age on seed characteristics of *Fagus orientalis* Lipsky. *South-east Eur for* 6 (1): 15-23. DOI: <http://dx.doi.org/10.15177/seeefor.15-03>

Frihart, R. Charles 2005. USDA, Forest service, Forest products laboratory, Madison, WI: Wood adhesion and adhesives. Handbook of wood chemistry and wood composites.

Keskin, H., Atar, M., Akyildiz, H. 2009. Bonding strengths of polyvinyl acetate, desmodur-VTKA, phenol-formaldehyde and urea-formaldehyde adhesives in wood materials impregnated with Vacsol Azure. *Materials and Design*. 30, 3789-3794, Turkey.

Konnerth, J., Wolfgang, G., Harm, M., Muller, U. 2006. Comparison dry strength of spruce and beech wood glyed with different adhesives by means of scarf- and lap joints testing method. *Holz als Roh- und Werkstoff*. 64: 269-271. Austria

- Özçifci, A., Yapici, F. 2008. Effects of machining method and grain orientation on the bonding strength of some wood species. *Journal of materials processing technology*. 202, 353-358. Turkey.
- Pizzo, B., Lavisci, P., Misani, C., Triboulot, P., Macchoni, N. 2003. Measuring the shear strength ratio of glued joints within the same specimen. *Holz Roh-Werkst.* 61:273-280.
- Pohler, E., Klingner, R., Kunniger, T. 2005. Beech (*Fagus sylvatica* L.) - Technological properties, adhesion behavior and colour stability with and without coatings of the red heartwood. Switzerland.
- Rowland, G. Adhesives and adhesion. 1998. *CHEM NZ*. No 71, 17-27.
- Skarvelis, M., Mantanis, G. I. 2010. Physical and mechanical properties of beech wood harvested in the Greek public forests. *Wood Researches*, 58 (1).
- Tout, R. 2000. A review of adhesives for furniture. *International Journal of Adhesion & Adhesives*. Elsevier science Ltd. 20, 269-272.
- Vassiliou, V., Barboutis, I., Karastergiou, S. 2000. Bending strength properties of finger-joined with PVAc glue beech wood. *Scientific anniversary of Forestry and Natural Environment Faculty*. 43 .513-529.
- Gardner, D.J. 2006. Adhesion mechanisms of durable wood adhesive bonds. in D.D. Stokke, L.H. Groom (Eds.), *Characterization of the Cellulosic Cell Wall*. Chapter 19, 254 – 265. Blackwell Publishing.
- Wiedenbeck, J. K., Blankenhorn, P. R., Scholl, M., Stover, L. R. 2003. Small-diameter hardwood utilization with emphasis on higher value. [www.ncsu.edu/feop/symposium/proceedings\\_2003](http://www.ncsu.edu/feop/symposium/proceedings_2003)
- Matthew, S., Bumgardner, Bruce G., Hansen, Albert T., Schuler and Philip, A. 2000. Araman Options for small diameter hardwood utilization. Past and present. *Proceedings of the Annual Meeting of the SOFEW*.

*(Received for publication 27 July 2015; The date of publication 15 August 2016)*



## Wood production potential of beech (*Fagus sylvatica* L.) from natural forests in West Central Greece

Dimitrios KOUTSIANITIS<sup>1</sup>, Elias VOULGARIDIS<sup>1</sup>, Andromachi MITANI\*<sup>2</sup>

<sup>1</sup>Laboratory of Forest Utilization, School of Forestry and Natural Environment, Aristotle University, Thessaloniki, 54124, Greece

<sup>2</sup>Laboratory of Wood Technology, School of Forestry and Natural Environment, Aristotle University, Thessaloniki, 54124, Greece

### Abstract

Beech is an important tree species in natural and managed forests in Europe. Beech natural forests in Greece have a great ecological and economic importance and represent a very valuable species with respect to its potential of wood production and utilization. The aim of this work was to analyze the wood production potential of beech (*Fagus sylvatica* L.) natural forests on a quantitative and qualitative basis with respect to the forest site quality conditions. For this analysis, the wood production potential of 228 beech trees growing under different site qualities at the Aspropotamos forest district, Trikala, western-central Greece, was evaluated. For the quality grading of 787 produced beech logs, the EN 1316-1:1997 CEN standard was employed. The results showed that there is a very good potential of both quantitative and qualitative wood production in the natural beech forest as well as that the site quality has an influence on quantity and quality of wood production. It was recorded that beech trees grown under the better site quality, have attained the highest mean ring increment and produced the highest quantities of wood. Particularly, higher production and better quality of beech wood was produced in the better site quality, while in the inferior site quality the quantity of round wood produced was less and the quality was inferior.

**Key words:** beech, wood production, quality of wood, site quality

### 1. Introduction

Tree as a living biological unit of a forest, appears in a variety of forms and characteristics regarding stem morphology as well as wood properties, due to a combination of genetic and environmental factors, as long as it grows. Hence, the qualitative features and characteristics created by this procedure determine the potential value of the tree stem and its wood products, according to market and productive process requirements. Wood shows a large variation in properties, between species and trees, under different growth conditions, as well as within each tree. The variability of wood as raw material is necessary to be taken into account and, hence, improved procedures are needed to predict properties of trees and logs, in order to allocate the wood in an optimal way to different products of better quality. Qualitative defects cannot only primarily derive from tree's growth rate and growth conditions but also, secondarily, from harvesting conditions and management systems in the forest and mechanical processing conditions in forest industries (Voulgaridis, 2002; Tombaziotis and Voulgaridis, 2006; Ayan et al., 2012).

The site where trees grow refers to a geographic location that is considered homogeneous in terms of its physical and biological environment. Forest site is defined by the location's potential to maintain tree growth, often with a view to site-specific silviculture. It may be classified into site types according to their similarity regarding soil, topography, climate and vegetation. Site classification can provide a range of management aims, including ecological stratification for optimizing the evaluation of forest site productivity. In that sense, site productivity is defined as the potential of a particular forest stand to produce aboveground wood volume, and is related to the site quality (Skovsgaard and Vanclay, 2008). When growth conditions deteriorate in natural forest ecosystems (e.g., through a reduction in soil fertility) a forest community adapts to the new environmental conditions with slower growth and species' substitution. However, this change does not imply an inevitable decrease in productivity because nutritionally more efficient species can increase in dominance (Goncalves et al., 2004). A study by Kirdyanov et al. (2013) revealed the dependence of tree

\* Corresponding author / Haberleşmeden sorumlu yazar: Tel.: +306975857033; Fax.: +302310998883; E-mail: amitani@hotmail.com

growth on local site conditions, as soil factors dramatically influenced tree ring formation and therefore wood productivity changed. Dafis (1969) reported that in the better site qualities beech species show the maximum productive capacity, in the intermediate site qualities beech presents less but sufficient productivity, while in the inferior site qualities beech stands indicate small productivity and low timber quality.

The relationships between wood quality, silvicultural system and environmental conditions (i.e., site quality) are established through biological (i.e., height growth, stem radial growth), environmental (i.e., competition for resources) and biomechanical processes and limitations (Kellomäki *et al.*, 1999). In this context, the relation between the growth conditions of forest trees and the structural characteristics of their wood produced has been examined by several investigators. Tsoumis and Panagiotidis (1980) investigated the effect of geographical location, social position of trees in a forest stand and site quality and found that wood produced in high or intermediate site qualities exhibited greater quality characteristics. Gutierrez-Oliva *et al.* (2006) also concluded that site quality had considerable influence on the wood density values, where the highest values were found in the best site qualities. Farrelly *et al.* (2009) investigated the effect of forest site conditions on the productivity of Sitka spruce. Their study revealed that the highest productivities occurred on forest sites with deep, moist, well-aerated soils, of moderate to rich nutrient status, whereas the lowest growth potential was on poor sites, due to poor drainage and low nutrient level. Houllier *et al.* (1995) reported on a project modelling the influence of site quality on individual tree growth, on stand yield and on wood quality of Norway spruce. They claim that this framework can be used either to establish statistical relationships between growth and wood quality or to model some of the processes that determine wood quality. Liu *et al.* (2005) studied the variation of color in trees under different growing conditions and management practices. Their study revealed a significant effect of site conditions on color variation and red heartwood development, which devalue beech timber.

Quality grading of forest products and particularly of round wood is of great importance to the timber market, since it specifies the usage, constitutes the base for trading and finally greatly influences market prices. Standards are applied to the quality classification of round wood. European countries apply their national standards or European standards where they exist. Quality classification of round wood in state forests in Greece is based on visual appearance of logs and their dimensions (length and diameter). Both softwood and hardwood species are assorted into three main quality classes: A (superior quality timber, top quality sawn timber), B (normal or less valuable quality timber) and C (inferior quality timber) (Tsoumis, 1991; Voulgaridis, 2002).

The quality and quantity of wood production from different sites of beech natural forests have been the subject of limited research so far, and, in Greece, such research is lacking. The aim of this work was to analyze the wood production potential of beech (*Fagus sylvatica* L.) natural forests on a quantitative and qualitative basis with respect to the forest site quality conditions. Such investigations are expected to better evaluate the influences of growth conditions on the quantity and quality of the timber produced, and to improve existing timber quality assessment procedures with respect to final product requirements.

## 2. Materials and methods

### 2.1 General information of the stands and tree selection

As experimental area, the stands numbered 11b and 28d of the forest sites “Elatos” and “Kastania”, respectively, at the Aspropotamos forest district of Kalampaka, western-central Greece, were selected according to their corresponding forest management plans. These two forest stands are characterized by variable landscapes and environmental conditions. General information of the stands selected and the number of the investigated trees per site quality are shown in Table 1.

In total 228 marked beech trees, which were scheduled to be cut and logged in summer 2012, were investigated. According to the forest management plan of the investigated forest district, the study focused on site qualities II and III. The distinction of the different site qualities in the selected forest stands was conducted using the site quality maps of the management plan. Additionally, tree height and breast height diameters were measured in the two experimental forest stands, in order to confirm the existing map data for site qualities (Dafis, 1969). In addition, quality data of standing trees like stem crook, forked stem, sweep, vertical position, irregular perimeter, branchless height, health condition, etc., were taken.

Table 1. General information on forest stands and number of trees per site quality investigated

Species	Stand	Area (ha)	Elevation (m)	Orientation	Slope (%)	Site quality/Exp. area (ha)		Number of trees	
						II	III	II	III
Beech	11b	31,69	1190-1510	N-NE	40-70	12,00	12,00	93	65
	28d	33,4	1200-1400	N-NE	50-70	17,00	14,00	38	32
Total beech trees investigated per site quality								131	97

Trees were classified into 8 diameter classes based on their stem diameter at breast height. Tree diameter ranged from 29 to 60 cm and a 4 cm scale was used for the classification of the above mentioned classes (Table 2). When trees were cut, tree height, crown height, and unbarked diameter at the middle of the tree stem were measured. Each log of the tree obtained was given a serial number. Based on the tree height and the diameter of the stem, tree volume was calculated. Additionally, the age of each tree was measured at the tree base that is the surface of stump cross section. Based on the diameter at the base of the tree and the number of annual rings, mean ring width was calculated.

Table 2. Classification of investigated trees into 8 diameter classes and distribution of trees per diameter class and site quality

Class	1	2	3	4	5	6	7	8
Diameter [cm]	29-32	33-36	37-40	41-44	45-48	49-52	53-56	57-60
Beech								
II	10	11	16	26	25	17	15	11
III	8	8	11	18	21	12	10	9
Total	18	19	27	44	46	29	25	20

## 2.2. Roundwood quality assessment

Trees were cut and converted to (produced) 787 beech logs. All sides of the logs were inspected, and all features were checked, recognized, classified and measured manually. The diameter, volume and defects of each log were recorded in detail on special forms. Sorting criteria for appearance evaluation were based on determination of size and quantity of individual logs characteristics such as type and size of knots, rate of growth, spiral grain, eccentric pith, shakes, taper and sweep of logs, tension wood, red heart, fungal and insect attacks, rot, discoloration (stain), double pith, ovality, fluting, checks, splits (Tsoumis 1961; 1991) and formation and level of the heart rot (Ayan et al., 2012). Furthermore, images from 787 beech freshly cut logs and their butt ends, were taken with a digital camera (Sony DSC-W115) and were processed on a PC using digital camera analysis software (Adobe Photoshop). These images were used to check the accuracy of the visually estimated defects in the field. For grading of beech produced logs, EN 1316-1 (1997) was employed to set the threshold values for four quality grades: A – an exceptional quality class, B – a normal quality class, C – a less valuable quality class and D – a quality class which includes long pole, log or portion of long pole not permitted in the other quality classes (for all the characteristics in class D more than 40% of the volume of the wood shall be usable). Quality classes are not applied to small sized timber (wood 1 m long, used for particleboards, fiberboards and pulpwood) and fuelwood of short length (used as a fuel). The assessment followed the log grading standards in full terms.

## 3. Results

### 3.1. Quantitative production

From the total number of 228 beech trees, 131 were present in site quality II and 97 in site quality III. The produced beech round wood varied between 3, 4 and 5 m long. Based on Skovsgaard and Vanclay (2008) the maximum mean annual volume increment is considered a more suitable measure of site productivity than an index based on stand height or height growth. An index that represents volume production allows for direct and meaningful comparisons across species, site types and growth regions compared to an index based on stand height at a certain age. Tree ring width is an indicator of volume production. The results of the mean ring width calculated from the 228 beech stump cross sections in relation to diameter class of the studied trees and site quality, are shown in Figure 1.

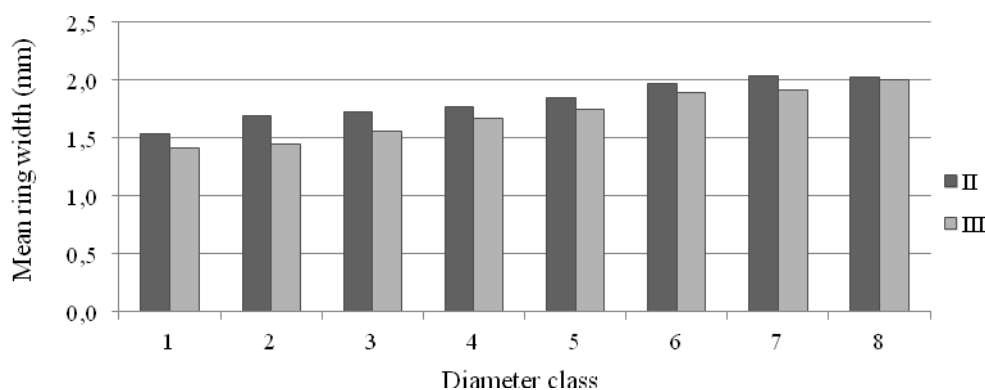

Figure 1. Mean ring width of investigated trees in relation to diameter class and site quality

The mean ring width of beech trees of site quality II is approximately 7 % higher than the mean ring width of the inferior site quality III (Table 3). This difference was confirmed as significant from the ANOVA-test. Hence, the better site quality was directly connected with the higher mean annual volume production than in poorer site quality and therefore with the site productivity. Thus, certain differences in growth potential were evident among beech trees of the same diameter class growing under different site conditions. It turned out that beech tree species growing in the rich site quality II attained the highest mean ring increment. According to Spanos (2011), the wood production of beech stands in Greece is lower than that of fir (*Abies* spp.) and Norway spruce (*Picea abies*) and only under proper silviculture conditions, beech can produce higher amount of round wood, in comparison to other broadleaves and conifers.

Table 3. Calculated mean values and variances of the tree ring width and height for statistical evaluation (ANOVA)

		Ring width		Tree Height	
		Mean value	Std. Deviation	Mean value	Std. Deviation
Beech	II	1,84	0,22	27,46	3,42
	III				

[ : Statistically significant differences at 5% level of significance

The results of the mean tree height measurements in relation to diameter class of the studied trees and site quality are shown in Figure 2. The highest mean tree height of beech was found in site quality II. The mean tree height for beech in site quality II is approximately 12.5 % higher than the mean tree height in site quality III. This difference was confirmed as significant from the ANOVA-test (Table 3). Skovsgaard and Vanclay (2008) suggest that the use of height or height growth as a site productivity indicator relates to the fact that, in many situations, stand height or current height growth seems to correlate well with stand volume growth. In addition, they claim that height is a simple variable, easy and inexpensive to measure and generally not much affected by management practices. The mean volumes of round wood and small sized timber plus fuelwood production in relation to diameter class and site quality are shown in Figure 3. The volume of each log was calculated, all volumes of the same diameter class were added and the mean volume was calculated. The round wood production appears to be higher in better site quality, while the differences of small sized timber plus fuelwood production between the site qualities were found to be small.

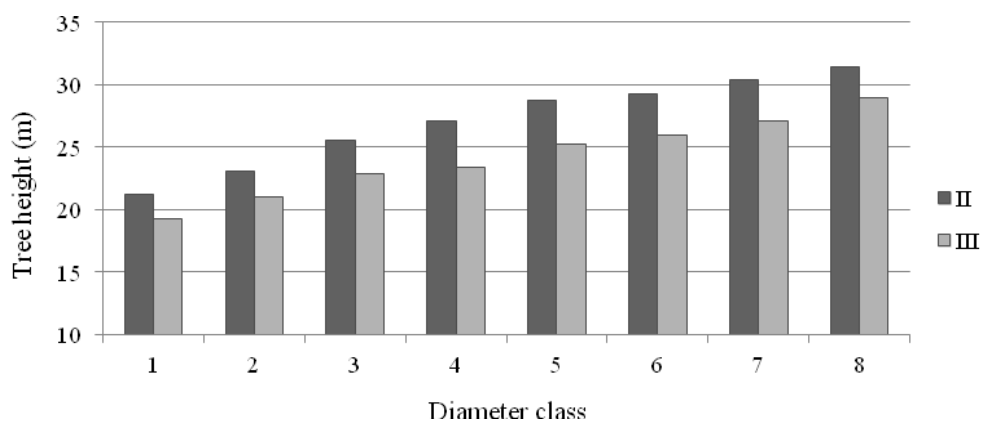

Figure 2. Mean tree height of investigated trees in relation to diameter class and site quality

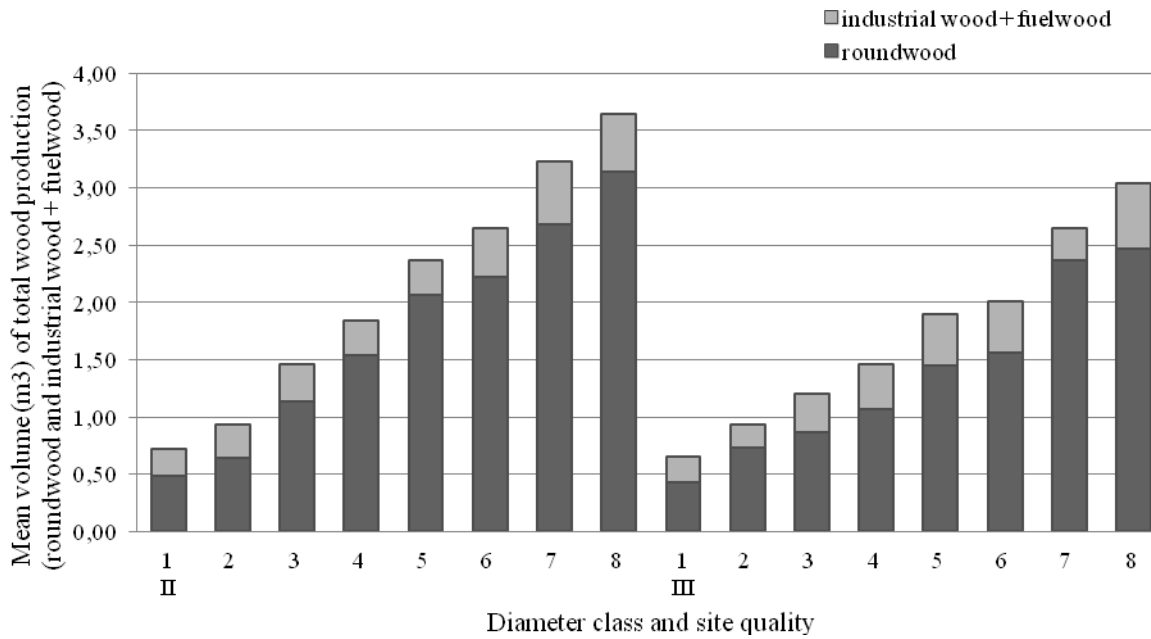

Figure 3. Mean stem volume production (roundwood and small sized timber plus fuelwood) for beech, in relation to diameter class and site quality

1.2. Qualitative production

The quality assessment according to EN 1316-1 (1997) grading standard classified the round wood by a range of different characteristics and properties which had to meet particular limits. In this way, the parameter which presented the lowest quality of the log determined the overall classification of the log. However, there were some exceptions where an extremely benign performance in one characteristic compensated a small deviation from the required limit in another characteristic. This work revealed that the main defects that cause most downgrading of beech round wood were knots, red heart and to a small extent tension wood. All volumes of the same quality class were added and the total volume of each quality class was expressed as a percentage of the total round wood production.

Figure 4 shows the qualitative classification of the round wood obtained from 228 beech trees, separately for the investigated site qualities II and III. In site quality II, the percentages of beech round wood produced as A and B quality classes were significantly higher (24 % for A and 53 % for B) than those in site quality III (9 % for A and 45 % for B). On the contrary, the percentages of round wood produced as C and D quality classes increased from II to III site quality, from 22 to 39 % (class C) and from 1 to 7 % (class D). Wood production analysis per tree diameter class showed that by increasing the tree diameter, the percentages of the produced beech round wood corresponding to four quality classes A, B, C and D did not follow any consistent trend from II to III site quality.

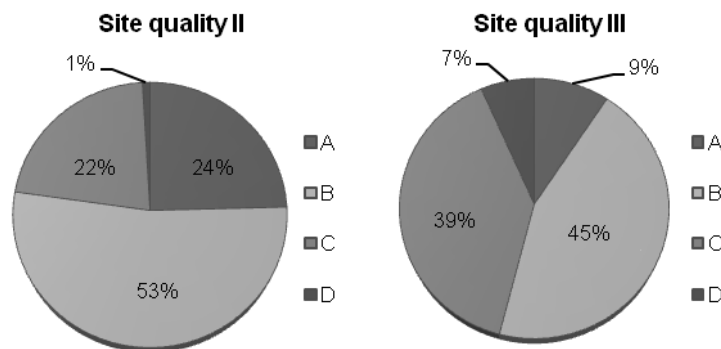

Figure 4. Qualitative production of beech round wood in relation to site quality

4. Conclusions and discussion

The conclusions of the present investigation on qualitative and quantitative wood production of beech natural forests can be summarized as follows:



Certain differences in growth potential were found to exist among beech trees of the same diameter class grown in different site qualities. It was recorded that beech trees grown in site quality II, have attained the highest mean ring increment and produce the highest quantities of wood when compared with the inferior site quality III.

The natural beech forests exhibit a potential to produce more timber of higher wood qualities (A and B class) in the better site quality II (77 % of the total wood volume produced) than in the inferior site quality III (54% of the total wood volume produced). The round wood production of inferior quality (C and D classes) was increased from the better site quality (II) to inferior site quality (III).

The results of this work indicate that, under the specific experimental conditions, natural beech forests produce higher quantities of better quality round wood when they are grown in better site qualities than in inferior ones. The application of proper silvicultural measures, training of forest workers and application of roundwood quality grading standards is expected to increase the percentages of beech round wood production of better quality in all site qualities..

## References

- Ayan, S., Acar, S., Yer, E. N., Bulut, A., 2012. The occurrence of heart rot on *Abies nordmanniana* subsp. *bornmülleriana* Matff. trees in relation to altitude, Kastamonu Univ., Journal of Forestry Faculty, 12/3 Special Issue; 196-202.
- Dafis S. 1969. Stathmological studies in beech forests. Scientific Annals of the School of Agriculture and Forestry, Aristotle University of Thessaloniki, Greece, 48 pp (In Greek with German summary)
- EN 1316-1: 1997. Hardwood round timber – Qualitative classification Oak and beech – Part 1. Oak and beech. European Committee for Standardization, Brussels.
- Farrelly N, Ni Dhubhain A, Nieuwenhuis M, Grant J. 2009. The distribution and productivity of Sitka spruce (*Picea sitchensis*) in Ireland in relation to site, soil and climatic factors. Irish Forestry 66(1&2): 51-73
- Goncalves J.L.M., Stape J.L., Laclau J.P., Smethurst P, Gava J.L. 2004. Silvicultural effects on the productivity and wood quality of eucalypt plantations. Forest Ecol Manag 193/1: 45-61
- Gutierrez-Oliva A., Baonza-Merino V., Fernandez-Golfin-Seco J.I., Conde-Garcia M., Hermoso-Prieto E. 2006. Effect of growth conditions on wood density of Spanish *Pinus nigra*. Wood Sci Technol 40(3): 190-204
- Houllier F., Leban J., Colin F. 1995. Linking growth modelling to timber quality assessment for Norway spruce. Forest Ecol Manag 74(1): 91-102
- Kellomäki S., Ikonen V.P., Peltola H., Kolström T. 1999. Modelling the structural growth of Scots pine with implications for wood quality. Ecol Model 122(1&2): 117–134
- Kirdyanov A.V., Prokushkin A.S., Tabakova M. A. 2013. Tree-ring growth of Gmelin larch under contrasting local conditions in the north of Central Siberia. Dendrochronologia 31: 114-119
- Liu S, Loup C, Gril J, Dumonceaud O, Thibaut A, Thibaut B. 2005. Studies on European beech (*Fagus sylvatica* L.). Part 1: Variations of wood colour parameters. Ann For Sci 62/7/: 625 – 632
- Skovsgaard J.P., Vanclay J.K. 2008. Forest site productivity: A review of the evolution of dendrometric concepts for even-aged stands. Forestry 81(1):13-31
- Spanos KA (2011) Beech forest genetic resources in Greece: their importance and conservation value. Adaptive strategy under climate change. In: Genetic resources of European beech (*Fagus sylvatica* L.) for sustainable forestry, INIA, Madrid, pp 93-113
- Tombaziotis M, Voulgaridis E.V. 2006. The appearance of compression wood in hybrid fir trees (*Abies borisii regis* Matff.) and its impact on the quality of sawn timber. Proceedings of the 5th IUFRO Symposium, 3-6 September, Sliac-Sielnica, Slovakia, pp 155-162
- Tsoumis G. 1961. Grading fir logs and lumber in the University Sawmill at Pertouli. Scientific Annals of the School of Agriculture and Forestry, Aristotle University of Thessaloniki, Greece, pp 103-135 (In Greek with English summary)
- Tsoumis G. 1991. Science and Technology of Wood: Structure, Properties, Utilization. Van Nostrand Reinhold, New York, 494 pp.
- Tsoumis G., Panagiotidis N. 1980. Effect of growth conditions on wood quality characteristics of black pine (*Pinus nigra* Arn.). Wood Sci Technol 14/4: 301-310
- Voulgaridis E. 2002. Wood Quality (University Lectures), University Press, Thessaloniki, Greece, 128 pp (In Greek)

(Received for publication 08 April 2015; The date of publication 15 August 2016)



## Variability and breeding of beech (*Fagus moesiaca/Domin, Maly/Czeczott.*) in Serbia

Vasilije ISAJEV<sup>\*1</sup>, Vera LAVADINOVIĆ<sup>1</sup>, Ljubinko RAKONJAC<sup>1</sup>, Vladan POPOVIĆ<sup>1</sup>

<sup>1</sup>Institute for Forestry, 11030 Belgrade, Serbia

### Abstract

Beech breeding is mostly directed to the conservation of genetic resources, the selection of the corresponding provenances for different sites, enhanced production and trade of planting stock, study of the species evolution development, and the establishment of live archives and seed orchards. The biochemical and molecular analyses based on the selected population and individuals of different beech stands in Serbia concluded that the adaptation and survival at population level are favored by higher genetic diversity whereas at the individual level it is favored by higher degree of heterozygosis. Breeding of beech in Serbia, depending on the current requirements of forestry and on the state of forests, should be performed in two directions: in the direction of improving the natural populations and in the direction of obtaining the new selected beech genotypes and hybrids, which will have superior target characteristics than the existing types. The previous research shows that there are genetic differences between beech populations in Europe and Serbia. This requires the programs of closer research and of directed application of beech genetic variability.

**Key words:** beech, variability, breeding, Serbia

### 1. Introduction

The economic significance, as well as the general biological-ecological characteristics of beech (Ertekin et. al., 2015) has made this species in its range the subject of interest of a great number of scientists and professionals for more than a hundred years. Based on the study results of bioecological, production and technical-physics characteristics of beech wood, it was decided to investigate the cause of the recorded ecological, morphological and physiological variability also by the methods of genetics and plant breeding (Isajev, 2005). The choice of basic methods and the corresponding variants of the basic methods of beech breeding in Serbia depended on: 1. the study of its bioecological characteristics; 2. coeno-ecological characteristics of its populations; 3. assignments that are to be worked out; 4. importance of their solution for economy.

The general ecological features of the region in Serbia where pure and (or) mixed beech populations occur spontaneously in interaction with their gene pool, condition the occurrence of the expressed variability of a major number of its morphological and genetic-physiological characteristics. As Moesian beech - (*Fagus moesiaca/Domin, Maly/* is distinguished by high individual and group variability, and as it has numerous intraspecific taxa – varieties, biotypes and ecotypes, this requires a multidisciplinary and complex approach in further work on the research and the directed use of group and individual variability.

This paper surveys the results of the study of genetic potential and variability of beech in Serbia. The presented results are based on longterm analyses of individual and group variability of beech morphological and physiological characters; comparative studies by provenance tests; the review of experiences in the implementation of the results of biochemical and molecular analyses at the level of the selected populations and individuals of different provenances.

### 2. Materials and methods

The protection and directed use of the most valuable beech genetic resources is realised mostly:  
*in situ* - by the selection of the best beech natural populations and by the revision of the existing and the selection of the new seed stands, groups, individual trees, and  
*ex situ* – by the establishment of provenance tests, live archives, clonal and seedling seed orchards.

\* Corresponding author / Haberleşmeden sorumlu yazar: Tel.: +9xxxxxxxxxxxxxx; Fax.: +9xxxxxxxxxxxxxx; E-mail: xxxxxxxx

By the implementation of the method of simple mass selection, 19 beech seed stands were designated with the total area of 137.57 ha. Parallel with the mass selection, individual selection was also undertaken, the selection of test trees for the initial material in the application of synthetic methods of breeding. In this aim, on 17 sites in the central region of Serbia, 74 test trees were selected, of which one was in the sub-alliance *Fagenion moesiaca submontanum* Jov., 1976, 40 individuals were in the sub-alliance *Fagenion moesiaca montanum* Jovanović M. 1976, and 33 trees were in the sub-alliance *Abieti-Fagenion moesiaca* Jovanović M., 1976. The test trees were merely evaluated based on their phenotypes. The more precise insight into their genotypes was to be attained in the later phase of research by early tests on the generative progeny. In this way it will be checked if really the best specimens of this species in Serbia have been selected. In the aim of their conservation, it was decided to protect them from felling and to propagate them asexually in a sufficient number so that the produced vegetative copies, which contain the same genetic base as parent trees from which they originate, could be used in further breeding. Therefore, four methods of grafting were researched comparatively, Jovanović M. 1971:

- a) method of side grafting on overtopped rootstocks, using normal buds;
- b) method of side grafting on overtopped rootstocks, using dormant buds;
- c) method of side grafting on non-overtopped rootstocks using normal buds and
- d) method of wedge grafting, using normal buds (Figure 2).

In auto-vegetative propagation of beech with air layering (Figure 8), using growth stimulators such as beta-indole acetic acid at therates of 0.5 and 1.0% and beta-indole butyric acid at 0.5%;

Genetic variability of common beech was studied using genetic markers in six autochthonous populations, aging from 110 to 160 years which represented the cross section of the stands at the altitude (550-960 m). The samples for these analyses were the protein markers from beechnut, and the applied method was electrophoresis, which is a simple and fast analytic method. The genetic component of the research is based on the analysis of RAPD markers from bulk samples, using 28 primers. The spatial component of the research is based on the geographical position of the studied populations. Grouping of the studied populations in the regions, as well as their separation, was performed using the Monmonier's algorithm of maximum differences. To visualize the results and mapping the regions of beech provenances in Serbia, GIS was used, with database included the results of this study.

### 3. Results

Group variability of beech in Serbia was studied in detail by mass selection. Seed stands were designated and the quality of phenotype characteristics of trees was evaluated and studied (Glišić, 1960; Jovanović, 1961; 1971; Marić *et al.*, 1961, 1962; Tucović, 1970, 1976; Isajev *et al.*, 2003). These papers improved the basic guidelines for the evaluation, selection and management of seed stands. The number of selected beech seed stands depended on the phenotypic characters of the trees and the ecological diversity of the sites of beech forests. The species with an extensive range of distribution, such as beech, have a greater genetic differentiation of the population which spontaneously occur at different localities. When the species is characterised by a marked variability of continuous and discontinuous characters, it is necessary to select a greater number of seed stands. Based on the method of simple mass selection, 19 beech seed stands were selected, total area 137.57 ha, Figure 1.



Figure 1. Seed stand of beech in MU Kukavica, compartment 54 Vladičin Han (By photo V. Ivetić, 2001).

The spatial pattern of the seed stand localities reflects almost completely the coeno-ecological, ecological and population diversity of beech in Serbia. The results of spatial analysis of genetic diversity have practical application in the definition and delineation of regional provenances of forest trees (Ivetić et al. 2008; 2010; 2012). Research was based on the material from 27 natural populations of beech in Serbia. The genetic component of the research is based on the analysis of RAPD markers from bulk samples, using 28 primers. The spatial component of the research is based on the geographical position of the studied populations. Grouping of the studied populations in the regions, as well as their separation, was performed using the Monmonier's algorithm of maximum differences, Monmonier, M.S., 1973. To visualize the results and mapping the regions of beech provenances in Serbia, GIS was used, with database included the results of this study. Combining of GIS tools with molecular genetics technology increases the strength of results, by using the spatial dimension of information they provide and thus provides an alternative perspective that may lead to a better understanding of genomic functions. Visualization (spatial analysis research) and presentation (mapping) the spatial distribution of genetic data is likely to emphasize the patterns of diversity and thus further improve the interpretation of results. This map was used to compare genetic to geographic barriers, as well as drawing maps of regions of provenances map 1. Furthermore, spatial analysis may allow the detection of relations between the regions of the genome, and habitat characteristics which surrounding the populations.



Map 1. Delineation of regions of beech provenances in Serbia, based on Monmonier's geographical barriers obtained from corrected genetic distance (Ivetić et al., 2012).

Based on the above, it can be expected that the collected seeds and the produced planting material will encompass the genetic potential of beech in Serbia. Our previous experience, gained by the beechnut collection and trade, indicates that the best results are achieved when its collection, processing and trade are organised at the local level.

In each beech seed stand the following is organised and executed:

- 1) short-term and
- 2) long-term activities, which include also the planning of the adequate structure of personnel, equipment and material.

The isoenzymatic analysis resulted in the information on the genetic base of the adaptation of common beech populations to the sites at different altitudes. There are different genetic structures among the populations, and the frequency of individual alleles changes significantly from the lower towards the higher altitudes. The results of the above studies indicate that the reproductive material from beech stands from the lower altitudes, before the transfer to the higher altitudes, should be controlled by tests and vice versa. The above genetic specificities of beech populations should be taken into account in the activities directed to the conservation beech genetic resources.

The study results support the hypothesis that beech during the ice age was present in the micro-refuges in the south-east Alps and in a part of Slovenia. The populations from Central and Southeast Europe can be divided into two different groups: the first and greater group consists of the populations from the northwest part of the study area, while the second group consists of the populations from the east Balkan Peninsula. The differentiation in that part could confirm the existence of a special taxon on Balkan, the subspecies *Fagus sylvatica subsp. moesiaca* (Maly) Czecht.,

Gömöry *et al.*, 1999. Based on the results of biochemical and molecular analyses at the level of the selected populations and individuals of different beech provenances in Europe, it can be concluded that, in the changed ecological conditions, the ability of adaptation and survival at the level of populations, was favoured by a higher genetic variability, and at the individual level, by a higher degree of heterozygosis.

The analysis of genetic potential of test trees also used the methods of heterovegetative and auto-vegetative propagation. The most frequently applied method was the heterovegetative propagation – grafting, mostly performed in the glasshouses of the Institute of Forestry and the Faculty of Forestry in Belgrade.

In grafting, special attention was focused on the following properties: quality of rootstock and scions, time of taking, length and method of keeping the scions till the moment of grafting, age of wood for scions, as well as the grafting method.

The grafting (Figure 2) in the glasshouses started in the middle of March and in the open in the first half of April. It ended by the end of April, more rarely at the beginning of May. During the summer grafting in the open, when the budding method was applied, the optimal time for grafting was the beginning or the middle of the second half of August, and it lasted for 7-10 days.



Figure 2. One- year- old grafts of beech produced by triangulation (By photo: M. Jovanović)

In auto-vegetative propagation of beech by air layers, Figure 3, using growth stimulators such as beta-indole acetic acid in concentrations 0.5 and 1.0% and beta-indole butyric acid in concentrations 0.5; 1.0 and 2.0%, the results were excellent, i.e. the percentage of rooting was from 90 to 100%,(Jovanović, 1971). Somewhat poorer results - success 65-85% - were achieved by alpha-naphthyl acetic acid in concentrations 0.1 and 0.2%. The test of the significance of differences shows a significant difference at the level of 1.0% between 0.5% concentration of beta-indole acetic acid, in which rooting was 100%, and 0.1% concentration of alpha-naphthyl acetic acid, in which the percentage of rooting accounted for 65%.



Figure 3. Developed root system on an air layer (By photo M. Jovanović)

#### 4. Conclusions and discussion

The aims of the analysis of group and individual variability of beech in Serbia were the following: to understand and conserve the genetic resources of this species, to select the adequate provenances at different sites, to enhance the production and trade of seed and planting material, to explain the evolution development of the species, and to establish the live archives and seed orchards.

Grouping of the studied populations in the regions, as well as their separation, was performed using the Monmonier's algorithm of maximum differences. To visualize the results and mapping the regions of beech provenances in Serbia, GIS was used, with database included the results of this study.

Based on the study results of the biochemical and molecular analyses at the level of the selected populations and individuals of different beech provenances, it can be concluded that the adaptation ability and survival ability at the level of populations was favoured by the higher genetic variability, and at the individual level – by the higher degree of heterozygosis.

In hetero-vegetative propagation of beech test trees, the best results were achieved by the method of side grafting on overtopped, non-overtopped rootstocks, and by the method of wedge grafting, using normal buds.

In auto-vegetative propagation of beech by air layering, using growth stimulators, such as beta-indole acetic acid in concentrations 0.5 and 1.0% and beta-indole butyric acid in concentrations 0.5; 1.0 and 2.0%, the results were very good, i.e. the percentage of rooting was from 90 to 100%.

The information on the genetic variability of beech is important for the more precise study of:

- intra-population and inter-population differentiation in its range of distribution,
- adaptation ability, and
- existence and the degree of divergence of individual beech provenances at different sites.

## References

- Ertekin, M., Kırdar, E., Ayan, S. 2015. The Effects of Exposure, Elevation and Tree Age on Seed Characteristics of *Fagus orientalis* Lipsky. *South-east Eur for* 6 (1): 15-23. DOI: <http://dx.doi.org/10.15177/seefor.15-03>
- Glišić, M. 1960. Šumska semenska područja NR Srbije, Beograd
- Gömöry, D., L. Paule, R. Brus, P. Zhelev, Z. Tomović, J. Gračan 1999. Genetic differentiation and phylogeny of beech on the Balkan peninsula. *J. Evol. Biol.*, 12: 746-754.
- Isajev V., Tucović A., Mataruga M. 2000 Ključne etape u procesu proizvodnje namenskog sadnog amaterijala. Glasnik Šumarskog fakulteta 82, Šumarski fakultet Univerziteta u Beogradu. Beograd.
- Isajev V., Vukin M. Ivetić V. 2003. Prirodni semenski objekti bukve u Srbiji – osnova za unapređenje proizvodnje semena i sadnica. Šumarstvo br. 1-2. Beograd. 85-97
- Isajev V. 2005. Variability and breeding of beech in Serbia. In Monograph Beech (*Fagus moesiaca* /Domin, Maly /Czeczott.) in Serbia. Association of Forest engineers and technicians of Serbia and Forest faculty, Belgrade. 141-177.
- Ivetić, V., Isajev V., Mladenović-Drinić S., 2008. "Landscape shape interpolation" for defining spatial pattern of beech genetic diversity in Serbia. *Genetika*. Vol. 40, No. 3. Pp. 283-292
- Ivetić, V., Isajev V., Stavretović N., & Mladenović-Drinić S. 2010. Implementation of Monmonier's algorithm of maximum differences for the regionalization of forest tree populations as a basis for the selection of seed sources. *Archives of Biological Sciences*, 62 (2) 425-430.
- Ivetić V., V. Isajev, A. Nikolic, M. Krstic, D. Ristic, Kostadinovic, M. 2012. Delineation of beech provenance regions in Serbia by spatial analysis of genetic diversity. - *Genetika*, Vol 44, No. 1, 101 - 108.
- Jovanović, M. 1961. Izdvajanje semenskih sastojina - prva faza rada na oplemenjivanju i selekciji šumskog drveća, Šumarstvo 5-6, Beograd.
- Jovanović, M. 1971. Oplemenjivanje bukve (*Fagus moesiaca*/D.M./Czeczott.) u SR Srbiji. Doktorska disertacija/rukopis/. Beograd.
- Lavadinović, V., Isajev, V. 2001. Genetic potential of seed sources in Serbia. Third Balkan Scientific Conference "Study, Conservation and Utilization of Forest Resources, Proceedings, Volume II, Sofia, Bulgaria, pp. 111-118.
- Lavadinović, V., Isajev V. 2002. Genetski potencijal semenskih objekata bukve u Srbiji-osnova za oplemenjivanje vrste. Zbornik radova Instituta za šumarstvo, Tom 46-47, pp 32-40. Beograd
- Marić, B., Jovanović, M. 1961. Uputstva za izdvajanje i registraciju semenskih objekata četinara. Jugos. Savet. centar za poljop. i šumarstvo, Beograd.
- Marić, Mmo. 1962. Izdvajanje semenskih sastojina četinara u SR Srbiji, Topola 25-26, Beograd.
- Monomonnier, M.S. 1973. Maximum-difference barriers: an alternative numerical regionalization method. *Geographical Analysis*. Volume V, Nr. 3, Pp. 254-261.
- Tucović, A. 1970. Sprovođenje uzgojno meliorativnih i drugih mera u semenskim objektima - važan zadatak u šumarstvu Srbije, Savetovanje o značaju i primeni selekcije u šumskoj proizvodnji, Goč.
- Tucović, A. 1976. Značaj i uloga semenskih objekata šumskog drveća u svetlosti neposrednih zadataka planiranja i razvoja šumarstva, Poslovno udruženje drvne industrije i šumarstva, posebno izdanje, Beograd.

(Received for publication 16 October 2015; The date of publication 15 August 2016)



## Definition of *Fagus orientalis* Lipsky. dominated biotopes in Güzelcehisar, Mugada and Kızılkum region of Bartın province

Yeliz SARI NAYIM\*<sup>1</sup>

<sup>1</sup> Bartın University, Faculty of Forestry, Department of Landscape Architecture, Bartın, Turkey

### Abstract

Oriental beech makes its best spread and physical development on slopes of hills extending parallel to Black Sea shoreline in Turkey. Pure and mixed *Fagus orientalis* Lipsky. forests are particularly located northern slopes. Study area covers slopes facing to Black Sea within coastal areas of the settlements of Güzelcehisar, Mugada and Kızılkum, Bartın Province. The route formed by these settlements represents the part of Northwest Euxine Broadleaved forests of European-Siberian Region. The study area, at the same time, is located in the 'Eu-Euxine' part that is the most humid belt close to seaside. Euxine Beech forests intensely take part in this area and spread to the sea. This study was carried out in two stages. Initially abiotic and biotic components of study area were defined and data belong to them were collected and stored in a GIS geodatabase. Then, with help of the most recent satellite images and contemporary land use map, abiotic and biotic components of Beech dominated biotopes and land use properties evaluated together. In this way, spread of biotopes dominated by *Fagus orientalis* in and around Güzelcehisar, Mugada ve Kızılkum, habitat characteristics and structural changes due to land uses were determined. According to the result of study, the most intense spread of Beech communities takes place around hilly areas of Güzelcehisar where Yemişliçay formation consisting of sandstone, sheyl and limestone exists. Beech communities disappear in low elevated areas around Mugada and Kızılkum. It was determined that the most effective factors on spread of species are elevation, aspects and geologic characteristic of habitats. It was also determined that *Fagus orientalis* often forms mixed forests with *Carpinus betulus*, *Castanea sativa* and *Quercus petraea* ssp. *iberica*. And also, with field works it was determined that Beech biotopes were adversely affected by man based factors such as grazing, deforestation for agricultural use, road networks and rural settlements. Definition of Beech forests which take place in habitat classification of EU and contribute to biodiversity will be a preliminary assessment for protection and sustainable use of Euxine beech forests located in coastal areas of the Province of Bartın.

**Key words:** *Fagus orientalis* biotopes, habitat classification, Güzelcehisar, Mugada, Kızılkum

----- \* -----

### Bartın ili Güzelcehisar, Mugada ve Kızılkum bölgesinde Doğu kayınının hakim olduğu biyotopların tanımlanması

### Özet

Doğu kayını, Türkiye'de en geniş yayılışını ve en iyi gelişimini Karadeniz kıyısına paralel uzanan dağlık yamaçlarda yapmaktadır. Saf veya karışık *Fagus orientalis* Lipsky. (Doğu kayını) ormanları özellikle kuzey yamaçlarda konumlanmıştır. Çalışma alanı, Bartın ili kıyı kesiminin Güzelcehisar, Mugada ve Kızılkum bölümünde Karadeniz sahiline bakan yamaçları kapsamaktadır. Bu hat Avrupa-Sibirya Bölgesi'nin Kuzeybatı öksin yapraklı ormanlarının bulunduğu bölümü temsil etmektedir. Aynı zamanda alanın, Karadeniz'in denize yakın ve en nemli kuşağı olan 'Eu-Euxine' bölümünde yer aldığı görülmektedir. Öksin Kayın ormanları, bu kesimde yoğun olarak yer almakta ve denize kadar ulaşmaktadır. Çalışma iki aşamada yürütülmüştür. İlk aşamada alana ait abiyotik ve biyotik potansiyele ait sayısal harita katmanları, ArcGIS ortamında bir araya getirilmiştir. Daha sonra güncel uydu görüntüleri ve alan kullanım haritası aracılığıyla Kayın biyotoplarına ait abiyotik ve biyotik özellikler ile alan kullanımları bir arada değerlendirilmiştir. Bu şekilde *Fagus orientalis* Lipsky (Doğu kayını)'nın hakim olduğu biyotopların, Güzelcehisar,

\* Corresponding author / Haberleşmeden sorumlu yazar: Tel.: +90378235124; Fax.: +903782235062; E-mail: yelizsari@yahoo.com

© 2008 All rights reserved / Tüm hakları saklıdır

Mugada ve Kızılkum Bölgesinde alan içindeki dağılımı, yetişme ortamı özellikleri ve alan kullanımları sonucu oluşan değişimleri tanımlanmıştır. Araştırma sonucunda Kayın toplumlarının büyük çoğunluğunun Güzelcehisar çevresindeki volkonajenik kumtaşı, şeyl, kireçtaşı içeren Yemişliçay formasyonu üzerindeki yüksek kesimlerde yayılış gösterdiği belirlenmiştir. Mugada ve Kızılkum çevresinde yükseltinin azaldığı mekanlarda ise Kayın toplumları ortadan kaybolmaktadır. Abiyotik özelliklerden en fazla yükseklik, bakı ve jeolojik özelliklerin türün dağılımına etki ettiği görülmektedir. Arazi çalışmaları sonucunda *Fagus orientalis*'in çoğunlukla *Carpinus betulus*, *Castanea sativa* ve *Quercus petraea* ssp. *iberica* ile karışık ormanlar oluşturduğu tespit edilmiştir. Ayrıca, Kayın biyotopunun otlatma ve tarım amaçlı açmalar, ulaşım bağlantıları ve kırsal yerleşim gibi insan etkileri sonucunda olumsuz etkilendiği arazi çalışmaları ile ortaya konulmuştur. Avrupa Birliği Habitat sınıflandırmasında yer alan, biyoçeşitliliğe katkı sağlayan Kayın ekosistemlerinin araştırma alanı içinde tanımlanması, Bartın ili kıyı kesimindeki öksin kayın ormanlarının korunması ve sürdürülebilir kullanımı açısından yararlı bir ön değerlendirmeyi oluşturacağı düşünülmektedir.

**Anahtar kelimeler:** *Fagus orientalis* biyotopları, habitat sınıflandırması, Güzelcehisar, Mugada, Kızılkum

## 1. Introduction

The protection of biological diversity for today and tomorrow requires the correct analysis and interpretation of the ecological and biological relations as well as processes that take place in the ecosphere. Data regarding these relationships and processes are acquired by defining ecotopes and/or biotopes which make up the smallest units in the ecosystem (Sarı Nayim, 2010).

Biotope can be described as a geographical area that has a uniform biological environment and a uniform distribution of organisms (Dahl, 1908; Ayaşlıgil, 1997; Ayaşlıgil, 2008). Biotopes provide habitats for living communities that come together characteristically. On the other hand, interference on biotopes threatens living environment and adversely influences biodiversity. This fact makes biotope mapping that has a fundamental role in nature conservation and landscape planning process, inevitable.

Black Sea Region is an important biogeographical region. This region which needs to be studied and which has a different biotope potential, incorporates such ecosystems as various forests, pseudomaquis, meadows, grasslands, rocky areas, sand dunes which lies parallel to the Black Sea and requires protection.

Black Sea forest biotopes have a significant place in various European habitat/biotope classification systems such as Natura 2000 and CORINE Biotopes. These forest types are mentioned in European potential natural vegetation map which forms the basis of habitat classification systems. Here they are included under '*F-Mesophytic deciduous broadleaved and mixed coniferous-broadleaved forests*' topic. In this vegetation map, *Fagus orientalis* Lipsky. forests are given under F5-Beech and mixed beech forests, F6-Oriental beech subgroups (Bohn et al., 2007).

Oriental beech makes its best spread and physical development slopes of hills extending parallel to Black Sea shoreline in Turkey. The routes formed by these settlements represent the part of Northwest Euxine Broadleaved forests of European-Siberian Region (Zohary, 1973; Mayer and Aksoy, 1998; Ertekin et. al., 2015). The study area, at the same time, is located in the 'Eu-Euxine' part that is the most humid belt close to seaside. Euxine Beech forests intensely take part in this area and spread to the sea (Zohary, 1973; Yalıtık and Efe, 1996).

Mayer and Aksoy (1998) name Western Black Sea *Fagus orientalis* Lipsky. forests as silicate *Fagus orientalis* mixed forests at coline-submountain level and *Rhododendron ponticum*. Unfortunately, North Anatolian/Black Sea coast ecosystems where important *Fagus orientalis* ecosystems exist, have been negatively effected from the change in the utilization of area in the last 50 years and continues to be effected. Black Sea coastal zone is under the intense impact of agriculture, industry, energy production, mining, maritime transportation, urban development and of course tourism (European Commission, 2009).

This study aims to identify biotopes in Güzelcehisar, Mugada and Kızılkum where natural and semi-natural important *Fagus orientalis* is dominant and to map them in ArcGIS and thus, to contribute to the protection of the species and ecosystem diversity in Bartın province coastal line.

## 2. Materials and methods

The study was carried out on the coastal line of Bartın province which is located in Western Black Sea Region in Turkey. Particularly, the study area was the slopes of Güzelcehisar, Mugada and Kızılkum areas overlooking the Black Sea coast (Figure 1).

When the 10-year forest management plan of Bartın province covering 2001-2010 years is examined, it is seen that such main species as *Fagus orientalis*, *Carpinus betulus*, *Quercus* spp., *Castanea sativa*, *Tilia argentea*, *Ostrya carpinifolia*, *Pinus brutia* are dominant ecosystems in the study area (Bartın Provincial Department of Forestry, 2001).

Identification of *Fagus orientalis* biotopes in the study was carried out using the CORINE Biotope Project (European Communities, 1991). In identifying CORINE Biotopes, classification of vegetation was focused on, and those communities which could be distinguished as a result of the interaction between flora and abiotic environment were defined using ArcGIS tools ((European Communities, 1991; Oudheusden, 2005).



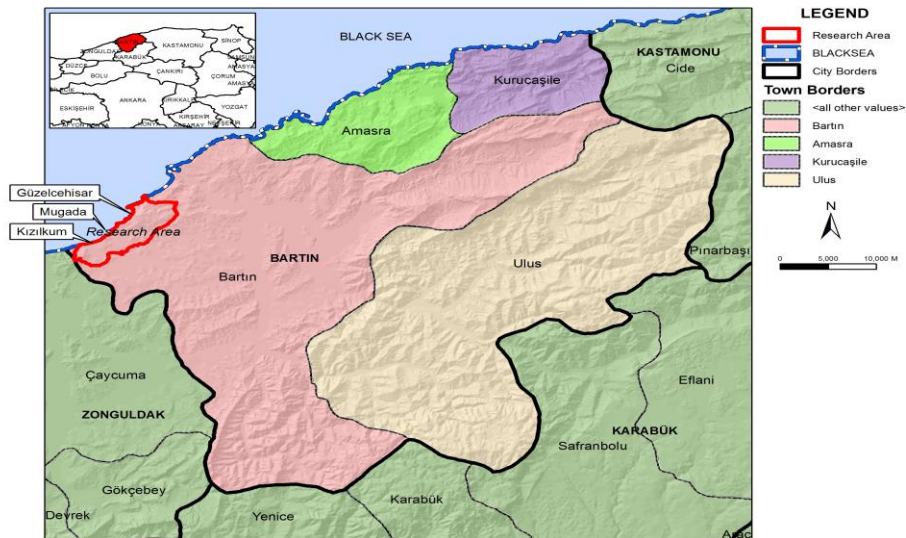

Figure 1. Location of the research area.

Initially abiotic and biotic components of study area were defined and data belong to them were collected and stored in a GIS geodatabase. Then, with help of the most recent satellite images and contemporary land use map, abiotic and biotic components of Beech dominated biotopes and land use properties evaluated together. In this way, spread of biotopes dominated by *Fagus orientalis* Lipsky. (Oriental beech) and around Güzelcehisar, Mugada and Kızılkum, habitat characteristics and structural changes due to land uses were determined..

### 3. Results

According to the results from digital maps of all the study area covering a 3665 ha area, 58% (2112 ha) is composed of forest biotopes. And of the forest communities, 55% (1160 ha) is composed of forest biotopes dominated by Beech trees. The overall expansion, floristic structure, human activities and effects are defined below.

#### 1.1. Expansion

*Fagus orientalis* expands in the mid and high mountainside slopes of the area overlooking the Black Sea just purely or together with other deciduous trees such as Oak, Chestnut, Hornbeam and Lime. When their amounts of expansion are considered, it is seen that *Fagus orientalis* and *Quercus* spp. have the largest expansion with 254 ha. and these two are followed by *Fagus orientalis* and *Castanea sativa* covering an area of 185 ha, pure *Fagus orientalis* covering 177 ha, *Fagus orientalis* and *Carpinus betulus* covering an area of 171 ha. *Fagus orientalis* combines with *Tilia argentea* at a very small area of 1.6 ha (Figure 2, Figure 3).

It was determined that the most effective factors on spread of species are elevation, aspects and geologic characteristic of habitats. When the heights they expand are examined, it is found that *Fagus orientalis* biotopes are found at 91-348 meter height.

When geology and plant cover breakdown are examined together, it is seen that the largest amount of *Fagus orientalis* biotopes that is 71% are found on Yemişliçay formation which includes volcanogenic sandstone, tuff, andesite and basalt. And the remaining 12.5% are found in Yılanlı formation which includes sandstone and dolomite limestone; and other 12.5% are found in Akveren formation which includes sandstone, shale and conglomerate.

According to the result of study, the most intense spread of Beech communities takes place around hilly areas of Güzelcehisar where Yemişliçay formation consisting of sandstone, sheyl and limestone exists. The only pure *Fagus orientalis* community in the area is found at Güzelcehisar around 279-348 meter height and on Yemişliçay formation.

Beech communities disappear in low elevated areas around Mugada and Kızılkum. The *Fagus orientalis* community is the lowest height is found around Kızılkum and at 91 meters. Around the areas close to the coast between Kızılkum and Filyos valleys such deciduous trees as *Carpinus betulus*, *Quercus* spp. and *Castanea sativa* accompany *Fagus orientalis* (Figure 2).

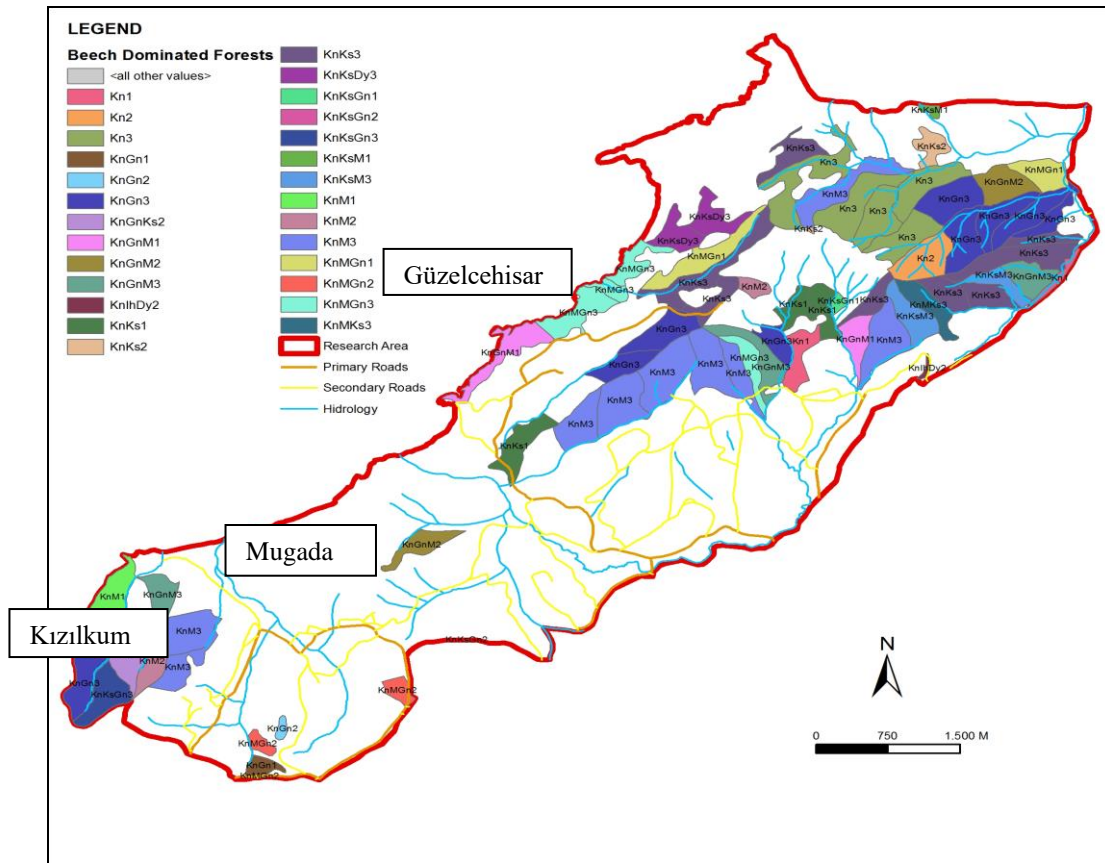

Figure 2. The distribution of the biotopes in the study area where *Fagus orientalis* is dominant.

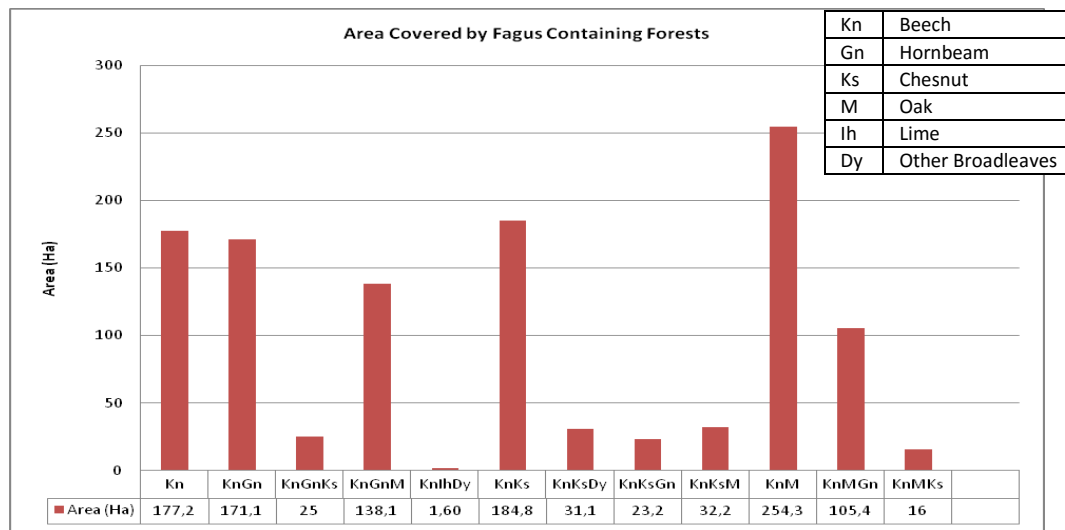

Figure 3. The distribution of the area that pure and mixed *Fagus orientalis* communities in the study area cover.

1.2. Floristic structure

It was also determined that *Fagus orientalis* often forms mixed forests with *Carpinus betulus*, *Castanea sativa* and *Quercus petraea* ssp. *iberica*.

In the shrub layer of the forest, high moisture resistant evergreen plants such as *Laurocerasus officinalis*, *Rhododendron ponticum* s.str., *Ilex colchica*, *Rubus ideaeus*, *Corylus avellana* s.str., *Vaccinium arctostaphylos* and in the herbaceous species as *Hedera colchica*, *Primula vulgaris* ssp. *sibthorpii*, *Trachystemon orientalis*, *Polystichum setiferum*, *Astragalus glycyphyllos* s.str., *Fragaria vesca*, *Dryopteris filix-mas*, *Cardamine quinquefolia*, *Hypericum calycinum*, *Phyllitis scolopendrium* are dominantly located.

Table 1. The amount of the areas that *Fagus orientalis* communities expand

Wood Type	Area (m <sup>2</sup> )	Area (ha)
Kn	1772541	177,2
KnGn	1711871	171,1
KnGnKs	249295	25
KnGnM	1381535	138,1
KnIhDy	15756	1,60
KnKs	1847827	184,8
KnKsDy	311504	31,1
KnKsGn	232777	23,2
KnKsM	321726	32,2
KnM	2543967	254,3
KnMGn	1053633	105,4
KnMKs	159645	16
<b>Toplam</b>	<b>11602077</b>	<b>1160</b>

### 1.3. Human activities and their impact

With field works it was determined that Beech biotopes were adversely affected by man based factors such as grazing, deforestation for agricultural use, road networks and rural settlements. Fertile hazelnut gardens and agriculture lands expands through the deep and slimy soil between Güzelcehisar-Kızılkum areas where there are *Fagus orientalis* forests.

## 4. Conclusions and discussion

Karabük-Yenice forests which is an important and protected area in Western Black Sea, Bolu-Yedigöller National Park and Kastamonu-Bartın Küre Mountains National Park forests are protected areas close to Bartın province and the study area. These three areas can be considered as important reserve areas best representing the Western Black Sea Euxine *Fagus orientalis* community character (Mayer and Aksoy, 1998; Ministry of Forestry and Water Affairs, 2016).

*Fagus orientalis* biotopes in Bartın province are delicate ecosystems and they should be protected. In the biotope map prepared by Sarı Nayım (2010) covering the area between İnkum and Amasra, *Fagus orientalis* ecosystems are determined as delicate biotopes in terms of the important species they consist.

The delicate *Fagus orientalis* biotopes between Güzelcehisar-Kızılkum together with other *Fagus orientalis* ecosystems in Bartın province should be connected with the aforementioned protected areas. At the same time, the main elements of landscape ecology which are almost natural corridors and step stones should be evaluated and biotope inventory towards forming new protected areas in existing empty spaces should be created.

In this study, it was seen that in steep slopes where the land is not convenient for use and in areas where transportation infrastructure is either weak or completely destroyed, natural *Fagus orientalis* ecosystems close to the coast are better protected. It can be said that the protection and management of the biological diversity in the region are related to accessibility and level of infrastructure. This should be considered as an opportunity in the coastal planning stated in the 1/25000 scale Bartın province Environmental Plan.

Defining *Fagus orientalis* ecosystems, which contribute to biodiversity and is included in the European Union Habitat Classification, within the study area will be a useful pre-assessment for the protection and sustainable use of Euxine *Fagus orientalis* forests in Bartın.

## References

- Ayaşlıgil, Y. 1997. Biyotop haritalama ve peyzaj planlama açısından önemi. Doğayı Korumada Kent ve Ekoloji Sempozyumu, 18-19 Aralık 1997 İstanbul, İTÜ Mimarlık Fakültesi: Türkiye Doğayı Koruma Vakfı, 199-208.
- Ayaşlıgil, Y. 2008. Peyzaj ekolojisi ders notları. İÜ Orman Fakültesi, Peyzaj Mimarlığı Bölümü, İstanbul.
- Bartın Provincial Department of Forestry, 2001. Bartın Orman İşletme ve Amasra Orman İşletme Şeflikleri 2001-2010 uygulama yıllarına ait orman amenajman planları. Orman Genel Müdürlüğü, Ankara.
- Bohn, U., Zazanashvili, N., Nakhutsrishvili, G. 2007. The map of the Natural Vegetation of Europe and its application in the Caucasus Ecoregion. Bulletin of the Georgian National Academy of Sciences, 175/1.
- Dahl, F. 1908. Grundsätze und grundbegriffe der biocoenotischen forschung. Zoologischer Anzeiger, T.33, 349-353.
- Ertekin, M., Kırdar, E., Ayan, S. 2015. The Effects of Exposure, Elevation and Tree Age on Seed Characteristics of *Fagus orientalis* Lipsky. *South-east Eur for* 6 (1): 15-23. DOI: <http://dx.doi.org/10.15177/see-for.15-03>

- European Communities 1991. Habitats of the European Community Corine Biotopes manual. Volume 2, Commission of the European Communities L-2920, Luxemburg, 92-826-3211-3, <http://biodiversity-chm.eea.europa.eu/information/document> [21 May 2007].
- European Commission, 2009. Natura 2000 in the Black Sea Region. European Commission, Luxembourg, ISBN 978-92-79-11585-1, 12pp. [www.ec.europa.eu/environment/nature](http://www.ec.europa.eu/environment/nature)
- Mayer, H., Aksoy, H. 1998. Türkiye ormanları. Batı Karadeniz Ormançılık Araştırma Enstitüsü, Abant İzzet Baysal Ü. Basımevi, Bolu, 975-7829-56-0.
- Ministry of Forestry and Water Affairs, 2016. General Directorate of Nature Protection and National Parks, Turkey, <http://ormansu.gov.tr> [29 June 2016]
- Oudheusden, R. 2005. The Corine biotopes projects. Department of Science, Technology and Society, Utrecht University.
- Sarı Nayim, Y. 2010. Amasra-İnkum (Bartın) arasında yer alan önemli biyotopların haritalanması, Doktora Tezi, İstanbul Üniversitesi Fen Bilimleri Enstitüsü, İstanbul.
- Yaltırık, F., Efe, A. 1996. Otsu bitkiler sistematigi. İ.Ü. Orman Fakültesi Yayını, Yayın no: 10, İstanbul, 975-484-122-9.
- Zohary, M. 1973. Geobotanical foundations of the Middle-East. Gustav Fischer Verlag, Stuttgart..

**This research was supported by the Bartın University Scientific Research Projects Commission (Project no: 2013.2.112)**

*(Received for publication 06 July 2015; The date of publication 15 August 2016)*



## Determination of physical and mechanical properties of beech (*Fagus sylvatica* L.) wood - utilization perspectives in Greece

Kamperidou VASILIKI<sup>\*1</sup>, Ioannis BARBOUTIS<sup>1</sup>

<sup>1</sup> Aristotle University of Thessaloniki, Faculty of Forestry and Natural Environment, Laboratory of Wood products Technology, 54124, Thessaloniki, Greece

### Abstract

Beech wood is widely available across Europe, and one of the most important commercial hardwood species in European, as well as Greek, forestry. The scope of this research was to enlighten the production of Greek beech forests, the conditions of wood sawmills and the range of utilization possibilities of beech wood, by determining mechanical properties such as, bending strength, modulus of elasticity, radial and tangential hardness of beech wood and compare them with the respective values of previous researches results. Indicatively, the production of beech wood referring to lumber, materials for wood based panels and fuelwood in Greece the year of 2011 was 51.297, 7.472 and 219.653 m<sup>3</sup>, respectively. Beech wood is classified as a medium density hardwood and it is a material of low price and low cost of machining. There is a big range of applications of this species with the most common application to be flooring, furniture, brushes, blocks, handles, veneers and woodenware. In Greece beech lumber was intended mainly for the construction of furniture as steamed wood in the apparent parts of the structure, as well as the upholstered furniture frames, boxes and pallets, as not steamed wood. Generally, the quality of the sawn beech logs in Greece is not quite satisfying, a fact proved by the low percentage of the produced beech lumber of the quality class A (approximately 10%). The financial crisis of the last years decreased the demand of wood and wood products in the market and as a result, many of the wood and furniture industries in Greece have been closed. Nowadays, there is not enough demand of beech round wood and annually large quantities of this material conclude to be used plainly as fuelwood, reducing the added value of beech wood. In a period of such an economical crisis as the current one, the use of domestic beech wood, which is a material of good price, of low machining cost, while parallel is characterized by satisfying mechanical and physical properties, could be increased and its utilization possibilities could be extended in a big range of applications, as solid wood or glued products.

**Key words:** beech, bending, hardness, mechanical strength, MOE

### 1. Introduction

Beech wood is a species that grows at an altitude of 500 m. up to 1800 m. In Greece beech is found mainly in the northern and central part of the mainland. It appears in the mountains of the northern border in north central and north eastern Greece, in the mountains of Eastern Central Greece, Holomontas in Halkidiki and the Mountain of Pindos. It dominates in the lowland, hilly and semi-mountainous zone and displays high competitiveness, forming extensive forests, pure or mixed with other hardwood and softwood species (Strid and Kit Tan, 1997).

The most famous tree of this species history was that of beech oracle of Dodoni from which the priests took the oracles interpreting rustling in combination with other sounds in their environment, although there is still a small doubt if that tree was indeed beech or oak tree. In some areas where the beech was not in abundance, prevailed to be called as "beech oak" or a kind of "oak" and generally, in the past there was a confusion over the name of beech and oak. Both 'oak' and 'beech' are 'fruit-bearing trees, offering food source for animals, so this confusion seems quite conceivable. Therefore, the Latin got the word "*Fagus*" (which word was used as the botanical name of genus of beech tree) from the Greek word "Φηγός" (phegos), with a ground sense of "edible" and is connected with the root of Greek word "Φάγειν" (phagein) meaning "to eat".

\* Corresponding author / Haberleşmeden sorumlu yazar: Tel.: +302310998845; Fax.: +302310998883; E-mail: vkamperi@for.auth.gr

It is classified as a medium density hardwood and thus, it is quite heavy (specific gravity of 0.75), hard, strong, odorless, of high resistance to impact strength forces and fine texture, available in large dimensions, which cannot usually be achieved with other species and additionally, is a material of low price and low cost of machining. Its heartwood does not normally differ from the sapwood part, but in many logs appears a coloration of the core, which is known as red heartwood of beech wood. Beech wood can be planed, coloured, polished and glued satisfactorily and bent extremely well even in very small radii. Also, the seeds of beech are rich in starch and oily substances, and are food for animals (pigs etc.). Important is also the use of its oil in the pharmaceutical as expectorant bacteriostatic, obtained by dry distillation of beech wood (Molnar et al., 2001).

Some of the most common applications are in flooring, furniture, brushes, blocks, handles, veneers, carvings and other woodworks. It is suitable for furniture construction that requires turning process. In Greece beech lumber was traditionally intended mainly for the construction of furniture, as the most basic species, in the obvious parts of the structure as steamed wood, as well as in the upholstered furniture frames, boxes and pallets, as not steamed wood, as the most basic wood species together with populus wood. It can be used also as fuel, since it produces excellent charcoal (Molnar et al., 2001).

The history of sawmills in Greece dates back to 1836 when it was founded the first saw which was working with water, which was the main method of sawing until 1950. The first modern mechanical mill, powered by steam, was founded by the University of Thessaloniki in Pertouli University Forest in 1936, followed by the establishing of four state sawmills in 1938 and 1939. In the decade of 1950 two more state sawmills were founded and since then the development of the sawn wood industry was great (Philippou, 1981a). Philippou (1981b) refer that two sawmills in Greece that produce beech wood recorded a recovery percentage of logs in lumber, relative to the logs diameter, 54.5% and 55.2%.

After a survey that took into account the market needs in Greece and the most common uses of sawn beech wood led the state sawmill of Litohoro to the production of lumber in certain combinations of dimensions: Depending on the length of the boards, they are classified into 3 categories:

- Category A: Length from 1.8 meters and over.
- Category B: Length from 1 meter to 1.7 meters.
- Category C: Length from 0.5 to 0.9 meter.

While depending on the existing defects, the lumber is classified into three quality classes: A, B and C. The defects that play decisive role in the classification of wood quality are: the size and number of knots, size of false heartwood, length and width of cracks of the edges, fissures, missing pieces from the processing and non-uniform texture (FSP, 1978). For the machining of timber numerous small sawmills were used, while in some of them there were also steaming equipment. These industries were using in great extent domestic wood and only a small amount of imported timber.

Generally, the quality of the sawn beech logs in Greece was not quite satisfying, a fact proved by the low percentage of the produced beech lumber of the quality class A, which ranged approximately to 10%. The quality classification of the sawn beech coming from sawmills in Greece is not based in official international standards, but each manufacturer establishes and follows their own criteria, which comply with the consumer's requirements and they show confidence on them (FSP, 1978). The state sawmill of Litohoro region (North Greece) was the largest one of the country in the production of sawn beech wood, recording up to 16.000 m<sup>3</sup> of round beech wood in the year of 1977 with a recovery percentage of this amounts in lumber up to 60%, of which the percentage of 9% was classified in A quality class, while the year of 1978 it processed 11037 m<sup>3</sup> of beech round wood with a recovery percentage of this amounts in lumber up to 64%, of which the 9% was again classified in A quality class (Prefecture of Pieria, Forest Department, 1979). The specific sawmill occupied 12 water reservoirs for the storage of round wood (Figure 1), for the rest of wood amounts the method of water spraying was used for its protection and preservation and also, this sawmill covered an area of 167,000 m<sup>2</sup>. Generally, the region of Pieria Prefecture covers an area of 1548000 acres, while the 73996 of these acres are covered with beech species, which corresponds to 32.25% of the whole area and as it is mentioned before about the whole country, this species covers the largest area between the other indigenous species (Prefecture of Pieria, Forest Department, 1979). The 97% of produced lumber of excellent quality was destined to be steamed using the 12 steaming ovens of the plant and then stacked and left to dry naturally and gradually under the protection of shelters. Generally, steaming process makes beech wood to acquire an infrared staining (darker color) and additionally, makes it easier to be processed and properly dried. Additionally, steaming prepares wood to be processed for the construction of curved parts and contributes to the extinction of live microorganisms in wood (Voulgaridis and Tsoumis, 1982). Litohoro plant all these years was absorbing almost the entire round beech wood production amounts coming from the forest complexes that were exploited through direct labor by the Forest Service of Larissa, Aridaia and Pieria regions. The products of Litohoro plant were exclusively channeled in the market of Greece, they were known for their high and stable quality and those years these materials used to achieve very high prices, exceeding the production costs appreciably and leaving a high gain to the sawmill (FSP, 1978). Unfortunately, this sawmill was one of the numerous sawmills that stopped functioning due to the financial crisis almost five years ago.

In 1982 the actual number of sawmills in Greece was 642, of which 252 processed around 100-1000 m<sup>3</sup> of round timber and 303 were of 1000-5000 m<sup>3</sup> capacity in round timber, while all together processed a total of 567461 m<sup>3</sup>

round wood based mainly on Greek species. Only the amount of 72872 m<sup>3</sup> was covered by imported round wood. Approximately the 40% of the Greek sawmills, referring to the number of them, as well as their production and total capacity of them, were located in Macedonia region, where the massive productive forests of the country are situated (Kavouras, 1985).



Figure 1. Pond-stored beech logs and steamed lumber in Litohoro sawmill

With the exception of a very small number of sawmills that have modern equipment, the Greek sawmills generally have old machinery, do not have furnaces for artificial drying of timber, facilities for natural drying and facilities for the protection of wood from the effects of weather conditions. Very few sawmills are equipped with facilities of steaming of timber (beech) or are equipped with facilities for further working out of timber (parquet, pallets, doors, furniture etc.) (Philippou, 1981a). Some of the main problems that wood industry in Greece faces are the lack of raw material, poor employment and exploitation of the machinery, high production costs, quite poor quality of products and weakness to promote and dispose the produced products (Philippou, 1981a). To the low quality of Greek sawn wood, contributed the poor quality of domestic raw materials, which was further deteriorated due to the poor harvesting and trafficking methods in the distances from the forest to the factory. As a result of that, the timber becomes available at lower prices in order to face the acute competition against the imported qualitative sawn timber (Philippou, 1981a). A large percentage of beech wood and its high value become lost in the circuit of activities of Logging-Processing-Use of wood, because of the poor organization and nonproper undertake of these activities, as well as non-adequate and proper utilizing of the currently established scientific knowledge and existing technology in the exploitation of wood.

The previous decades in Greece, an increase in the production of beech round wood and a decrease in fuel wood were observed, attributed partly to the gradual improvement of forest quality that had taken place (Philippou, 1981a). Despite this wood production increase, our country remained to a large extent a country based in imports, because our needs in wood could not be covered by the domestic production amounts. The financial crisis of the last years strongly decreased the demand of wood and wood products in the market and as a result many of the wood and furniture industries in Greece and especially the industries of larger capacity have been closed.

Therefore, nowadays there is not enough demand of beech round wood and annually large quantities of this material conclude to be used plainly as fuel wood, reducing the added value of beech wood. Nevertheless, in a period of an economical crisis such as the current one, the demand of low cost construction materials such as wood, is expected to be increased, compared to other building construction materials. Especially the use of domestic beech wood, which is a material of good price, that requires low cost to be machined, while at the same time is characterized by satisfying mechanical and physical properties, could be increased and its utilization possibilities could be extended in a big range of applications, as solid wood or glued products.

Instead of large wood industries that face more difficulties in their survival through this economical crisis, several smaller local enterprises could be established, in order to cover the needs of the market in qualitative wood of affordable price, especially in Greece which is a country deficit in wood quantities and base mainly on imports. Finally, as our study showed, the wood industries that adopted an orientation in commerce based on exports, managed to survive and maintain their profits and regular function inside these difficult economical conditions and this example could be characterized as one of the proper utilization tactics of beech wood in Greece. Indicatively, one of the wood industries of small size processes around 2000 m<sup>3</sup> of beech logs that have been previously qualitatively selected, presenting a lumber recovery percentage of 45% in qualitative (quality class A) lumber, the whole of which is destined for exports, and a percentage of 20% of B and C quality class lumber, which is channeled mainly in domestic market. The length of lumber pieces that this industry produces is between 2.10-3 m and the thickness mainly 25, 50 and 80 cm. He has been implementing exports since 8 years before and the only difficulty that his business faced came from the capital controls of the last months in the frame of this financial crisis in the country (Tzevelekos, 2015).

Several research works have been implemented so far on the mechanical properties of beech wood, some of whom are summarized in the following. Guntekin et al. (2014) investigated the bending properties of beech wood

(*Fagus orientalis*), while an attempt was made to predict them using stress - wave method and compare them with static bending tests. Skarvelis and Mantanis (2013) examined the physical and mechanical properties of two beech species (*Fagus sylvatica* L. and *Fagus orientalis* Lipsky) on samples originating from four different natural forests located in the central, northwest and northeast Greece and dry density, shrinkage (axial, radial, tangential), Janka hardness, static bending, longitudinal and cross-sectional compression, shear, cleavage and impact strength were investigated. Voulgaridis and Tsoumis (1982) determined mechanical properties of beech wood (*Fagus sylvatica* L.) such as Modulus of Rupture, Elasticity of wood, compression, hardness and toughness of wood, revealing the satisfying mechanical performance of this species. Lo Monaco et al. (2015) used two aged coppices of beech of Italian origin and analyzed several physical and mechanical properties, such as dry and basic density, radial, tangential and volumetric shrinkage, axial compression strength, static bending strength and Brinell hardness. Barboutis and Vasileiou (2013) studied the effects of the PVAc and PU adhesives and finger length (4.5 mm, 6.5 mm and 9.0 mm) on bending strength of finger-jointed steamed and unsteamed beech wood (*Fagus sylvatica*) and also examined some basic mechanical properties of solid beech wood.

## 2. Materials and methods

Beech wood (*Fagus sylvatica* L.) used in this research was obtained from a local wood industry in Pindos region (Central Greece) and it has been naturally desiccated for 8 months. The boards of beech wood were cut parallel to grain and were placed into a conditioned room at  $20 \pm 2^\circ\text{C}$  temperature and  $60 \pm 5\%$  relative humidity and were allowed there to attain a nominal equilibrium moisture content (EMC) of 9.32%. The mean density (oven-dry mass/volume, measured at 9.32% moisture content) of wood was found to be  $0.722 \text{ g/cm}^3$ .

These boards were cut in final cross section dimensions for the measurement of mechanical properties, according to the respective standards (Bending Strength-Modulus of Elasticity: ISO 3133:1975, Hardness (Janka): ISO 3350:1975). For each property test 10 replicate specimens were prepared, except for the hardness test where 15 replicate specimens were used. Specimens were weighed before the tests, dried in the oven at  $103 \pm 2^\circ\text{C}$  for 24 hours and reweighed in order to estimate the mean moisture content of the specimens during the tests.

Bending tests were carried out on a universal testing machine (SHIMADZU UH- 300kNA), and the rate of crosshead-movement was adjusted at 5 mm/min, so that the maximum load was reached within  $1.5 \pm 0.5$  min throughout the test. The loading continued until a break of the specimen occurred. Tests of hardness in tangential and radial direction of wood specimens were also accomplished on an Amsler Universal Wood Testing machine, adjusting the respective ancillary equipment for this test on the machine.

## 3. Results

In Table 1, several physical and mechanical properties of beech wood were derived from the bibliography and this research work and are all presented, in order to be easily compared and measurement units were converted when necessary.

The results (Table 1) revealed that, the values of physical and mechanical properties of beech wood coming from the specific research are quite similar to those of the literature. More specifically, beech wood of Greek origin presented quite higher density, compared to other researches, which explains the quite higher values of the most mechanical properties. These small differences between the mechanical properties values of beech wood of different origins normally emerge and they could be attributed to each tree quality (genetic background), the environment where it develops, as well as the age and several other factors. Generally, this satisfying mechanical behavior of beech wood in the specific research increases even more the utilization possibilities of this species in Greece. These qualitative characteristics suggest more profitable use of this species than fuel wood and its mechanical properties make this material very attractive for industrial applications.



Table 1. Physical and mechanical properties of beech wood derived from this study (first column) and from the literature

Property	This experiments results	Voulgaridis and Tsoumis, 1982	Skarvelis and Mantanis, 2013	Lo Monaco et al. 2015	Cividini 1969	Barboutis and Vasileiou, 2013	Bektas et al. 2002	Pöhler et al.2006	Molnar et al. 2001
Basic density g/cm <sup>3</sup>	0.722 (0.024)*	-	0.600-0.660	0.585-0.560	0.669	0.605 (0.052)	0.658-0.716	0.695	-
MOR (N/mm <sup>2</sup> )	119.547 (13.671)	104.4 (9.4)	105.49 (16.6)	100.9-108.4	118	108.71 (5.77)	1204 kg cm-2	127	-
(MOE) (N/mm <sup>2</sup> )	13419.826 (995.074)	(kp/m <sup>2</sup> ) 102732 (17199)	-	-	-	11163.8 (1246.6)			-
Compression parallel to grain (N/mm <sup>2</sup> )	-	490 (52) (kp/m <sup>2</sup> )	55.43 (4.5)	54.7-54.4	61	-	606 kgcm-2,		63.6
Hardness axial	-	(kp/m <sup>2</sup> ) 770 (117)	-	-	-	-	-		
Hardness radial	(kN) 5.945 (0.272)	(kp/m <sup>2</sup> ) 570 (93)	(N/mm <sup>2</sup> ) 48.54 (12.4)	-	-	-	-	(N/mm <sup>2</sup> ) Brinell 24.46	
Hardness tangential	(kN) 5.961 (0.313)	(kp/m <sup>2</sup> ) 502 (111)	(N/mm <sup>2</sup> ) 48.54 (12.4)	(N/mm <sup>2</sup> ) Brinell 29.8-27.7	-	-		(N/mm <sup>2</sup> ) Brinell 26.87	(N/mm <sup>2</sup> ) Brinell 25.1
Toughness (kpm/cm <sup>3</sup> )	-	0.44 (0.19)	-	-	-	-	-		

\*Numbers in parentheses represent the standard deviation

#### 4. Conclusions and discussion

The scope of this research was to focus on the production of Greek beech forests, the conditions of wood sawmills and the range of utilization possibilities of beech wood, by determining mechanical properties such as, bending strength, modulus of elasticity, radial and tangential hardness of beech wood and compare them with the respective values of previous researches results. Beech wood (*Fagus* species) is a species widely available across Europe, one of the most important commercial hardwood species in European and also in the World (Ertekin et. al., 2015), as well as Greek forestry and is classified as a medium density hardwood of low price, low cost of machining and is characterized by satisfying mechanical and physical properties. In Greece, beech lumber was intended mainly for the construction of furniture as steamed wood in the apparent parts of the structure, as well as the upholstered furniture frames, boxes and pallets, as not steamed wood. Generally, the quality of the sawn beech logs in Greece is not quite satisfying, a fact proved by the low percentage of the produced beech lumber of the quality class A (approximately 10%).

The financial crisis of the last years decreased the demand of wood and wood products in the market and as a result, many of the wood and furniture industries in Greece have been closed. Nowadays, there is not enough demand of beech round wood and annually large quantities of this material conclude to be used plainly as fuelwood, reducing the added value of beech wood. Beech wood shows interesting qualitative characteristics, suggesting a more profitable use than fuelwood and its mechanical properties make this material theoretically very attractive for industrial applications.

The use of beech wood could be increased and its utilization possibilities could be extended in a big range of applications, as solid wood or glued products. Generally, in the future the wood industries should focus on wood exports, including solid wood or glued wood products. Especially the construction of glued products offers the opportunity to exploit material of low quality, as is the quality of the largest percentage of Greek timber, through the process of the defects removal from the lumber, contributing in that way in the construction of clear products of high added value..

#### References

- Barboutis, I., Vasileiou, V. 2013. Strength of Finger-jointed Beech Wood (*Fagus sylvatica*) constructed with small finger lengths and bonded with PU and PVAC Adhesives. International Conference “Wood Science and Engineering in the Third Millennium” – ICWSE 2013
- Bektas, I., Guler, G., Basturk, M.A. 2002. Principal Mechanical Properties of Eastern Beech Wood (*Fagus orientalis* Lipsky) Naturally Grown in Andırın Northeastern Mediterranean Region of Turkey Turk J Agric For 26 (2002) 147-154

- Cividini, R. 1967. Study of the characteristics of parquet woods and their evaluation. *Contributi scientifico pratici*, Istituto Nazionale del legno, CNR, Roma, Italy, vol. 8, pp. 1-42.
- Ertekin, M., Kırdar, E., Ayan, S. 2015. The effects of exposure, elevation and tree age on seed characteristics of *Fagus orientalis* Lipsky. *South-east Eur for* 6 (1): 15-23. DOI: <http://dx.doi.org/10.15177/seefor.15-03>
- Forest Service of Pieria, 1978. State Wood Industry of Litothoro. Factsheet of 1978.
- Guntekin, E., Ozkan, S., Yilmaz, T. 2014. Prediction of Bending Properties for Beech lumber using stress wave method. *Maderas. Ciencia y tecnología* 16(1): 93-98, 2014.
- Kavouras, P. 1985. Forest Industries – A study of the strategy for the development of the Greek Forestry and Wood Science. Ministry of Agriculture, Forest Research Institute of Thessaloniki, Precursor Announcement of March-13-14-15 (1985).
- Lo Monaco, A., Calienno, L., Pelosi, C., Balletti, F., Agresti, G., Picchio, R. 2015. Technical properties of beech wood from aged coppices in central Italy. *iForest* (2015) 8: 82-88.
- Molnar, S., Nemeth, R., Feher, S., Tolvaj, L., Papp, G., Varga, F. 2001. Technical and technological properties of Hungarian beech wood consider the red heart. *Wood Research* 46 (1): 21-30.
- MPREE (Ministry of Productive Reconstruction, Environment and Energy), 2014. Activities Report of Forest Service in Greece of the year of 2011. Athens, July 2014.
- Prefecture of Pieria, Forest Department, 1979. The forested Pieria. Factsheet of Forest Department of Pieria. Katerini, March 1979.
- Philippou, I. 1981a. Wood industry in Greece. *Anatypo*. Proceedings of International Symposium "Mechanization in forestry enjoyment." Thessaloniki 23-29 August 1981.
- Philippou, I. 1981b. A study of sawing conditions on eight sawmills in Greece. *Scientific annals of the school of Agriculture and Forestry*. Vol.24, No.3.
- Pohler, E., Klingner, R., Kunniger, T., 2006. Beech (*Fagus sylvatica* L.) - Technological properties, adhesion behaviour and colour stability with and without coatings of the red heartwood. *Ann. For. Sci.* 63 (2006) 129–137
- Skarvelis, M., Mantanis, G. I. 2013. Physical and Mechanical properties of Beech Wood harvested in the Greek public forests. *Wood Research*, 58 (1).
- Strid, A., Kit Tan, 1997. *Flora Hellenica*. Vol.1, Koeltz, Konigstein.
- Tzevelekos, A. E. 2015. Tzevelekos A.E. – A standard unit in wood processing. ([http://www.tzevelekossa.gr/index.php?option=com\\_content&view=article&id=9&Itemid=](http://www.tzevelekossa.gr/index.php?option=com_content&view=article&id=9&Itemid=))
- Voulgaridis, E., Tsoumis, G. 1982. Effect of steaming on the properties of Beech wood. *Scientific annals of the school of Forestry and Natural Environment*. Vol.KE, No.5.

(Received for publication 28 August 2015; The date of publication 15 August 2016)



## The importance of beech seed sources in Serbia for enhancement of seed and seedling production

Vera LAVADINOVIĆ <sup>\*1</sup>, Vasilije ISAJEV <sup>1</sup>, Ljubinko RAKONJAC <sup>1</sup>, Aleksandar LUČIĆ <sup>1</sup>

<sup>1</sup> Institute for Forestry, 11030 Belgrade, Serbia

### Abstract

In Serbia, The Balkan beech, *Fagus moesiaca* (Domin, Maly) Czeczott is one of the most important and commercial broadleaf tree species. Beech is mainly regenerated naturally; however, for different silvicultural demands and afforestation needs, it is necessary to provide good quality planting material. To supply good quality seed and as a form of beech gene pool conservation in situ, 19 seed stands of this species were designated in Serbia. Selected seed stands are distributed throughout all types of beech communities in Serbia. This paper presents their characteristic, significance and direction of further beech seed and seedling production.

**Key words:** beech, seed stands, genetically potential, *Fagus moesiaca*

### 1. Introduction

One of the most abundant and economically important hardwood genera in northern hemisphere temperate forests is *Fagus*. The species in the Genus *Fagus* –*Fagus sylvatica* L., *Fagus moesiaca* (Domin, Maly) Czec Zott and *Fagus orientalis* Lipski are among the most widely distributed and economical the most important broadleaf species in Eurasia (Ertekin et. al., 2015). Also, in Serbia beech *Fagus moesiaca* is one of the most commercial broadleaf species.

Beech is mainly regenerated naturally, however for different silvicultural demands and afforestation it is necessary to provide the good quality planting material. To supply good quality seed and as a form of beech gene pool conservation in situ, 19 seed stands of this species were designated in Serbia.

These papers are the main guidelines for the assessment, designation and management of beech seed sources. As this activity is most significant in the organisation of modern seed and seedling production, it must be studied in detail from the aspect of specificities of individual stands and provenances, so that practical instructions are provided for the implementation of selection in the designation and management of seed sources. The number of designated seed stands depends on beech significance in forestry and genetic differentiation of the populations. The beech with a wide range of distribution, which is also disjunctive, has a greater genetic differentiation of populations which occur spontaneously at various sites. In such cases, a greater number of seed stands are necessary, especially for the beech whose variability has not been sufficiently studied in Serbia. This paper presents their characteristic, significance and direction of further beech seed and seedling production.

### 2. Materials and methods

Beech is distinguished by high individual and group variability, of a major number of its morphological and genetic-physiological characteristics (Isajev, 2007; Lavadinović and Isajev 2001; 2002). This requires a multidisciplinary and complex approach in further work on the research and the directed use of group and individual variability. The protection and directed use of the most valuable beech genetic resources is realised mostly by the selection of the best beech natural populations and by the revision of the existing and the selection of the new seed stands, groups and individual trees

Parallel with the mass selection, individual selection was also undertaken, for the initial material in the application of synthetic methods of breeding. In this aim, on 17 sites in the central region of Serbia, 74 «test» trees were selected, of which 1 is in the sub-alliance *Fagenion moesiacae submontanum* Jov., 1976, 40 in the sub-alliance *Fagenion moesiacae montanum* Jov. 1976, and 33 trees are in the sub-alliance *Abieti-Fagenion moesiacae* Jov., 1976.

\* Corresponding author / Haberleşmeden sorumlu yazar: Tel.: +381113553355; Fax.: ++381112545969; E-mail: mail:veralava@eunet.rs

The test trees were evaluated only based on their phenotype characteristics. The more precise insight into their genotype was started in the actual research by early tests on the generative progeny. In this way it will be checked if really the best specimens of this species in Serbia have been selected.

### 3. Results

Selected seed stands are distributed through all types of beech communities in Serbia. Spatial distribution of beech seed stands in Serbia (Figure 1).

Group variability of beech in Serbia was studied in detail by mass selection. Seed stands were designated and the quality of phenotype characteristics of trees was evaluated and studied (Glišić, 1960; Jovanović, 1961; 1971; Marić and Jovanović, 1961; Marić, 1962; Tucović, 1970; 1976; Isajev *et al.*, 2000; 2003). Based on the method of simple mass selection, 19 beech seed stands were selected, total area 137.57 ha (Table 1). Table 1 presents seed sources of beech according to the data of the Ministry of Agriculture and Forestry of the Republic of Serbia. The number of beech seed stands has been determined based on the calculation of actual demands: nursery production resulting from the planned scope of all aspects of afforestation, reclamation, establishment of special-purpose plantations for a five-year period at least, capacity and conditions of storage and finally export demands. Each seed stand requires the organization and implementation of: 1) short-term and 2) long-term activities which imply the planning of the adequate structure of personnel, equipment and material.

Table 1. Seed sources of beech according to the data of the Ministry of Agriculture and Forestry of the Republic of Serbia

Species	Location of Seed Stand	Number of Seed Stands	Area (ha)
<i>Fagus sylvatica</i>	WESTERN SERBIA	5	29,24
<i>Fagus moesiaca</i> , <i>Abies alba</i>	CENTRAL SERBIA	4	49,16
<i>Fagus moesiaca</i>	EASTERN SERBIA	9	59,50
TOTAL AREA OF BEACH SEED STANDS			137,57

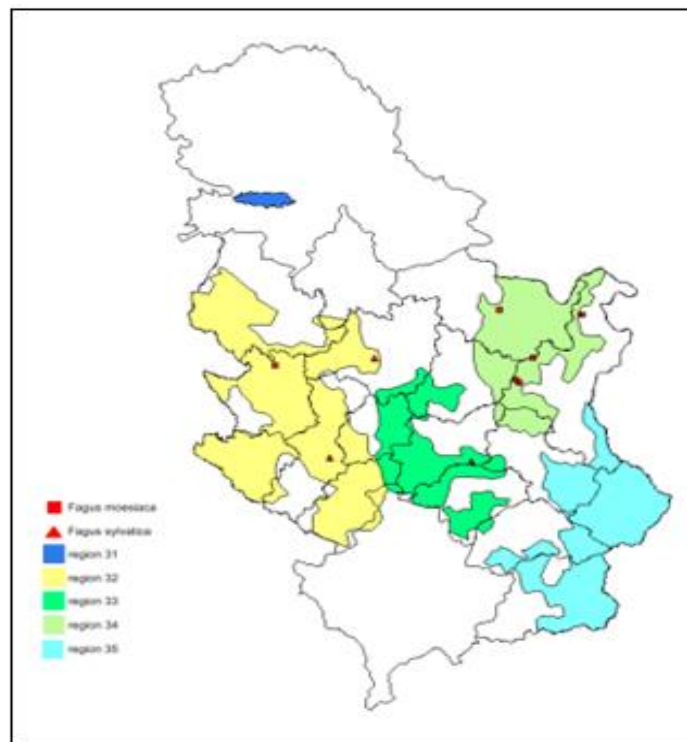

Figure 1. Spatial distribution of beech seed stands in Serbia

In planting beech stock production and trade, advantage is given to seedlings produced from the seed provenances which are, based on site characteristics, similar to those which are planned for afforestation or establishment of specific-purpose plantations. In Serbia, forest nurseries production is usually oriented to: (a) production of seedlings for the afforestation and (or) reclamation programme, (b) for the open, domestic market, i.e. for the unknown buyer, and (c) for export (Table 2).

Table 2. Beech seedling production in PE “SERBIASUME” in Serbia, in the period 2007-2012

YEAR	2008	2009	2010	2011	2012
Number of seedlings					
Produced	171000	0	199000	120000	0
Planted	158000	0	148000	110000	0

Planted productions of beech seedling in the period 2005 – 2015 are: for states forests - 5.641.599; for private forests-3.925.400, total - 9.566.999

The spatial pattern of the seed stand localities reflects almost completely the coenological, ecological and population diversity of beech in Serbia. Based on the above, it can be expected that the collected seeds and the produced planting material will encompass the genetic potential of beech in Serbia. In the designated seed sources average yield is about 10 tons of seed of beech/annual, which is the initial nursery stock for the production of about 5 million quality seedlings for domestic and foreign market.

Our previous experience, gained by the beechnut collection and trade, indicates that the best results are achieved when its collection, processing and trade are organised at the local level.

In each beech seed stand the following is organised and executed:

- 1) short-term and
- 2) long-term activities, which include also the planning of the adequate structure of personnel, equipment and material.

The immediate tasks of short-term activities are:

- removal of inferior trees around and in seed stands;
- candidature, quality evaluation and marking of seed trees;
- recording the abundance of flowering and yield;
- stimulation of seed yield by thinning and fertilising;
- protection of seed stands against pests and diseases;
- professional control of harvesting and health of fruits and seeds;
- control of seed quality pursuant to the regulated norms.

Long-term activities which run simultaneous with the use of the registered seed stands include:

- analyses of individual variability;
- analyses of generative system of propagation;
- criteria for the selection of seed trees;
- method of mass and individual selection;
- the study of the effect of the seed stand size on seed quality;
- categorisation of seeds depending on the quality of parent trees;
- experimental zoning of seed use by progeny tests.

The utilization of the genetic potential of seed sources is directed through the organized seed production.

Seed bearing frequency is every three to five years.

#### 4. Conclusions and discussion

The orientation to desired properties of seeds and nursery stock for the afforestation programmes requires the abandoning of the technology of seed and nursery stock production at the species level, because their quality is difficult to guarantee. Beech seed and seedling production is organised at the level of provenance, i.e. seed stands. The revision of the existing seed stands and the candidacy of the new seed stands are the activities of permanent character, one of the primary and priority tasks of forestry profession. These are synchronised with the work of forest estates and scientific institutions, because while some stands become too old and are destroyed by unfavourable climate, storms or insects, diseases and anthropogenic factors, some new young stands which satisfy the prescribed criteria should be given the status of seed sources. The number of seed stands should be determined based on the calculation of actual demands: nursery production resulting from the planned scope of all aspects of afforestation, reclamation, establishment of

special-purpose plantations for a five-year period at least, capacity and conditions of storage and finally export demands.

Each seed stand requires the organisation and implementation of: 1) short-term and 2) long-term activities which imply the planning of the adequate structure of personnel, equipment and material.

## References

- Ertekin, M., Kırdar, E., Ayan, S. 2015. The Effects of Exposure, Elevation and Tree Age on Seed Characteristics of *Fagus orientalis* Lipsky. *South-east Eur for* 6 (1): 15-23. DOI: <http://dx.doi.org/10.15177/see-for.15-03>
- Glišić, M. 1960. Šumska semenska područja NR Srbije, Beograd
- Gömöry, D., L. Paule, R. Brus, P. Zhelev, Z. Tomović, J. Gračan, 1999. Genetic differentiation and phylogeny of beech on the Balkan peninsula. *J. Evol. Biol.*, 12: 746-754.
- Isajev, V., Tucović A., Mataruga M. 2000. Ključne etape u procesu proizvodnje namenskog sadnog materijala. Glasnik Šumarskog fakulteta 82, Šumarski fakultet Univerziteta u Beogradu. Beograd.
- Isajev, V., Vukin M. Ivetić V. 2003. Prirodni semenski objekti bukve u Srbiji – osnova za unapređenje proizvodnje semena i sadnica. Šumarstvo br. 1-2. Beograd. 85-97
- Isajev, V. 2007. Variability and breeding of beech in Serbia. In Monograph Beech (*Fagus moesiaca* /Domin, Mally /Czeczott.) in Serbia. Association of Forest engineers and technicians of Serbia and Forest faculty, Belgrade. 141-177.
- Jovanović, M. 1961. Izdvajanje semenskih sastojina - prva faza rada na oplemenjivanju i selekciji šumskog drveća, Šumarstvo 5-6, Beograd.
- Jovanović, M. 1971. Oplemenjivanje bukve (*Fagus moesiaca*/D.M./Czeczott.) u SR Srbiji. Doktorska disertacija/rukopis/. Beograd.
- Lavadinović, V., Isajev, V. 2001. Genetic potential of seed sources in Serbia. 3rd Balkan Scientific Conference "Study, Conservation and Utilisation of Forest Resources, Proceedings, Volume II, Sofia, Bulgaria, pp. 111-118.
- Lavadinović, V., Isajev V. 2002. Genetski potencijal semenskih objekata bukve u Srbiji-osnova za oplemenjivanje vrste. Zbornik radova Instituta za šumarstvo, Tom 46-47, pp 32-40. Beograd
- Marić, B., Jovanović, M. 1961. Uputstva za izdvajanje i registraciju semenskih objekata četinarara. Jugos. Savet. centar za poljop. i šumarstvo, Beograd.
- Marić, M. 1962. Izdvajanje semenskih sastojina četinarara u SR Srbiji, Topola 25-26, Beograd.
- Tucović, A. 1970. Sprovodjenje uzgojno meliorativnih i drugih mera u semenskim objektima - važan zadatak u šumarstvu Srbije, Savetovanje o značaju i primeni selekcije u šumskoj proizvodnji, Goč.
- Tucović, A. 1976. Značaj i uloga semenskih objekata šumskog drveća u svetlosti neposrednih zadataka planiranja i razvoja šumarstva, Poslovno udruženje drvne industrije i šumarstva, posebno izdanje, Beograd.

(Received for publication 16 October 2015; The date of publication 15 August 2016)



## The survey of regeneration diversity in managed and unmanaged beech stands of north forests of Iran

Mir Mozaffar FALLAHCHAI<sup>\*1</sup>

<sup>1</sup> Department of Forestry, Lahijan Branch, Islamic Azad University, Lahijan, Iran

### Abstract

In this study regeneration diversity from the aspects of evenness and richness were compared and examined in the managed and unmanaged Nave-Asalem forests in north of Iran. In order to perform this survey, two parcels - managed and unmanaged ones- were chosen for the reason that they had identical species and physiography. A random-systematic inventory was done with a 100 m× 100 m inventory network and 7R (700 m) sample pieces. For analyzing the data, different indexes of tree species regeneration in each sample piece was computed, and for the examination of considerable difference, the differences among the indexes means were used in two parts of the t-test. The results revealed that among the diversity mean of Shannon-wiener, N Hiill and N Mc-Arthur indexes in managed and unmanaged stands a considerable difference in a 5% level exists. Also among Brillouins's diversity index mean in two stands was a considerable difference in the levels of 1% and 5%. In this case the most increases were observed in N Hiill index with the amount of 1.973 and N Mc-Arthur index with the amount of 2.127 in the managed stand.

**Key words:** diversity, regeneration, beech, richness, evenness

### 1. Introduction

Biodiversity is essential for human's life continuation, economical issues, ecosystems resistance and function (Singh, 2002). So species diversity index is one of the most important bio diversity indexes that is used in evaluating the habitations and its quantity depends on the stability of its environment. A great biodiversity confirms that since there's a favorable environmental condition numerous species can settle in that area (Ardakani, 2004). In area that has been influenced by human intervention for along period, the transformed forest structure is considered as a biodiversity essential threatening factor (Battles et. al., 2001).

The forest management quality and method is also a kind of human intervention which will have a great influence on species diversity, competition, stand structure and forest ecosystem's functions (Nagaik et. al., 2005). Up to now a lot of studies have been done about biodiversity but studies about the comparison of tree species diversity regeneration in managed and unmanaged areas are just a few. For example; In a research have studied the wooden plants species diversity from the view point of diversity indexes in some parts of the managed and unmanaged areas of Arasbaran forests in Iran and have concluded that the indexes of richness, evenness and species diversity in the stands of the managed forest areas compares to the unmanaged areas have a great difference (Alijanpour et. al., 2004). Also studied and compared the estimation methods of forest tree biodiversity indexes in Neka-Zalem Roud Forest management plan and concluded that the best index in calculating the heterogeneousness in parcelle level is Shannon-wiener index and in calculating evenness the best index is Nee's modified index (Dastanghou, 2004). Pour Reza's (2004) studies in Darbandam located in Kermanshah province related to the forest quantitative situation in the managed and unmanaged areas reveals that generally the stand's qualitative and quantitative conditions are better in the managed area compared to the unmanaged area. Qomi Ovili et. al. (2006) evaluated the quantitative characteristics in the two managed plant communities in Noshahr's Khairoud Kenar forest, The results of this study revealed that in the Fagetum community during different periods, remarkable differences haven't been made in the quantitative characteristics, while in Fageto- carpinetum community these changes have been considerable. Fallahchai and Marvie Mohadjer (2005) study in Siyahkal forests in north of Iran, also show that as the height from sea level increases the amount of species (species richness) decreases but the species frequency (Evenness) increases, and the most species diversity is found in 100 to 700 meters above the sea level and the least species diversity is found in 700 meters altitude above. In another research

\* Corresponding author / Haberleşmeden sorumlu yazar: Tel.: +00981342222602; Fax.: +0098142222602; E-mail: mir\_mozaffar@yahoo.com

the influence of different forest management systems on plants species diversity in the central parts of Japan's Fagetum forests was studied (Nagaik et. al., 2005).

The results of this research showed that difference that was found in the species compositions among the primary forests and exploited forest isn't very considerable by shelter-wood method, while among the primary and afforestation forests and secondary forests has been a remarkable difference this is due to the dominance of regeneration trees renewal. Also in India, Parthasarathy (1999) studied the tree diversity in the ever green forest inter vented and non intervened sits. The results showed that species diversity, species type, species richness and their abundance is referred to human interference. In this way another study considered the plant diversity and general structures and concluded that there is a greater evenness in natural stands compared to the intervened ones. Also the flora species compounds, the covering percentage of each species and Simpson diversity index are appropriate indexes in order to assume the under study area's heterogeneousness. Rodringuez et. al. (2004) studied forest biodiversity indexes in the area of Anders in Colombia.

The output of the study showed that factor of being above the sea level and geomorphologic differences are some of the most important factors in causing biodiversity. And population density and economical activities are introduced as the negative elements for biodiversity. Thus management based on protection can be a suitable technique for preserving the forest species diversity. So the aim of this research is to consider and compare the tree species regeneration of forest stands in the managed and unmanaged areas with a resembling physiographic and species compounds.

## 2. Materials and methods

### 2.1. The under study area

One of the most abundant and economically important hardwood genera in northern hemisphere temperate forests is *Fagus* (Ertekin et. al., 2015). This study has been carried in Asalem Forests. Asalem forests are located in north of Iran in 37°, 38' northern latitude and 48°, 52' eastern longitude and its 800 meters above the sea level. The accomplishment locality of this study is the first series forests of Nave-Asalem that belongs to the seven Nove Anjiz district (figure 1) in which since 1969 the management plan has began in it. Generally this set is divided in to 48 parcelles and since the beginning its 23<sup>rd</sup> parcelle was managed as the testifier parcelle and up to now no intervention has taken place in it. The recent study is carried out in parcelle 23 (as the managed parcelle) and 12 (as the unmanaged parcelle). These tow parcelles are placed beside each other and many of their regional, edaphic, physiological characteristics are identical. Geologically they belong to the second geological era, and pedagogically the soil type is attritive humus and their mother rock is slate clay. The average annual rain in the project area is about 945 millimeters and the average annual heat temperature is 12.4 degree centigrade and the regions climate according to (Emberge) method is chilly humid.

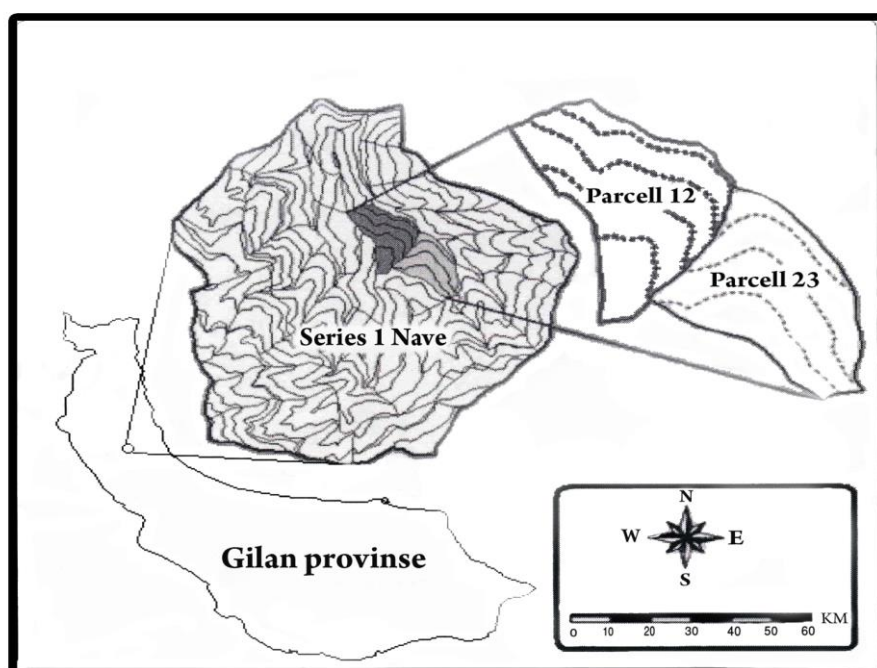

Figure 1. The under study area position in Gilan province



## 2.2. Inventory method

For this research parcelle 12 (unmanaged) with a 63 hectares measurement and parcelle 23 (managed) with a 43 hectares measurement were selected in Nave-Asalem series 1. Since in this area the stand form was harmonious and homogenous and carrying out the sample pieces was convenient and accurate the random – systematic sampling was used. The sample piece measurement was considered 7Rs (700 m) so that the tree inventory error placed on the sample piece border would be minimized. Generally 75 sample pieces (disconnectedly 32 sample pieces in the managed area and 43 sample pieces in the unmanaged area) were carried out in the area with the 100 × 100 network inventory and by noticing this case in this study the inventory intenseness was calculated as 5.2 percent.

## 2.3. Species diversity Indexes

Species diversity is a function of richness (number of species) and also the Evenness (Krebs, 1989). For the purpose of assuming species diversity, several indexes are available and in this research the most common ones are used in order to account the sample pieces species diversity.

Simpson Index (1949);

This index formula is as follows (Krebs, 1989)

$$1-D = 1 - \sum_{i=1}^s \left[ \frac{ni(ni-1)}{N(N-1)} \right]$$

In this 1-D is Simpson diversity index formula, s is the species quantity (richness),  $n_i$ ; is the abundance of i species and N is the abundance of all species. This index has a greater sensitivity towards the general covering species

in the community and its amplitude changes is between 0 to  $1 - \frac{1}{S}$ .

$N_2$  Hill (1973);

Hill by means of Simpson index (Krebs, 1989) introduced the following formula which specifies species quantity with more frequency.

$$N_2 = \frac{1}{D} = \frac{1}{\sum_{i=1}^s p_i^2}$$

In this formula,  $N_2$  is the number of species in great supply,  $p_i^i$  consanguineous abundance of i species, and amplitude changes of  $N_2$  is one to S (species quantity).

Shannon-Wiener Index (1949);

This index has a greater sensitivity to rare species in the community and its formula is as follows (Krebs, 1989).

$$H' = - \sum_{i=1}^s p_i \log_2 p_i$$

In which  $H'$  is Shannon-wiener's function, s and  $p_i^i$  in sequence are species quantity and consanguineous abundance of i species.

The amount of  $H'$  changes is among  $\log[N/(N-s)]$  to  $\log_s$  in which Mc-Arthur in 1965 by the means of Shannon-wiener function and through another formula calculated the number of the abundant species that is as follow (Krebs, 1989).

$$N_1 = 2^{H'}$$

In this formula  $N_1$  is the number of abundant species and  $H'$  is the Shannon-wiener's function. Brillouins Index;

As Shannon-wiener function this index is sensitive to the rare species abundance in the community or sample and its formula is as follows (Krebs, 1989).

$$H = \frac{1}{N} \log \left[ \frac{N!}{n_1!n_2!n_3!.....} \right]$$

In which H is Shannon-wiener's index, N the abundance of all species and  $n^1, n^2, n^3, \dots$  is related to the abundance of different species.

2.4. Statistical analysis

For the purpose of the data related to species diversity indexes Ecological Methodology Software was used in two areas and the remarkable difference between the means of the indexes was accounted by the t statistical test (Bihamta and Zareh, 2008) by the use of SPSS software.

3. Results

Comparing the diversity indexes regarding to tree species regeneration in the managed and unmanaged areas reveals that the amount of all indexes in the managed areas is more than unmanaged areas and these differences are

more obvious in Shannon-wiener index,  $N_2$  Hiill and Mc Arthur (table 1).

Table 1. the results of tree species regeneration diversity index in managed and unmanaged areas

Feature	Managed area			Unmanaged area		
	mean	Standard of deviation	Standard of error	mean	Standard of deviation	Standard of error
<b>Simpson Index</b>	0.574	0.191	0.034	0.449	0.279	0.042
<b>Shannon-Wiener</b>	1.077	0.420	0.074	0.788	0.509	0.077
$N_2$ <b>Hiill</b>	1.973	0.699	0.123	1.506	0.930	0.141
<b>Brillouins</b>	0.774	0.326	0.058	0.531	0.361	0.055
$N_1$ <b>MC Arthur</b>	2.127	0.732	0.129	1.597	0.974	0.148

Figurers 2 to 6 also show the mean and the Confidence limits of tree species regeneration diversity indexes in the managed and unmanaged areas. As seen except Simpson diversity index the other diversity indexes after 40 years managed management accomplishment and stand exploitation have a considerable difference with each other and considerably unmanaged areas wooden species regeneration diversity. Sapling and thicket have decreased in germination stage and in this case  $N_2$  Hiill index with the amount of 1.973 and MC Arthur index with the amount of 2.127 have had the greatest increase in the managed stand.

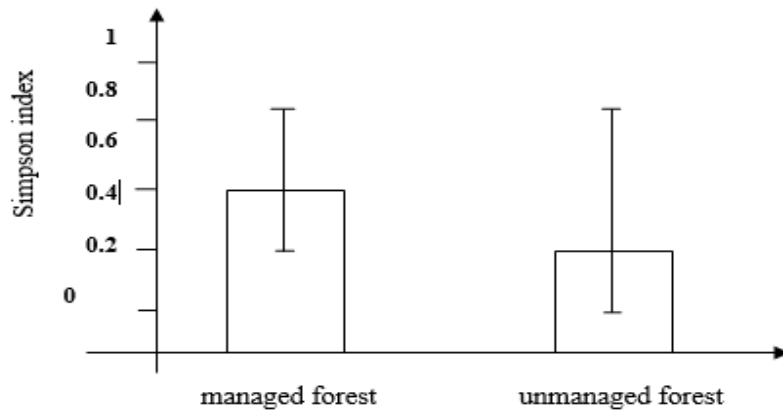

Figure 2. The mean and confidence limits of Simpsons diversity index managed and unmanaged stands

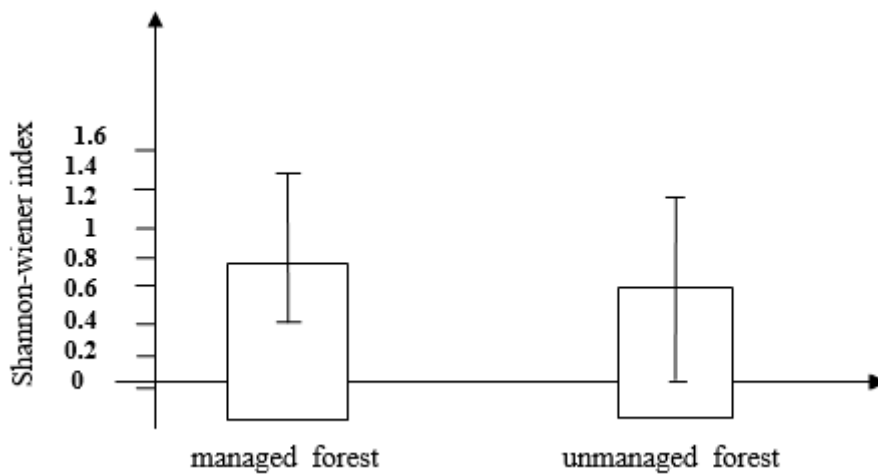

Figure 3. The mean and confidence limits of Shannon-Weiner's diversity index in managed and unmanaged stands

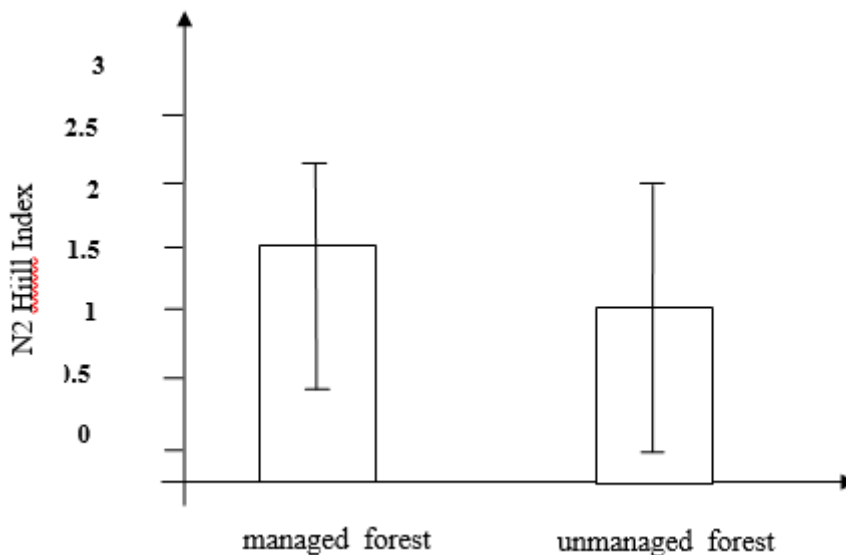

Figure 4. The mean and confidence limits of Hill's diversity Index in managed and unmanaged stands

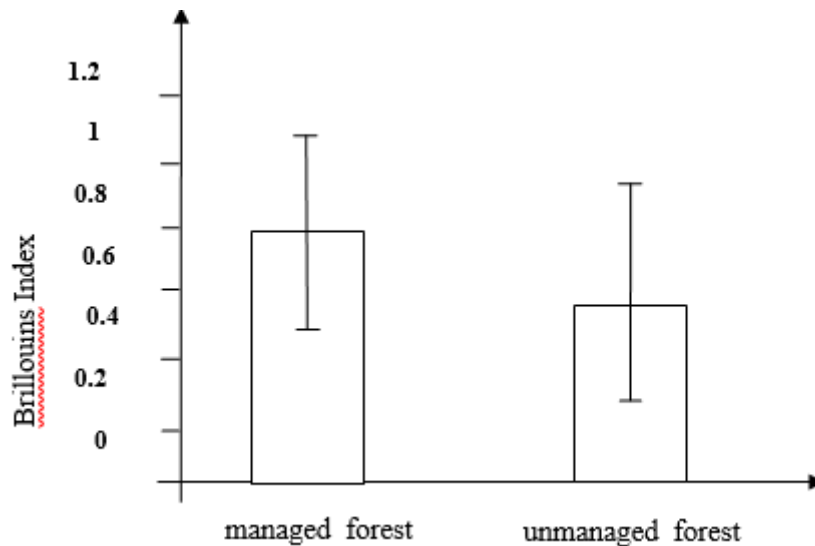

Figure 5. The mean and confidence limits of Brillouins diversity index in managed and unmanaged stands

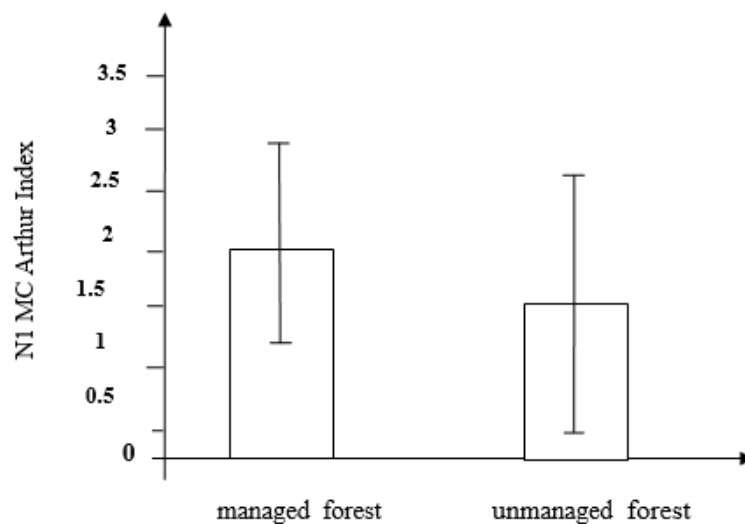

Figure 6. The mean and the confidence limits of MC Arthur's diversity Index in managed and unmanaged stands

In order to compare the tree species regeneration diversity means of different indexes the analysis result of managed and unmanaged areas are presented in table 2. Among Shannon-wiener diversity index,  $N_2$  Hill and  $N_1$  MC Arthur as noticed within the two stands is a considerable difference in a 5% level. Also among Brillouins diversity index mean within the two stands a considerable difference in 1 and 5% level is noticed. But among Simpson's diversity index no considerable difference has been noticed within the two stands in 1 and 5 percent level.

Table 2. The comparison of tree species regeneration diversity indexes in managed and unmanaged areas by t examination

Feature	Managed area	Unmanaged area	t
Simpson Index mean	0.574	0.449	1.71 <sup>ns</sup>
Shannon-wiener Index mean	1.077	0.788	2.61 *
$N_2$ Hill Index mean	1.973	1.506	2.38 *
Brillouins Index mean	0.774	0.531	2.997 **
$N_1$ MC Arthur Index mean	2.127	1.597	2.57 *

ns = non-significant      \* = it is significant at 0.05 level      \*\* = it is significant at 0.01 level

#### 4. Conclusions and discussion

From tree species regeneration biodiversity point of view in the stage of sapling and thicket, the species diversity volume according to  $N_2$  Hill index, Shannon-wiener, Brillouins and  $N_1$  MC Arthur within the two managed and unmanaged stands is a great difference, and in all cases the diversity index within the two managed stands have greater amounts compared to the unmanaged stand. In Qomi Ovili's (2006) studies regeneration diversity in Fageto-Carpinetum stand was more pure than Fagetum. In Alijanpour et. al. (2004) studies in Arasbaran region management based on protection lead to the growth of tree species regeneration diversity in the area. In the same case considering the regeneration diversity situation within the two stands indicates that management based on exploitation in the unmanaged area has decreased the regeneration accumulation in this stand. Smith (1996) tells the main reason of natural resource management is biodiversity protection and regeneration continuance, in Pour Reza's studies (2004) management based on protection has the stand's regeneration quantity. In this study the main reason for the decrease in the stand's regeneration accumulation was known as Fagetum stand's shade tolerant and over opening of the crown in exploited areas. In Tabari et. al. (2003) studies this reason has clearly been shown. In this course (Elliott and Swank, 1994; Schuler and Gillespie, 2000; Crow et. al., 2002; Brashears et. al., 2004) in their researches about exploitation's effect and result on regeneration accumulation and species element have obtained similar results. Thus unmanaged stands from the respect of many indexes have an undesirable condition compared to managed stands, and we can point out to the main factors as marking desirable and high quality trees in unmanaged stands, exploitation detriments, domesticated animals grazing and inaccurate management in these stands.

#### References

- Alijan Pour, A, Eshaghi Zad, J, Banj Shafii, A. 2004. Considering and comparing wooden plants in Arasbaran Managed and unmanaged areas, Iranian Journal of Forest and Poplar Research.,17: 125-132.
- Ardakani, M, R. 2004. Ecology, Tehran University publication. 340pp.
- Battles, J.J., Shlisky, A.J, Barrett, R.H., Heald, R.C., Diaz, B.H. 2001. The effects of forest management on plant species diversity in a Sierran conifer forest. For.Ecol. Manage., 146:211-222.
- Bihanta, M, R, Zareh Chahkouhi, M; A. 2008. Statistical principles in natural resources sciences. Tehran University publication., 300pp.
- Brashears, M.B., Fajvan, M.A., Schuler. T. M. 2004. An assessment of canopy stratification and tree species diversity following clear cutting in central Appalachian hardwoods. For. Sci.50:54-64.
- Crow, T.R., Buckley, D.S., Nauertz, E.A., Zasada, J. C. 2002. Effects of management on the composition and structure of Northern hardwood forests in upper Michigan. For. Sci.48:129-145.
- Dastango, D. 2004. Comparing the inventory methods of forest trees species diversity indexes (Nekah management plan - Zalemroud). Forestry Master thesis. Agriculture science University and Gorgan's natural resources., 87pp.
- Elliott, K.J., Swank, W.T. 1994. Changes in the Southern Appalachians. Vegetatio, 115:11-18.
- Ertekin, M., Kirdar, E., Ayan, S. 2015. The effects of exposure, elevation and tree age on seed characteristics of *Fagus orientalis* Lipsky. *South-east Eur for* 6 (1): 15-23. DOI: <http://dx.doi.org/10.15177/seefor.15-03>.
- Fallahchai, M.M, Marvie Mohadjer, M. 2005. The ecological role of height above the sea level in Siyahkal forest tree species diversity in north of Iran. Iranian Journal natural resource', 58: 89-99.
- Krebs, C.J. 1989. Ecological Methodology. University of British Columbia, Harper collins publisher., 432pp.
- Nagaik, T., Kamitani, T. and Nakshizuka, T. 2005. Effects of different forest management systems on plant species diversity in a *Fagus crenata* forested landscape of central Japan. Published on the NRC research press, available on: <http://cjfr.nrc.ca>
- Onaindia, M., Dominguez, I., Albizu, I., Garbuis, c. and Aezaga, I. 2004. Vegetation diversity and vertical structure as indicators of forest disturbance. For. Ecol. Manage., 195:341-354.
- Parthasarathy, N. 1999. Tree diversity and distribution in undisturbed and human – impacted sites of tropical wet evergreen forest in southern western Ghats, India. Biodiversity and conservation, 8:1365-1381.
- Pour Reza, M. 2004. The survey of forest quantitative and qualitative situation in managed and unmanaged areas in Darbadam, Kermanshah region. Masters thesis, Natural resources Department in Guilan University, 57pp.
- Qomi Ovili, A, Hosseini, S.M, Metaji, 1, Jalali, Gh. 2006. Considering the wooden species biodiversity and regeneration in two managed flora communities in Khairoud Kenar area of Noshahr, Environmental Journal.43: 101-106.
- Rodriguez, N., Armenteras, D., Rincon, M.H.A., Morales, M., Sva, S. 2004. Forest biodiversity indicators in the Colombia Andes. Institute de investigation de recursos biologios Alexander Von Humboldt Carrera Bogota, 7:20-35.
- Schuler, T.M., Gillespie, A.R. 2000. Temporal Patterns of woody species diversity in a Central Appalachian forest from 1856 to 1997. J.Torr. Bot. Soc. 127:149-161.
- Shannon, C.E. 1949. The mathematical theory of communication. In: Shannon, C.E., Wiener, W. (Ed.). The mathematical theory of communication. University of Illinois press, Urbana, 29-125p.
- Smith, F. 1996. Biological diversity, ecosystem stability and economic development. J. Ecological Economics, 16:191-203.
- Simpson, E.H. 1949. Measurement of diversity, Nature, 12:1-20.
- Singh, J.S. 2002. The biodiversity crisis: a multifaceted review. Curr.sci.82: 499-500.
- Tabari Kouchak Sarai, M, Fayaz, P, Emadiyan, F, Espahboodi, K, Pour Majidiyan, M. 2003. The effect of hold mesuration on Fagetum sappling's survival, growth and freshness. Journal of Pajouhesh Va Sazandgi .3: 32-36.

(Received for publication 17 September 2015; The date of publication 15 August 2016)



## The effect of magnetic field application on chemical composition in *Fagus orientalis* Lipsky. seed

Nezahat TURFAN<sup>\*1</sup>, Esra Nurten YER<sup>2</sup>, Sezgin AYAN<sup>2</sup>, Burcu HASDEMİR<sup>3</sup>, Aybaba HANÇERLİOĞULLARI<sup>4</sup>

<sup>1</sup> Kastamonu Univ. Faculty of Arts and Sciences, Department of Biology, Kastamonu, Turkey

<sup>2</sup> Kastamonu University Faculty of Forestry, Department of Forestry, Kastamonu, Turkey

<sup>3</sup> Kastamonu University Institute of Sciences Forest Engineering, Kastamonu, Turkey

<sup>4</sup> Kastamonu Univ. Faculty of Arts and Sciences, Department of Physics, Kastamonu, Turkey

### Abstract

Previous studies have shown that magnetic field (MF) can affect the germination process in some seeds of agricultural crops and influence on some seed characteristics. Therefore, in the present study, the effects of MF applications on the seed of *Fagus orientalis* were investigated. The unstratified seed were exposed to different treatment periods as 20, 60 and 120 min. and varied MF intensities as 200 and 400 mT. Accordingly, total protein, glucose, fructose, sucrose, starch content and  $\alpha$ -amylase activity level, in the seeds were investigated. MF applications had affected total protein,  $\alpha$ -amilaz aktivite level, glucose, fructose, sucrose, and starch contents at significant levels. MF had negative effects on soluble protein content and  $\alpha$ -amylase activity level in the seeds. Soluble starch content increased as the MF treatment progressed, except the treatment of 200 mT at 20 min. as well control treatment.

**Key words:** magnetic field, germination, Oriental beech, seed, stress factors

----- \* -----

### Magnetik alan uygulamalarının doğu kayını (*Fagus orientalis* Lipsky.) tohumunun kimyasal içeriğine etkisi

#### Özet

Önceki çalışmalar magnetik alanın, bazı tarımsal ürün tohumlarının çimlenme sürecini etkileyebildiğini ve bazı tohum karakterleri üzerine etkileri olduğunu göstermiştir. Bu sebeple bu çalışmada; magnetik alan uygulamalarının doğu kayını tohumları üzerine etkileri araştırılmıştır. Katlama ön işlemine tabi tutulmayan tohumlar; farklı sürelerde (20, 60, 120 dakika) ve 200 ile 400 mT yoğunluktaki magnetik alan uygulamasına maruz bırakılmıştır. Magnetik alan uygulamasına maruz bırakılan tohumlarda; toplam protein, glukoz, fruktoz, sukroz, nişasta içeriği ve  $\alpha$ -amilaz aktivite seviyesi analiz edilmiştir. Magnetik alan uygulamaları, toplam protein,  $\alpha$ -amilaz aktivite seviyesi, glukoz, fruktoz, sukroz ve nişasta içeriğini önemli ölçüde etkilemiştir. Magnetik alan uygulaması, tohumdaki çözünebilir protein içeriği ve  $\alpha$ -amilaz aktivite seviyesini negatif etkilemiştir. 200 mT yoğunluk ve 20 dakika süreli magnetik alan uygulaması hariç, diğer magnetik alan işlemlerinde çözünebilir nişasta içeriği artmıştır.

**Anahtar kelimeler:** magnetik alan, çimlenme fizyolojisi, Doğu kayını, tohum, stres faktörleri

#### 1. Giriş

Doğu kayını (*Fagus orientalis* Lipsky) 1,7 milyon ha yayılış alanı ile Türkiye ormanlarında en geniş yayılışa sahip dördüncü türdür (Anonim, 2006). Doğu kayınının dikey yayılışı Balkan'larda 10-800 m'ler arasındadır. Türkiye'de ise, Karadeniz Bölgesi'nin vadi içlerinde 1500-1700 m'ye ve Ege Bölgesi dağlarında ise 2000 m'ye kadar çıkmaktadır. Doğu kayını; Türkiye'deki geniş yayılış alanı ile hem ekolojik ve silvikültür açıdan önemli yer tutmakta, hem de ağaç servetinin yıllık etası ile ekonomiye önemli katkı sağlamaktadır. Ayrıca, Doğu kayını, Milli Ağaç Islahı Programı'na dahil olan geniş yapraklı tek ağaç türüdür (Saatçioğlu, 1969; Atay, 1987; Atalay, 1992).

\* Corresponding author / Haberleşmeden sorumlu yazar: Tel.: +903662801933; Fax.: +903662154969; E-mail: nturfan@kastamonu.edu.tr

Manyetik alan (MA), bir abiyotik çevre faktörü olarak, bitki tohumlarının dormasisinin kırılmasında, çimlenmesinde, bitki büyüme ve gelişmesi üzerine olan etkileri ve bu etkilerin uygulamada kullanılabilmesi üzerine yürütülen çalışmalar, uzun zamandan beri yapılmaktadır (Garcia ve Arze, 2001; Eşitken, 2006; De Souza vd., 2006; Pintilie vd., 2006; Agustrina vd., 2012).

Değişik bitki türü ve çeşitleri ile yapılan çalışmalarda, MA uygulamalarının, bitkilerde çiçek sayısı, verimi (Matsuda vd., 1993; Danilov vd., 1994; Samy, 1998), çimlenme yüzdesi ve hızına (Amaya vd., 1996; Namba, 1996; Namba vd., 1998; Torres vd., 1999; Novitsky vd., 2001; Aladjadjiyan and Teodora, 2003; Podlesny vd., 2005; Criveanu ve Taralunga, 2006; Vashist ve Nagarajan, 2010; Pourakbar ve Hatami, 2012), topraktan mineral maddelerin alınmasına ve taşınmasına, fide büyüme hızına (Florez vd., 2007; Vashisth ve Nagarajan, 2010; Agustrina vd., 2012),  $\alpha$ -amilaz aktivitesi dahil olmak üzere diğer proteolitik ve hidrolitik enzimlerin aktivitelerine (Pintilie vd., 2006; Atak vd., 2007; Pourakbar, 2013), klorofil içeriğine (Novitsky vd., 2001; Atak vd., 2007) ve genç bitkilerde parankimatik hücrelerin, iletim demetlerinin ve stoma hücrelerinin boyutlarını olumlu yönde etki sağladığı rapor edilmiştir (Agustrina vd., 2012). Ayrıca, yapılan çalışmalarda; MA uygulamalarının, çimlenme kapasitesi, süresi ve oranı, fide gelişimi, protein sentezi, enzim aktivitesi, nükleik asit içeriği, solunum hızı, fotokimyasal aktivite gibi fizyolojik ve kimyasal işlevler, taze ve kuru ağırlık, kök ve gövde boyu, bitkinin meyve verimi ve ortalama meyve ağırlığı gibi morfolojik özelliklerini de olumlu yönde etkilediği bildirilmektedir (Lebedev vd., 1975; Namba vd., 1995; Phirke vd., 1996; Levin ve Ernst, 1997; Aladjadjiyan and Teodora, 2003; Stange vd., 2002; Eşitken, 2002; Rochalska ve Orzeszko 2005; De Souza vd., 2006; Pourakbar, 2013).

MA uygulamalarının bitki büyüme ve gelişmesi üzerine etkili olmadığı (Magnusson, 1984) ya da olumsuz yönde etki ettiği de ifade edilmektedir (Dunlop ve Schmidt, 1965). Bu nedenle, MA uyarımının doğasına ilişkin araştırmaların yürütülmesine ihtiyaç duyulmaktadır. Bitkilerin MA'ya cevapları MA'ın sıklığına, maruz kalma süresine, tohum hazırlama yöntemlerine, türe ve tohumların özelliklerine bağlı olarak değişebilmektedir (Dhawi vd., 2009).

Tohum kalitesi, plantasyon ormancılığının başarısı için hayati öneme sahiptir. Tohumun kimyasal içeriği ise en önemli kalite markörüdür (Güney vd., 2013). Tohumun kimyasal içeriğini oluşturan bileşikler, fotosentez ve onun uzantısı olan biyosentez tepkimelerinde üretilmektedir. Yaprak gibi ömenli kaynaklarda sentezlenen şekerlerin bir kısmı floem aracılığıyla sentezlendikleri yerler olan ve havuz olarak nitelendirilen köklere, gelişmekte olan yapraklara, meyvelere, tohuma, rizom ve soğan gibi depo organlara taşınırlar. Sentez ürünlerin kalan kısmı da solunum reaksiyonlarında parçalanarak ATP üretimi, büyüme ve gelişmede kullanılacak karbon iskeletleri, aminoasitler, nükleotidler, porfirin pigmentleri, lipitler, steroller, karotenoitler, antosiyaninler, alkaloidler, hormonlar ve çeşitli aromatik bileşiklerin öncülerini oluştururlar (Plaxton, 1996; Dennis ve Blakeley, 2000).

Tohumun kimyasal içeriği, tohumda biriken depo maddelerine ve bunların miktarlarına bağlıdır. Bu yönüyle orman ağaçlarının tohum depo maddelerinin kimyasal içeriği üzerine MA uygulamalarının etkileri ve özellikle de  $\alpha$ -amilaz enzim aktivitesi değişimi gibi konular yok denecek kadar azdır. Bu çalışmada fizyolojik derin dormansi gösteren Doğu kayını tohumlarına (Yılmaz, 2005; Gezer ve Yücedağ, 2006; Rezaei vd, 2011; Ertekin vd., 2015) yapılan farklı MA uygulamalarının tohumun kimyasal içeriğine (protein, nişasta, çözünebilir şeker vb.) ve  $\alpha$ -amilaz aktivitesine olan etkisi araştırılmıştır.

## 2. Materyal ve yöntem

*orientalis* Lipsky) tohumları kullanılmıştır. Tohumlar herhangi bir ön işleme tabi tutulmadan 200 ve 400 mT olmak üzere farklı MA şiddetine 20, 60 ve 120 dk süreyle maruz bırakılmıştır. Kontrol ve uygulama grubuna ait tohumlarda protein, nişasta, glukoz, fruktoz ve sukroz içeriği belirlenmiş ve  $\alpha$ -amilaz enzim aktivitesi ölçülmüştür.

### 2.1. Tohumların çözünebilir protein içeriğinin belirlenmesi

Tohumların çözünebilir protein içeriği Bradford (1976) yöntemine göre biraz değiştirilerek belirlenmiştir. Yaklaşık 0,5 gr tohum 5 mL 50 mM  $\text{KH}_2\text{PO}_4$  (pH 7) tamponu ile özütlenmiştir. Eppendorf tüplerinde +4°C'de 15,000 rpm'de 20 dakika süreyle santrifüjlenen örneklerden 10  $\mu\text{L}$  alınarak üzerine 2,5 mL Coomassie Brilliant Blue G-250 (CBB) ilave edilmiştir. Bu haldeki örnekler 10 dakika inkübe edildikten sonra UV-vis spektrofotometrede 595 nm'de BSA ile hazırlanan standart grafik yardımıyla absorbansları ölçülmüş ve tohum protein içeriği mg/g taze ağırlık (TA) belirlenmiştir.

### 2.2. Tohumların glukoz, fruktoz, sukroz ve nişasta içeriğinin belirlenmesi

Glukoz, fruktoz ve sukroz miktarının belirlenmesi anthron ayracı kullanılarak Pearson vd. (1976) yöntemine göre yapılmıştır. 1 g örnek 50 ml %80'lik etanolde, +4 °C'de 24 saat inkübe edilmiş ve süzülümüştür. Süzüntü glikoz tayini için ayrılırken, kalan posa +4 °C'de 24 saat 50 ml saf suda inkübe edilmiş ve tekrar süzülümüştür. Bu süzüntü de fruktoz tayini için kullanılırken kalan posa +4 °C'de 24 saat 15 ml perklorik asit ile inkübe edilerek süzülümüştür ve elde edilen son süzüntü de sakkaroz tayini için kullanılmıştır. Süzüntülerin evaporasyonda (60°C su banyosunda) etanolü uçurulmuştur. 2 ml örnek üzerine 4 ml anthron ayracı eklenerek 10 dk sıcak suda bekletilmiş ve oda sıcaklığına

soğutmuştur. Spektrofotometrede glikoz ve früktoz örneğinin 630, sakkaroz örneğinin ise 620 nm’de absorbansları kaydedilmiştir. Glikoz standartlarından elde edilen eğriden glikoz ve toplam nişasta miktarı, früktoz standart eğrisinden früktoz ve sakkaroz standart eğrisinden de sakkaroz miktarı belirlenmiştir (mg/g doku). Nişasta miktarı (toplam karbohidrat), glikoz standart eğrisinden elde edilen denklemden toplam karbohidrat miktarları belirlenmiştir.

### 2.3. $\alpha$ -Amilaz enzim aktivitesinin belirlenmesi

$\alpha$ -amilaz enzim aktivitesi mg protein başına hidrolizlenen nişasta miktarı olarak, BSA’nın standart olarak kullanıldığı Bradford (1976) yöntemine göre hesaplanmıştır.

### 2.4. İstatistiki analiz

Denemeler, üç tekrarlı yapılmıştır. Çalışma sonucunda elde edilen verilerin istatistiki analizleri, SPSS for Windows 20.0 Evaluation Version istatistik programı kullanılarak gerçekleştirilmiştir. Kontrol ve uygulama grupları arasındaki farklılıklar tek yönlü varyans analizi (one-way ANOVA) ile analiz edilmiştir. Varyans analizi sonrası  $P<0,05$  önemlilik değerinde farklılıkları belirlemek için Tukey çoklu testi uygulanmıştır.

## 3. Bulgular

Ön işleme tabi tutulmamış Doğu kayını tohumlarına uygulanan farklı süre ve şiddetlerdeki MA uygulamasının, tohumlardaki toplam protein içeriği,  $\alpha$ -amilaz aktivitesi, glukoz, fruktoz, sukroz ve nişasta içeriğine etkilerine ilişkin veriler Tablo 1’de verilmiştir. Tablo 1’e göre; MA uygulamalarının toplam protein içeriği,  $\alpha$ -amilaz aktivitesi, glukoz, fruktoz, sukroz ve nişasta içeriklerine etkileri, MA’nın şiddeti ve süresine bağlı olarak istatistiki olarak ( $P<0.05$ ) farklılık göstermiştir.

Tablo 1. MA’nın farklı uygulama süresi ve şiddetinin tohumun çözünebilir şeker ve nişasta içeriği ile  $\alpha$ -amilaz aktivitesine olan etkisi<sup>1</sup>

Şiddet (mT)	Süre (dk)	Protein*	Glukoz**	Fruktoz**	Sukroz**	Nişasta***	$\alpha$ -Amilaz****
<b>Kontrol</b>		90.505±0.027 <sup>e</sup>	30.58±0.24 <sup>c</sup>	7.65±0.0605 <sup>c</sup>	37.4±0.003 <sup>d</sup>	91.16±0.0004 <sup>b</sup>	21.7±0.007 <sup>e</sup>
<b>200</b>	<b>20</b>	84.85±0.0405 <sup>c</sup>	-185.2±0.503 <sup>a</sup>	-46.3±0.19 <sup>a</sup>	38.13±0.0034 <sup>f</sup>	-550.05±0.002 <sup>a</sup>	7.57±0.0053 <sup>c</sup>
	<b>60</b>	56.9±0.0405 <sup>a</sup>	54.31±0.43 <sup>d</sup>	13.58±0.11 <sup>d</sup>	37.26±0.002 <sup>c</sup>	159.84±0.0011 <sup>d</sup>	5.63±0.007 <sup>a</sup>
	<b>120</b>	90.05±0.027 <sup>f</sup>	230.44±0.19 <sup>f</sup>	57.61±0.046 <sup>f</sup>	37.06±0.003 <sup>b</sup>	688.04±0.002 <sup>f</sup>	9.56±0.00405 <sup>f</sup>
<b>400</b>	<b>20</b>	61.52±0.027 <sup>b</sup>	249.8±0.37 <sup>e</sup>	62.44±0.092 <sup>e</sup>	38.36±0.0055 <sup>e</sup>	746.72±0.005 <sup>e</sup>	7.15±0.007 <sup>c</sup>
	<b>60</b>	89.18±0.027 <sup>e</sup>	-43.7±0.37 <sup>b</sup>	-10.93±0.092 <sup>b</sup>	30.93±0.004 <sup>a</sup>	132.37±0.001 <sup>c</sup>	7.48±0.027 <sup>d</sup>
	<b>120</b>	85.83±0.027 <sup>d</sup>	58.43±0.32 <sup>e</sup>	14.61±0.08 <sup>e</sup>	37.9±0.005 <sup>c</sup>	173.57±0.002 <sup>e</sup>	7±0.0015 <sup>b</sup>

<sup>1</sup>İstatistiksel olarak  $p<0.05$  güven düzeyi ile anlamlı farklılık vardır (Tukey Testi); \*mg/g TA; \*\*  $\mu$ g/g TA; \*\*\*  $\mu$ g/g TA; \*\*\*\* EU/mg Protein

### 3.1. Çözünebilir protein içeriği değişimleri

Tohumların toplam çözünebilir protein içeriği MA’nın artan süre ve şiddetine bağlı olarak kontrole kıyasla istatistiki olarak belirgin bir azalma göstermiştir. Kontrole kıyasla en düşük protein içeriği değeri MA uygulamalarının 200 mT 60 dk (%37,14) ve 400 mT 20 dk (%32) dozlarında belirlenmiştir ( $P<0.05$ ) (Tablo 1, Şekil 1).

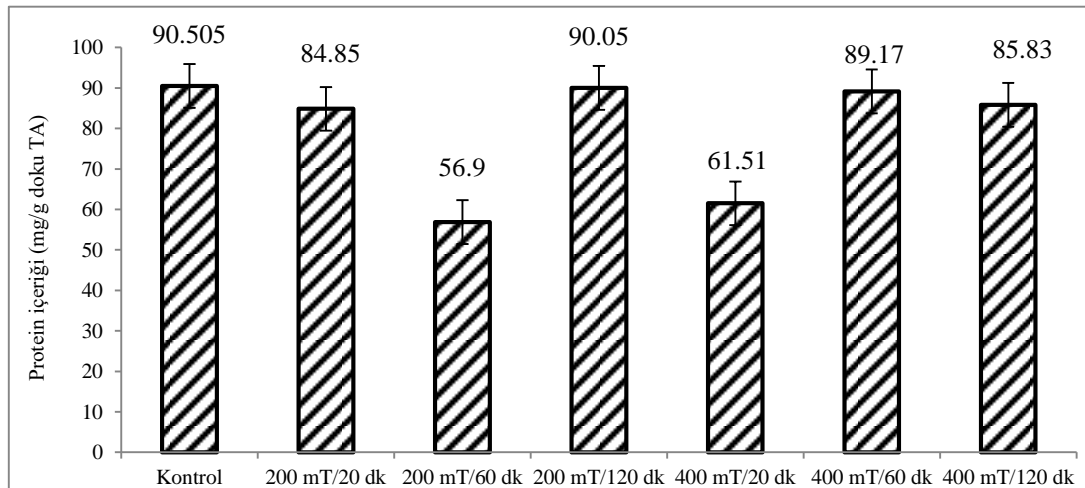

Şekil 1. Farklı süre ve şiddetlerdeki MA uygulamasının tohum toplam çözünebilir protein içeriğine etkisi



### 3.2. Çözünabilir şeker içeriği (glukoz, fruktoz ve sukroz) değişimleri

Tohumların glukoz içeriği 200 mT'de 20 dk ve 400 mT'de 60 dk MA uygulamalarında negatif olarak belirlenmiştir. Kontrole kıyasla en yüksek glukoz içeriği 400 mT'de 20 dk (8,17 kat) ve 200 mT'de 120 dk (7,54 kat) süreyle olan MA uygulamalarında bulunmuştur (Tablo 1, Şekil 2,  $P<0.05$ ).

Tohumların fruktoz içeriğindeki değişim glukoz değerleriyle benzerlik göstermiştir. 200 mT'de 20 dk ve 400 mT'de 60 dk MA uygulamalarında fruktoz içeriği negatif olarak belirlenmiştir. Kontrole kıyasla en yüksek fruktoz içeriği 400 mT'de 20 dk (8,17 kat) ve 200 mT'de 120 dk (7,54 kat) MA uygulamalarında kaydedilmiştir (Çizelge 1, Şekil 2,  $P<0.05$ ).

Tohumların sukroz içeriği, MA uygulamalarından istatistiki olarak önemli olmakla birlikte, glukoz ve fruktoz içeriklerinde olduğu gibi yüksek değişimler saptanmamıştır. Kontrole kıyasla en düşük sukroz içeriği ve 400 mT'de 60 dk (%17,3) süreyle olan MA uygulamasında, en yüksek sukroz içeriği ise 400 mT'de 20 dk süreyle olan MA uygulamasında elde edilmiştir (Tablo 1, Şekil 2).

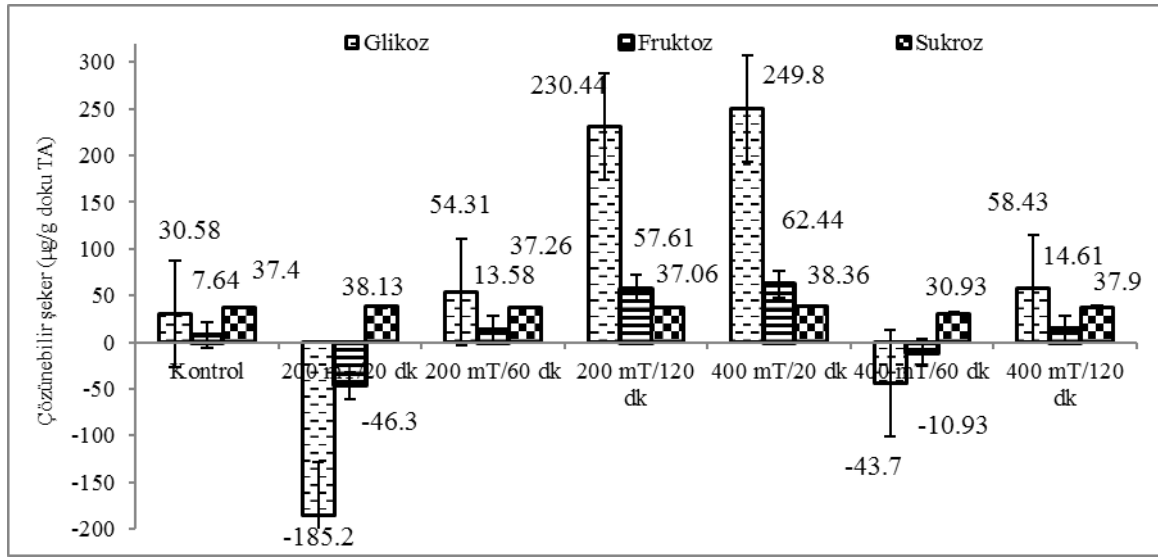

Şekil 2. Farklı süre ve şiddetlerdeki MA alan uygulamasının çözünabilir şeker içeriğine etkisi

### 3.3. Toplam çözünabilir nişasta içeriği değişimleri

Nişasta (%) içeriği, 200 mT'de 20 dk MA uygulaması hariç, diğer uygulama gruplarında kontrole kıyasla oldukça yüksek bulunmuştur. Kontrole kıyasla en yüksek nişasta içeriği 400 mT'de 20 dk (8,2 kat), 200 mT'de 120 dk (7,55 kat), 400 mT'de 120 dk (%90,41), 200 mT'de 60 dk (%75,35) ve 400 mT'de 60 dk (%45,21) süreyle olan MA uygulamalarında belirlenirken, en düşük nişasta içeriği ise 200 mT'de 20 dk (6 kat) süreyle olan MA uygulamasında belirlenmiştir (Tablo 1, Şekil 3,  $p<0.05$ ).

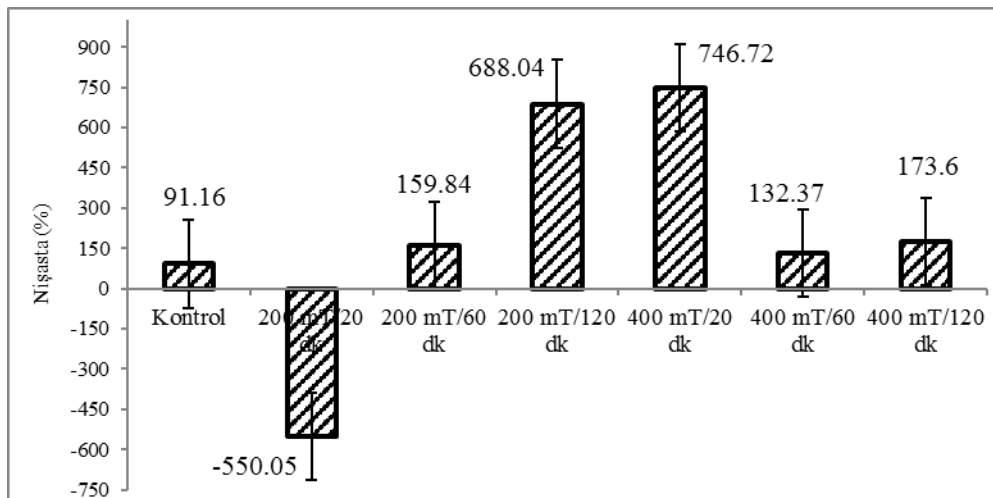

Şekil 3. Farklı süre ve şiddetlerdeki MA alan uygulamasının toplam nişasta içeriğine etkisi

### 3.4. Tohumların $\alpha$ -Amilaz enzim aktivitesi deęişimleri

Tohumların toplam  $\alpha$ -amilaz (EU/mg Protein) enzim aktivitesi tüm uygulama gruplarında kontrole kıyasla önemli ölçüde azalmıştır. MA uygulamaları kontrole kıyasla  $\alpha$ -amilaz aktivitesini sırasıyla 200 mT'de 60 dk uygulamasında 3,86 kat, 400 mT'de 120 dk uygulamasında 3,1 kat, 20 dk'da 3 kat ve 60 dk'da 3,1 kat, 200 mT'de 20 dk uygulamasında 2,87 kat ve 120 dk'da 2,27 kat azaltmıştır (Tablo 1, Şekil 4,  $P < 0.05$ ). Mevcut analizler doğrultusunda 400 mT MA uygulamaları genel olarak tohumların enzim aktivitesini daha çok düşürdüğü söylenebilir.

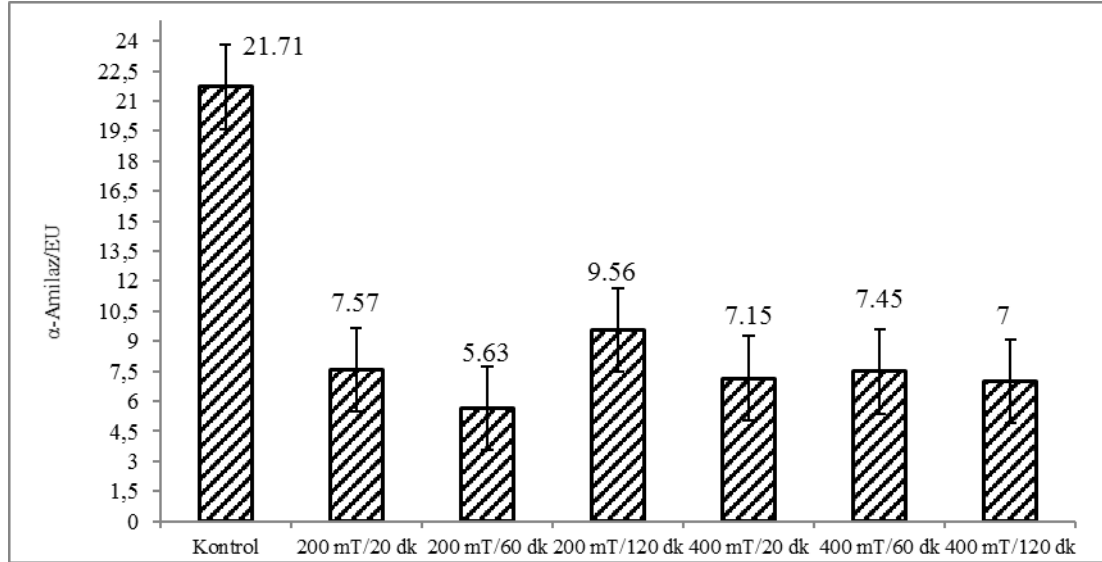

Şekil 4. Farklı süre ve şiddetlerdeki MA uygulamalarının  $\alpha$ -amilaz enzim aktivitesine üzerine etkisi.

## 4. Sonuçlar ve tartışma

Farklı süre ve şiddetlerde manyetik alan uygulamasının; Doęu kayını tohumlarının  $\alpha$ -amilaz enzimi aktivitesi, toplam çözünür protein miktarı, nişasta, sukroz, fruktoz ve glukoz içerięi üzerine etkileri araştırıldığı bu çalışmada; MA uygulamalarının Doęu kayını tohumlarının kimyasal içerięi üzerine genel olarak olumsuz etki yaptığı tespit edilmiştir. Protein içerięine göre, 200 mT'de 60 dk ve 400 mT'de 120 dk MA uygulamaları  $\alpha$ -amilaz aktivitesi ve nişasta içerięine göre tüm tüm uygulamalarda, glukoz ve fruktoz deęerlerine göre, 200 mT'de 20 dk ve 400 mT'de 60 dk MA uygulamaları, sukroz deęerlerine göre, 400 mT'de 60 dk ve tüm veriler esas alındığında ise 200 mT'de 60 dk ve 400 mT'de 60 dk MA uygulamaları, Doęu kayını tohumlarının kimyasal içerięi ve enzim aktivitesini en çok etkileyen uygulamalar olduęu belirlenmiştir.

Endosperm ve kotelidonların nişasta, lipit ve protein içerięi çimlenme, dormansi, embriyonun büyümesi ve gelişmesi gibi fizyolojik olayları kontrol eder. Bu bileşiklerin tohumda bulunma oranı, bitkinin genetik yapısı, bitkinin yaşı, iklim, yükselti, toprağın fiziksel ve kimyasal özellikleri, floemin metabolitleri taşıma kapasitesi ve hızı, tohumun gelişme safhası ve metabolitler için rekabet gücü gibi etmenlere baęlı olarak deęişmektedir (Zimmermann, 1975; Dornbos ve Mullen, 1992; Prasad vd., 2000; 2002; Minchin ve Lacoite, 2005; Porch, 2006; Garcia vd., 2006; Hammond ve White, 2008; Güney vd., 2013). Bitkilerde büyüme ve gelişmenin, fotosentez ve solunum metabolizmasının dengesine baęlı olarak gerçekleştii bilinmektedir (Roper vd., 1988). Aktif büyümenin baskın olduęu erken safhada katabolizma hızlı olduęu, gelişmenin ilerledięi olgunlaşma fazında ise katabolizma ve anabolizmanın dengelendięi fakat, gelişmenin tamamen tamamlandıęı ve yaşlanmanın başladığı evrede ise katabolizmanın düştüğü, anabolizmanın ise arttığı bildirilmiştir (Komrnink ve Kruger, 1984; Krugger, 1997; Hamilton vd., 2001; Hammond ve White, 2008). Bilindięi gibi çimlenme, bitki büyüme ve gelişim safhasının birinci basamağını oluşturmaktadır. Bu safhada tohumda bulunan organik bileşiklerin solunum reaksiyonları ile yıkıma uğramasıyla oluşan ATP ve metabolitler embriyonun büyüme ve gelişmesinde, azot, kükürt, karbon ve enerji kaynağı olarak kullanılmaktadır. Nitekim birçok araştırmacı çimlenmenin erken safhalarında solunum hızının yükseldiğini ve buna baęlı olarak da hücrelerde glikoz ve fruktoz miktarında artış olduğunu bildirmişlerdir (Bewley and Black, 1994; Bewley, 1997; Subbarao vd., 1988; Ficher, 1989; Holdsworth vd., 1999; Debeaujon ve Koornneef, 2000; Guglielminetti vd., 2000; Kaneko vd., 2002).

Çalışmada; farklı süre ve şiddetlerde manyetik alan uygulanmış, katlama işlemine maruz bırakılmamış tohumların, toplam çözünebilir protein içerięi, tüm uygulama gruplarında kontrole kıyasla düşük bulunmuştur (Tablo 1, Şekil 1). Bu sonuçların, sadece MA uygulamalarından kaynaklanmadığı, olasılıkla kayın tohumlarının yağ içerięinin protein miktarından daha fazla olmasından, soğuk şoku uygulamasının yapılmamasından ve MA'nın proteinlerin hidrolizinden sorumlu enzimlerin aktivasyonunu baskılamasından kaynaklanmış olabileceęi düşünülmektedir. Elde edilen bu bulgular, Doęu kayını tohumunun kimyasal içerięini ilgili yapılan dięer çalışmalar ile uygunluk

göstermektedir. Ayaz vd. (2011) Doğu kayın tohumlarının %45 yağ asidi,%22,5 protein, Yılmaz (2005) ise, %48,69 yağ ve %29,04 protein içerdiğini rapor etmişlerdir.

Glukoz, nişasta sentezinde ve hücre sel solunumun başlangıç tepkimelerinde rol oynayan bileşiktir (Plaxton, 1996; Zeaaman vd., 2007; Winter ve Huber, 2000). Glukoz, çimlenme üzerine etkisini ABA ile birlikte yürütmektedir (Dekkers vd., 2004; Gibson, 2005). Bununla birlikte tohum çimlenmesinde ABA ile glukoz, fruktoz, sukroz ve mannoz gibi şekerler arasındaki ilişki henüz netlik kazanmamıştır (Arenas-Huertero vd., 2000). Bu çalışmada, 200 mT 20 dk ve 400 mT 60 dk MA uygulamalarında glukoz değeri negatif bulunmuştur. Glukoz miktarına ilişkin elde ettiğimiz değerler yapılan farklı çalışmalar ile örtüşmektedir (To vd., 2002; Price vd., 2003; Rolland vd., 2006; Dekkers ve Smeekens, 2007). *Arbidopsis thaliana* tohumlarının doku kültürü ortamında çimlendirme çalışmalarında, yüksek derişimlerde (300 mM) glukoz uygulamasının tohumlarında ABA birikimine neden olduğu ve tohum çimlenmesini engellediği, aksine düşük derişimlerde (27,8 mM) glukoz uygulamalarının ABA sentezini uyarmadığı ve buna bağlı olarak da çimlenmeyi baskılamadığı belirlenmiştir. ABA'nın şekerle, lipit ve protein gibi tohum depo kaynaklarının birikimini ve metabolizmasını engellediğini de rapor edilmiştir (Jang ve Sheen, 1997; Garcarrubio vd., 1997; Finkelstein ve Lynch, 2000; To vd., 2002; Price vd., 2003; Rolland vd., 2006; Dekkers ve Smeekens, 2007). Jang vd. (1997) ise 110 mM'dan düşük derişimlerdeki glukoz miktarının çimlenmeyi etkilediğini ve hipokotil uzunluğu ile glukoz miktarı arasında negatif bir ilişki olduğunu ortaya koymuştur. Fruktoz, glukoz gibi nişasta sentezinde rol oynayan bir bileşiktir. Ayrıca, fotosentezde fikse edilen her bir karbonun kloroplastlarda nişastaya mı yoksa sitozolde sukroza mı dönüştürüleceği fruktoz tarafından kontrol edilmektedir. Eğer sitozolde fruktoz miktarı yüksek ise sukroz içeriği düşüktür (Huber, 1986; Schulz, 1994; Huber ve Huber, 1996; Barker vd., 2000; Nielsen vd., 2004; Minchin ve Lacomte, 2005; Stitt, 2007; Hammond ve White, 2008). Yürütülen bu çalışmada, fruktoz miktarı 200 mT'de 20 dk ve 400 mT'de 60 dk süreyle olan uygulamalarında negatif olarak belirlenmiştir. Ayrıca, 400 mT'de 20 dk ve 200 mT'de 60 ve 120 dk olarak verilen MA uygulamalarında ise fruktoz içeriği kontrol ve diğer uygulamalara göre yüksek bulunmuştur (Çizelge 1, Şekil 3). Fruktoz miktarının yüksek olduğu uygulama gruplarında sukroz içeriğinin düşük, nişasta içeriğinin yüksek olması yukarıda adı geçen araştırmacıların (Hammond ve White 2008; Geigenberg vd., 2002; Huber ve Huber, 1996) çalışmalarıyla ile uygunluk göstermektedir.

Sukroz, glukoz ve fruktoz moleküllerinin kondenzasyonu (dehidrasyonu) ile sentezlenen, fotosentez, solunum, çimlenme olayları ve hücre içi ozmotik basıncın düzenlenmesinde rol oynayan önemli bir bileşiktir (Kimberly, 1998; Francisco Arenas-Huertero, 2000; Rita vd., 2005; Pintilie vd., 2006; Atak vd., 2007). Bu çalışmada; sukroz içeriği 200 mT'de 120 dk ve 400 mT'de 60 dk düşük, 200 mT'de 120 dk ve 400 mT'de 20 dk uygulamalarında yüksek derişimlerde bulunmuştur. Nişastanın içeriğinin düşük olduğu derişimlerde glukoz ve sukroz içeriği değerlerinin düşük, fruktoz içeriği değerlerinin ise yüksek olması ise, nişastanın enzimatik parçalanma sürecinin yavaş ilerlemesinde kaynaklanmış olabilir. Nişastanın parçalanmasından  $\alpha$ -amilaz, lipitlerin yıkımından ise lipazlar sorumludur. Lipitlerin önce yağ asitlerine sonra da sukroza dönüşmesi farklı enzimlerle kontrol edilmektedir (Lin vd., 1983; Rahamatalla vd., 2001; To vd., 2002). Kayın tohumlarında yağların yıkımından sorumlu lipaz enziminin MA uygulamasından olumsuz etkilenmesi sukroz miktarının düşük olmasında katkısı olabilir. Ayrıca, 200 mT'de 20 dk MA uygulamasının tohum nişasta içeriği değerini diğer uygulama ve kontrol grubuna göre negatif göstermiştir. Bunun yanında diğer uygulamalarda nişasta içeriği değerleri kontrol grubuna göre yüksek bulunmuştur. Bu sonuç glukoz, fruktoz ve sukroz içeriğindeki değişiminden kaynaklanmaktadır. Nişasta, glukoz ve fruktoz monomerlerinden sentezlenmektedir. Bu nedenle çalışmada glikoz konsantrasyonunun düşük olduğu uygulamalarda nişasta içeriği düşük, fruktoz konsantrasyonunun yüksek olduğu uygulamalarda ise yüksek çıkmaktadır. Çünkü çimlenmenin erken safhalarında solunum hızının artması, nişastanın ve sukrozun yıkımını uyardmakta ve böylelikle glikoz ve fruktoz birikimine neden olmaktadır (Krugger, 1997; Bewley ve Black, 1994; Bewley, 1997; Finscher, 1989).

$\alpha$ -Amilaz, nişasta moleküllerini basit şekerlere kadar parçalayan enzimdir (Bewley, 2001; Rita vd., 2005; Xu vd., 2010). Vanisth ve Nagaraja (2010), mısır tohumlarının suyun almasıyla birlikte  $\alpha$ -amilaz enzim aktivitesini uyarıldığını ve uyarımın nişastanın daha basit şekerlere parçalandığını rapor etmişlerdir. Palmiano ve Juliano (1972), pirinç bitkisi tohumlarında  $\alpha$ - ve  $\beta$ -amilaz enzimi aktivitelerinin çimlenme esnasında arttığını ve bu artışla birlikte mevcut nişastanın büyük çoğunluğunun glukoz, az bir kısmının ise maltoz gibi indirgen şekerlere ve sukroz gibi indirgen olmayan şekerlere parçalandığını belirlemişlerdir. Nomura vd., (1969) ise endospermdeki glukozun skutelluma taşınarak orada sukroza dönüştürüldüğünü belirtmişlerdir. MA uygulamalarının, tohumlardaki  $\alpha$ -amilaz ve diğer hidrolitik enzimlerin aktivitelerini uyardığı birçok araştırmacı tarafından rapor edilmiştir (Palmiano ve Juliano, 1972; Pintilie vd., 2006; Atak vd., 2007; Vashist ve Nagarajan, 2010; Pourakbar ve Hatami, 2012). Oysa mevcut çalışmada, kontrol grubundaki tohumlarının  $\alpha$ -amilaz enzimi aktivitesinin diğer tüm uygulamalara kıyasla daha yüksek olduğu tespit edilmiştir. Kontrol grubu ile karşılaştırıldığında, 200 mT'de 60 dk ve 400 mT'de 120 dk yapılan MA uygulamasının  $\alpha$ -amilaz enzimi aktivitesi değerleri sırasıyla 3,8 ve 3 kat daha az bulunmuştur (Çizelge 1, Şekil 2,  $P<0.05$ ). Çalışmada  $\alpha$ -amilaz aktivitesi sonuçları bu alanda yapılan diğer çalışma verileri ile uygunluk göstermektedir. Tohumların  $\alpha$ -amilaz aktivitesi düşüklüğü, MA'nın bir abiyotik faktör olarak olumsuz etkisinden ve tohumun farklı kimyasal içeriğinden kaynaklanabilir (dormansi durumu, su içeriği, hasat durumu, nişastanın polimerizasyon durumu vb.). Bununla birlikte, farklı hasat yılları, değişik saklama koşulları ve popülasyonlara ait tohumlarla gerçekleştirilecek ileri çalışmalar ile Doğu kayını tohumlarında manyetik alan uygulamalarının etkilerinin belirlenmesine yönelik daha kesin ve açıklayıcı sonuçlar sağlanabilecektir.

## Tesekkür

Katkılardan dolayı Karadeniz Teknik Üniversitesi Biyoloji Bölümü öğretim üyesi Prof. Dr. Ahmet Faik AYAZ ve Erzincan Üniversitesi Biyomedikal Mühendisliği öğretim üyesi Yrd. Doç. Dr. Ayşe AK'a şükranlarımızı sunarız. Proje dışı bir çalışma olarak yürütülen ve hazırlanan bu makale, KÜBAP-01/2013-17, KÜBAP-01/2013-59 ve KÜBAP-01/2014-21 projelerinin imkanları kullanılarak yürütülmüştür.

## Kaynaklar

- Agustrina, R., T. T. Handayani, S. Wahyuningsih, dan O. Prasetya. 2012. Pertumbuhan Tanaman Tomat (*Lycopersicon esculentum* Mill.) di Bawah Perlakuan Medan Magnet 0,2 mT. In the Proceedings of the 2012. SNSMAIP III, pp: 277-281.
- Ak, A., Yücel, E., Ayan, S. 2012. Relationship between Seed Germination and Catalase Enzyme Activity of *Abies* taxa from Turkey, Kastamonu Univ., Journal of Forestry Faculty, 12 (3) Special Issue; 185-188.
- Aladadjijyan, A., Teodora, Y. 2003. Influence of stationary magnetic field on the early stages of the development of tobacco seeds (*Nicotiana tabacum* L.). Journal Central European Agriculture. Vol. 4. No. 2. p131-137.
- Amaya, J.M., Carbonell, M.V., Martinez, E. & Raya, A. 1996. Effects of stationary magnetic fields on germination and growth of seeds. Hort. Abst. 68, 1363.
- Anonim, 2006. Orman Varlığımız, Çevre ve Orman Bakanlığı, Orman Genel Müdürlüğü, OGM Matbaası, Ankara, Mart 2006, 152 pp.
- Arenas-Huertero, F., Arroyo, A., Zhou, L., Sheen, J., León, P. 2000. Analysis of *Arabidopsis* glucose insensitive mutants, *gin5* and *gin6*, reveals a central role of the plant hormone ABA in the regulation of plant vegetative development by sugar, Genes Dev. 2000 Aug 15; 14(16): 2085–2096.
- Atak, C., Celik, O., Olgun A., Alikamanoglu, S., Rzakoulieva, A. 2007. Effect of Agnetic Field on Peroxidase Activities of Soybean Tissue Culture. Biotechnol. & Biotechnol. EQ. 21 (2): 166-171.
- Atalay, İ. 1992. Kayın (*Fagus orientalis* Lipsky.) Ormanlarının Ekolojisi ve Tohum Transferi Yönünden Bölgelere Ayrılması. Orman Bakanlığı, Orman Ağaçları ve Tohumları Islah Araştırma Müdürlüğü, Yayın No: 5, Ankara, 209 s.
- Atay, İ. 1987. Doğal Gençleştirme Yöntemleri I-II, İ.Ü Fen Bilimleri Enstitüsü, İ.Ü Yayın No: 3461, F.B.E Yayın No: 1, İstanbul, 290 s.
- Ayaz, F. A., Glew, R. H., Turna, I., Güney, D., Chuang, L. T., Chang, Y.C., Andrews, R., Power, L., Presley, J., Torun, H., Sahin, N. 2011. *Fagus orientalis* (Oriental beechnut) seeds are a good source of essential fatty acids, amino acids and minerals. Food 5: 48–51.
- Barker, L., Kuehn, G., Weise, A., Schulz, A., Gebhart, C., Hirner, B., Hellman, H., Schulze, W., Ward, J. M. and Frommer, W. B. 2000. SUT2, a putative sucrose sensor in sieve elements. Plant Cell., 12:1153-1164.
- Bewley, J.D. 1997. Seed germination and dormancy. Plant Cell, 9,1055±1066.
- Bewley, J.D., Black, M. 1994. Seeds: Physiology of Development and Germination. 2nd edn. New York, NY:Plenum.
- Bewley, J.D. 2001. Seed Germination and Reserve Mobilization. J Derek Bewley, University of Guelph, Guelph, Ontario, Canada. Encyclopedia of Life Sciences & 2001 Nature Publishing Group / [www.els.net](http://www.els.net).
- Bradford, M.M. 1976. Rapid and sensitive method for the quantitation of microgram quantities of protein utilizing the principle of protein-dye binding, Anal. Biochem. 72: 248-254, doi:10.1016/0003-2697(76) 90527-3.
- Criveanu, H.R., Taralunga, G. 2006. Influence of magnetic fields of variable intensity on behaviour of some medicinal plants. Journal of Central European Agricultura. Vol 7 (4): 643-648.
- Danilov, V., Bas, T., Eltez, M. & Rizakulyeva, A. 1994. Artificial magnetic field effects on yield and quality of tomatoes. Acta Hort.366, 279-285.
- De Souza, A., Garcı, D., Sueiro, L., Gilart, F., Porras, E., Licea, L. 2006. Pre-sowing magnetic treatments of tomato seeds increase the growth and yield of plants. Bioelectromag 27:247-257.
- De Souza, A., D. Garcıa, L. Sueiro, L. Licea, Porras, E. 2005. Pre-sowing magnetic treatment of tomato Seeds: effects on the growth and yield of plants cultivated late in the season. Spanish Journal of Agricultural Research. 3(1), 113-122.
- Debeaujon, I., Koornneef, M. 2000. Gibberellin requirement for *Arabidopsis* seed germination is determined both by testa characteristics and by embryonic abscisic acid. Plant Physiol. 122, 415±424.
- Dekkers, B. J. W., Schuurmans, A. M. J., Smeekens, S. C. M. 2004. Glucose delays seed germination in *Arabidopsis thaliana*. Planta V218:579-588.
- Dekkers, B.J. W., Smeekens, S. 2007. Sugar and abscisic acid regulation of germination and transition to seedling growth. In: Bradford K, Nonogaki H (eds) Seed development, dormancy and germination. Blackwell Publishing, Oxford, UK.
- Dennis, D. T., and Blakeley, S. D. 2000. Carbohydrate metabolism. In Biochemistry and Molecular Biology of Plants, B. Buchanan, Wgruis-sem and R Jones (eds) American Society of Plant Physiologist, Rockville MD, PP:630-674.
- Dhawi, F., Al-Khayri, J.M., & Hassan, E. 2009. Static magnetic field influence on elements composition in date palm (*Phoenix dactylifera* L.). Res J Agric Biol Sci 5,161-166.
- Dornbos, D. L., Mullen, R. E. 1992. Soybean seed protein and oil concentration and fatty-acid composition adjustments by drought and temperature. J. Am. Oil Chem. Soc. 69, 228–231.
- Dunlop, D.W., Schmidt, B.L. 1965. Biomagnetics II. Anomalies found in the root of *Allium cepa* L. Hort. Abst. 36, 563.
- Ertekin, M., Kırdar, E., Ayan, S. 2015. Effects of tree ages, exposures and elevations on some seed characteristics of Oriental beech (*Fagus orientalis* Lipsky.). SEEFOR - South-east European Forestry, 6 (1) 15-23.
- Eşitken, A. 2002. Serada yetiştirilen çilekte manyetik alan uygulamasının etkileri, Atatürk Üniversitesi Ziraat Fakültesi Dergisi, 34 (1): 25-27.
- Eşitken, P.E. 2006. Elektromagnetik Alanın Lens *Culinaris medik* (Mercimek) Üzerinde Sitotoksik Etkileri, Marmara Üniversitesi, Fen Bilimleri Enstitüsü, Yüksek Lisans Tezi.

- Finkelstein, R.R., Lynch, T.J. 2000. Abscisic acid inhibition of radicle emergence but not seedling growth is suppressed by sugars. *Plant Physiol* 122:1179-1186.
- Fincher, G.B. 1989. Molecular and cellular biology associated with endosperm mobilization in germinating cereal grains. *Annu Rev Plant Physiol Plant Mol Biol* 40: 305-346.
- Florez, M., Carbonell, M.V., Martinez, E. 2007. Exposure of maize seeds to stationary magnetic fields: Effects on germination and early growth. *Environ Exp Botany* 59:68-75.
- Francisco Arenas-Huertero, A. A., Zhou, L., Sheen, J., León, P. 2000. Analysis of *Arabidopsis* glucose insensitive mutants, gin5 and gin6, reveals a central role of the plant hormone ABA in the regulation of plant vegetative development by sugar. *Genes Dev*, 14 (16), 2085-2096.
- Garcia, F., Arze, L. I. 2001. Influence of a stationary magnetic field on water relations in lettuce seeds. Part I: Theoretical considerations, *Bioelectromagnetics*, Vol. 22, No. 8, pp. 589-595.
- Garcia, I.S., Souza, A., Barbedo, C.J., Dietrich, S.M., Figueiredo-Ribeiro, R.C.L. 2006. Changes in soluble carbohydrates during storage of *Caesalpinia echinata* LAM. (Brazilwood) seeds, an endangered leguminous tree from the Brazilian Atlantic Forest. *Braz. J. Biol.* 66: 739-745.
- Garcarrubio, A., Legaria, J.P., Covarrubias, A.A. 1997. Abscisic acid inhibits germination of mature *Arabidopsis* seeds by limiting the availability of energy and nutrients. *Planta* 203: 182–187.
- Geigenberger, P., Kolbe, A., Tiessen, A. 2005. Redox regulation of carbon storage and partitioning in response to light and sugars. *J Exp Bot*, 56: 1469-1479.
- Gezer, A., Yücedağ, C. 2006. Forest tree seeds and techniques of seedling propagation from seed originated. Suleyman Demirel University, Faculty of Forestry, Pub. No: 56, Isparta, Turkey, 140 p.
- Gibson, S.I. 2005. Control of plant development and gene expression by sugar signaling. *Curr. Opin. Plant Biol.* 8:93 – 102 .
- Guglielminetti, L., Busilacchi, H.A., Alpi, A. 2000. Effect of anoxia on  $\alpha$ -amylase induction in maize caryopsis. *J. Plant Res.*, 113:185-92.
- Güney, D., Bak, Z. D., Aydınoğlu, F., Turna, İ., Ayaz, F. A. 2013. Effect of geographical variation on the sugar composition of the oriental beech (*Fagus orientalis* Lipsky). *Turk J Agric For*: 7: 221-230.
- Hamilton J.G., Zangerl A.R., Delucia E.H., Berenbaum, M.H. 2001. The carbon-nutrient balance hypothesis: Its rise and Fall. *Ecology Letters* 4: 86-95.
- Hammond, J.P., White, P. J. 2008. Sucrose transport in the phloem. Integrating root responses to phosphorus starvation. *Journal Experimental Botany* 59:109-113.
- Holdsworth, M., Kurup, S., McKibbin, R. 1999. Molecular and genetic mechanisms regulating the transition from embryo development to germination. *Trends Plant Sci.* 4, 275±280.
- Huber, S. C. 1986. Fructose 2,6 biphosphate as a regulatory metabolites in plants. *Annu. Rev. Plant. Physiol. Plant Mol Biol.* 37:233-246.
- Huber, S. C., Huber, J. L. 1996. Role and regulation of sucrose-phosphate synthase in higher plants. *Annu. Rev. Plant. Physiol. Plant Mol Biol.* 47:431-444.
- Jang, J. C., Leon, P., Zhou, L., Sheen, J. 1997. Hexokinase as a sugar sensor in higher plants. *Plant Cell* 9: 5-19.
- Jang, J. C., Sheen, J. 1997. Sugar sensing in higher plants. *Trends Plant Sci* 2:208-214.
- Kaneko, M. Itoh H, Ueguchi-Tanaka M, Ashikari M, Matsuoka M. 2002. The  $\alpha$ - amylase induction in Endosperm during Rice Seed Germination Is Caused by Gibberellin Synthesized in Ephithelium. *Plant Physiology*. 168: 1264-1270.
- Kimberly, L., Falk, R.H.B., Chengbin Xiang, David J. O. 1998. Metabolic Bypass of the Tricarboxylic Acid Cycle during Lipid Mobilization in Germinating Oilseeds. *Plant Physiology*, 117, 473-481.
- Komnink, E., Kruger, N.J. 1984. Inhibition by metabolic intermediates of pyrophosphate: fructose 6-phosphate phosphotransferase from germinating castor bean endosperm. *Z Pflanzenphysiol* 114, 443-453.
- Kruger, R. 1997. Carbohydrate synthesis and degradation. *In Plant Metabolism*, 2<sup>nd</sup> ed, DT Dennis, Turpin D.H., Lefebvre D.D., Layzell D.B., Longman, Singapore, pp:83-104.
- Lebedev, S.I., Baranskil, P.I., Litrimenko, L.G., Shiyani, L.T. 1975. Physiobiochemical characteristics of plants after presowing treatment with a permanent magnetic field. *Soviet Plant Physiology*. 22. 84–89.
- Levin, M., Ernst, S. G. 1997. Applied DC magnetic fields cause alterations in the time of cell divisions and developmental abnormalities in early sea urchin embryos. *Bioelectromagnetics* 18:255–263.
- Lin, Y. H., Wimer, L. T., Huang, A.H.C. 1983. Lipase in the lipid bodies of corn scutella during seedling growth. *Plant Physiol* 73: 460- 463.
- Magnusson, M. 1984. Magnetic treatment of the nutrient solution for tomatoes and the influence of a magnetic field on water and plants. *Rapport Ins For Tradgardsvetenskap, Sveriges, Lant Bruksuniversite*, 30: 42.
- Matsuda, T., Asou, H., Kobayashi, M., Yonekura, M. 1993. Influences of magnetic fields on growth and fruit production of strawberry. *Acta Hort.* 348, 378-380.
- Minchin, P.E., Lacoite, A. 2005. New understanding of phloem physiology and possible consequences for modelling long-distance carbon transport. *New Phytologist* 166:771-779.
- Namba, K. 1996. Effects of alternating magnetic field on plant growth. *Sci. Reports Fac. Agric. Okayama Univ.* 85, 115-117.
- Namba, K., Mohri, M., Sasao, S., Shibusawa, S. 1998. Effects of impulse electromagnetic field on plant germination. *ASAE Annual International Meeting*, Orlando, Florida, USA, 12-16 July.
- Namba, K., Sasao, A., Shibusawa, S. 1995. Effect of magnetic field on germination and plant growth. *Acta Hort* 399:143–145.
- Nielsen, T. H., Rung, J.H., Villadsen, D. 2004. Fructose 2,6-bisphosphate: A traffic signal in plant metabolism. *Trends in Plant Science* 9:556-563.
- Nomura, T., Kono, Y., Akazawa, T. 1969. Enzymic mechanism of starch breakdown in germinating rice seeds. II. Scutellum as the site of sucrose synthesis. *Plant Physiology* 44, 765-769.
- Novitsky, Y.I., Novitskaya, G.V., Kocheshkova, T.K., Nechiporenko, G.A., Dobrovolskii, M.V. 2001. Growth of green onions in a weak permanent magnetic field. *Russian Journal of Plant Physiology*. 8:709-716.

- Palmiano, E. P., Juliano, B. O. 1972. Biochemical changes in the rice grain during germination. *Plant Physiology* 49, 751–756.
- Pearson, D., Melon, H.K., Ronald, S. 1976. *Chemical analysis of Food*, 8th edition. Churchill Livingstone. Pp 5-63.
- Phirke, P.S., Kubde, A. B., Umbarkar, S. P. 1996. The influence of magnetic field on plant growth. *Seed Sci Technol* 24:375-392.
- Pintilie, M., Oprica, L., Surleac, M., Dragutivan, S., Creanga, D.E. 2006. Enzyme Activity in Plants Treated with magnetic solution. *Rom. Journ. Phys.*, Vol. 51, Nos. 1–2, P. 239-244.
- Plaxton, W. C. 1996. The organisation and regulation of plant glycolysis. *Annu. Rev. Plant Physiol. Plant Mol. Biol.* Pp:47:185-214.
- Podlesny, J., Misiak, L.E., Podlesna, A., Pietruszewski, S. 2005. Concentration of free radicals in pea seeds after pre-sowing treatment with magnetic field. *International Agrophysics*. Vol 19. No.3. pp 243-249.
- Porch, T. G. 2006. Application of stress indices for heat tolerance screening of common bean. *J. Agron. Crop Sci.* 192, 390–394.
- Pourakbar, L. 2013. Effect of Static Magnetic Field on Germination, Growth Characteristics and Activities of Some Enzymes in Chamomile Seeds (*Matricaria chamomilla* L.). *International Journal of Agronomy and Plant Production*. Vol., 4 (9), 2335-2340.
- Pourakbar, L., Hatami, S. 2012. Exposure of *Satureia hortensis* L. Seeds to Magnetic Fields: Effect on Germination Growth characteristic, and activity of Some enzymes. *Journal of Stress Physiology & Biochemistry*. Vol 8. No. 21: 191-198.
- Prasad, P. V. V., Boote, K. J., Allen, Jr, L. H., and Thomas, J. M. G. 2002. Effects of elevated temperature and carbon dioxide on seed-set and yield of kidney bean (*Phaseolus vulgaris* L.). *Global Change Biol.* 8, 710–721.
- Prasad, P. V. V., Craufurd, P. Q., and Summerfield, R. J. 2000. Effect of high air and soil temperature on dry matter production, pod yield and yield components of groundnut. *Plant Soil* 222, 231–239.
- Price, J., Li, T.C., Kang, S. G., Na, J. K., Jang, J.C. 2003. Mechanisms of glucose signaling during germination of *Arabidopsis*. *Plant Physiol.* 132 : 1424 – 1438.
- Rahamatalla, A.B., Babiker, E.E., Krishna, A.G. 2001. Changes in fatty acids composition during seed growth and physicochemical characteristics of oil extracted from four safflower cultivars. *Plant Foods Human Nut* 56: 385-395, 2001.
- Rezaei, A., Nasery, B., Yazdian, F., Mhedayati, Ma. 2011. A study of gibberalic acid effect on oriental beech (*Fagus orientalis* L.) nuts dormancy removal. In: Wagner S, Fahlvik N, Fischer H (eds) *Proceedings of The 9th IUFRO International Beech Symposium organized by IUFRO working party 1.01.07 “Ecology and Silviculture of Beech” Dresden/Göttingen, Germany, 12-17 September 2011*. Institute for Silviculture and Forest Protection, Dresden, Germany, pp 61-63.
- Rita T. T., Knorpp, C., Glimelius, K. 2005. Modified sucrose, starch, and ATP levels in two alloplasmic male-sterile lines of *B. napus*. *Journal of Experimental Botany*, 56(414), 1245–1253.
- Rochalska M, Orzeszko-Rywka, A. 2005. Magnetic field treatment improves seed performance. *Seed Sci Technol* 33:669-674.
- Rolland, F., Baena-Gonzalez, E., Sheen, J. 2006. Sugar sensing and signaling in plants: Conserved and novel mechanisms. *Annu Rev Plant Biol* 57:675-709.
- Roper, T.R., J.D. Keller, W.H. Loescher, Rom, C.R. 1988. Photosynthesis and carbohydrate partitioning in sweet cherry: Fruiting effects. *Physiol. Plant.* 72:42-47.
- Saatçioğlu, F. 1969. *Silvikültürün Biyolojik Esasları ve Prensipleri*. İ.Ü Orman Fakültesi, İ.Ü Yayın No: 1429, O.F Yayın No: 138, İstanbul, 323 s.
- Samy, C.G. 1998. Magnetic seed treatment. I. Influence on flowering, siliquae and seed characteristics of cauliflower. *Orissa J. Hort.* 26, 68-69.
- Schulz, A. 1994. Phloem transport and differential unloading in pea seedlings fluorescence microscopy. *Protoplasma*, 166:153-164.
- Stange, B. C., Rowland, R. E., Rapley, B. I., Podd, J. V. 2002. ELF magnetic fields increase amino acid uptake into *Vicia faba* L. roots and alter ion movement across the plasma membrane. *Bioelectromagnetics* 23:347–354.
- Stitt, M., Gibon, Y., Lunn, J. E., Piques, M. 2007. Multilevel genomics analysis of carbon signalling during low carbon availability: Coordinating the supply and utilisation of carbon in a fluctuating environment. *Funct Plant Biol* 34:526-549.
- Subbarao, K.V., Datta, R. and Sharma, R. 1988. Amylases synthesis in scutellum and aleurone layer of maize seeds. *Phytochemistry*, 49:657- 666.
- To, J.P., Reiter, W.D., Gibson, S. I. 2002. Mobilization of seed storage lipid by *Arabidopsis* seedlings is retarded in the presence of exogenous sugars. *BMC Plant Biol* 2: 4.
- Torres, S, Porrás Leon, E., Fernández C., R. 1999. Effects of magnetic treatment of tomato (*Lycopersicon esculentum* Mill) seeds on germination and seedling growth. *Hort. Abst.* 70, 68-92.
- Vashisth, A., Nagarajan; S. 2010. Characterization of Water distribution and Activities of Enzymes during Germination in Magnetically-exposed Maize (*Zea mays* L.) Seeds. *Indian Journal of Biochemistry and Biophysics*. Vol 47. pp. 311-38.
- Winter, H., Huber, S. C. 2000. Regulation of Sucrose Metabolism in Higher Plants: Localisation and Regulation of Activity of Key Enzymes. *Critical Review Plants Sciences* 19:31-67.
- Xu, F., Tan, X., Wang, Z. 2010. Effects of Sucrose on Germination and Seedling Development of Brassica Napus. *International Journal of Biology*. 2(1).
- Yılmaz, M. 2005. The researches on the physiology of oriental beech (*Fagus orientalis* Lipsky.) seeds. PhD thesis, Istanbul University, Faculty of Forestry, Istanbul, Turkey, 170 p.
- Zeaaman, S.C., Smith, S.M., Smith, A.M. 2007. The diurnal metabolism of leaf starch. *Biochemical Journal* 401:13-28.
- Zimmermann, M. H., Ziegler, H. 1975. List of sugars and sugar alcohols in sieve-tube exudates. In (Zimmermann MH., Milburn., JA (eds) *Encyclopedia of plant physiology*, Springer Verlag, Hridelberg, Vol, 1, 480-503.

(Received for publication 27 April 2016; The date of publication 15 August 2016)



## Identification and bioinformatics analyzes of heat shock protein 70 genes (Hsp 70) in *Fagaceae* family

Esra Nurten YER<sup>1</sup>, Mehmet Cengiz BALOĞLU<sup>2</sup>, Yasemin ÇELİK ALTUNOĞLU<sup>2</sup>, Sezgin AYAN<sup>\*1</sup>

<sup>1</sup>Kastamonu Üniversitesi, Orman Fakültesi, Silvikültür ABD, 37100-Kastamonu, Türkiye

<sup>2</sup>Kastamonu Üniversitesi, Mühendislik Mimarlık Fak., Genetik ve Biyomühendislik Böl., 37150, Kastamonu, Turkey

### Abstract

Heat shock proteins (Hsps) are a group of proteins found in all living organisms. They play key roles in regulating the stress response to salinity, drought, and extreme temperature changes in plants. Hsps also act as molecular chaperones that provide favorable conditions for the correct folding of other proteins, thus preventing protein aggregation. Many studies have been performed to identify molecular functions of individual family members. However, there is a limited study on genome-wide identification and characterizations of Hsp70s in *Fagaceae* family (American beech, American chestnut, Chinese chestnut, European chestnut, Japanese chestnut, Oak, Red oak and White oak). In this study, we have identified 13, 17 and 15 *Hsp70* genes in beech, oak and chestnut, respectively. Phylogenetic, conserved motifs and 3D protein structure analysis of identified *Hsp70* genes were also performed. According to phylogenetic analysis, *Hsp70* genes could be classified into different groups. Specific motifs were found in all predicted Hsp70 proteins and were relatively conserved in beech, oak and chestnut genomes. The protein 3D structure of a total of thirteen Hsp70s “(FagHsp70-03(68%) / FagHsp70-08(65%) / FagHsp70-09(71%) / FagHsp70-13(80%) / QuerHsp70-03(65%) / QuerHsp70-04(68%) / QuerHsp70-09(71%) / QuerHsp70-14(77%) / CasHsp70-03(65%) / CasHsp70-04(67%) / CasHsp70-11(65%) / CasHsp70-14(65%) / CasHsp70-15(61%)” were modelled at > 90% confidence and the percentage residue varied from 65 to 80. These results provide characterization and functional information of Hsp70 proteins for *Fagaceae* family. This genome-wide identification will enable researcher to open new perspectives for further studies to improve stress tolerant forest trees.

**Key words:** bioinformatics analysis, heat shock protein, *Fagaceae*, genome-wide identification

----- \* -----

### *Fagaceae* familyasında ısı şoku protein 70 gen ailesinin (Hsp70) tanımlanması ve bioinformatik analizleri

### Özet

Isı şoku proteinleri (Hsps: Heat Shock Proteins), canlı organizmalarda bulunan bir grup protein ailesidir. Isı şoku protein genleri stres anında örneğin tuzluluk, kuraklık ve ekstrem sıcaklık değişimlerinin düzenlenmesinde anahtar bir rol üstlenmektedirler. Bu proteinler hücrel şaperonlar gibi fonksiyon görürler, protein sentezinde proteinlerin doğru katlanmasında ve taşınmasında rol oynarlar. *Hsp70* gen ailesinin moleküler işlevlerine ait bazı çalışmalar yapılmıştır. Fakat *Fagaceae* familyası (Amerikan kayını, Amerikan kestanesi, Çin kestanesi, Avrupa kestanesi, Japon kestanesi, Meşe, Kırmızı meşe ve Ak meşe) *Hsp70* gen ailesinin genom analizi ve gen karakterizasyonuna ait sınırlı çalışma mevcuttur. Bu çalışmada Tanımlanan *Hsp70* gen ailesi dizilerinin genomdaki dağılımları, korunmuş motiflerinin tanımlanması ve tahmini üç boyutlu protein yapılarının belirlenmesi hedeflenmiştir. *Hsp70* gen ailesine ait Kayın, Meşe ve Kestane’de sırasıyla 13, 17 ve 15 gen tanımlanmıştır. Filogenetik analiz sonucuna göre *Hsp70* genleri 3 farklı grup oluşturmuştur. Yapılan motif analizine göre Hsp70 proteinlerinin genom içerisinde (kayın, meşe ve kestanede) nispeten korunduğu görülmüştür. Proteinlerin üç boyutlu modellemesi yapıldığında toplam *Fagaceae* familyasına ait 13 *Hsp70* geni >90% güven düzeyinde test edilmiştir. Bu on üç protein “(FagHsp70-03(%68) / FagHsp70-08(%65) / FagHsp70-09(%71) / FagHsp70-13(%80) / QuerHsp70-03(%65) / QuerHsp70-04(%68) / QuerHsp70-09(%71) / QuerHsp70-14(%77) / CasHsp70-03(%65) / CasHsp70-04(%67) / CasHsp70-11(%65) / CasHsp70-14(%65) / CasHsp70-15(%61)” data bankta bulunan proteinlerle yaklaşık %65-%80 arasında üç boyutlu

\* Corresponding author / Haberleşmeden sorumlu yazar: Tel.: +903662801010; Fax.: +903662152316; E-mail: sezginayan@kastamonu.edu.tr

homoloji modellemesi göstermiştir. Bu sonuçlar *Fagaceae* familyasında *Hsp70* gen ailesinin karakterizasyonu ve fonksiyonel işlevleri hakkında bilgi sağlamaktadır. Bu çalışma ile bitkilerde stres toleransının geliştirilmesine ait birçok araştırma için yeni bir perspektif sağlanacaktır.

**Anahtar kelimeler:** biyoinformatik analizler, ısı şoku proteinleri, *Fagaceae* familyası, Genom analizi

## 1. Giriş

Isı şoku proteinlerini kodlayan genlerin bulunduğu gen ailelerinin evrim sürecinde fonksiyon ve yapı bakımından en fazla korunmuş gen ailesi olduğu bilinmektedir (Sorensen ve ark., 2004). Bu grup proteinlere ısı şoku proteinleri (Heat shock protein; Hsp), stres proteinleri, şaperon gibi farklı isimler verilmiştir ve molekül ağırlıklarına göre sınıflandırılmışlardır. Bu proteinler bütün prokaryot ve ökaryotlarda korunmuştur (Liberek ve ark., 2008). Ayrıca bu proteinler bir kalıp görevi görerek sentez sırasında veya sentezden hemen sonra proteinlerin doğru katlanmalarını sağlamaktadır.

Hsp70 evrim süresince korunmuş olan en önemli stres uyarımlı proteindir. Hücredeki sentezi en fazla yüksek ısı ve ağır metal etkisinde artmaktadır. Hsp70 ilk olarak Ritossa adlı araştırmacı tarafından 1962 yılında *Drosophila melanogaster* (Sirke sineği) tükrük bezi hücrelerinde tanımlanmıştır. Yüksek bitkiler birçok çevresel stresle karşı karşıya kalırlar. Hiperterm stres bitkinin büyüme ve gelişimini olumsuz etkileyen bazı morfolojik, fizyolojik, biyokimyasal ve moleküler değişikliklere sebep olmaktadır. Bitkiler yüksek sıcaklık stresine cevap olarak Hsp proteinlerini sentezler (Ritossa, 1996).

Sentezlenen protein zincirini oluşturan polipeptid zinciri ribozomun dar yapısı nedeniyle ribozomun içinde katlanamaz. Ancak 50-300 aminoasitlik zincir ribozomdan tamamen çıktıktan sonra katlanabilir hale gelir. Oluşan protein zincirine bağlanan Hsp'ler (trigger faktör, Hsp70, prefoldin) ribozomdan uzayarak sentezlenen zincirleri düzgünce stabilize ederler. In vitro ortamda küçük proteinler kendiliğinden katlanırken büyük proteinler kısmen veya hatalı katlanırlar ve genelde çökme eğilimi gösterirler. Sitozolün yoğun yapısı doğal olmayan zincirin agregasyonunu arttırarak makromoleküler yığılma adı verilen durumu oluşturur. Makromoleküler yığılma, katlanma sırasında zincirin büzüşmesi ve doğal olmayan zincir-şaperon etkileşimini ortaya çıkarır (Thomas ve ark., 2005). Tüm türlerde mitokondrial Hsp 70 proteinleri normal koşullarda belirlenmiştir ve bu nedenle, zorunlu bir protein olduğu düşünülmektedir. Kontrol ve stres koşulları altında agregasyonun önlenmesi ve doğal yapısı bozulmuş proteinlerin tekrar katlanmasında zorunlu fonksiyon üstlenmiştir (Frydman, 2001). Hsp 70 proteinlerinin birkaç üyesi, katlanmış regülatör proteinlerin biyolojik aktivitesinin kontrolünü sağlamakta ve transkripsiyon ile ilgili sıcaklık şoku faktörünün negatif baskılayıcı olarak fonksiyon gösterebilmektedir (Hartl, 1996; Morimoto, 1998). Hsp 70 proteinlerinin ATP hidrolizi ve protein katlanmasını kolaylaştırdığı, hiperterm stresi sırasında denatüre olan proteinlere bağlandığı ve öncül ribozomları denatürasyondan koruduğu ileri sürülmüştür (Pelham, 1986).

*Fagaceae* familyası içerisinde yer alan; Kayın (*Fagus*), Türkiye'de Doğu kayını (*Fagus orientalis* Lipsky.) ve Avrupa kayını (*Fagus sylvatica* L.) olmak üzere iki türle temsil edilmektedir. Fakat ülkemizde esas yayılışı Doğu kayını yapmaktadır (Atalay, 1992). Doğu Kayını, Mayr'ın Orman basamaklarına göre, Castanetum zonunun serin basamağı (250-500 m) ile Fagetum zonu içerisinde (500-1000 m) yer almaktadır. Ancak, yetişme ortamlarına göre 150 m'ye kadar inip (Akçakoca), 2000 m'ye kadar çıkabilen (Simav) bir türdür (Atay, 1982a). Doğu Kayını ağırlıklı olarak kuzey ve kuzey-batı bakılarda karşımıza çıkmaktadır. Drenajı iyi yerlerden hoşlanması ve durgun sudan kaçması sebebiyle çok eğimli ve dik yamaçları tercih etmektedir. Bu tip sahalarda da genellikle orta ve üst yamaçlarda bulunmaktadır. Doğu kayını, yağışın yıl içinde dağılımının düzenli, oransal nemin yüksek ve sıcaklık ekstremlerinin fazla olmadığı yetişme ortamlarının ağacıdır (Atay, 1982b). Meşeler taksonomik yönden karmaşık bir yapı oluşturmalarının yanında çok fazla melez oluşturma özelliğine sahip olan türlerdendir. Türkiye orman alanları içinde iğne yapraklı türlerden sonra en fazla alanı % 22.78 ile yayvan yapraklı ağaç türlerinden olan meşeler kaplamaktadır. Meşelere Türkiye'nin hemen bütün bölgelerinde rastlamak mümkündür. Doğal 18 adet farklı meşe türüyle dünyada önemli meşe ülkelerinden biri olarak bilinen ülkemizde bazen saf bazen de karışık ormanlar kurmaktadır ve hemen bütün toprak şartlarında yetişmeye uygun bir tür durumundadır (Efe ve ark., 2011). Kestaneler, *Fagaceae* familyasının *Castanea* cinsine mensupturlar. Kestanelerin doğal yayılma alanları özellikle Kuzey Yarım Kürenin ılıman bölgeleri olan Çin, Kore, Japonya, Türkiye, Avrupa ve Kuzey Amerika ile birlikte Boliviya'dır. Kestane değerli bir ağaçtır. Kabukları, odunu, yaprağı ve kömürü değişik amaçlarla endüstride kullanılmaktadır. Ekonomik açıdan meyveleri büyük öneme sahiptir. (Delen, 1992).

Hsp70 gen ailesinin moleküler işlevlerine ait bazı çalışmalar yapılmıştır. Fakat, *Fagaceae* familyası (Amerikan kayını, Amerikan kestanesi, Çin kestanesi, Avrupa kestanesi, Japon kestanesi, Meşe, Kırmızı meşe ve Ak meşe) HSP70 gen ailesinin genom analizi ve gen karakterizasyonuna ait çok sınırlı çalışma mevcuttur. Bu çalışmada; Tanımlanan HSP70 gen ailesi dizilerinin genomdaki dağılımları, korunmuş motiflerinin tanımlanması ve tahmini üç boyutlu protein yapılarının belirlenmesi hedeflenmiştir.



## 2. Materyal ve yöntem

### 2.1. Hsp70 genlerinin analizi ve tanımlanması

*Fagaceae* familyasına ait Kayın, Meşe ve Kestane türlerinde potansiyel *Hsp70* genlerini tanımlamak için “Heat Shock Protein Database Information Resource” (<http://pdslab.biochem.iisc.ernet.in/Hspir/index.php>) veri tabanı kullanılmıştır. Farklı bitkilerde tanımlanması yapılmış olan tüm *Hsp70* genlerinin (20 farklı bitki türü/290 aminoasit sekansı) taraması yapılarak ilgili sekanslar veri tabanından indirilmiştir. Kayın, Meşe ve Kestanede belirlenen *Hsp70* proteinleri *Fagaceae* Blast veri tabanı (<http://www.fagaceae.org/node/318861>) kullanılarak varsayılan veya tanımlanmamış proteinler ile eşleştirilmiştir. Eşleştirilen sekanslar ([www.fr33.net](http://www.fr33.net)) translator kullanılarak intron bölgeleri çıkartılıp, ekzon bölgeleri elde edilmiştir. EXPASY veri tabanı kullanılarak ([web.expasy.org/decrease\\_redundancy](http://web.expasy.org/decrease_redundancy)) tekrar eden sekanslar elimine edilmiştir. Kalan tüm sekanslar için SMART (<http://smart.emblheidelberg.de>) (Letunic ve Bork, 2011) ve Pfam (<http://pfam.sanger.ac.uk>) veri tabanları kullanılarak *Hsp70* gen ailesi ile eşleşme olup olmadığı doğrulanmıştır.

### 2.2. Dizi hizalaması, filogenetik analizler ve korunmuş motiflerin belirlenmesi

Aminoasit dizileri, MEGA 7 (Tamura vd., 2011) programına yüklenmiştir. Çoklu dizi hizalamaları, ClustalW programı kullanılarak yapılmıştır. Hizalanan dizi dosyası, komşu birleştirme (Neighbor Joining) yöntemi ile 1000 tekrarlı önyükleme sekmesi (Bootstrap: 1000) seçilerek filogenetik ağaç oluşturulmasında kullanılmıştır (Saitou ve Nei, 1987). Protein dizi motifleri ise DNA motif tarama aracı (MEME) (<http://meme.nbcr.net/meme3/meme.html>) (Bailey ve Elkan, 1994) veri tabanına yüklenerek belirlenmiştir. Analizler için maksimum motif sayısı 20, optimum motif genişlikleri  $\geq 2$  ve  $\leq 300$ 'dür.

### 2.3. Hsp70 proteinlerinin homoloji modellemesi

*Fagaceae* familyasında tanımlanan tüm *Hsp70* genleri, benzer dizi ve bilinen üç boyutlu yapıya sahip en iyi örneği belirlemek için BLASTP yapılarak Protein Data Bank'da (PDB) (Berman vd., 2000) taranmıştır. Elde edilen bilgi için SWISS-MODEL Homology <https://swissmodel.expasy.org> programı kullanılarak homoloji modellemesi ile protein yapısı tahmin edilmiştir (Benkert, 2011).

## 3. Results

### 3.1. FagHsp70, QuerHsp70 ve CasHsp70 Hsp70 proteinini kodlayan sekansların karakterizasyonu

Aday *Hsp70* genlerini tanımlamak için; veri tabanında mevcut olan tüm bitkilerde daha önceden tanımlanmış olan sekans bilgileri BLAST yapılmıştır. Hidden Markov Model (HMM) yöntemi uygulanmış ve bir karşılaştırma yapılmıştır. Bulunan sekansların *Hsp70* ile ilişkisini tekrar değerlendirmek üzere sekans bilgileri Pfam ve SMART veri tabanlarına girilmiştir. Toplamda 136 adet gen dizisi belirlenmiştir. Bu genlerin genom üzerinde korunduğu düşünerek, birbirlerini içeren tekrar bölgeleri expasy veri tabanı sonuçlarına göre elimine edilmiştir. Sonuçta *Fagus* spp. genomuna ait 13 adet *Hsp70* gen dizisi tanımlanmıştır. *FagHsp70-01*'den *FagHsp70-13*'a kadar bir isimlendirme yapılmıştır. *Quercus* spp. genomuna ait 17 adet *Hsp70* gen dizisi tanımlanmıştır. *QuerHsp70-01*'den *QuerHsp70-17*'e kadar bir isimlendirme yapılmıştır. *Castanea* genomuna ait 15 adet *Hsp70* gen dizisi tanımlanmıştır. *CasHsp70-01* den *CasHsp70-15*'e kadar bir isimlendirme yapılmıştır.

Bireysel olarak *Hsp70* genleri mısır da (Rochester vd., 1986), arpada (Chen vd., 1994) ve nohutta (Dhankher vd., 1997) tanımlanmış olmasına rağmen, genomik seviyede ilk *Arabidopsis*'de 18 *Hsp70* gen ailesi (Lin vd., 2001; Sung vd., 2001) tanımlanmıştır. Son yıllarda yapılan çalışmalarda pirinçte 32 *Hsp70* genin karakterizasyonu yapılmıştır (Jung vd., 2013). Kavakta 34 *Hsp70* geni bulunmuştur (Yer vd. 2016). Yaptığımız çalışmada benzer şekilde *Hsp70* gen ailesine ait *Fagaceae* familyasında (Kayın 13, Meşe 17 ve Kestane 15) toplam 45 adet gen tanımlanmıştır.

### 3.2. FagHsp70, QuerHsp70 ve CasHsp70 geninin filogenetik analizleri ve korunmuş motiflerin belirlenmesi

Korunmuş *Hsp70* proteinlerinin yapısının evrimsel olarak dağılımını anlamak için detaylı filogenetik sınıflandırma yapılmıştır. 13 *FagHsp70*, 17 *QuerHsp70* ve 15 *CasHsp70* proteinleri için filogenetik ağaç oluşturulurken “komşu birleştirme (Neighbour-Joining, NJ) yöntemi” kullanılmıştır. 1000 tekrarlı bootstrap analizinden dolayı, dallar arasında yüksek bootstrap değerleri elde edilmiştir. Böylece, yüksek ‘bootstrap’ değeri ile gruplandırmalar için homojen ve güvenilir bir sonuç elde edilmiştir. Kayın, Meşe ve Kestane için yapılan filogenetik analiz sonucunda 3 ana grup oluşmuştur (Grup-1, Grup-2, Grup-3). Sırasıyla her grupta kayın için 6, 4 ve 3 - meşe için 11, 5 ve 1 - kestane için 10, 3 ve 2 protein bulunmaktadır (Şekil 1). Tüm gruplar kendi içerisinde farklı alt grup oluşturmuştur. Grupların kendi arasında oluşturduğu alt grupları da farklı oranlarda kümeleme göstermiştir.

Filogenetik ağaç yapısı *Arabidopsis* ve pirinç için de benzer bir yapı oluşturmuştur. *Arabidopsis*'de Hsp70 proteinleri 2 ana grup altında 7 alt grup oluşturmuştur (Lin vd. 2001). Pirinçte ise 4 ana grup oluşturmuştur (A-B-C-D) bu gruplarda farklı alt gruplara ayrılmıştır (Sarkar vd., 2013).

Filogenetik ağacın doğruluğunu kontrol edebilmek için korunmuş motiflerin analizi yapılmıştır. MEME veri tabanına Hsp70 proteinlerinin tüm aminoasit sekansları yüklenmiştir. Hsp70 için 10 farklı korunmuş motif tanımlanmıştır. Filogenetik ağaçta yer alan çoğu Hsp70 proteinin benzer motif yapısına sahip olduğu belirlenmiştir. Bazı motiflerin ise farklı gruplarda olduğu belirlenmiştir. Tanımlanan motifler ile *Fagaceae* familyasına özgü bir yapı oluşturulmuştur. Hsp70 proteinleri kendi içerisinde korunmuş bölgeler içermektedir (Şekil 2; Tablo 1).

Pirinç de Sarkar vd. (2013) C uç bölgesinde ve ATP bağlanmalarında yüksek motif benzerliğinin olduğunu bulmuşlardır. Ayrıca, Hsp70 proteinleri için filogenetik ağaçta görülen yakınlık incelendiğinde, sekansların motif yapısı olarak benzerlik gösterdiğini belirlemişlerdir (Sung vd., 2001). *Arabidopsis* de N uç bölgesinin başlangıcı ATP bağlanmalarında yüksek oranda korunmuştur. *Arabidopsis*'de ATP bağlanmasında işlev alan motif yürütülen bu çalışmada motif 2 olarak tanımlanmıştır. Dolayısıyla bu çalışmadan elde edilen sonuçlar ile literatürde bulunan sonuçlar benzerlik göstermektedir. *Hsp70* gen ailesi üyeleri evrimsel açıdan korunmuş motif bölgeleri içermesinden dolayı, farklı bitkilerde ve orman ağaçlarında filogenetik açıdan benzer dağılımlar gösterdiği düşünülmektedir.

### 3.3. *FagHsp70*, *QuerHsp70* ve *CasHsp70* Proteinlerinin homoloji modellemesi

Homoloji modellemesi için *Fagaceae* veri tabanı içerisinde BLAST taraması yapılmıştır. Yüksek doğruluk belirleyebilmek için SWISS-MODEL Homology programına aminoasit sekansları yüklenmiştir. Belirlenen proteinin modellenme yüzdesi >90% güven düzeyinde 65 den 80 e kadar değişiklik gösteren benzerlik oranı tespit edilmiştir. Toplamda 4 *FagHsp70*, 4 *QuerHsp70* ve 5 *CasHsp70* proteinleri yüksek homoloji göstermektedir (Şekil 4). Hsp70 proteinlerinin moleküler fonksiyonlarının anlaşılabilmesi için protein yapısının bu şekilde tahmin edilmesi yüksek doğruluk belirlemektedir (Şekil 3; Şekil 4; Şekil 5).

## 4. Sonuçlar ve tartışma

Isı şoku proteinleri (Hsps: Heat shock proteins), canlı organizmalarda bulunan bir grup protein ailesidir ve aynı zamanda literatürde stres proteinleri olarak da isimlendirilmektedir. Isı şoku protein geni 70 (Hsp70) ailesi üyeleri moleküler şaperonlar olarak bilinmektedirler. Stres anında (örneğin tuzluluk, kuraklık ve ekstrem sıcaklık değişimleri) proteinlerin doğru katlanmasında ve dokuların korunmasında önemli bir rol üstlenmektedirler. Birçok çalışma, bireysel aile üyelerinin moleküler fonksiyonlarını belirlemek için yapılmış olsa da, *Fagaceae* familyası Hsp70'lerin yapısal genomlarının belirlenmesi ve karakterizasyonu üzerine sınırlı bir çalışma bulunmaktadır.

Bu çalışmada; *Hsp70* gen ailesine ait kayın, meşe ve kestanede sırasıyla 13, 17 ve 15 olmak üzere *Fagaceae* ailesine ait toplam 45 adet gen tanımlanmıştır. Filogenetik analiz sonucuna göre; *Hsp70* genleri 3 farklı grup oluşturmuştur. Yapılan motif analizine göre Hsp70 proteinlerinin genom içerisinde (kayın, meşe ve kestanede) nispeten korunduğu görülmüştür. Proteinlerin üç boyutlu modellemesi yapıldığında toplam *Fagaceae* familyasına ait 13 Hsp70 geni >%90 güven düzeyinde test edilmiştir. Bu on üç protein "(*FagHsp70*-03(%68) / *FagHsp70*-08(%65) / *FagHsp70*-09(%71) / *FagHsp70*-13(%80) / *QuerHsp70*-03(%65) / *QuerHsp70*-04(%68) / *QuerHsp70*-09(%71) / *QuerHsp70*-14(%77) / *CasHsp70*-03(%65) / *CasHsp70*-04(%67) / *CasHsp70*-11(%65) / *CasHsp70*-14(%65) / *CasHsp70*-15(%61)" data bankta bulunan proteinlerle yaklaşık %65-80 arasında üç boyutlu homoloji modellemesi göstermiştir. Bu sonuçlar *Fagaceae* familyasında *Hsp70* gen ailesinin karakterizasyonu ve fonksiyonel işlevleri hakkında bilgi sağlamaktadır. Ayrıca, *Fagaceae* familyası için kuraklık stresi toleransı mekanizmasının belirlenmesinde temel bir ipucu göstermektedir.

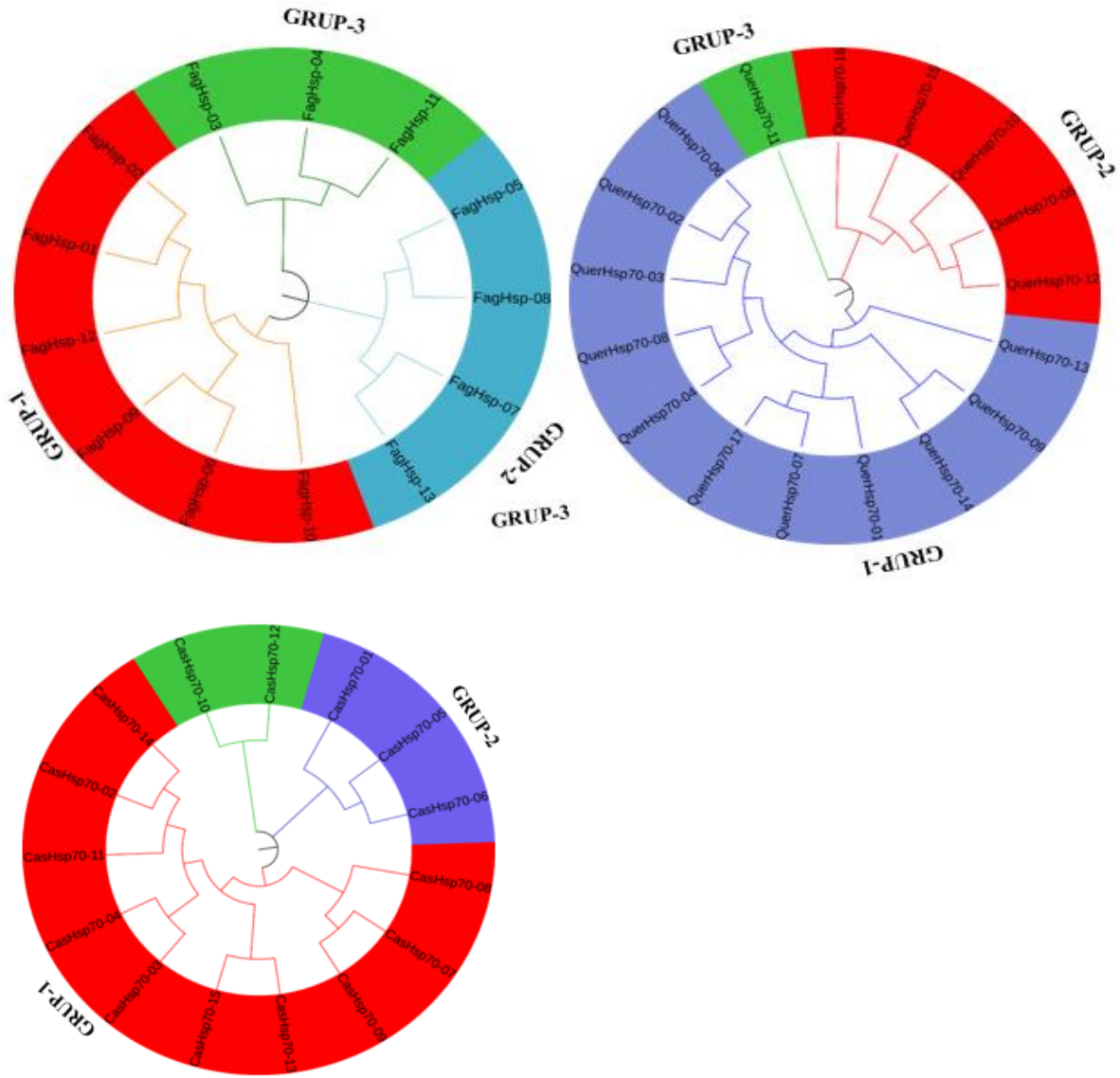

Şekil 1. FagHsp70, QuerHsp70 ve CasHsp70 proteinlerinin filogenetik sınıflandırması

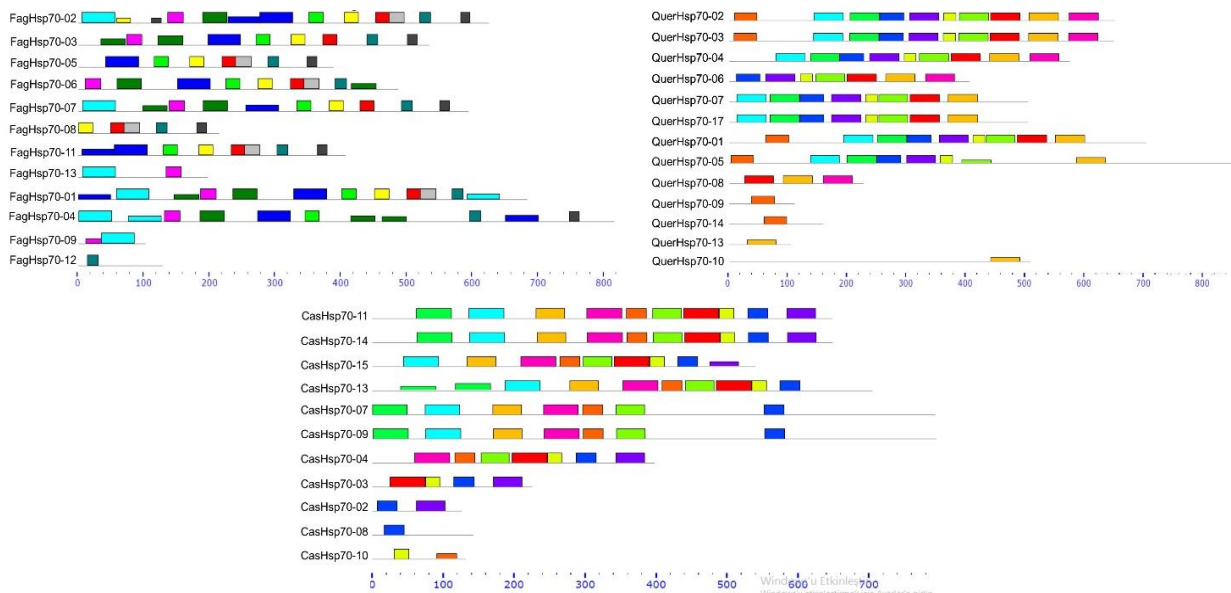

Şekil 2. FagHsp70, QuerHsp70 ve CasHsp70 genlerinin motif dağılımlarının gösterimi

Tablo 1. FagHsp70, QuerHsp70 ve CasHsp70 aminoasitlerinin motif kompozisyonu

Motif No.	Motif Sayısı	E-değeri	FagHsp70 Aminoasit Sekanslarının Motif Kompozisyonları	Uzunluk (aa)
Motif 1	4	1.3e-083	IDLGTTYSCVGVWQHDRV EIIANDQGNRTTPSWVAFDTSERLIGDAAKNQ	50
Motif 2	7	1.5e-076	IDSLEYEGIHFYSTITRARFEELNMDLFRKCMPEPVEKCLRDAMDKSSVHD	50
Motif 3	8	9.3e-065	PPAPRGVPQIEVCFDIDANGI	21
Motif 4	7	8.6e-062	AVVTVPAYFNDSQRQATKDAGVI	23
Motif 5	8	7.8e-057	PRNTTIPTKKSQVFSTYSDNQ	21
Motif 6	8	4.5e-043	CKSINPDEAVAYGAAVQCAIL	21
Motif 7	10	2.3e-030	IDAKNALENYVYNMRN	16
Motif 8	7	1.5e-022	LESICNPIIAKMYQ	14
Motif 9	5	3.1e-031	NVLIFDLGGGTFDVSILTIEEGIFEVKAHSGDTHLGG	37
Motif 10	6	1.8e-022	LNVSAEDKTTGQKNKITITNDKG	23
Motif No.	Motif Sayısı	E-değeri	QuerHsp70 Aminoasit Sekanslarının Motif Kompozisyonları	Uzunluk (aa)
Motif 1	8	7.9e-168	QTQVLIQVYQGERTMTRDNNLLGKFELSGIPPAPRGMPQIEVCFDIDANG	50
Motif 2	7	5.2e-133	VKNAVVTVPAYFNDAQRQATKDAGRIAGLHVMRIINEPTAAALAYGMDKK	50
Motif 3	7	1.9e-125	GEGNEDVQDLLLLDVTPLSLGLETLGGVMTRLIPRNTTIPTKKSQVFSTY	50
Motif 4	8	9.2e-111	TRARFEELNMDLFRRCMEPCENCLRDAKMTKSTIHEVVLVGGSTRIPKVQ	50
Motif 5	8	4.6e-105	QITITNDKGRLSQDEIEKMQEAEKYASEDQEHKEKIDAKNSLETYIYNM	50
Motif 6	7	3.0e-094	FDLGGGTFDVSILTISNGVFEVKATNGDTHLGGEDFDNRLMDYFVQEFKR	50
Motif 7	8	6.1e-068	KNKIDISKNPRAQLRLTACERAKRTLSSTHQTINIPLY	41
Motif 8	5	4.9e-066	KKKIEDAIDQAIQWLDGNQLAEAEDEFEDKMKELESICNPIIAKMYQGSGG	50
Motif 9	6	1.7e-060	VIGIDLGTTYSCVGVWQHGHEVEIANDQGNRTTPSWVAF	39
Motif 10	8	1.1e-043	GKEPCKSINPDEAVAYGAAVQ	21
Motif No.	Motif Sayısı	E-değeri	CasHsp70 Aminoasit Sekanslarının Motif Kompozisyonları	Uzunluk (aa)
Motif 1	6	2.9e-106	QTTVLIQVYEGERTLTRDCNLLGKFELSGIPPAPRGVPQIEVCFDIDANG	50
Motif 2	6	2.2e-097	YLNATVVNCCITVPAYFNDSQRQATKDAGTIAGLHVLRINEPTAAALAY	50
Motif 3	7	3.7e-077	LLWLDVTPLSLGLETLGGVMTVLIIPRNTTIPTKKSQVFSTY	41



**Kaynaklar**

- Atalay, İ., 1992. Kayın (*Fagus orientalis* Lipsky.) Ormanlarının Ekolojisi ve Tohum Transferi Yönünden Bölgelere Ayrılması, Orman Bakanlığı, Orman Ağaçları ve Tohumları İslah Araştırma Müdürlüğü, Yayın No:5, Ankara.
- Atay, İ., 1982a. Doğal Gençleştirme Yöntemleri II (Önemli Ağaç Türlerimizin Silvikültürel Özellikleri ve Bu Özelliklere Göre Gençleştirme Yöntemlerinin Uygulanması). İ.Ü. Orman Fakültesi Yayını, No. 3012/320.
- Atay, İ., 1982b. Doğal Gençleştirme Yöntemleri I (Doğal Gençleştiriminin Başarısını Etkileyen Önemli Hususlar). İ.Ü. Orman Fakültesi Yayını, No. 2876/306.
- Bailey, T.L., Elkan, C. 1994. 'Fitting a Mixture Model by Expectation Maximization to Discover Motifs in Biopolymers', Proceedings of the 'Second International Conference on Intelligent Systems for Molecular Biology', p.28-36.
- Berman, Westbrook et al. 2000. Nucleic Acids Res. 28, 235-242; <http://www.pdb.org/>. Benkert, P., Biasini, M., Schwede, T. 2011. Toward the estimation of the absolute quality of individual protein structure models. Bioinformatics, 27, 343-350.
- Chen, F., Hayes, P.M., Mulrooney, D.M. and Pan, A. 1994. Nucleotide sequence of a cDNA encoding a heat-shock protein (HSP70) from barley (*Hordeum vulgare* L). Plant Physiol 106 (2): 815.
- Dhankher, O.P., Drew, J.E., Gatehouse, J.A. 1997. Characterization of a pea Hsp70 gene which is both developmentally and stress-regulated. Plant Mol Biol 34(2):345-52.
- Delen, N. 1992. Ege Bölgesi' nde yeni bir hastalık: Kestane Kanseri. Ege Tarımsal Araştırma Enstitüsü Müdürlüğü, TYUAP Ege-Marmara Dilimi, Bahçe Bitkileri Grubu Abav Toplantısı, (3-6 Kasım 1992), Menemen-İzmir.
- Frydman, J. 2001. Folding of newly translated proteins in vivo: the role of molecular chaperones. Annual Review of Biochemistry 70, 603-647.
- Efe, R., Soykan, A., Curebal, I., Sonmez, S. 2011. Dede Korkut Monument Oak (*Quercus infectoria* Olivier) (Kadıköy-Edremit-Balıkesir, Turkey) The 2nd International Geography Symposium GEOMED2010, Procedia Social and Behavioral Sciences, (19) 627-636.
- Hartl, F.U. 1996. Molecular chaperones in cellular protein folding. Nature 381, 571-580.
- Jung, K.H., Gho, H.J., Nguyen, M.X., Kim, S.R., An, G. 2013. Genome-wide expression analysis of HSP70 family genes in rice and identification of a cytosolic HSP70 gene highly induced under heat stress. Funct Integr Genomics 13(3):391-402. doi: 10.1007/s10142-013-0331-6.
- Letunic I., Bork, P. 2011. Interactive Tree Of Life v2: online annotation and display of phylogenetic trees made easy. Nucleic Acids Res 39: W475-8. doi: 10.1093/nar/gkr201.
- Liberek, K., Lewandowska, A., Zietkiewicz, S. 2008. Chaperones in Control of Protein Disaggregation. The EMBO Journal, Sayı 27, s. 328-335.
- Lin, B.L., Wang, J.S., Liu, H.C., Chen, R.W., Meyer, Y., Barakat, A., Delseny, M. 2001. Genomic analysis of the Hsp70 superfamily in Arabidopsis thaliana. Cell Stress Chaperones 6 (3):201-208.
- Morimoto, R.I. 1998. Regulation of the heat shock transcriptional response: Cross talk between a family of heat shock factors, molecular chaperones, and negative regulators. Genes and Development 12, 3788-3796.
- Pelham, H.R.B. 1986. Speculations on the functions of major heat shock and glucose regulated proteins. Cell 46, 959-961.
- Ritossa, F. 1996. "Discovery of the heat shock response". Cell Stress Chaperones 1 (2): 97-8. doi:10.1379/1466-1268(1996)001<0097:DOTHSR>2.3.CO;2. PMC 248460. PMID 9222594.
- Rochester, D.E., Winer, J.A., Shah, D.M. 1986. The structure and expression of maize genes encoding the major heat-shock protein, Hsp70. EMBO J. 5:451-458.
- Sarkar, N.K., Kundnani, P., Grover, A. 2013. Functional analysis of Hsp70 superfamily proteins of rice (*Oryza sativa*). Cell Stress Chaperones, 18(4):427-437.
- Saitou, N., Nei, M. 1987. The neighbor-joining method: a new method for reconstructing phylogenetic trees. Mol. Biol. Evol. 4-406-425.
- Sorensen, J.G., Loeschcke, V. 2004. Effects of relative emergence time on heat stress resistance traits, longevity and Hsp70 expression level in Drosophila melanogaster, Journal of Thermal Biology 29(4-5): 195-203.
- Sung, D.Y., Vierling, E., Guy, C.L. 2001. Comprehensive expression profile analysis of the Arabidopsis Hsp70 gene family. Plant Physiol, 126(2):789-800.
- Tamura, K., Peterson, D., Peterson, N., Stecher, G., Nei, M., et al. 2011. MEGA5: Molecular evolutionary genetics analysis using maximum likelihood, evolutionary distance, and maximum parsimony methods. Mol Biol Evol 28:2731-2739. doi:10.1093/molbev/msr121.
- Thomas, N. A., Deng, W., Puente, J. L., Frey, E. A., Yip, C. K., Strynadka, N. C. & Finlay, B. B. 2005. CesT is a multi-effector chaperone and recruitment factor required for the efficient type III secretion of both LEE- and non-LEE-encoded effectors of enteropathogenic Escherichia coli. Mol Microbiol 57, 1762-1779.
- Yer, E.N., Baloglu, M. C., Ziplar, U.T., Ayan, S., Unver, T. 2016. Drought-Responsive Hsp70 Gene Analysis in Populus at Genome-Wide Level. Plant Mol Biol Repor. 34:483-500. doi:10.1007/s11105-015-0933-3.

(Received for publication 10 April 2016; The date of publication 15 August 2016)

## **Makale Yazım Kuralları / Instructions for Authors**

1. **Yayınlanmak üzere gönderilen yazı orijinal, daha önce hiçbir yerde yayınlanmamış olmalı veya işlem görüyor olmamalıdır.** Yazılar internet ortamında gönderilmelidir. Yazı ile ilgili tüm sorumluluk yazar(lar)a aittir.
1. *The original and all reproductions of the manuscripts must be legible. Two copies of the manuscript should be mailed or submitted personally to the relevant field editor. In the case of quotations all responsibility will be on the author(s)*
2. Yazar(lar) yazının telif haklarını dergi sahibine devrettiklerini bildiren bir telif sözleşmesi imzalar ve bunu posta ile dergi adresine gönderir.
2. *A Copyright Agreement will be signed by the author(s) and it is sent to the journal address by postal service.*
3. Gönderilecek eserler, Biyolojik Çeşitlilik ve Koruma dallarında olmalıdır. Eserler Türkçe veya İngilizce olarak sunulabilir.
3. *The manuscript submitted and written either in English or Turkish should be on Biological Diversity and Conservation*
4. Makale A-4 boyutundaki kağıda bilgisayar 1 aralıklı olarak yazılmalıdır. Sayfa kenar boşlukları 2 cm olmalıdır. Sayfaların üst sağ köşesine sayfa numarası konmalıdır. Font büyüklüğü 10 punto olmalıdır.
4. *Manuscripts should be printed on A4 papers with a minimum of 1 line spacing. Margins on the page should be 2cm. Page numbers must be placed in the upper right corner. Font size should be 10 pt.*
5. Makalenin ilk sayfasında yazının başlığı, yazarların adları ve adresleri, özet ve anahtar kelimeler bulunmalıdır. Yazı başlığı, özet ve anahtar kelimeler, hem Türkçe hem de İngilizce olarak yazılmalıdır. Yazışmaların yapılacağı yazar dipnot ile belirtilmeli ve kendisinin açık posta adresi ve elektronik posta adresi verilmelidir.
5. *First page of the manuscript should include title, authors' names and institutions, an abstract, and keywords. Title, abstract, and keywords must be provided both in English and Turkish. Corresponding author should be indicated by a footnote and besides his/her full mailing address, and an e-mail address should also be provided.*
6. **Özet** 400 kelimeyi geçmeyecek şekilde İngilizce ve Türkçe yazılmalıdır. Önce makalenin İngilizce adı, sonra İngilizce özet yazılmalı. Daha sonra makalenin Türkçe adı yazılmalı ve Türkçe özet yazılmalı.
6. *Abstract for a maximum of 400 words should be placed after the address of the author on one blank line. English name of the article first and then must be written in English abstracts. Later, the Turkish name of the article should be written, after Turkish abstract should be written.*
7. **Anahtar kelimeler** özeten sonra (5 kelime), yabancı dildeki özeten sonra ise o dildeki anahtar kelimeler bir satır boşluk bırakılarak yazılmalıdır.
7. *The English title, abstract and key words should follow the Turkish key words with the same style. Key words (Anahtar Kelimeler) should be written with blank line and should not exceed 5 words.*
8. **Metin** giriş bölümüyle başlamalı ve uygun bölümlere ayrılmalıdır. Bölümler, ardışık olarak numaralandırılmalıdır. Bölüm başlıkları numaralarıyla birlikte sola dayalı olarak küçük harflerle (1. Giriş, 2. Materyal ve yöntem, 3. Bulgular, 4. Sonuçlar ve tartışma şeklinde) ve koyu renkli yazılmalıdır. Alt bölümler, her bölüm içinde bölüm numarası da kullanılarak "1.1", "1.2"

şeklinde numaralandırılmalı ve sola dayalı olarak yazılmalıdır. Son bölümde **Teşekkür** (varsa), **Kaynakça** ve **Ekler** (varsa) yer almalıdır.

8. **The text** should start with the Introduction, and be divided into appropriate sections. Sections must be numbered consecutively. Section headings must be written in lower case with their numbers (as, **1. Introduction, 2. Material and method, 3. Results, 4. Conclusions and discussion**) and must be written left justified and bold. Subsections must be numbered as "1.1", "1.2", etc., using the section number and must be written left justified and lower case. The final section must be **Acknowledgements, References and Appendices** must follow this section.

9. **Şekiller**, grafikler, fotoğraflar ve çizelgeler metin içerisinde ilgili yere yerleştirilmelidir.

9. **Figures**, tables and illustrations should be inserted to the appropriate positions where they are mentioned in the text.

10. **Tüm çizimler, grafikler, fotoğraflar**, vb. şekil olarak değerlendirilmeli ve ardışık olarak numaralanmalıdır (Şekil 1.).

10. **All drawings, graphics, photographs**, etc. should be regarded as figures. Figures should be numbered consecutively (as Figure 1.).

11. **Tablolar** ardışık olarak "Tablo 1." şeklinde numaralandırılmalıdır.

11. **Tables** should be numbered as "Table 1." consecutively

12. Metin içinde diğer eserlere yapılan **atıflar**, yazar soyadı ve yıl kullanılarak "(Yazar, 2008)" veya "Yazar (2008)" şeklinde yapılmalıdır. İki yazarlı eserlerde iki yazarın soyadı da "(Yazar ve Yazar, 2008)" veya "Yazar ve Yazar (2008)" şeklinde kullanılmalıdır. Daha çok yazarlı eserler, yalnızca ilk yazarın soyadı verilerek "Yazar vd., 2008" şeklinde ve yine benzer biçimde yıl yazılarak kullanılmalıdır. Atıfta bulunan eserler **Kaynaklar** bölümünde ilk yazarın soyadına göre alfabetik olarak sıralanmalıdır. Kaynaklar'da tüm yazarların soyadları ve diğer adlarının ilk harfleri yer almalıdır. (Yayımlanmamış çalışmalar Kaynakça'da yer alamaz.) Kaynaklar aşağıdaki örneklere uygun olarak yazılmalıdır:

Yücel, E. 1998. *Galanthus gracilis*'in yeni bir yayılış alanı ve ekolojik özellikleri. Ekoloji (Çevre Dergisi). 8/29: 3-5.

Yücel, E., Ocak, A., Özkan, K., Soydam, S. 2006. Türkiye'de süs bitkileri olarak yetiştirilen ağaçlar ve çalılar. (Ed.) Zambak, E., III. Ulusal Süs Bitkileri Kongresi, İzmir. 66-77.

Yücel, E. 2013. Türkiye'de yetişen çiçekler ve yerörtücüler. Türmatsan, Eskişehir.

12. **Citations** to other publications should be mentioned in the text by using surname of the author and year as "(Author, 2008)" or "Author (2008)". For publications with two authors, surnames of both authors should be used as "(Author and Author, 2008)". Publications having more than two authors should be cited by giving only the surname of the first author as "Author et al., 2008", and by typing the year in the aforementioned manner. Cited publications should be listed alphabetically in the References according to the surnames of the first authors. Surnames and initials of all authors must appear in the References. (Unpublished works should not be included in the References.). References should be written according to the following examples:

Çelik, S., Özkan, K., Yücel, E. 2008. Morphological variation and plant nutrients effects of two taxonomically distant *Centaurea* species. Asian Journal of Chemistry. 20/4. 3171-3181.

Yücel, E. 2000. Effects of different salt, nitrate and acid concentrations on the germination of *Pinus sylvestris* seeds, In (Ed.) Gözükırmızı, N., Proceedings of the 2nd Balkan Botanical Congress, Istanbul, Turkey. Volume II, 129-136.



Richardson, D. M. 1998. Ecology and biogeography of *Pinus*. Cambridge University Press, Cambridge, England.

13. Yazar (lar) yayınlamak istedikleri makaleyi aşağıda **EK:1** de örneği verilen tanımlayıcı bir üst yazıya ekleyerek “e-posta” ile göndermeleri gerekir.

*13. Author(s) should send their submissions together with a cover letter of manuscript via e-mail an example of which is given in the following **ADDITION: 1***

14. Yazarlar göndermiş oldukları makaleye hakemlik yapmak üzere, konunun uzmanı olan 5 hakem adı önerir (Adı, Adresi, e-posta adresi).

*14. Author(s) should send a list of 5 reviewers names for their (his/her) manuscript(s) (Name, Address, e-mail).*

15. Bir yazının yayımlanmasına, editör ve yayın kurulu, hakemlerden gelecek raporları değerlendirerek karar verir.

*15. The final decision about the manuscript will be made by the editor and editorial board considering the views of the referees .*

16. Dergiye abone olan yazarların makalelerine yayın sırasında öncelik verilir.

16. The authors subscribe to the journal that priority is given to the time of publication of their articles.

**EK: 1, Tanımlayıcı mektup örneği, Türkçe**

Sayın, Ersin Yücel

“.....” başlıklı makale orijinal olup, “*Biological Diversity and Conservation*” adlı derginizde yayımlanmasını istiyorum.

Makale daha önce hiç bir yerde yayımlanmış ve yayımlanmak üzere işlem görmemektedir.

.....

**ATTACHMENT: 1, Sample cover letter**

**Dear, Editor Ersin Yücel,**

*I would like to submit my manuscript titled as “ ..... ” to be published in “Biological Diversity and Conservation” as an original research article.*

*I confirm that the attached submission was not been published before and has not been under consideration for publication elsewhere.*

*Sincerely Yours.*

*Date  
Author Name  
Signature*



www.biodicon.com  
ISSN: 1308-8084 Online

*Biological Diversity and Conservation*  
Biyolojik Çeşitlilik ve Koruma  
ISSN: 1308-5301 Print

### Hakem Değerlendirme Formu / Reviewer Evaluation Form

Makale adı / **Article Title:**  
Makale No / **Article No:**

Lütfen sizin için uygun olan seçeneği “X” koyarak işaretleyiniz / Please indicate your answer with an “X”.

1. Makale orijinal mi? / **Is the article original?**
  - Evet / **Yes**
  - Hayır / **No**
2. Problem uygun şekilde belirlenmiş mi? / **Is the problem properly stated?**
  - Evet / **Yes**
  - Hayır / **No**
3. Problem uygun şekilde ele alınmış mı veya çözülmüş mü? / **Is the problem adequately treated or solved?**
  - Evet / **Yes**
  - Değişiklikler veya ekler gerekli / **Changes or elaborations required**
  - Hayır / **No**
4. Belgeleme / **Documentation:**
  - Tablolar / **Tables:**
    - İyi / **Good**
    - Zor anlaşılır (Tablo no: ) / **Unclear (Table no: )**
    - Gereksiz (Tablo no: ) / **Unnecessary (Table no: )**
    - Doğru değil (Tablo no: ) / **Incorrect (Table no: )**
  - Grafikler / **Graphs:**
    - İyi / **Good**
    - Zor anlaşılır (Şekil no: ) / **Unclear (Figure no: )**
    - Gereksiz (Şekil no: ) / **Unnecessary (Figure no: )**
    - Doğru değil (Şekil no: ) / **Incorrect (Figure no: )**
  - Diğer çizimler / **Other illustrations:**
    - İyi / **Good**
    - Değişiklik gerekli (Şekil no: ) / **Change needed (Figure no: )**
    - Gereksiz (Şekil no: ) / **Unnecessary (Figure no: )**
    - Düşük kalitede (Şekil no: ) / **Poor quality (Figure no: )**
  - İstatistikler / **Statistics:**
    - Uygun / **Suitable**
    - Uygun değil / **Unsuitable**
5. Sonuçların yorumu / **Interpretation of results:**
  - Doğru veya uygun / **Correct or appropriate**
  - Düzeltilmeli / **Should be amended**
  - Bulunamadı / **Not found**
6. Literatür alıntısı / **Literature cited:**
  - Uygun / **Appropriate**
  - Çok geniş / **Too broad**
  - Tam değil / **Incomplete**
7. Dil ve üslup / **Language and style:**
  - İyi yazılmış / **Well written**
  - Daha kısa ve öz olmalı / **Should be made more concise**
  - Tekrar yazılmalı veya düzenlenmeli / **Should be rewritten or edited**
8. Makale başlığı / **Article title:**
  - Uygun / **Appropriate**

- Çok uzun / **Too long**  
 Çok genel / **Too general**
9. Özet / **Abstract**:  
 Uygun / **Appropriate**  
 Çok uzun / **Too long**  
 Çok genel / **Too general**  
 Makalenin içeriğini yansıtmıyor / **Does not reflect the paper's content**
10. Anahtar kelimeler / **Key words**:  
 Uygun / **Appropriate**  
 Uygun değil / **Inappropriate**
11. Makale hakkında genel fikir / **General opinion about the paper**:  
 Yeni bulgular sağlıyor / **Provides new findings**  
 Yeni bulgular sağlıyor ama az etkili / **Provides new findings but is of marginal interest**  
 Önceki bulguların gerekli bilgisini sağlıyor / **Provides needed confirmation of previous findings**  
 Önceden bilinen çalışmaların tekrarı / **Repeats already known work**
12. Öneriler / **Recommendations**:  
 Değiştirilmeden basılmalı / **Should be published without changes**  
 Değişikliklerden sonra basılmalı / **Should be published after changes**  
 Yeniden yazım veya düzeltme sonrasında bir karar için yeniden sunulmalı / **Should be resubmitted for a decision after rewriting or editing**  
 Basılmamalı / **Should not be published**
13. Detaylı işaretlemeler (Lütfen eğer gerekliyse sayfaları ekleyin) / **Detailed remarks (Please attach pages if necessary)**:

-----  
Belirtmek istediğiniz diğer ayrıntılar (varsa) / **Other details wanted to be indicated (if exist)**  
-----

Hakemin adı / **Name of reviewer**:

Adres / **Address**:

Tel / Fax no:

e-mail:

**(Hakem adı gizli tutulur / Reviewer name is kept secret)**

**Telif Hakkı Devir Formu/ *The Copyright Agreement Form***  
 Biyolojik Çeşitlilik ve Koruma/*Biological Diversity and Conservation*  
 ISSN 1308-5301 Print; ISSN 1308-8084 Online  
 Prof. Dr. Ersin YÜCEL, P.K. 86, PTT Merkez, 26010 Eskişehir / Türkiye

Derginin Adı / *Journal Title*: Biyolojik Çeşitlilik ve Koruma/*Biological Diversity and Conservation*  
 Makalenin Adı / *Manuscript title*: .....  
 .....  
 .....  
 Yazarların Adı / *Full Names of All Authers*: .....  
 .....  
 .....  
 Yazışmaların Yapılacağı Yazarın Adı ve Adresi / *Name, Adres Of Corresponding Author*: .....  
 .....  
 .....  
 TC Kimlik No. / *ID Number*: ..... e-posta: .....

**Yazar(lar) / The Author(s) warrant(s) that:**

Sunulan makalenin orijinal olduğunu; makalenin başka bir yerde basılmadığını veya basılmak için sunulmadığını; diğer şahıslara ait telif haklarını ihlal etmediğini taahhüt eder. /

*The manuscript submitted is his own orijinale work; the manuscript has not been published and is not being submitted or considered for publication elsewhere; the manuscript do not infringre upon any existing copyright.*

“Telif Hakkı Devir Formu” tüm yazarlarca imzalanmalıdır. / *This copyright form must be signed by all authors.*

TC Kimlik No. / *ID Number*: .....  
 Adı Soyadı / *Full name*: .....  
 Tarih / *Date*: ..... İmza / *Signature*: .....

TC Kimlik No. / *ID Number*: .....  
 Adı Soyadı / *Full name*: .....  
 Tarih / *Date*: ..... İmza / *Signature*: .....

TC Kimlik No. / *ID Number*: .....  
 Adı Soyadı / *Full name*: .....  
 Tarih / *Date*: ..... İmza / *Signature*: .....

TC Kimlik No. / *ID Number*: .....  
 Adı Soyadı / *Full name*: .....  
 Tarih / *Date*: ..... İmza / *Signature*: .....

TC Kimlik No. / *ID Number*: .....  
 Adı Soyadı / *Full name*: .....  
 Tarih / *Date*: ..... İmza / *Signature*: .....

TC Kimlik No. / *ID Number*: .....  
 Adı Soyadı / *Full name*: .....  
 Tarih / *Date*: ..... İmza / *Signature*: .....

TC Kimlik No. / *ID Number*: .....  
 Adı Soyadı / *Full name*: .....  
 Tarih / *Date*: ..... İmza / *Signature*: .....



www.biodicon.com

ISSN: 1308-8084 Online

*Biological Diversity and Conservation*

Biyolojik Çeşitlilik ve Koruma

ISSN: 1308-5301 Print

**ABONE FORMU / SUBSCRIPTION FORM**

Adı / Name :  
 Soyadı / Surname :  
 Adres / Address :  
 Semt – İlçe / City- State :  
 Posta kodu / Postal Code :  
 İl / Country :  
 Telefon / Telephone :  
 Faks / Fax :  
 e-posta / e-mail :

\* Yurtiçi Abone Ücreti, **Yıllık 3 Sayı 150TL** / Annual Subscription Rate for Outside Turkey is **70 USD or 60 EUR for 3 issues.**

\*Abone olmayanlar için her bir sayı 100 TL 'dir (Türkiye içi) / Each volume is **50 USD or 40 EUR** for non-subscribers (Outside of Turkey).

Sadece belirttiğim sayıyı olmak istiyorum / I would like to have an issue;

Vol. 1/1.....( ), Vol. 1/2 ..... ( )

Vol. 2/1 .....( ), Vol. 2/2 ..... ( ), Vol. 2/3..... ( )

Vol 3/1. ....( ), Vol. 3/2..... ( ), Vol .3/3.....( )

Vol 4/1. ....( ), Vol. 4/2..... ( ), Vol .4/3.....( )

Vol 5/1. ....( ), Vol. 5/2..... ( ), Vol .5/3..... ( )

Vol 6/1. ....( ), Vol. 6/2..... ( ), Vol .6/3..... ( )

Vol 7/1. ....( ), Vol. 7/2..... ( ), Vol .7/3..... ( )

Abone olmak istiyorum / I would like to have an annual subscription;

..... ( ) 2015.....( ) 2016

Dergi isteğiniz ile ilgili ücreti “

**AKBANK, Ersin Yücel, IBAN: TR24 0004 6011 0088 8000 0256 06**” numaralı hesaba yatırdıktan sonra bu formu “**biodicon@gmail.com**” adresine ulaştırınız. Dergi adresinize posta ile adresinize gönderilecektir.

The payment of the article offering, please transfer total amount to the following bank account: “**AKBANK, Ersin Yücel, IBAN: TR24 0004 6011 0088 8000 0256 06**”. After that, this form is going to be sent the following address “**biodicon@gmail.com**”. The journal with cash on delivery will be sent your address.

Tarih / Date: ...../...../2016

İmza / Signature:

(Abone formunu Word belgesi olarak gönderiniz/Please send subscription form as a Word document)

*Biological Diversity and Conservation*

Cilt/Volume 9 Sayı 2 (Özel Sayı 1)/Number 2 (Special Issue 1) Ağustos/August 2016

**Special Issue Volume 9/2 (SI) August 2016**

**Contents / İçindekiler**

01. Variations within and among populations depending on some leaf characteristics of oriental beech (*Fagus orientalis* Lipsky)
10. Comparison of differently originated oriental beech (*Fagus orientalis* Lipsky) seedling growth in field
19. The beech (*Fagus orientalis* Lipsky) diameter frequency fit with probability distribution in Iran's north forests
25. Growth and yield for scots pine and oriental beech mixed stands in different mixture ratios
36. Bonding strength of polyvinyl acetate (PVAc) and casein adhesives in small diameter beech wood
41. Wood production potential of beech (*Fagus sylvatica* L.) from natural forests in West Central Greece
47. Variability and breeding of beech (*Fagus moesiaca/Domin, Maly/Czeczott.*) in Serbia
52. Definition of *Fagus orientalis* Lipsky. dominated biotopes in Güzelcehisar, Mugada and Kızılkum region of Bartın province
58. Definition of *Fagus orientalis* Lipsky. dominated biotopes in Güzelcehisar, Mugada and Kızılkum region of Bartın province
64. The importance of beech seed sources in Serbia for enhancement of seed and seedling production
- 68 The survey of regeneration diversity in managed and unmanaged beech stands of north forests of Iran
75. The effect of magnetic field application on chemical composition in *Fagus orientalis* Lipsky. seed
84. Identification and bioinformatics analyzes of heat shock protein 70 genes (Hsp 70) in *Fagaceae* family

Dergiyi tarayan veri tabanları / *Abstracted-Indexed in:* AGRICOLA; Bibliotheken; Buscador de Archives; Dayang Journal System; DOAJ-Directory of Open Access Journals; EBSCO Publishings databases; ECSI; Genamics JournalSeek Database; HealthHaven; HKU Scholars Hub.; ICAAP-database; Index Copernicus; InfoBaseIndex; I2OR; Journal Directory, News-of-Science; MNIS; OhioLINK Databases-OPC4-Online-Katalog der Bibliothek der Fachhochschule Anhalt; Online-Katalog der UB Clausthal; Paper Search Engine; ProQest-Central To Recherche Araund The World; Thomson Reuters; *Turkey Citation Index* Ulakbim; Zoological Record.

**Kütüphaneler / Libraries:** Aberystwyth University; All libraries; Bath University; Birmingham University; Cardiff University ;City University London; CONSER (Not UK Holdings); Edinburgh University; Essex University; Exeter University; EZB Electronic Journals Library; Feng Chia University Library; GAZİ Gazi University Library; Glasgow University; HEC-National Digital Library; Hull University; Imperial College London; Kaohsiung Medical University Library; KYBELE Anadolu University Library; Lancaster University; Libros PDF; Liverpool University; London Metropolitan University; London School of Economics and Political Science; Manchester University; National Cheng Kung University Library; National ILAN University Library; Nottingham University; Open University; Oxford University; Queen Mary,University of London;Robert Gordon University; Royal Botanic Gardens, Kew; Sheffield Hallam University; Sheffield University; Shih Hsin University Library; Smithsonian Institution Libraries; Southampton University; Stirling University; Strathclyde University; Sussex University; The National Agricultural Library (NAL); The Ohio Library and Information NetWork; Trinity College Dublin; University of Washington Libraries; Vaughan Memorial Library; York University.

*IndexCopernicus, ICV: 9.00; Thomson Reuters Impact Factor, 5.00*  
*Türkiye Atıf Dizini'ne kayıtlıdır (Turkey Citation Index)*

Dergide yayınlanan makalelere” [http:// www.biodicon.com](http://www.biodicon.com)” adresinden ulaşabilir.

*This journal is available online at [http:// www.biodicon.com](http://www.biodicon.com)*

© 2008 Tüm hakları saklıdır/All rights reserved

**ISSN 1308-5301 Print / ISSN 1308-8084 Online**

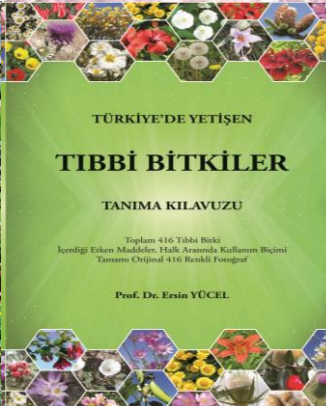
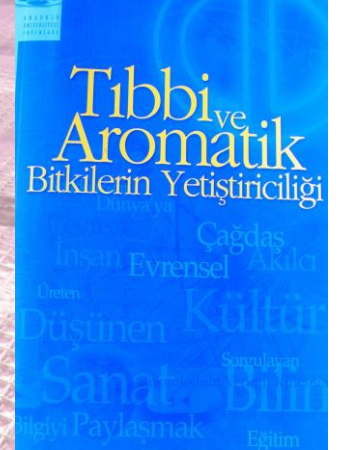
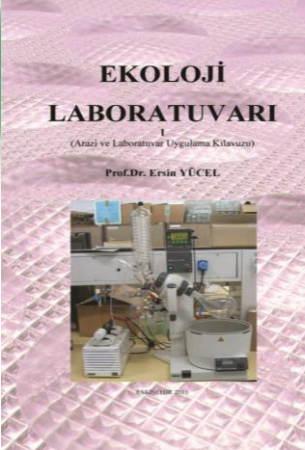
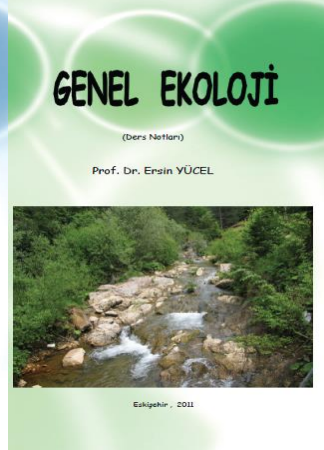
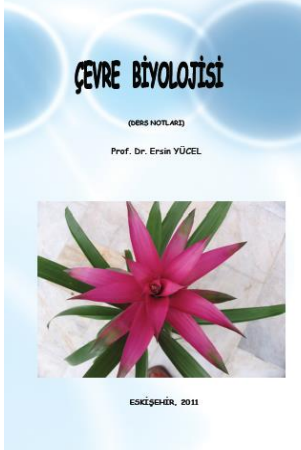
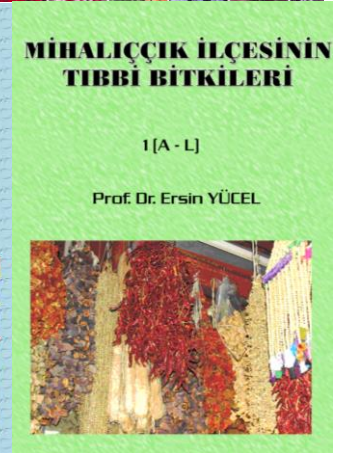
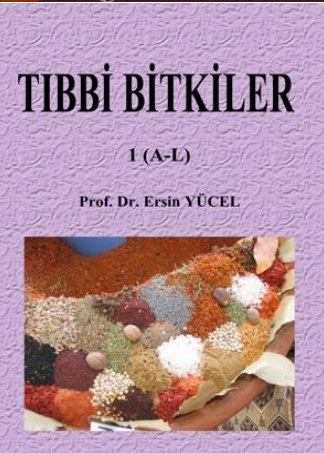
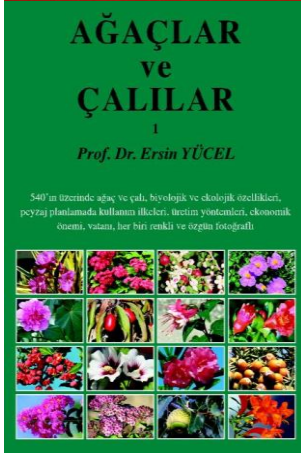
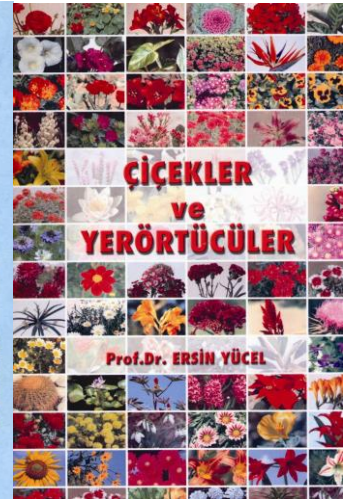
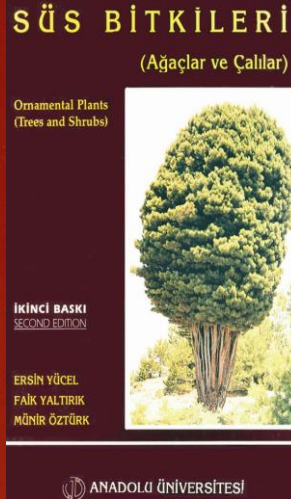

İletişim Adresi: [ebitki@gmail.com](mailto:ebitki@gmail.com)  
<http://www.bitkilerim.com>