



Journal of Naval Sciences and Engineering

Deniz Bilimleri ve Mühendisliği Dergisi

National Defence University

Milli Savunma Üniversitesi

Barbaros Naval Sciences and Engineering Institute
Barbaros Deniz Bilimleri ve Mühendisliği Enstitüsü

Volume/Cilt:18
Number/Sayı:1
April/2022

PRINTED BY/BASKI

National Defence University Turkish Naval Academy Printing House/Milli Savunma Üniversitesi Deniz Harp Okulu Matbaası

CORRESPONDENCE AND COMMUNICATION ADDRESS/YAZIŞMA VE HABERLEŞME ADRESİ

Milli Savunma Üniversitesi
Barbaros Deniz Bilimleri ve Mühendisliği Enstitüsü
Deniz Harp Okulu Yerleşkesi
Tuzla/İstanbul/Türkiye

Phone/Telefon : +90 216 395 26 30/2100-2104
Fax/Belgegeçer : +90 216 395 26 58
E-mail/E-posta : jnse@dho.msu.edu.tr
Web : <https://dergipark.org.tr/tr/pub/jnse>

**NATIONAL DEFENCE UNIVERSITY
BARBAROS NAVAL SCIENCES AND ENGINEERING INSTITUTE
JOURNAL OF NAVAL SCIENCES AND ENGINEERING**

**MİLLİ SAVUNMA ÜNİVERSİTESİ
BARBAROS DENİZ BİLİMLERİ VE MÜHENDİSLİĞİ ENSTİTÜSÜ
DENİZ BİLİMLERİ VE MÜHENDİSLİĞİ DERGİSİ**

Volume/Cilt: 18

Number/Sayı: 1

April/Nisan 2022

ISSN: 1304-2025

**Owner on Behalf of the Barbaros Naval Sciences and Engineering Institute
Barbaros Deniz Bilimleri ve Mühendisliği Enstitüsü Adına Sahibi ve Sorumlusu
Assoc.Prof.Dr. (Doç.Dr.) Ertan YAKICI**

Journal of Naval Sciences and Engineering (JNSE) is a peer reviewed, international, inter-disciplinary journal in science and technology, which is published semi-annually in April and November since 2003. It publishes full research articles, review articles, technical notes, short communications, book reviews, letters to the editor and extended versions of conference papers. Topics of interest include the technological and scientific aspects of the following areas: **Computer Science and Engineering, Electrical and Electronics Engineering, Naval/Mechanical Engineering, Naval Architecture and Marine Engineering, Industrial Engineering and Basic/Social Sciences**. The journal aims to provide a scientific contribution to the increasing needs of Turkish Armed Forces. The papers in the journal are published in English.

Following Open Access Model of Publishing, Journal of Naval Sciences and Engineering presents a variety of scientific viewpoints. The authors are responsible for the scientific, contextual and linguistic aspects of the articles published in the journal. The views expressed or implied in this publication, unless otherwise noted, should not be interpreted as official positions of the Institution.

Our journal uses “double-blind review”, which means that both the reviewer and author identities are concealed from the reviewers, and vice versa, throughout the review process. The articles submitted to JNSE to be published are free of article submission, processing and publication charges. The accepted articles are published free-of-charge as online from the journal website and printed.

DATABASES INDEXING OUR JOURNAL / TARANDIĞIMIZ VERİ TABANLARI

Open Academic Journals Index (OAJI) (13.03.2016)

Sobiad Citation Index (31.01.2018)

Scientific Indexing Services (SIS) (28.02.2018)

Arastirmax Scientific Publication Index (13.03.2018)

CiteFactor Academic Scientific Journals (14.05.2018)

Asian Digital Library (03.09.2018)

Idealonline (05.09.2018)

ULAKBİM TR Dizin (14.05.2020)

Deniz Bilimleri ve Mühendisliği Dergisi (DBMD); uluslararası düzeyde, hakemli, çok disiplinli, Nisan ve Kasım aylarında olmak üzere 2003 yılından bu yana yılda iki kez yayımlanan, bilim ve teknoloji dergisidir. Dergide; **Bilgisayar, Makine, Gemi İnşa, Elektrik/Elektronik, Endüstri Mühendisliği** ile **Temel/Sosyal Bilimler** alanlarında bilimsel nitelikli araştırma makaleleri, derlemeler, teknik notlar, kitap incelemeleri, editöre mektuplar ile konferans ve toplantıların genişletilmiş raporlarına yer verilmektedir. Dergi, Türk Silahlı Kuvvetlerinin artan ihtiyaçlarına bilimsel katkı sağlamayı amaçlamaktadır. Dergide yer alan makaleler İngilizce olarak yayımlanmaktadır.

Açık erişimli yayın politikası izleyen Deniz Bilimleri ve Mühendisliği Dergisi değişik bilimsel bakış açılarını okuyucularına sunmaktadır. Dergide yayınlanan makalelerin bilim, içerik ve dil bakımından sorumluluğu yazarlarına aittir. Doğrudan veya dolaylı olarak ifade edilen görüşler kurumun resmi görüşleri olarak görülmemelidir.

Dergimiz, makale değerlendirme sürecinde “çift-kör hakemlik” sistemini kullanmaktadır. DBMD’ye yayımlanmak üzere gönderilen makaleler; makale gönderim, işlem ve yayın ücretinden muafır. Kabul edilen makaleler, ücretsiz olarak basılı şekilde ve dergi web sayfasından çevrimiçi (on-line) olarak yayımlanmaktadır.

© 2022 Copyright by Barbaros Naval Sciences and Engineering Institute
Her hakkı saklıdır.

**NATIONAL DEFENCE UNIVERSITY
BARBAROS NAVAL SCIENCES AND ENGINEERING INSTITUTE
JOURNAL OF NAVAL SCIENCES AND ENGINEERING**

**MİLLİ SAVUNMA ÜNİVERSİTESİ
BARBAROS DENİZ BİLİMLERİ VE MÜHENDİSLİĞİ ENSTİTÜSÜ
DENİZ BİLİMLERİ VE MÜHENDİSLİĞİ DERGİSİ**

Volume/Cilt: 18

Number/Sayı: 1

April/Nisan 2022

ISSN: 1304-2025

EDITOR-IN-CHIEF / BAŞ EDITÖR

Assoc.Prof.Dr. Ertan YAKICI, National Defence U. Barbaros NSEI

EDITORS / EDITÖRLER

Asst.Prof.Dr. Özlem AKGÜN, National Defence U. Barbaros NSEI

Res.Asst. Özgenur AKTAN, National Defence U. Barbaros NSEI

EDITORIAL BOARD / YAYIN KURULU

Prof.Dr. Nurettin ACIR, National Defence U.

Prof.Dr. Serhan DURAN, Middle East Technical University

Prof.Dr. Claudio PENSA, University of Naples

Prof.Dr. Engin DELİGÖZ, Aksaray University

Prof.Dr. Rumen KISHEV, Bulgarian Academy of Sciences

Assoc.Prof.Dr. Egemen SULUKAN, National Defence U.

Assoc.Prof.Dr. Ertan YAKICI, National Defence U.

Assoc.Prof.Dr. Mustafa TÜRKMEN, Erciyes University

Assoc.Prof.Dr. Fatih ERDEN, National Defence U.

Asst.Prof.Dr. Levent ERİŞKİN, National Defence U.

ADVISORY BOARD / DANIŞMA KURULU

Prof.Dr. Ahmet Dursun ALKAN, Yıldız Technical U.

Prof.Dr. A.Arif ERGİN, Yeditepe University

Prof.Dr. Cemal ZEHİR, Yıldız Technical University

Prof.Dr. Cengiz KAHRAMAN, Istanbul Technical University

Prof.Dr. Drazan KOZAK, University of Osijek

Prof.Dr. Hakan TEMELTAŞ, Istanbul Technical University

Prof.Dr. Atilla İNCECİK, University of Strathclyde

Prof.Dr. Bettar O. el MOCTAR, University of Duisburg

Prof.Dr.Cem ERSOY, Bogazici University

Prof.Dr. Özlem ÖZKANLI, Ankara University

Prof.Dr. Sergej HLOCH, Technical University of Kosice

Prof.Dr. Yahya KARSLIĞIL, Yıldız Technical University

Prof.Dr. Süleyman ÖZKAYNAK, Piri Reis University

Prof.Dr. Serdar PİRTİNİ, Marmara University

Prof.Dr. Osman TURAN, University of Strathclyde

Prof.Dr. Giorgio TRINCAS, University of Trieste

Prof.Dr. Cem SAY, Bogazici University

REFEREES FOR THIS ISSUE / SAYI HAKEMLERİ

Ali YILMAZ

Aytuğ ONAN

Emre ÜNSAL

Gizem TEMELCAN

Hakan BİLİR

Hande GÜNAY AKDEMİR

Levent SELBUZ

Mehmet ŞAHİN

Melahat BAYAR

Mithat KAYA

Onur Özdal MENGİ

Serdar YAY

CONTENTS / İÇİNDEKİLER

Management Information Systems / Yönetim Bilişim Sistemleri

RESEARCH ARTICLE

Defence Expenditure and Financial Resources of Defence Expenditure in Turkey: A Comparative Conceptual Analysis 1-29

(Savunma Harcamaları ve Türkiye’de Savunma Harcamalarının Finansman Kaynakları: Karşılaştırmalı Kavramsal Bir Analiz)

Mehmet Bilge Kağan ÖNAÇAN, Volkan SEZGİN, Tunç Durmuş MEDENİ, İhsan Tolga MEDENİ

Computer Engineering / Bilgisayar Mühendisliği

RESEARCH ARTICLE

Supervised Machine Learning-based Classification of Network Threats/Attacks Against Computer Systems 31-59

(Bilgisayar Sistemlerine Yönelik Ağ Tabanlı Tehditlerin/Saldırıların Denetimli Yapay Öğrenme ile Sınıflandırılması)

Ercan KURU, Tolga ÖNEL, Mehmet Bilge Kağan ÖNAÇAN, Musa MİLLİ

Physics / Fizik

RESEARCH ARTICLE

Single Phase Measurement in UME Kibble Balance - 3 61-77

(UME Kibble Balans – 3 ile Tek Fazda Ölçüm)

Beste KORUTLU

NATIONAL DEFENCE UNIVERSITY
BARBAROS NAVAL SCIENCES AND ENGINEERING INSTITUTE
JOURNAL OF NAVAL SCIENCES AND ENGINEERING

VOLUME: 18

NUMBER: 1

APRIL 2022

ISSN: 1304-2025

CONTENTS / İÇİNDEKİLER

Physics / Fizik

RESEARCH ARTICLE

Radiative Corrections to Neutrino Mass in Type-3/2 Seesaw Mechanism
(Tip-3/2 Tahtarevalli Mekanizmasında Nötrino Kütlesine Gelen Işınım Sal
Düzeltilmeler)

Canan Nurhan KARAHAN

79-89

Electric-Electronic Engineering / Elektrik-Elektronik Mühendisliği

RESEARCH ARTICLE

Photovoltaic System Design and Analysis at Faculty Scale
(Fakülte Ölçeğinde Fotovoltaik Sistem Tasarımı ve Analizi)
Sevgi ALTINKÖK, Serdar KARADENİZ, Atılgan ALTINKÖK

91-120

Mathematics / Matematik

RESEARCH ARTICLE

**A Golden Section Method for the Multi-objective Fractional Solid
Transportation Problem Using the Exponential Membership Function**
(Çok Amaçlı Üç Boyutlu Kesirli Taşıma Problemi için Üstel Üyelik Fonksiyonu
Kullanarak Altın Oran Metodu)

Nurdan KARA, Hale GONCE KÖÇKEN

121-141

MİLLİ SAVUNMA ÜNİVERSİTESİ
BARBAROS DENİZ BİLİMLERİ VE MÜHENDİSLİĞİ ENSTİTÜSÜ
DENİZ BİLİMLERİ VE MÜHENDİSLİĞİ DERGİSİ

CİLT: 18

SAYI: 1

NİSAN 2022

ISSN: 1304-2025

**An ethical committee approval and/or legal/special permission has not been required within the scope of this study.*

**DEFENCE EXPENDITURE AND FINANCIAL RESOURCES OF
DEFENCE EXPENDITURE IN TURKEY: A COMPARATIVE
CONCEPTUAL ANALYSIS***

Mehmet Bilge Kağan ÖNAÇAN¹
Volkan SEZGİN²
Tunç Durmuş MEDENİ³
İhsan Tolga MEDENİ⁴

¹*Istanbul Okan University, Faculty of Applied Sciences, Department of Information Systems and Technology, Istanbul, Turkey;*
mbko@yahoo.com; ORCID: 0000-0002-7147-0945

²*Bogazici University, Department of International Trade, Istanbul, Turkey,*
volkan.sezgin@boun.edu.tr; ORCID: 0000-0001-7642-7674

³*Ankara Yıldırım Beyazıt University, Business School, Department of Management Information Systems, Ankara, Turkey,*
tuncmedeni@ybu.edu.tr; ORCID: 0000-0002-2964-3320

⁴*Ankara Yıldırım Beyazıt University, Business School, Department of Management Information Systems, Ankara, Turkey,*
tolgamedeni@ybu.edu.tr; ORCID: 0000-0002-0642-7908

Received: 05.12.2021

Accepted: 06.01.2022

*Mehmet Bilge Kağan ÖNAÇAN, Volkan SEZGİN, Tunç Durmuş MEDENİ,
İhsan Tolga MEDENİ*

ABSTRACT

Defence expenditure has an important role for a country's economy and has a greater impact on the economies of underdeveloped and developing countries. This article was prepared as a conceptual study for the purpose of answering the long-standing discussion about the share of Turkey's financial sources of defence expenditure in Turkey. In this context; basic concepts, factors affecting defence expenditures, process of determining defence budget, financial sources for defence expenditures were searched and Turkey's defence budget was compared with that of some selected other countries. The data used for comparison, were compiled from Stockholm International Peace Research Institute (SIPRI). It has been found that Turkey's defence expenditure out of its GDP plummeted after 2000, but this trend reversed and the ratio started to increase after 2015 which reached to 2.7% of in 2019. Turkey ranked the 15th with a defence budget of 20.4 billion dollars among the list of countries with the most defence budgets in 2019. Also, when Turkey's defense budget is compared with its neighbors as of 2019, it is viewed to be at an average value. Moreover, although there are areas to be improved, it is seen that there is a systematic application related to the determining, planning, implementing and checking of defence expenditure and reasonable defence expenditure is defined according to this systematic in Turkey in today's conditions. It is considered that it would be beneficial to conduct more in-depth studies on this subject in the future.

Keywords: *Defence Industry, Financial Resources of Defence Expenditure, Military Spending, SIPRI, Turkey.*

SAVUNMA HARCAMALARI VE TÜRKİYE'DE SAVUNMA HARCAMALARININ FİNANSMAN KAYNAKLARI: KARŞILAŞTIRMALI KAVRAMSAL BİR ANALİZ

ÖZ

Savunma harcamaları, bir ülkenin ekonomisinde önemli bir yere sahiptir ve özellikle az gelişmiş ve gelişmekte olan bir ülkenin ekonomisine etkisi büyüktür. Bu makale, uzun yıllardır süregelen Türkiye'nin savunma harcamalarına ayırdığı bütçe ilişkin tartışmaya cevap bulmak ve söz konusu bütçe için yararlanılan finansman kaynaklarını tespit etmek amacıyla kavramsal bir çalışma olarak hazırlanmıştır. Bu kapsamda temel kavramlar, savunma harcamalarını etkileyen faktörler, savunma bütçesinin belirlenmesi süreci ve savunma harcamaları finansman kaynakları araştırılmış, seçilmiş diğer ülkeler ile Türkiye'nin savunma bütçesi karşılaştırılmıştır. Bu karşılaştırmada Stockholm Uluslararası Barış Araştırma Enstitüsü'nün (SIPRI) verilerinden faydalanılmıştır. Türkiye'nin savunma harcamalarının 2000'li yıllarla birlikte düşüş eğiliminde olduğu, bu eğilimin özellikle 2015 sonrasında yükselişe geçtiği ve 2019'da Türkiye'nin GSYH'sının yaklaşık % 2,7'sinin savunma harcamasına ayrıldığı tespit edilmiştir. 2019 yılında Türkiye en fazla savunma bütçesi ayıran ülkeler arasında 20,4 milyar Dolar ile 15. sırada yer almıştır. Bununla birlikte, 2019 yılı itibariyle Türkiye'nin savunma bütçesinin komşularıyla karşılaştırıldığında ortalama bir değerde olduğu görülmektedir. Ayrıca, iyileştirilmesi gereken alanlar olmakla birlikte, Türkiye'de savunma harcamalarının belirlenmesi, planlanması, uygulanması ve kontrolüne ilişkin sistematik bir uygulamanın olduğu ve günümüz şartlarında makul savunma harcamalarının bu sistematığe göre tanımlandığı görülmektedir. Bu konuda gelecekte daha derinlemesine çalışmalar yapılmasının faydalı olacağı değerlendirilmektedir.

Anahtar Kelimeler: *Savunma Sanayii, Savunma Harcamalarının Finansman Kaynakları, Askeri Harcamalar, SIPRI, Türkiye.*

1. INTRODUCTION

Defence expenditure is an important component of budget expenses and it appears to maintain the sovereignty and the existence of a country. It is apparently a direct function of threats to the integrity and independence of that country. Depending on the characteristics of a nation, one can claim that the amount of the expenditures might vary significantly.

Basar and Kunu (2012, p.12) puts it forward that as one of the pure public goods, sustaining defence services is the responsibility of governments and the financing of defence expenditure is largely funded by the state budget in all countries. Even if the principles of globalization and solidarity are gaining importance nowadays, historical experiences and current events force countries to allocate sufficient budgets for their defence.

Turkey, which is one of the North Atlantic Treaty Organization (NATO) Members, is also investing hugely on the defence industries recently, as it is constantly exposed to internal and external threats due to its geopolitical and strategic importance. For this reason, an important share is allocated to the defence expenditures in Turkey from the state budget and from the incomes of the organizations that was formed with the aim of strengthening the armed forces. We see that these shares follow rather a fluctuating course due to seasonal effects in the recent years.

Researches on measuring defence spending have been object of study of many academicians and practitioners, in particular starting from 1980s. In the last four decades, plenty of valuable and crucial contributions were made by political scientists and economists who enriched datasets and renovated methodologies mainly for calculating military expenditures by different countries and investigating the relations between defence expenditures and economic growth. Although various researches have been made in relation to economic and statistical relations so far, some gaps in the literature still remain, notably concerning the conceptual framework and methods of analysis that warrant further attention.

A seminal work on military expenditure is by Brzoska (1995). In the paper, the author notes that military data is difficult to define and no credible data are available for some countries. Brzoska (1995, p.1) also states that data series on military expenditures and arms transfers must be used with caution

Defence Expenditure and Financial Resources of Defence Expenditure in Turkey: A Comparative Conceptual Analysis

as the publishing institutions have only limited resources to deal with the numerous conceptual and practical problems.

In another work of interest, Lifshitz (2003, p.68) examines the economic context of the military expenditures. He underlines that defence expenditure measures are required for analyzing the macroeconomic and industrial implications of defence, and particularly for calculating the opportunity cost and economic burden of the defence.

A study by Sandler and Hartley (1995, p.1) specifies that the defence expenditures vary among nations and provides examples to this. They note that defence sector can have significant allocative influences in nations, especially when research and development are included. According to them, in time of crisis, mobilization of forces has tremendous present and future economic ramifications on a nation.

Within the framework of economic context of expenditures, it is possible to assert that the defence spending is heavily debated in Turkey recently as it is the case for almost all countries. The studies, which concentrate on the sources of Turkey's defence expenditures and compare Turkey's defence budget with other countries' budgets, are rather limited in literature.

In this respect, this study aims to analyze financial resources of Turkish defence spending in detail, and it focuses on whether Turkey allocates a huge amount of its budget to the defence. The structure of the paper is as follows: Second section examines the basics of the defence industry in general, while financial sources of Turkish defence industry is investigated in the third part. The comparisons of Turkey's defence budget with other selected countries are unclosed in the fourth part and finally, the evaluations and conclusions are conveyed in the last section.

2. DEFENCE INDUSTRY

It would be beneficial to introduce the basics of the defence industry first, which has its own characteristics, before examining the basics and financial resources of defence expenditures in Turkey.

2.1. Definition of Defence Industry

According to the official website of the Ministry of Defence of Turkey, defence industry can be defined as the plants that produce war weapons, vehicles, equipment, ammunitions, spare parts with their important inputs and their related goods and services.

2.2. Features of Defence Industry

Ziylan et al. (1998, p. 15) and Uysalkan (2010, p. 25) indicate that the defence industry has different properties in terms of market, product, and military precision. In terms of market, it is possible to sort the properties as follows:

- The only customer in the domestic market is the government.
- The foreign markets are highly dependent on foreign political influence.
- Production is regulated by political demand and desire according to need.
- High performance and quality have primary and cost has secondary importance.
- The high technologies have to be used extensively.
- It requires large investments spread over many years and therefore very good financial management.
- The defence industry is operated under the auspices and protection of the government and organizations operating in this sector are excluded from the scope of international free trade agreements.
- It is conducted as joint military production programs with the effect of multinational defence agreements or international bilateral agreements.
- It is necessary that the production process should not be interrupted by maintaining the technological sufficiency for the development and management of critical defence systems.
- High-volume manufacturing should be able to achieve during the crisis and war periods.

Defence Expenditure and Financial Resources of Defence Expenditure in Turkey: A Comparative Conceptual Analysis

- It requires a highly qualified workforce in the fields such as Research and Development (R&D), production, quality control, project management and customer relations because of the use of advanced technologies.

In terms of defence products, it can be stated that the most vital properties of the defence industry can be sorted as being fully public property, having complex structure, needing high technology, demanding high cost, having long useful life, requiring high quality, working in severe environmental conditions, and being able to improve. From the point of view of the military precision, on the other hand; Ziylan et al. (1998, p. 41) and Uysalkan (2010, p. 18) acknowledge that defence industry has the prominent properties such as security, safety, reliability, flexibility, maintainability and interoperability.

2.3. Importance of National Defence Industry

A strong defence industry is a prerequisite for being an independent country. Failure to make good defence will negatively affect the efforts of the country to protect its national rights and interests, as Nemli (2009, p. 9) mentions that is why the services related to defence are firstly organized as a demonstration of the country's presence and power. Ziylan et al. (1998, p. 17) state that every country should have its own national defence industry in order to provide reliable, safe and confidential systems to the units related to defence in that country. In addition, the 'national' defence industry is required:

- To ensure that funds allocated for defence industry expenditures are kept within the country,
- To maintain export import balance,
- To be a locomotive for the scientific and technological developments in the country,
- To prevent the difficulty of supplying critical weapons, vehicles, equipment, ammunitions and spare parts, especially during periods of crisis and tension.

As mentioned above, the defence industry is a significant component of Turkish sovereignty and solidarity as Turkey attaches great importance to its

national defence. In terms of fighting forces, for instance, Turkish Armed Forces (TAF) ranks the 8th largest standing military force in the world while it is currently the 2th largest standing military force among NATO countries, as noted by Ziylan et al. (1998, p. 54). The realization of TAF modernization needs by the national defence industry has been ruled as a legal priority by additional article no. 12 of Law No. 1325 to be performed by ASFAT A.S. in relation to the duties and organization of the Ministry of National Defence, as noted by decree Law No. 696 on November 20, 2017, and decree law No.7 establishing Presidency of Defence Industries (PDI), whose name was Undersecretariat of National Defence before the presidential system. In this context, according to Haberturk (2015)'s news piece, while the needs of TAF were met at the level of 20% in 1980s by Turkish Defence Industry, this rate amounted to 54% in 2015 and it is almost increasing year by year.

2.4. Actors of Turkish Defence Industry

The main actors of the Turkish defence industry can be listed as follows: Presidency Defence Industry Executive Committee, Ministry of National Defence (MND), (and abrogated Turkish Armed Forces General Staff (TAFGS)), PDI, and defence industry organizations/firms. According to the Presidential Decree No. 7, Presidency Defence Industry Executive Committee is accountable for ensuring national security and preparing the armed forces for national defence. As per the Presidential Decree No. 4 dated July 15, 2018, the Chief of Staff of TAF was attached to the Ministry of Defence and has been mandated to determine the set of principles, priorities and core programs pertaining to the needs during the TAF's preparations for combat. According to the Presidential Decree No. 1 dated July 10, 2018, MND is responsible for the procurement of weapons, tools, materials and logistic necessities and for the war industry services. According to Presidential Decree No.7, which was published at the Official Gazette on July 15, 2018, PDI is responsible for applying the decisions of the Defence Industry Executive Committee, modernizing the TAF and developing of a civilian infrastructure to support the armed forces. Finally, the defence industry organizations/firms in Turkey undertake an important task to provide that the needs of the TAF are met with the latest technologies and national opportunities. In order to carry out more detailed

Defence Expenditure and Financial Resources of Defence Expenditure in Turkey: A Comparative Conceptual Analysis

and accurate analytical studies for Turkey, we consider that it would be beneficial to analyze the main financial resources comprising Turkey's defence budget within the framework of the existing literature. For this reason, Turkey's financial sources of defence expenditure will be analyzed in the next section.

3. FINANCIAL SOURCES OF DEFENCE EXPENDITURE IN TURKEY

• During the processes of implementing national defence instruments, financing is needed for organizations/businesses in order to conduct the activities, realize the projects, etc. Turk (2007, p. 26) remarks that possible financial resources of defence expenditures can be listed as follows:

- Resources allocated from the MND budget,
- Defence Industry Support Fund (DISF) resources,
- Turkish Armed Forces Foundation (TAFF) resources,
- The General Command of the Gendarmerie budget,
- Coast Guard Command budget,
- Government / Company loans,
- Foreign Military Sales (FMS),
- MND's revenues based on special laws.

Among above mentioned financial resources, Akyesilmen (2006, p.14) specifies that the most important part of the resource reserved for defence is the MND budget. As per the data from the Ministry of Finance, the share of MND, which was 6.1% of budget in 2008, dropped to 5.6% of budget in 2009. In time, the rate decreased further, and it became 4.2% in 2014. The share of MND in the total budget occurred 4.69% in 2015 and 4.8% in 2016. According to the central administration budget for 2020, the total amount allocated for MSD is 53.9 billion Turkish Lira, which was equivalent to 4.92% of the total budget. This clearly demonstrates that there has been an increasing trend since 2015.

*Mehmet Bilge Kağan ÖNAÇAN, Volkan SEZGİN, Tunç Durmuş MEDENİ,
İhsan Tolga MEDENİ*

While unveiling the details of spending on Turkish military-related activities is one of the purposes of this study, one has to bear in mind that estimating how much Turkey spends on its military requires a detailed study to trace its sources. Although some details of Turkey's military expenditure is available online—such as the budgets of the MND—access to information about other elements is limited or, in some cases, impossible, as indicated by Yenturk (2014, p. 1).

Apart from the general budget, with the aim of establishing a continuous and steady supply of the budget that is necessary for providing the modernization of the TAF and establishing the modern defence industry in Turkey, in accordance with Article 12 of Law No. 3238, DISF is operating under the supervision of the Central Bank of the Republic of Turkey and under the responsibility of the Presidency of Defence Industries.

Land, Naval and Air Force Support Foundations, that were established different times before, were united as TAFF on 17 June 1987, with the Law No. 3388. The foundation started its operations, with the aim of enhancing the warfare of capability of TAF through national defence industry, establishing new defence industry areas and procuring warfare armament by providing the financial and spiritual support of Citizens, on 26 September 1987. As of 2020, the TAFF governs its 14 direct and indirect companies (six affiliate companies, six subsidiaries, and two indirect affiliate companies) within the concept of “Group of Companies”, according to Turk Silahlı Kuvvetleri Güçlendirme Vakfı's website.

With the decree-law No. 668, Gendarmerie General Command and the Coast Guard Command bounded to the Ministry of Interior on July 25, 2016.

Government/company loans are the loans by foreign countries and companies. Koseoglu (2010, p. 75) states that these kind of loans are provided either by foreign companies that supply the project or by international organizations on behalf of the government; its repayments are made by the government, or its financial guarantee is provided by Treasury.

FMS program is a form of security assistance authorized by the Arms Export Control Act (AECA), and an important of U.S. foreign policy. Under Section 3 of the AECA, the U.S. may sell defence articles and services to

Defence Expenditure and Financial Resources of Defence Expenditure in Turkey: A Comparative Conceptual Analysis

friendly foreign countries and international organizations. Countries in this program may obtain defence articles and services by paying with their own national funds or with U.S. Government funds. In certain cases, U.S. may give defence articles and services on a grant basis, as indicated by the website of Defence Security Cooperation Agency's.

The MSD has also a number of revenues determined by special laws, as well. Some of these can be expressed as revenues from "Military Service in Foreign Exchange" (under Laws No. 1111 and 3802) and sales of goods, services, and properties (under Laws No. 189 and 3212).

4. COMPARISON OF TURKEY'S DEFENCE BUDGET WITH OTHER COUNTRIES

After explaining the financial sources of defence expenditures in brief, in this section, we reveal the size of the defence market in Turkey and draw a comparison between the Turkey's defence budget with other selected countries.

4.1. Defining the Defence Budget

According to Hartmann and Wendzel (1990, p.31), defence planning, which is updated according to ongoing risk assessments, is a process that is affected by many factors such as threat perception, economy, resources, international partnerships, neighborhood relations, geographical position, political situation, technological power, population, cultural and traditional values, and attitudes of leaders, as specified by Berk (2015, p.8). The defence budget is determined in accordance with the mentioned planning.

Although there are many key factors, the most significant factor determining the amount of spending is the threat. Governments decide on the amount of defence expenditures in accordance with the existence of internal and external threats and the severity of threat. On the other hand, different causal drivers like strategic sources, political and economic relations, geopolitics and socio-economic structures should be considered when analyzing the threat.

In addition to this, mandatory defence spending levels, weapons control agreements and side income sources can play an active role in determining

*Mehmet Bilge Kağan ÖNAÇAN, Volkan SEZGİN, Tunç Durmuş MEDENİ,
İhsan Tolga MEDENİ*

the defence budget, according to the website of Geneva Centre for the Democratic Control of Armed Forces (2002). Here, it would be beneficial to open up especially the notion of *mandatory defence spending level*. As noted in the last section, some countries determine defence expenditure as a percentage of the current defence expenditure divided by GDP or this rate is calculated taking into account of the conditions of the alliance. For instance, all new NATO members are committed to spend 2% of GDP on defence.

Almost for every country, a national budget cycle determining the defence spending is effectuated annually and consists of four main stages namely budget preparation, budget approval, budget execution, and budget evaluation. Organization for Security and Co-operation in Europe (OSCE) has incorporated the following principle to 'Code of Conduct on Politico-Military Aspects of Security' document, as follows: Each participating State will provide for its legislative approval of defence expenditure. Each participating State will, with due regard to national security requirements, exercise restraint in its military expenditures and provide for transparency and public access to information related to the armed forces, as noted by Geneva Centre for the Democratic Control of Armed Forces (2002). Similarly, any expenditure made within the framework of the MND budget in Turkey is subject to the financial controls and supervisions of the government, Ministry of Treasury and Finance, Court of Accounts, and the MND.

The basis of Turkey's national defence, security strategies and policies is National Security Policy Document (NSPD) that is updated by National Security Executive Committee in every five years. In the direction of NSPD, Turkey's National Military Strategy (TNMS) document is being prepared. Preparing by taking into consideration the political situation, risk assessment and the policies regarding the use of the armed forces, Turkish national defence planning is a process that involves the works carried out in four successive phases in two years period: In the first phase, NMS is prepared. In the second phase, the Planning and Programming Directive (PPD) is arranged and published. In the third phase, the Strategic Target Plan (STP) is published. In the fourth phase, Ten-Year Procurement Plan and Program Budget Proposal is prepared and announced. According to

*Defence Expenditure and Financial Resources of Defence Expenditure in
Turkey: A Comparative Conceptual Analysis*

Mevlutoglu (2016, p. 17) and Muslum et al. (2010, p. 107), the implementation of the plan follows these four phases.

In the next part of our study, we focus on the defence expenditures which simply cause defence budgets to be generated, and the roles of the actors during this process are investigated. During the process of the realization of national defence, financial resources and budgets are required for the execution of activities, projects etc.

4.2. Definition of Defence Expenditure

Defence budgets are allocated to meet the defence expenditures. Giray (2004, p.184) underlines that the definitions of defence expenditure vary as there are different explanations by NATO, International Monetary Fund (IMF), United Nations (UN) and SIPRI, however in general, it can be stated that defence expenditure is the share that is allocated from country's national income in order to ensure the internal and external safety of a country, as noted by Onder (2009, p. 2661).

Considering that the data by SIPRI is up to date and well-respected, SIPRI's data have been utilized for the sake of the analysis. Following SIPRI's definition, defence expenditure includes all current and capital expenditure on:

- The armed forces, including peace keeping forces
- Defence ministries and other government agencies engaged in defence projects
- Paramilitary forces when judged to be trained, equipped and available for military operations
- Military space activities

Such expenditures should include personnel, operations and maintenance, procurement, military research and development, military construction, military aid and exclude military related expenditures such as civil defence and current expenditure for previous military activities (veteran benefits, demobilization, conversion of arms production facilities, destruction of weapons), as per SIPRI's official website.

4.3. Reasons and Factors of Defence Expenditure

One can claim that the last resort to the solution of the problems in international relations is the "military force". Military force is apparently an element of national power, and it has to be continuously improved. The governments, by no means, can give up supporting and providing this force. According to the traditional realist view, the possibility that a war can happen at any moment forces governments to be constantly alert and follow real politics in order to protect their national interests. Gurcan (2011, p.129) references the following: "Always being ready for war (si vis pacem para bellum)" is the only formula of peace and keeping order in the world.

From the early ages to the present day, people developed various weapons and defence methods to protect their lives, values and interests from danger; sometimes they defended themselves with these weapons and on occasions they attacked for some benefits. This has been valid nearly for all countries throughout the history. For centuries, international conflicts of interest have been present and weapons have been resorted as a last expedient to reach a solution as the military forces are directly engaged in this multilateral dilemma.

The armed forces that have direct and indirect effects in respect of external security have important repercussions in respect of internal security as well. Kucuksahin (2006, p. 12) mentions that in order to ensure the public peace and the government survival within the political boundaries of a country, governments take precautions via private security companies, its police, intelligence units and the armed forces, in addition to the social, political, economic and environmental measures.

The most important reason for defence spending is obviously a "threat". Countries obviously need to protect themselves against threats. Governments determine the amount of defence expenditures according to the existence and severity of the internal and external threats, while the strategy of the country is another crucial factor affecting military expenditures as the country's defence and/or attack strategies direct country's defence expenditures.

Defence expenditure, which impresses defence and attack, has deterrent effect at the same time as the strategic, political and economic effects of

Defence Expenditure and Financial Resources of Defence Expenditure in Turkey: A Comparative Conceptual Analysis

weapon systems go far beyond military influences as their range, coverage, size, and other attributes increase.

Because of the abovementioned reasons, governments have to allocate appropriate budgets for their defence expenditures. In the next section, Turkey's defence budget and expenditures are examined comparatively with other selected countries.

4.4. Defence Expenditure in the World

The demise of the Warsaw Pact in the late 20th century, the end of the Cold War plus the collapse of the Soviet Union created a new political and security understanding in the world. This has caused to considerations for the establishment of a lasting peaceful atmosphere in the world. However, after a while, developing technology, migrations, ethnic nationalism, money and population movements created by globalization, and increased terrorism activities have changed the world into a more uncertain and complicated place to live. Defence expenditures and budget allocated for defence in the world, which plummeted between 1987 and 1998, started to increase both globally and regionally since 1998, as can be seen in Table 1; based on the data compared on a yearly basis.

The figures show that defence expenditures are on the rise regularly, both locally and globally. We see that in the last 20 years, defence expenditure has increased by 2.9 times in Africa, by 1.6 times in United States of America, by 2.9 times in Asia and Oceania, by 1.3 times in Europe, and by 1.8 times in the world. In line with this, Dr. Nan Tian who works at SIPRI as a researcher, notes that "the global military spending in 2019 represented 2.2 per cent of the global GDP, which equates to approximately \$249 per person. Global military expenditure was 7.2 per cent higher in 2019 than it was in 2010".

Table 1. Regional defence expenditures in the world, 1998-2019
(billion \$, 2018 prices). (SIPRI database, 2020a).

Year	World	Africa	America	Asia and Oceania	Europe	Middle East
1998	1054	14,4	497	181	276	85,7
1999	1077	21	499	191	281	83,8
2000	1114	18,3	517	196	290	92,6
2001	1139	18,7	525	208	293	95,5
2002	1215	20,9	582	219	300	93
2003	1301	20,1	652	228	306	94,9
2004	1384	22,6	708	242	310	101
2005	1443	23,5	742	255	313	110
2006	1486	25,5	754	270	318	119
2007	1548	26,8	777	288	327	128
2008	1637	31,5	834	306	336	129
2009	1753	33,2	899	344	342	135
2010	1789	35,5	924	352	336	141
2011	1794	39,2	914	366	330	144
2012	1778	40,4	868	381	331	157
2013	1748	45,1	808	400	326	168
2014	1743	46,4	764	423	328	181
2015	1766	44,3	750	446	337	No Certain Data
2016	1779	43,3	747	467	351	No Certain Data
2017	1800	42,5	746	489	342	No Certain Data
2018	1849	41	768	507	348	No Certain Data
2019	1914	41,6	805	531	365	No Certain Data

Defence Expenditure and Financial Resources of Defence Expenditure in Turkey: A Comparative Conceptual Analysis

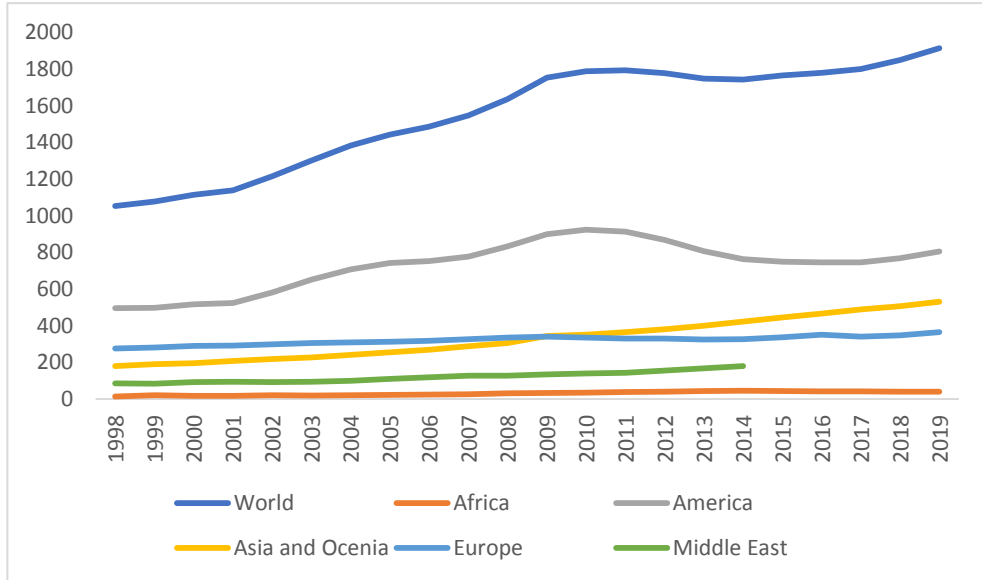

Figure 1. Regional defence expenditures in the World, Europe, Asia and Africa and America (billion \$, 2018 prices). (Authors' calculations using SIPRI database, SIPRI, 2020a and SIPRI, 2020b).

4.5. Comparison of Turkey's Defence Budget with Other Countries

For this section of the study, Turkey's defence budget is compared with countries, whose annual military budget is more than \$10 billion. Table 2 below demonstrates Turkey's stance among others. It appears Turkey ranks the 10th in the mentioned list.

Table 2. Defence budgets for countries whose military budget is more than \$10 billion, 2019 (billion \$ and % of GDP). (SIPRI database, 2020a, 2020b).

Country	Spending in 2019	Share of GDP, 2019 (%)
Saudi Arabia	\$61.87	8.0%
Algeria	\$10.30	6.0%
Israel	\$20.47	5.3%
Pakistan	\$10.26	4.0%
Russia	\$65.10	3.9%
U.S.A.	\$731.75	3.4%
Singapore	\$11.21	3.2%
Colombia	\$10.08	3.2%
South Korea	\$43.89	2.7%
Turkey	\$20.45	2.7%
India	\$71.13	2.4%
Iran	\$12.62	2.3%
Poland	\$11.90	2.0%
France	\$50.12	1.9%
China	\$261.08	1.9%
Australia	\$25.91	1.9%
Taiwan	\$10.42	1.7%
UK	\$48.65	1.7%
Italy	\$26.79	1.4%

*Defence Expenditure and Financial Resources of Defence Expenditure in
Turkey: A Comparative Conceptual Analysis*

Canada	\$22.20	1.3%
Netherlands	\$12.06	1.3%
Germany	\$49.28	1.3%
Spain	\$17.18	1.2%
Japan	\$47.61	0.9%

Today, there are major conflicts in the immediate vicinity of Turkey and the problems related to internal security within its borders have been going on for many years. Located in a highly strategic but inconsistent and unstable region, Turkey allocates a significant share of its limited resources to defence expenditures in order to protect its national interests, sustain its existence, and become a strong country in her region, according to Uslu (2007, pp. 115-116). This can be considered as one of the reasons why Turkey continues to allocate more of its resources to defence expenditures, particularly after 2015.

In order to define the burden of defence expenditure on a country's economy and/or the importance of defence for a country, investigating the defence expenditure as a share of GDP is a common method. We see that the defence expenditure is determined as a percentage of the current defence expenditure as a rate of GDP for various countries. According to data obtained from SIPRI 2020b's database, defence expenditure as a share of Turkey's GDP is presented in Figure 2. After 1998, the ratio of defence expenditure to GNP in Turkey seems to be in a decreasing tendency while this trend significantly reversed after 2015. Turkish defence spending as a share of GDP in 2015 was 1.8% but in increased to 2.7% in 2019, reflecting a 50% change in only 5 years.

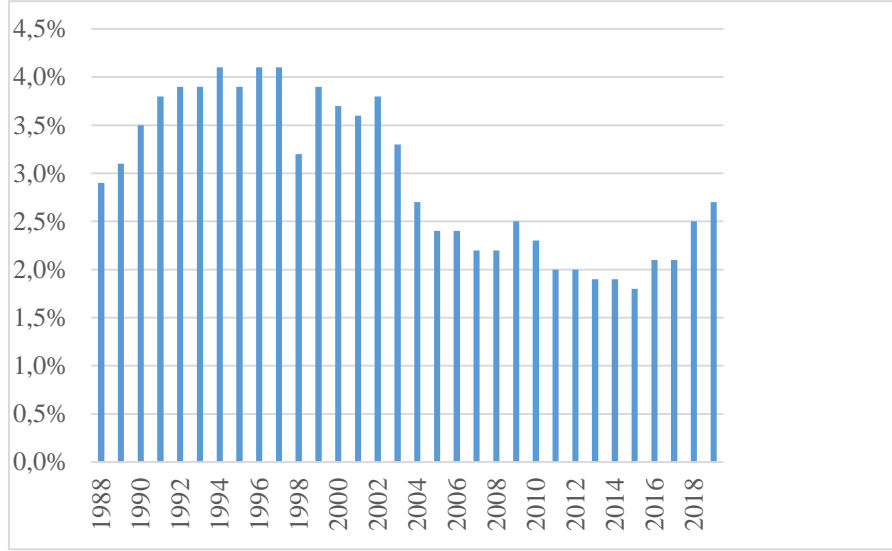

Figure 2. Defence expenditures as a share of Turkey's GDP, 1988-2019 (%). (Authors' calculations using SIPRI database, SIPRI, 2020a and SIPRI, 2020b).

After seeing defence expenditure trends in different parts of the world, we think that it would be useful to examine how these expenditures have occurred in Turkey's neighbors in order to make comparative evaluations. The comparison of defence expenditures, recorded between 2000 and 2019 in Turkey and its neighbors, are presented in Table 3. When the defence expenditures of each country are examined, it seems that the expenditure of every country is not stable on a yearly basis. However, it is recognized that there is a tendency to increase or decrease the spending in general. According to the figures obtained from SIPRI 2020b's database in the last 20 years, we found out that the defence spending rose by 62% and 145% respectively for Turkey and Bulgaria, plummeted by 29% and 55% respectively for Greece and Iran. The defence expenditures were rather less for Armenia and Georgia when compared with other countries. Our analysis shows that the expenditures by Armenia and Georgia increased by 308% and 861%, respectively. It should be noted here that since SIPRI did not

Defence Expenditure and Financial Resources of Defence Expenditure in Turkey: A Comparative Conceptual Analysis

release certain data for Syria and Iraq during the period under consideration, we excluded these two countries from our analysis.

Table 3. Defence expenditures of Turkey and Turkey's neighbors (% of GDP). (SIPRI's 2020b database).

Year	Turkey	Bulgaria	Greece	Iran	Iraq	Armenia	Georgia
2004	2,7	2,4	2,6	2,8	1,7	2,7	1,4
2005	2,4	2,3	2,8	3,0	2,2	2,9	3,3
2006	2,4	2,1	2,8	3,3	1,9	2,9	5,2
2007	2,2	2,2	2,7	2,7	2,2	3,0	9,2
2008	2,2	2,1	3,0	2,8	2,4	3,4	8,5
2009	2,5	1,7	3,2	3,2	2,9	4,2	5,6
2010	2,3	1,6	2,7	2,9	2,7	4,3	3,9
2011	2,0	1,3	2,5	2,4	2,3	3,9	3,2
2012	2,0	1,3	2,4	2,8	1,9	3,8	3,1
2013	1,9	1,5	2,4	2,2	3,3	4,0	2,7
2014	1,9	1,3	2,3	2,3	3,0	3,9	2,5
2015	1,8	1,3	2,5	2,8	5,4	4,2	2,1
2016	2,1	1,3	2,5	3,0	3,5	4,1	2,2
2017	2,1	1,2	2,5	3,1	3,9	3,8	2,1
2018	2,5	1,5	2,6	2,5	2,9	4,9	2,0
2019	2,7	3,2	2,6	2,3	3,5	4,9	2,0

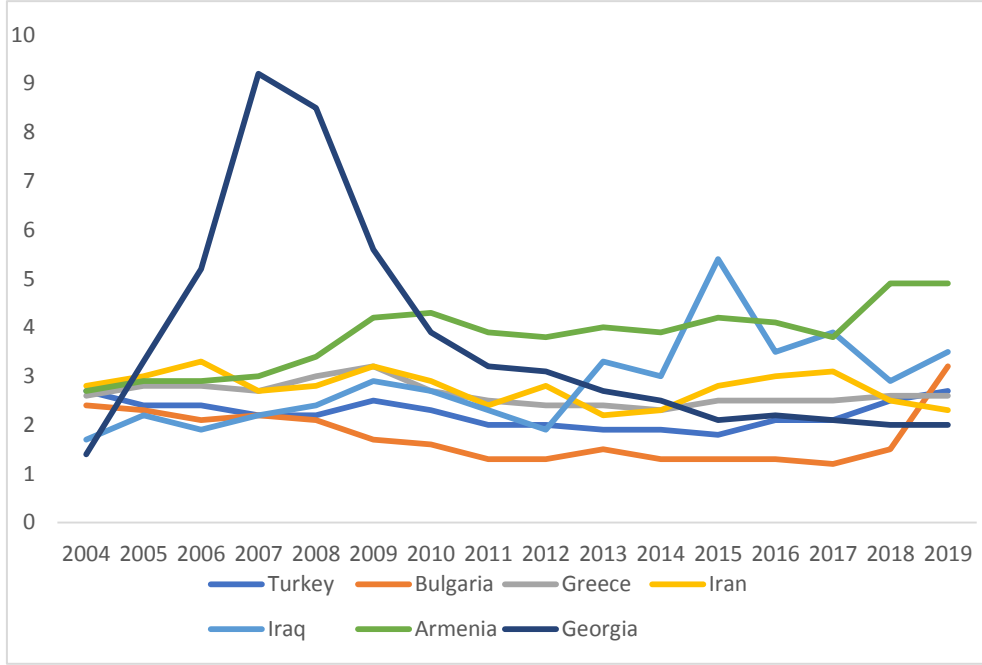

Figure 3. Defence expenditures of Turkey and Turkey's neighbors (% of GDP). (Authors' calculations using SIPRI database, SIPRI, 2020a and SIPRI, 2020b).

Although Turkey's defence expenditures out of its GDP have relatively increased in the recent years, it is less than that of Iraq's, Bulgaria's and Armenia's. When we examine the shares of expenditures out of GDPs in 2019 to reveal the burdens of defence spending on the countries' economies, we see that the ratio of defence expenditures to GDP in Turkey recorded as 2.7% in 2019, while the same ratio was 2.6% for Greece in the same time frame. Turkey's ratio is lower than that of Bulgaria (3.2% in 2019) and higher than Greek Cypriot Administration of Southern Cyprus (1.6%) and Iran (2.3% in 2019). Although Armenia's ratio was 4.9%, Turkey's ratio was higher than most of the other neighbors like Georgia (2%). No military expenditure data have been revealed for Syria and the figures related to Iraq are uncertain, according to SIPRI.

Defence Expenditure and Financial Resources of Defence Expenditure in Turkey: A Comparative Conceptual Analysis

One of the restrictions of comparing Turkey's defence expenditures with its neighbors' is that both the size of the countries and army personnel differ to a large extent from each other. Besides, among these countries, only Turkey and Greece are the members of NATO, which require additional obligations and expenses. Turkey and Greece are also spending a lot for the peacekeeping operations outside of their territories.

5. CONCLUSION

Countries allocate substantial resources to their defence industries and allocate huge defence budgets. Geopolitical situation, strategic interests of the country and especially threat perception make defence expenditures, - which generally have significant shares in the country's budget and affect social welfare negatively- mandatory.

When the ratios of defence expenditures as a share of GDP are analyzed, it is seen that Turkey's defence expenditures are almost at world averages but inclined to increase after 2015 like the averages of Asia and Europe. According to data gathered from SIPRI 2020a and 2020b's database, Turkey ranked the 15th with a defence budget of 20.4 billion dollars among the list of countries with the most defence budgets 2019. Turkey's ratio of defence spending to GDP in 2019 was 2.7%. Also, when Turkey's defense budget is compared with its neighbors as of 2019, it is viewed to be at an average value. Turkey spends more than average of its neighbors quantitatively, but when the GDP ratio is considered, it is seen that it has been less than average in the recent years. Although there are areas to be improved, it is seen that there is a systematic application related to the determining, planning, implementing and checking of defence expenditure and reasonable defence expenditure is defined according to this systematic in Turkey. For future work, countries which have similar economic characteristics to Turkey can be defined and comprehensive comparisons can be made accordingly.

Defence Industry Support Fund (SSDF), which aims to provide continuous and stable resources to investments to be made in weapons production areas, and Turkish Armed Forces Foundation (TSKGV) that aims to provide financial contribution to the TAF with revenues such as financial incomes,

*Mehmet Bilge Kağan ÖNAÇAN, Volkan SEZGİN, Tunç Durmuş MEDENİ,
İhsan Tolga MEDENİ*

profit share incomes, donation incomes, rental incomes and fair incomes, are other significant financial resources of defence expenditures in Turkey.

As a result, it is evaluated that it is not possible to claim that the defence budget in Turkey is overblown when internal and external threats, defence expenditures in neighbor countries, deterrence, contribution to regional stability, the alliance conditions and domestic control mechanisms are considered. On the other hand, it is considered usual to make improvements in the processes of forming both the country budget and the defence expenditures and the effectiveness of the domestic control mechanisms.

It is also evaluated that it is not possible to cut down the expenditures of TAF in order to continue both deterrence and contribution to regional stability, when the conjuncture (issues related to Aegean islands, eastern Mediterranean, Cyprus, Egypt, Syria, Iraq, terrorist organizations etc.) is taken into consideration. However variations in Turkish defence expenditures might occur due to threat perception, economy, resources, international partnerships, neighborhood relations, geographical position, political situation, technological power, population, cultural and traditional values, and attitudes of leaders. Conflicts of interest in the world have been going on for many years. As long as conflicts of interest continue, the need for high defence budgets will continue to exist.

*Defence Expenditure and Financial Resources of Defence Expenditure in
Turkey: A Comparative Conceptual Analysis*

ACKNOWLEDGEMENT

This study is the extended version of the study which is titled as "Defence Expenditures and Financing Sources of Defense Expenditures in Turkey", was presented at the Social Sciences Research Conference (SOSBİLKO 2017) held on November 23, 2017 at the Esenboga Central Complex of Ankara Yıldırım Beyazıt University (AYBÜ) and whose summary was published in the abstracts proceedings book of the conference.

The views expressed here are solely authors' and do not necessarily reflect those of their affiliations.

CONFLICT OF INTEREST STATEMENT

The authors declare no conflict of interest.

REFERENCES

- Akyesilmen, N. (2006). "Yasama: Türkiye Büyük Millet Meclisi". Ali Bayramoğlu and Ahmet Insel (Eds.), *Almanak Türkiye*, Vol. 2008, pp. 15-22.
- Basar, S., & Kunu, S. (2012). "Savunma Harcamalarının İktisadi Büyüme Etkisi". *Journal of Institute of Social Sciences*, Vol. 10, pp. 1-30.
- Berk, U. (2015). "Stratejik Savunma ve Güvenlik Planlamasında Ortak Bir Yaklaşım Olarak Senaryo Temelli Planlama". *Güvenlik Bilimleri Dergisi*, Vol. 4:2, pp. 1-36.
- Brzoska, M. (1995). "World Military Expenditures". Keith Hartley and Todd Sandler (Eds.), *Handbook of Defence Economics*, Vol. 1, pp. 45-67.
- Defence Security Cooperation Agency (n.d.). Retrieved from <http://www.dsca.mil>
- Geneva Centre for the Democratic Control of Armed Forces (DCAF) (2002). "Democratic Control of Armed Forces: The National and International Parliamentary Dimension". Retrieved from <https://www.dcaf.ch/democratic-control-armed-forces>
- Giray, F. (2004). "Savunma Harcamaları ve Ekonomik Büyüme". *Cumhuriyet Üniversitesi İİBF Dergisi*, Vol. 5:1, pp. 181-199.
- Gurcan, M. (2011). "Bir Önceki Savaş İçin Hazırlanmak: Değişen Küresel Güvenlik Ortamının Geleneksel Savaş Olgusuna Etkisi". *Bilge Strategy: Geopolitics, Economy-Political and Socio-Cultural Studies Journal*, Vol. 3:5, 127-178.
- Habertürk (2015). "Cumhurbaşkanı Erdoğan Savunma Sanayi Fuarı'na Katıldı". Retrieved from <http://www.haberturk.com/ekonomi/teknoloji/haber/1073866-cumhurbaskani-erdogan-savunma-sanayi-fuarinda>
- Hartmann, F., & Wendzel, R. (1990). *Defending America's Security*, Brassey's Inc.

Defence Expenditure and Financial Resources of Defence Expenditure in Turkey: A Comparative Conceptual Analysis

Koseoglu, A. M. (2010). *Milli Savunma Sanayiinde Yeniden Yapilanma ve Sosyal Politikalara Etkisi* [Doktora Tezi]. Dokuz Eylül Üniversitesi, Sosyal Bilimler Enstitüsü.

Kucuksahin, A. (2006). "Güvenlik Bağlamında, Risk ve Tehdit Kavramları Arasındaki Farklar Nelerdir ve Nasıl Belirlenmelidir?" *Journal of Security Sciences*, Vol. 4, pp. 7-40.

Lifshitz, Y. (2003). *The Economics of Producing Defence*. Kluwer Academic Publishers.

Mevlutoglu, A. (2016). *Türkiye'nin Savunma Reformu Tespit ve Öneriler*. Seta Yayınları, İstanbul.

Ministry of National Defence. (n.d.). "Milli Savunma Bakanlığı Savunma Tedarik Terimleri Sözlüğü (Türkçe-İngilizce)". Retrieved from <http://www.msb.gov.tr/Content/Upload/Docs/modernizasyon/terimlersozlugu07082009.doc>

Muslum, S., Topcu, M. K., and Mala, M. (2010). "Savunma Tedarikinde Güncel Yaklaşımlar: Evrimsel Tedarik Stratejisi ve Türkiye Açısından Bir Değerlendirme". *Savunma Bilimleri Dergisi*, Vol. 9:2, pp. 91-115.

Nemli, A. (1990). *Introduction to Public Finance*. Filiz Bookstore, İstanbul.

Official Gazette's Webpage (2018). "Presidential Decree No. 4, Bakanlıklara Bağlı, İlgili ve İlişkili Kurum ve Kuruluşlar ile Diğer Kurum ve Kuruluşların Teşkilatı Hakkında Cumhurbaşkanlığı Kararnamesi". Retrieved from <https://www.resmigazete.gov.tr/eskiler/2018/07/20180715-1.pdf>

Official Gazette's Webpage (2018). "Presidential Decree No. 1, Cumhurbaşkanlığı Teşkilatı Hakkında Cumhurbaşkanlığı Kararnamesi". Retrieved from <https://www.resmigazete.gov.tr/eskiler/2018/07/20180710-1.pdf>

Official Gazette's Webpage (2018). "Presidential Decree No. 7, Savunma Sanayii Bakanlığı Hakkında Cumhurbaşkanlığı Kararnamesi". Retrieved from <https://www.resmigazete.gov.tr/eskiler/2018/07/20180715-4.pdf>

*Mehmet Bilge Kağan ÖNAÇAN, Volkan SEZGİN, Tunç Durmuş MEDENİ,
İhsan Tolga MEDENİ*

Official Webpage of Presidency of Defence Industries. “Savunma Sanayi Mustesarligi Faaliyet Raporu 2015”. Retrieved from https://www.ssm.gov.tr/Images/Uploads/MyContents/V_20170726145139240337.pdf

Onder, K. (2009). “Turkiye’de Savunma Harcamalarının Ekonomiye Etkisi Uzerine Bir Arastirma”. *International Davraz Congress*, pp. 2660-2671.

Sandler, T., & Hardley, K. (1995). *The Economics of Defence*. Cambridge University Press.

Stockholm International Peace Research Institute (SIPRI) (n.d.). “SIPRI Definition of military expenditure”. Retrieved from http://www.sipri.org/research/armaments/milex/milex_database/definitions

Stockholm International Peace Research Institute (SIPRI) (2020a). “Military expenditure by region in constant US dollars”. Retrieved from <https://www.sipri.org/sites/default/files/Data%20for%20world%20regions%20from%201988%E2%80%932019.pdf>

Stockholm International Peace Research Institute (SIPRI) (2020b). “Military expenditure by country as percentage of gross domestic product, 1988-2019”. Retrieved from <https://www.sipri.org/sites/default/files/Data%20for%20all%20countries%20from%201988%E2%80%932019%20as%20a%20share%20of%20GDP.pdf>

The World Bank (n.d.). “GDP Indicators”. Retrieved from <https://data.worldbank.org/indicator/NY.GDP.MKTP.KD>

Turk, H. K. (2007). *Turk Savunma Sanayiinin Ekonomik Etkileri ve Savunma Harcamaları-Buyume Iliskisinin Ekonometrik Modellenmesi* [Yuksek Lisans Tezi]. Cukurova Universitesi, Sosyal Bilimler Enstitusu.

Turk Silahlı Kuvvetleri Guclendirme Vakfi (n.d.). “İştiraklerimiz”. Retrieved from <https://www.tskgv.org.tr/tr/ortakliklarimiz/istiraklerimiz>

Turk Silahlı Kuvvetleri Guclendirme Vakfi (n.d.). Retrieved from www.tskgv.org.tr

Defence Expenditure and Financial Resources of Defence Expenditure in Turkey: A Comparative Conceptual Analysis

Uslu, F. S. (2007). *Turkiye’de Savunma Sanayii Harcamalarının Finansmanı* [Yüksek Lisans Tezi]. Ankara Üniversitesi, Sosyal Bilimler Enstitüsü.

Uysalkan, I. I. (2010). *Milli Savunma İskolunda Çalışma Kosulları*. [Doktora Tezi]. Dokuz Eylül Üniversitesi, Sosyal Bilimler Enstitüsü.

Yenturk, N. (2014). “Measuring Turkish Military Expenditure”. *SIPRI Insights on Peace and Security*. No. 2014/1, pp. 1-19.

Ziylan, A., Batmaca, S., Por, R., Uysal, I., Zaim, M., Tatar, Y., and Er, U. (1998). “Savunma Sanayii ve Tedarik: Ülkemizin Bilim ve Teknoloji Yeteneğinin Yükseltilmesini Esas Alan Bir Yaklaşım”. *Bilim ve Teknoloji Strateji ve Politika Çalışmaları*, TÜBİTAK BTP.

**An ethical committee approval and/or legal/special permission has not been required within the scope of this study.*

**SUPERVISED MACHINE LEARNING-BASED CLASSIFICATION
OF NETWORK THREATS/ATTACKS AGAINST COMPUTER
SYSTEMS***

Ercan KURU¹
Tolga ÖNEL²
Mehmet Bilge Kağan ÖNAÇAN³
Musa MILLİ⁴

¹*National Defence University, Barbaros Naval Sciences and Engineering
Institute, Department of Cyber Security, Istanbul, Turkey;*
kru.ercn@gmail.com; ORCID: 0000-0001-8359-5684

²*HAVELSAN, Department of Command Control and Defence Technologies,
Istanbul, Turkey;*
onel.tolga@gmail.com; ORCID: 0000-0002-3256-8122

³*Istanbul Okan University, Faculty of Applied Sciences, Department of
Information Systems and Technology, Istanbul, Turkey;*
mbko@yahoo.com; ORCID: 0000-0002-7147-0945

⁴*National Defence University, Turkish Naval Academy, Department of
Computer Engineering, Istanbul, Turkey;*
mmilli@dho.edu.tr; ORCID: 0000-0001-8323-6366

Received: 28.11.2021

Accepted: 31.01.2022

Ercan KURU, Tolga ÖNEL, Mehmet Bilge Kağan ÖNAÇAN, Musa MİLLİ

ABSTRACT

With the developing technology, number of people who use computers are increasing nowadays. This increase in computer usage causes an increase in the variety of attacks and the number of attacks against computer systems. This situation reveals the importance of the protection of data processed on the computers and the concept of information security. Thanks to the intrusion detection systems, which have an important place in the protection of computer systems, attacks against computers and computer networks can be detected before they affect systems. Considering the increasing variety of attacks, the development of machine learning-based attack detection systems has been the subject of many studies recently. Although supervised and unsupervised machine learning have separate features, they make different contributions to the areas in which they are used. Within the scope of this study, NSL KDD data set, one of the most frequently used data sets in previous studies to simulate network traffic, was applied to a number of supervised and unsupervised learning algorithms in the WEKA application. When the results are evaluated under certain criteria, it has been determined that supervised learning algorithms give more accurate results, where unsupervised learning algorithms give faster results in the detection of attacks.

Keywords: *Intrusion Detection System, Supervised Learning, Unsupervised Learning, Information Security, Dimensionality Reduction.*

**BİLGİSAYAR SİSTEMLERİNE YÖNELİK AĞ TABANLI
TEHDİTLERİN/SALDIRILARIN DENETİMLİ YAPAY ÖĞRENME İLE
SINIFLANDIRILMASI**

ÖZ

Gelişen teknoloji ile birlikte günümüzde bilgisayar kullananların sayısı artmaktadır. Bilgisayar kullanımındaki bu artış, bilgisayar sistemlerine yönelik saldırıların çeşitliliğinin ve sayılarının artmasına neden olmaktadır. Bu durum, bilgisayarlarda işlenen verilerin korunmasının ve bilgi güvenliği kavramının önemini ortaya koymaktadır. Bilgisayar sistemlerinin korunmasında önemli bir yere sahip olan saldırı tespit sistemlerinin çalışma prensibi sayesinde bilgisayarlara ve bilgisayar ağlarına yönelik saldırılar sistemleri etkilemeden tespit edilebilmektedir. Artan saldırı çeşitliliği göz önüne alındığında, yapay öğrenme ile saldırı tespit sistemlerinin geliştirilmesi son zamanlarda birçok araştırmaya konu olmuştur. Denetimli ve denetimsiz yapay öğrenme ayrı özelliklere sahip olsa da kullanıldıkları alanlara farklı katkılar sağlamaktadırlar. Bu çalışma kapsamında, WEKA uygulaması kullanılarak bir takım denetimli ve denetimsiz öğrenme algoritmaları, ağ trafiğini simüle etmek için önceki çalışmalarda en sık kullanılan veri setlerinden biri olan NSL KDD veri setine uygulanmıştır. Sonuçlar değerlendirildiğinde, saldırı tespitinde denetimli öğrenme algoritmalarının daha doğru, denetimsiz öğrenme algoritmalarının ise daha hızlı sonuç verdiği tespit edilmiştir.

Anahtar Kelimeler: *Saldırı Tespit Sistemi, Denetimli Öğrenme, Denetimsiz Öğrenme, Bilgi Güvenliği, Boyut Azaltma.*

1. INTRODUCTION

Internet and computer usage is getting more widespread nowadays and we encounter these two definitions in almost every area of our lives. According to the data of March 2021, 66% of nearly eight billion people living on earth use the internet. Depending on the increasing internet usage, the number of malicious software is increasing and diversifying every day. Thus, the information stored/processed on the computer or computer networks and the security of this information appear as a very important issue.

Many institutions/organizations around the world try to find some solutions by developing software and methods to ensure information security. The reliability and the performance of these solutions are the main reasons why users prefer these solutions. Malicious software causes other software running on the computer to behave differently than they should be, or damages the software that it affects (Kramer & Bradfield, 2009). Software using for ensuring information security varies depending on the type of malicious software. For example; while antivirus programs are used against malicious software such as viruses and trojans, anti-spyware software can be used against spyware.

Security of computer networks consisting of more than one computer is provided by intrusion detection systems. Intrusion detection systems examine the behavior of network traffic and determine whether the incoming data is malicious or not. Network traffic behavior is classified with developed algorithms. At this stage, machine learning comes into play. Machine learning algorithms form the basis of intelligent systems used in many areas of our lives. They can be expressed by analyzing the problem encountered by the software programmed in the computer system based on a specific data set or previous experiences (Alpaydm, 2010).

Machine learning is generally examined under three headings as Supervised Machine Learning, Unsupervised Machine Learning and Reinforcement Learning (Simeone, 2018). The data are processed by using the learning type according to the problem and the results are evaluated. There are many articles about classification of threats/attacks against computer systems but, in our study, we use both supervised and unsupervised machine learning algorithms and also dimensionality reduction to classify threats/attacks against computer systems. In this article, the machine learning algorithm that should be used in order to develop a better and effective intrusion detection system was tried to be determined by using NSL KDD

*Supervised Machine Learning-based Classification of Network Threats/Attacks
Against Computer Systems*

dataset derived from KDD CUP-99 dataset and WEKA application. The remainder of this paper is organized as follows. Section 2 gives information about the concept of knowledge, specifically, the definition and applications of information security. Section 3 and 4 examine the intrusion detection systems and machine learning respectively. Section 5 gives information about the algorithms and test setup. In Section 6, test results are evaluated. Finally, in Section 7, conclusion and discussion of this study are presented.

2. KNOWLEDGE AND INFORMATION SECURITY

Before knowledge, we should explain “data” and “information” first. “Data” are values collected by sensors, consisting of various symbols, letters, numbers and signs and that do not make sense in itself. “Information” is a collection of processed and meaningful data. Thus, “knowledge” is the inferences from information that has become conceptual (Avcı & Avcı, 2004; Bellinger et al., 2004; Kocabıyık, 2005; Kurgun, 2006; İltter, 2011; Önaçan, 2015).

Information is the processed form of data. Data and information show what anyone knows. Knowledge is the conceptual state of information. It shows how anyone knows. The most valuable asset today is the information. There are institutions and organizations operating in many fields from storing, processing and ensuring the security of information. Before the age of technology, the information was transferred from generation to generation, either verbally or in writings, can now be transferred from society to society very easily with computers and the internet.

Although easy access to information is an advantage, reaching accurate and reliable information and ensuring the security of information is currently the focus of many studies. Information that used to be kept in cabinets is nowadays stored in computers and even huge servers thanks to cloud computing. This situation reveals how important the security of information processed on computers and computer networks is. As a matter of fact, today many institutions and organizations take various measures to ensure information security.

Information security is the protection of information and information systems against unauthorized access, unauthorized use, unauthorized alteration and removal (Andress, 2011). As can be understood from the definition of information security, any activity aimed at changing and eliminating the real form of information covers the issue of information security.

In order to ensure information security, confidentiality must be provided, integrity must be maintained, and information must be available where information is processed. These three elements that constitute the basis of information security, form CIA (Confidentiality-Integrity-Availability) triangle, which is shown in Figure 1 (Solomon & Chapple, 2005).



Figure 1. CIA triangle.

The purpose of confidentiality is to prevent information from falling into unauthorized hands. Integrity deals with detection of and prevention from the unauthorized change of information. The purpose of integrity is to keep information as it should be. Availability means that information is always available. The purpose of availability is that users can access the data they want to access whenever they want within their authority.

Carnegie Mellon University, with its study (Figure 2), reveals that despite the increasing difficulty in techniques used in attacks against information security, the attacker's knowledge level has decreased (Allen et al., 2000).

Supervised Machine Learning-based Classification of Network Threats/Attacks Against Computer Systems

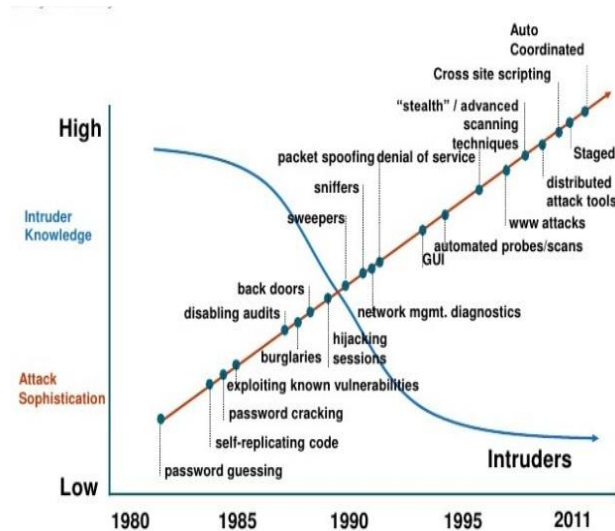

Figure 2. Attack sophistication vs. intruder technical knowledge.

Variety of attacks increases day by day as in Figure 2. Moreover, the level of knowledge required to carry out these increasing attacks tends to decrease. This situation forces computer users to take various measures. It is of great importance to ensure information security, especially in institutions and organizations. In this context, a world standard was established for the first time in 2005 by the International Standards Organization (ISO) and the International Electrotechnical Commission (IEC). The ISO/IEC 27001 standard specifies the requirements for the establishment, implementation, maintenance and continuous improvement of the systems that ensure information security (Ersoy, 2012). The standard was last updated in 2013, and it is a document used in activities carried out to ensure information security today.

3. INTRUSION DETECTION SYSTEMS

Intrusion detection refers to the detection of any attacks on computer systems and information security. Protection from attack, on the other hand, refers to the response to the attack in addition to the detection of the attack. Intrusion detection is the first step to protect against vulnerabilities. Intrusion detection systems detect attacks by collecting information from various systems and network sources and analyzing the data they collect (Taher et al., 2019). Considering the history of

intrusion detection systems, it is seen that the early studies in this subject coincides with the 1960s (Yost, 2016).

Intrusion detection systems have started on the basis of a single computer and have become to protect the whole network system that contains many devices today. Some sources of motivation in the development of attack detection systems are in the following:

- New network systems are complex and as a result they are prone to failure. These errors can also be used by malicious people.
- The network systems have some important defensive deficiencies, which makes the network systems the target of attackers. Although these deficiencies are tried to be covered with some tools and methods, it is not possible to completely eliminate the deficiencies.
- Although there are systems for protection from attack in network systems, full protection may not be possible. As a result, the need for intrusion detection systems is increasing.
- New types of attacks are constantly being developed for protection and detection systems. Thus, a dynamic structure that constantly learns and renews itself is needed for security solutions (Karataş et al., 2018).

Intrusion detection systems analyze and predict users' behavior to determine whether the behavior is an attack or a normal behavior. Intrusion detection systems are generally examined in two sections as Network Based Intrusion Detection Systems and Host Based Intrusion Detection Systems.

Network based intrusion detection systems examine network traffic using basic network packets to detect suspicious situations. Network packets are classified in three ways. In the string signatures method, the data related to the event, which may occur in the packet data, are examined, while in the port signatures method, it is checked whether there is any network traffic different from the relevant gates. In the header signatures method, the headers of the incoming network packets are examined and it is checked whether there is an unreasonable or possibly dangerous request (Liu, 2014).

It is possible to list the advantages and disadvantages of network based intrusion detection systems as follows. Since such systems use network packets for intrusion

*Supervised Machine Learning-based Classification of Network Threats/Attacks
Against Computer Systems*

detection and network data is a form of internet protocol (IP) packets, they can operate independently of the platform and operating system. The use of network packets in the detection of attacks brings early and rapid detection in case of possible attack. In addition, it does not affect the computer performance of the system it is in. Network based intrusion detection systems do not work effectively in case of ordinary excessive network traffic and may have difficulties in detecting network traffic consisting of encrypted data packets.

On the other hand, host based intrusion detection systems control data on a single computer. Examples of audited data include operating system calls, events, resource usage, and system logs. Any incompatibility or unusual behavior that may occur in these data is tried to be determined (Liu, 2014).

When we examine the advantages and disadvantages of host based intrusion detection systems, these systems enable us to have an idea of whether the attacks are successful or not, and to control the access activities of the user/files and the changes that may occur in the system files. However, host based intrusion detection systems are weaker in real-time response to attacks and against large-scale attacks.

4. MACHINE LEARNING

Machine learning can simply be defined as solving a problem faced by a computer program using previous experiences and data sets defined in that program. To decide whether a problem can be solved by machine learning methods or not, below criteria must be examined:

- The need for functions that lead from well-defined inputs to specific results;
- The need for very large data sets to solve the problem;
- The need for feedback containing clearly defined goals and data;
- Requirement of a detailed explanation of how the decision was made in order to reach the result;
- The solution to the problem does not need the most appropriate solution that is tolerant and provable for the error;
- Special hand skills, physical skills or no need for mobility to solve the problem (Brynjolfsson & Mitchell, 2017).

According to the learning method, machine learning is examined under three sections. Namely, Supervised Machine Learning, Unsupervised Machine Learning and Reinforcement Learning. In supervised machine learning, a function that correlates labeled input values with desired output values is learned. In unsupervised machine learning, a function is learned by using unlabeled data. In reinforcement learning, the learner tries to find the style of action that maximize the output according to the feedback it receives by interacting with the environment.

Supervised machine learning can be explained by the example of a student that learns a subject he/she does not know with the help of his/her teacher. The teacher knows the subject to be taught and what his/her student will learn. By feeding the labeled data set to the learning algorithm, it is "taught" to establish the relationship between the input and output of the algorithm. The trained algorithm performs its subsequent operations in the light of the learned function.

In supervised machine learning, the training set with known inputs and outputs can be thought as a teacher in the learning process. Hence, learning with a teacher is called as the supervised learning. Training process continues until the outputs of the machine algorithm reach to an acceptable level of accuracy (Brownlee, 2017). After this learning stage, the unprecedented data are categorized the algorithm according to the what has learned before.

Supervised learning algorithms are categorized into main classes. Namely the classification algorithms and regression algorithms. Classification algorithms decide which class or category the data sample belongs to. Regression algorithms, establish a relationship between the input data sample and the related output.

Unlike the supervised machine learning, in unsupervised machine learning, there is no "taught" and "labeled" data and the algorithm performs its own learning. In unsupervised machine learning, the algorithm creates a learning pattern for itself by using the features in the input data set. In the learning process unsupervised learning does not need a teacher as in the supervised learning.

Unsupervised learning algorithms are generally classified into two subclasses. These are clustering and association algorithms. Clustering algorithms cluster the data set given as input according to their characteristics, while association algorithms separate the features in the data set by establishing relationships. In Table 1, supervised and unsupervised learning algorithms are compared in terms of their definitions, applications and results.

*Supervised Machine Learning-based Classification of Network Threats/Attacks
Against Computer Systems*

Table 1. Supervised vs. unsupervised learning algorithms.

Parameter/ Benchmark Feature	Supervised Learning Algorithm	Unsupervised Learning Algorithm
Input Data	Labeled	Unlabeled
Purpose	To obtain a function that can predict the output of the given data different from the training set	Finding possible structures and hidden models in the input data set
Computational Complexity	Simple	Complex
Data Usage	Connects inputs and outputs	Does not use output data
Accuracy of Results	High reliability and accuracy	Low reliability and accuracy
Number of Classes	The number of classes used is determined	The number of classes used is uncertain
Usage Areas	Pattern recognition in picture and sound files, financial analysis, training of neural networks	Pre-training of raw data processing, data analysis, supervised learning algorithms

Considering the developing technology and the need for machine learning, both supervised learning algorithms and unsupervised learning algorithms are evolving and differentiating day by day. When compared to the unsupervised learning algorithms, supervised learning algorithms produce more accurate results with the light of labeled datasets. Unsupervised learning algorithms are good at investigating the correlations in the input data set.

5. ALGORITHMS AND TEST SETUP

In order to develop a better and more effective intrusion detection system by classifying threats and attacks against network-based computer systems, performances of the supervised and unsupervised machine learning are investigated using the NSL KDD dataset and WEKA application.

5.1. Review of Dataset

KDD CUP-99 data set is the version of the dataset developed by DARPA in 1998 (Ferrag et al., 2020). NSL KDD dataset is the compiled version of KDD CUP-99 dataset. NSL KDD data set is frequently used by researchers today and consists of "KDDTest", "KDDTest-21", "KDDTrain_20Percent", "KDDTrain" sub-sets (Dhanabal & Shantharajah, 2015).

There are three main features that distinguish the NSL KDD dataset from the KDD CUP-99 dataset and cause users to choose it. The first of these features is that the data in the KDD CUP-99 dataset, that mislead the classification algorithms, are reduced in the NSL KDD dataset. Thus, the margin of error is reduced while the classification algorithms are run. Secondly, the data in the NSL KDD dataset with different difficulty levels in terms of attack detection is inversely proportional to the data in the KDD CUP-99 dataset. This feature causes the classification rates of different machine learning algorithms applied with the NSL KDD dataset to spread over a wide range and this situation is beneficial for the users in terms of correctly evaluating the results of different algorithms. The third and last feature is that the number of training and test data in the NSL KDD data set is reduced compared to the KDD CUP-99 data set. This feature allows users to work on the entire data set without having to select any part of the data set (Chae et al., 2013).

The traffic data labeled as attack in the NSL KDD dataset consists of thirty-nine attack types evaluated in four classes in total. The first of the traffic data tagged as attack in the NSL KDD dataset is the "Denial of Service (DoS)" attack, the second is the "User to Root (U2R)" attack, the third is the "Remote to Local (R2L)" attack and the fourth is the "Probing" attack.

Denial of Service attack aims to use computer resources more than normal, and computers exposed to this attack type become unable to respond to users' demands. In the User to Root attack, attackers aim to be a privileged user (root, administrator, etc.) in the system. In the Remote to Local attack, they aim to use vulnerabilities in the local machine with the data they send over the network. In probing attacks, network traffic is examined, data is collected about computers and an attack is developed according to the detected weak points (Thomas & Pavithran, 2018).

5.2. Introduction of WEKA Application

WEKA (Waikato Environment for Knowledge Analysis) is a Java-based data processing and analysis program developed by Waikato University in New Zealand. The program began to be developed in 1993 with the support of the New Zealand government and was first available worldwide in 1999. The modular and extensible structure of the WEKA application allows users to quickly experiment and compare different machine learning methods with different data sets (Witten et al., 2009).

Data can be uploaded to the WEKA application from the database, over the internet (URL) and from the file. The program supports many file formats such as CSV and LibSVM with the ARFF format produced for it. In addition, thanks to the visual interface it offers, users can display their operations with graphics.

5.3. Data to Be Used in the Evaluation of Application Results

The evaluation of machine learning algorithms is made using variables in the confusion matrix. Four variables, called True Positive, True Negative, False Positive and False Negative, form the basis of the calculations to decide which supervised learning algorithm is better. The evaluation criteria of confusion matrix are shown in Table 2 (Nguyen & Armitage, 2008). Diagonal cells in the confusion matrix show the number of correctly detected data, while the other cells show the number of false detections (Deshmukh et al., 2015).

Table 2. Confusion matrix evaluation criteria.

Confusion Matrix		Predicted Class	
		A	\bar{A}
Real Class	A	True Positive	False Negative
	\bar{A}	False Positive	True Negative

- True Positive (TP) is the number of data that actually belong to class A and are predicted to belong to class A.
- True Negative (TN) is the number of data that do not actually belong to Class A and are predicted to not belong to Class A.
- False Positive (FP) is the number of data that do not actually belong to Class A but are predicted to belong to Class A.
- False Negative (FN) is the number of data that actually belong to Class A but are predicted not to belong to Class A.

Using these four variables, data such as Accuracy, Precision, Recall and F-measure are calculated. Thus the performance evaluation of supervised learning algorithms is performed (Kaya, 2016; Yiğidim, 2012). Accuracy is expressed as the ratio of correctly estimated data to total data. It is an important criteria that reveals the performance of the classification algorithm. Precision is the ratio of correctly predicted data to the total number of predicted data. Recall is the ratio of correctly predicted data to the actual number of data belonging to that class. It shows at what rate the algorithm correctly predicts the data. F-measure is calculated by taking the harmonic average of the precision and recall data. Therefore, instead of using both data separately, a comparison of supervised learning algorithms can be made by using this data.

5.4. Application of Supervised and Unsupervised Learning Algorithms

In order to use supervised and unsupervised learning algorithms with the WEKA application, we perform some pre-processes on the data set. These processes are explained below.

As a matter of fact, the NSL KDD data set contains three types of data (Nominal, Numerical and Binary) and two values as "Normal" and "Anomaly" as data label. In this study, in order to obtain results that close to the real situation, these label data were converted to five values as "Normal", "DoS", "U2R", "R2L" and "Probing" for both training and test data. Likewise, data types in the data set have been converted into suitable types for the algorithm used.

To examine the effect of algorithm performances on the entire NSL KDD dataset and on the reduced data, dimensionality reduction is applied to data set attributes and reduced to six attributes. The variance of the aforementioned six attributes is

0.90. That variance means that 125973 data in the data set can be expressed with six attributes with the rate of 0.90.

WEKA application uses four different methods for model creation and testing processes: “use training set”, “supplied test set”, “k-fold cross-validation” and “percentage split”. The most preferred method among these four methods is the “k-fold cross-validation” method (Kohavi, 1995).

With “k-fold cross-validation” method, the training data set given to the WEKA application is divided into k parts, one part is used for testing and the other parts are used to create a model, and the process is repeated k times. During this study, the data set with forty-one attributes and the data set with six attributes, as a result of the dimensionality reduction process, were used with “k-fold cross-validation” and “supplied test set” methods while testing the below-mentioned machine learning algorithms.

5.4.1. k-Nearest Neighbor (k-NN) Algorithm

In the k-nearest neighbor algorithm, the data are classified by calculating the distance by taking into account k number of close neighbors. The most frequently used functions in distance calculation are Euclidean and Manhattan functions (Zhang, 2016). The default distance function of the k-nearest neighbor algorithm in the WEKA application is the Euclidean function.

Our tests for the performance evaluation of the k-nearest neighbor algorithm was carried out by selecting two different values as $k = 1$ and $k = 5$ (1 and 5 close neighbors).

5.4.2. Decision Tree Algorithm

In the decision tree algorithm, the class of the data is determined using the decision tree created from the training data set. While creating the decision tree, the root node is determined first. When determining the root node, the feature that best separates the samples is selected. Then, the structure of the tree is determined by repeating this process in leaf nodes (Aksu & Doğan, 2019).

J48 (C4.5) decision tree algorithm in the WEKA application is used in the our tests for performance evaluation.

5.4.3. Artificial Neural Networks (ANN) Algorithm

Artificial neural networks algorithm has a structure consisting of at least three layers: input layer, middle layer (hidden layer) and exit layer. The intermediate layer can be at least one layer or it can consist of more than one layer. In the artificial neural network, learning is provided by back propagation and the threshold function. The algorithm also includes the momentum coefficient and learning rate variables used in updating the weights (Arı & Berberler, 2017).

For the performance evaluation of the artificial neural networks algorithm, the default values of the chosen multi-layer perceptron algorithm in the WEKA application (hidden layer number 23, sigmoid number 67, momentum 0.2 and learning ratio 0.3) are used.

5.4.4. Logistic Regression Algorithm

The relationship between variables is expressed as a nonlinear "S" shaped curve of the logit model. The curve in question is drawn by calculating the distances of the variables from the curve logarithmically (Ürük, 2007). In our tests, the logit model is used in the calculation of the logistic regression algorithm in the WEKA application.

5.4.5. k-means Clustering Algorithm

In the k-means clustering algorithm, first k objects that form the center of the clusters are selected. Then the distances of other objects to central objects are calculated by using a distance metric like the Euclidean distance function. As a result of the calculation, clusters are formed and the new centers of the formed clusters are determined. This process continues iteratively until the center update process of the clusters ends (Na et al., 2010).

During the implementation of the k-means clustering algorithm in our tests, k = 2 was chosen considering the "Normal" and "Anomaly" network traffic.

5.4.6. Apriori Algorithm

The Apriori algorithm is an association algorithm that works with inductive logic. The algorithm first determines the usage frequency of the data in the data set and makes associations between the most frequently used data. In order for the association rule to be formed, the minimum support and minimum trust criteria must be met (Al-Maolegi & Arkok, 2014). The biggest feature that distinguishes

*Supervised Machine Learning-based Classification of Network Threats/Attacks
Against Computer Systems*

association algorithms from other learning algorithms is that it works successfully with categorical data as well as numerical data.

In our tests, the “KDDTrain” data set was pre-processed by using the feature selection and filtering capabilities of the WEKA application.

6. RESULTS AND EVALUATIONS

The results of our tests are presented by comparing the working time of the algorithms, accuracy and F-measure values.

We first apply the “supplied test set” method of the WEKA application. In the “supplied test set” method, model training is done with the “KDDTrain” data set. The classification performance evaluation of the trained model is carried out with the “KDDTest” data set. We observe that the algorithms classify at a very close accuracy rate with each other as in Table 3. However, the working time of some algorithms is too long when compared to the others. On the other hand, dimension reduction adversely affects the classification performance whereas the processing speed improves with respect to the data with forty-one features.

Table 3. “SuppliedTest Set” method application results evaluation.

Algorithm		Time (s)		Accuracy (%)	
		41 features	6 features	41 features	6 features
k-Nearest Neighbor	1-NN	676,71	410,16	77,09	39,66
	5-NN	677,51	390,13	76,90	41,37
Decision Tree	J48 (C4.5)	37,33	5,97	75,26	45,58
ANN	MLP	10318,14	91,92	75,54	43,08
Regression	Logistic	58,69	4,6	75,61	44,22

In this method, it is seen that the decision tree algorithm has the shortest processing time when both forty-one features and six features are used.

When the k-nearest neighbor algorithms are examined, there is not much difference in terms of time and accuracy. But, when six features used, it is understood that time is shortened. In addition, when six features are used, it has been determined that the multi-layer perceptron algorithm makes classification in a much faster time than forty-one features.

Since the “k-fold cross-validation” method splits the “KDDTrain” data set into “k” folds and use that folds to learn, it makes a very high rate of correct classification. It

is seen that the processing times are longer for both forty-one features and for six features compared to the “supplied test set” method.

However, when the results obtained by using six features are examined, it is seen that the correct classification rates are close to the results obtained by using forty-one features, unlike the “supplied test set” method. When Table 4 is examined, it is seen that the algorithm with the shortest processing time and the highest accuracy data is the decision tree algorithm.

Table 4. “10-fold cross-validation” method application results evaluation.

Algorithm		Time (s)		Accuracy (%)	
		41 features	6 features	41 features	6 features
k-Nearest Neighbor	1-NN	2998,7	2670,38	99,72	99,39
	5-NN	2267,13	1840,23	99,57	99,18
Decision Tree	J48 (C4.5)	457,15	79,02	99,76	99,09
ANN	MLP	82045,11	993,96	99,02	96,39
Regression	Logistic	664,63	47,51	97,50	92,35

It has been determined that the F-measure achieved a high rate of success in the classification of data with "Normal", "DoS" and "Probing" labeled data. When compared the “supplied test set” method (Figure 3 and Figure 6) with the “10-fold cross-validation” method (Figure 4 and Figure 7), it was observed that the F-measure data has lower results in the “supplied test set” method, as in the accuracy data.

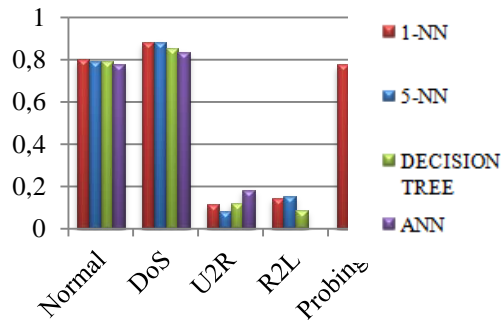

Figure 3. “Supplied Test Set” method F-measure data (41 features).

*Supervised Machine Learning-based Classification of Network Threats/Attacks
Against Computer Systems*

As can be seen in Figure 3, k-NN, Decision Tree and ANN algorithms used in the “supplied test set” method have shown low success in classifying data with "U2R" and "R2L" labeled data. On the other hand, in the “10-fold cross-validation” method (Figure 4), the accuracy rate in the classification of data with "U2R" and "R2L" labeled data is higher, but the rates were not as high as in the data with the other three labeled data.

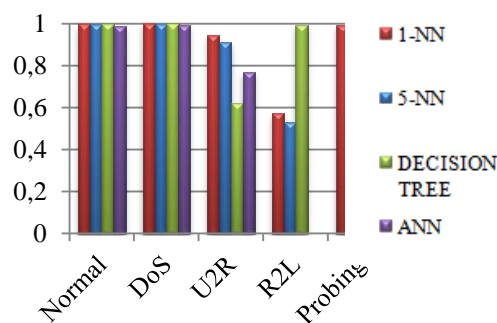

Figure 4. “10-fold cross-validation” method F-measure data (41 Features).

In both figures, it is seen that there is no "R2L" labeled F-measure data for the artificial neural network algorithm. The reason for this is that the classifier cannot classify the data correctly with "R2L" label.

When the F-measure values of the Logistic Regression algorithm were examined (Figure 5), it was observed that the data obtained in the “supplied test set” method was lower than the other supervised learning algorithms, and it was classified at almost the same rates in the “10-fold cross-validation” method.

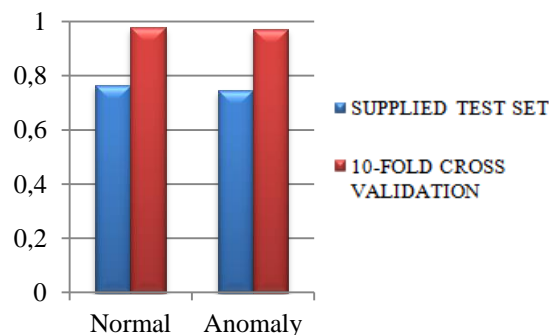

Figure 5. Logistic regression algorithm F-measure data (41 features).

The F-measure data, from the classification using six features obtained as a result of dimension reduction is as in Figure 6, Figure 7 and Figure 8. Algorithms run with “supplied test set” method by using six features showed very low results in F-measure data as well as in accuracy data. When Figure 6 is examined, it is seen that the F-measure data give partial results in the data with "Normal" labeled data.

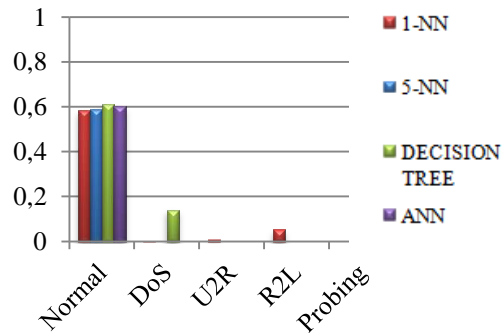

Figure 6. “Supplied Test Set” method F-measure data (6 features).

When Figure 7 is examined, it is seen that the results obtained in the “10-fold cross-validation” method using six features are high, but lower than the results obtained using forty-one features.

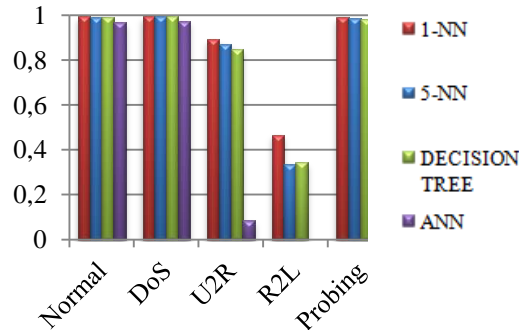

Figure 7. “10-fold cross-validation” method F-measure data (6 features).

*Supervised Machine Learning-based Classification of Network Threats/Attacks
Against Computer Systems*

When the F-measure values of the Logistic Regression algorithm, which is run using six features, are examined (Figure 8), it is seen that the data obtained in the “supplied test set” method is lower than the other supervised learning algorithms, and the classification in the “10-fold cross-validation” method is almost the same. In the Logistic Regression algorithm, which is run using six features, as in other algorithms, it has been found that a lower rate of success is achieved compared to the results obtained by using forty-one features.

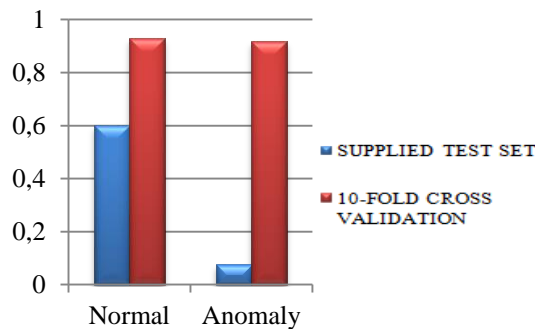

Figure 8. Logistic regression algorithm F-measure data (6 features).

When unsupervised learning algorithms are examined, as a result of the application results of the k-means clustering algorithm using forty-one features, it is seen that it performs a clustering process performed with the “KDDTrain” data set, is 50.3% in 6.05 seconds, and which is run using six features, is 52.1% in 4.99 seconds. Although the k-means clustering algorithm, which is run using forty-one features, provides an advantage in terms of time compared to supervised learning algorithms, it is seen that its accuracy rate is very low. On the other hand, it was determined that the correct classification rate obtained with the k-means clustering algorithm using six features is higher than the correct classification rates obtained in supervised learning algorithms with “supplied test set” method using six features.

The Apriori algorithm, on the other hand, differed from other learning algorithms because it was supported with a feature selection algorithm and subjected to filtering before the application, and it made associations at a reliability level ranging from 70% to 90% in 600.38 seconds. Unlike other algorithms, it can be ensured that the reliability ratio between the data to be correlated is higher in the Apriori algorithm. In other words, the reliability ratio, which is between 70% and

90% in the exemplary application, can be determined to be lower or higher. However, this situation corresponds to more time for a higher reliability rate.

As a result, when the results of all learning algorithms examined within the scope of this study; The fastest working learning algorithm with the lowest classification rate is the clustering algorithm. The Apriori algorithm, which is another unsupervised learning algorithm, can make associations at the desired accuracy rates, but it must be subjected to some pre-processes before this process. When evaluated in terms of time, it has been observed that the process is close to the supervised learning algorithms. It was determined that the 5-Near Neighbor algorithm, one of the supervised learning algorithms, performs better classification in the “supplied test set” method compared to the other algorithms, while the decision tree algorithm performs better in the “10-fold cross-validation method. In general, it has been observed that supervised learning algorithms classify at close accuracy rates, but the algorithms mentioned above are faster than the others in terms of time.

As a result of the classification process performed with the shape of the NSL KDD data set containing forty-one features and six features subjected to the dimensionality reduction process (Principal Component Analysis), it was observed that similar results emerged, and consistent data were obtained considering the applied test methods. It is possible to explain, why the data subjected to the dimensionality reduction process with using “supplied test set” method cannot be classified at desired level, with developing different attack techniques. As a matter of fact, the types of attacks that the learning algorithm “learns” appear in different types day by day. Moreover, the results obtained with the 10-fold cross-validation method are also a positive inference in terms of the saving in time as a result of the dimensionality reduction process.

Apparently, there is a limited amount of data that can be used to compare supervised and unsupervised learning algorithms. Although this situation makes it difficult to choose between algorithms, it is evaluated that the learning algorithm to be used for detecting threats/attacks against network-based computer systems should be preferred among the supervised learning algorithms and pre-processing of the data (Dimensionality reduction, feature selection, etc.) to be used will show high performance in terms of time and correct classification.

7. CONCLUSIONS AND DISCUSSIONS

Today, with the developing technology and increasing internet usage, the security need of computer systems is constantly increasing. It is of great importance to use machine learning in intrusion detection systems developed to meet the increasing security need.

As a matter of fact, attacks on computer systems occur because of the reasons (Zhang et al., 2012):

- Attackers who want unauthorized access to the system;
- Users who are authorized in the system, want to gain additional privileges in matters that they are not authorized, and;
- Misuse of privileges granted to authorized users.

Considering the aforementioned reasons for the attacks, it becomes inevitable to be faced with new types of attacks every day. For this reason, the use of machine learning in intrusion detection systems increases the functionality of attack detection systems and enables new types of attacks to be detected as soon as possible.

Within the scope of this study, the performance evaluation of supervised and unsupervised learning algorithms has been performed by examining intrusion detection systems and machine learning. In order to run supervised and unsupervised learning algorithms, the WEKA application and the NSL KDD data set derived from the KDD CUP-99 data set, which is the most frequently used data set in the literature, were used (Kaya & Yıldız, 2014).

As a result of the measurements carried out, it has been determined that the probability of detecting threats/ attacks against network-based computer systems is higher with supervised learning algorithms. It was observed that the classification rates of the algorithms were close to each other, but the processing times varied, in the two different test methods performed with supervised learning algorithms using the NSL KDD data set.

On the other hand, it has been determined that unsupervised learning algorithms are fast in terms of processing time but have low accuracy rates. Another disadvantage of unsupervised learning algorithms is that they cannot classify. Although they

perform clustering or association process using data, it must be processed once again in order to interpret the outputs of unsupervised learning algorithms.

In the experiments conducted using the NSL KDD data set that was pre-processed (dimensionality reduction), it was observed that the “supplied test set” method had a very low classification rate. In the “10-fold cross-validation” method, it was found that it gave similar results to applications with non-preprocessed data, but the algorithm runtime was shorter.

In future studies to be carried out within the scope of detecting threats/attacks against network-based computer systems, it is necessary to examine a combined algorithm in which unsupervised and supervised learning algorithms can work together, as well as to examine the data that will be input to the algorithms such as dimensionality reduction and/or feature selection. It is considered that the implementation of the aforementioned procedures will be beneficial.

As in the example of the Apriori algorithm, it is evaluated that if the results from the unsupervised learning algorithm are applied as input to the supervised learning algorithm, the results of combined algorithm will yield more positive results than the results of the supervised learning algorithm alone, and the threat/attack can be detected in a shorter time depending on the algorithm selection.

Likewise, it is evaluated that applying pre-processes such as dimensionality reduction and/or feature selection to the data set that will be input to the algorithms can increase performance, shorten the processing time of the algorithms and lead to more precise results.

*Supervised Machine Learning-based Classification of Network Threats/Attacks
Against Computer Systems*

ACKNOWLEDGEMENT

This article is extracted from the Master of Science (M.Sc.) thesis, which is entitled as "Classification of Threats/Attacks Against Network-based Computer Systems with Supervised Machine Learning" at the Barbaros Naval Sciences and Engineering Institute of Türkiye National Defence University in January, 2022.

CONFLICT OF INTEREST STATEMENT

The authors declare no conflict of interest.

REFERENCES

- Aksu, G., & Doğan, N. (2019). "Comparison of decision trees used in data mining". *PegeM Eğitim ve Öğretim Dergisi*, 9(4), 1183-1208. doi:10.14527/pegegog.2019.039.
- Allen, J., Christie, A., Fithen, W., McHugh, J., Pickel, J., & Stoner, E. (2000). *State of the Practice of Intrusion Detection Technologies*. Carnegie Mellon University Technical Report CMU/SEI-99-TR-028.
- Al-Maolegi, M., & Arkok, B. (2014). "An improved apriori algorithm for association rules". *International Journal on Natural Language Computing*, 3(1), 21-29. doi:10.5121/ijnlc.2014.3103.
- Alpaydin, E. (2010). *Introduction to Machine Learning*. The MIT Press.
- Andress, J. (2011). *The Basics of Information Security: Understanding the Fundamentals of Infosec in Theory and Practice*. Syngress.
- Arı, A., & Berberler, M. E. (2017). "Yapay sinir ağları ile tahmin ve sınıflandırma problemlerinin çözümü için arayüz tasarımı". *Acta Infologica*, 1(2), 55-73.
- Avcı, U., & Avcı, M. (2004). "Örgütlerde bilginin önemi ve bilgi yönetimi süreci". *Mevzuat Dergisi*. Vol. 7, No. 74. Retrieved from <http://www.mevzuatdergisi.com/2004/02a/01.htm>
- Bellinger, G., Castro, D., & Mills, A. (2004). "Data, Information, Knowledge & Wisdom". Retrieved from <http://www.systems-thinking.org/dikw/dikw.htm>
- Brownlee, J. (2017). *Master Machine Learning Algorithms: Discover How They Work and Implement Them From Scratch*. Machine Learning Mastery.
- Brynjolfsson, E., & Mitchell, T. (2017). "What can machine learning do? Workforce implications". *Science*, 358(6370), 1530-1534. doi:10.1126/science.aap8062.

*Supervised Machine Learning-based Classification of Network Threats/Attacks
Against Computer Systems*

Chae, H., Jo, B., Choi, S., & Park, T. (2013). "Feature selection for intrusion detection using NSL-KDD". *Recent Advances in Computer Science*, 184-187.

Deshmukh, D. H., Ghorpade, T., & Padiya, P. (2015). "Improving classification using preprocessing and machine learning algorithms on NSL-KDD dataset". *2015 International Conference on Communication, Information & Computing Technology (ICCICT)*, 1-6. doi:10.1109/iccict.2015.7045674.

Dhanabal, L., & Shantharajah, S. P. (2015). "A study on NSL-KDD dataset for intrusion detection system based on classification algorithms". *International Journal of Advanced Research in Computer and Communication Engineering*, 4(6), 446-452.

Ersoy, E. V. (2012). *ISO/IEC 27001 Bilgi Güvenliđi Standardı*. ODTÜ Geliřtirme Vakfı Yayıncılık ve İletişim.

Ferrag, M. A., Maglaras, L., Moschoyiannis, S., & Janicke, H. (2020). "Deep learning for cyber security intrusion detection: Approaches, datasets, and comparative study". *Journal of Information Security and Applications*, 50, 102419. doi:10.1016/j.jisa.2019.102419.

İlter, H. K. (2011). "Bilgeliđe giden yol mideden geđer mi?" *PiVOLKA*, 20(6), 3-7.

Karataş, G., Demir, O., & Şahingöz, O. K. (2018). "Deep learning in intrusion detection systems". *2018 International Congress on Big Data, Deep Learning and Fighting Cyber Terrorism (IBIGDELFT)*. doi:10.1109/ibigdelft.2018.8625278.

Kaya, Ç. (2016). *Saldırı tespit sistemlerinde makine öğrenmesi tekniklerinin kullanılması: Karşılaştırmalı performans analizi* (Master's Thesis). Gazi Üniversitesi, Fen Bilimleri Enstitüsü, Ankara.

Kaya, Ç., & Yıldız, O. (2014). "Makine öğrenmesi teknikleriyle saldırı tespiti: Karşılaştırmalı analiz". *Marmara University Journal of Science*, 26(3), 108. doi:10.7240/mufbed.24684.

Kocabıyık, L. (2005). *Information and knowledge management in the military domain* (Master's Thesis). Vrije Universiteit Brussel, Faculty of Economic, Social and Political Sciences, Brussels.

Kohavi, R. (1995). "A study of cross-validation and bootstrap for accuracy estimation and model selection". *International Joint Conference on Artificial Intelligence*, 14(12), 1137-1143.

Kramer, S., & Bradfield, J. C. (2009). "A general definition of malware". *Journal in Computer Virology*, 6(2), 105-114. doi:10.1007/s11416-009-0137-1.

Kurgun, O. A. (2006). "Bilgi yönetim sistemlerinin yapılandırılması". *Dokuz Eylül Üniversitesi Sosyal Bilimler Enstitüsü Dergisi*, 8(1), 274-291.

Liu, G. G. (2014). "Intrusion detection systems". *Applied Mechanics and Materials*, 596, 852-855. doi:10.4028/www.scientific.net/amm.596.852.

Na, S., Xumin, L., & Yong, G. (2010). "Research on k-means clustering algorithm: An improved k-means clustering algorithm". *2010 Third International Symposium on Intelligent Information Technology and Security Informatics*, 63-67. doi:10.1109/iitsi.2010.74.

Nguyen, T. T., & Armitage, G. (2008). "A survey of techniques for internet traffic classification using machine learning". *IEEE Communications Surveys & Tutorials*, 10(4), 56-76. doi:10.1109/surv.2008.080406.

Önaçan, M. B. K. (2015). *Organizasyonlar için bilgi yönetimi çerçevesi ve bilgi yönetim sistemi mimarisi önerisi: Doblyn (Doküman ve bilgi yönetimi)* (Ph.D. Thesis). Ankara Üniversitesi, Sosyal Bilimler Enstitüsü, Ankara.

Simeone, O. (2018). "A brief introduction to machine learning for engineers". *Foundations and Trends in Signal Processing*, 12(3-4), 200-431. doi:10.1561/20000000102.

Solomon, M. G., & Chapple, M. (2005). *Information Security Illuminated*. Jones and Bartlett.

*Supervised Machine Learning-based Classification of Network Threats/Attacks
Against Computer Systems*

Taher, K. A., Jisan, B. M. Y., & Rahman M. M. (2019). "Network intrusion detection using supervised machine learning technique with feature selection". International Conference on Robotics, Electrical and Signal Processing Techniques (ICREST), 643-646. doi:10.1109/ICREST.2019.8644161.

Thomas, R., & Pavithran, D. (2018). "A survey of intrusion detection models based on NSL-KDD data set". *2018 Fifth HCT Information Technology Trends (ITT)*, 286-291. doi:10.1109/ctit.2018.8649498.

Ürük, E. (2007). *İstatistiksel uygulamalarda lojistik regresyon analizi* (Master's Thesis). Marmara Üniversitesi, Fen Bilimleri Enstitüsü, İstanbul.

Witten, I. H., Hall, M., Frank, E., Holmes, G., Pfahringer, B., & Reutemann, P. (2009). "The WEKA data mining software". *ACM SIGKDD Explorations Newsletter*, 11(1), 10-18. doi:10.1145/1656274.1656278.

Yiğidim, H. A. (2012). *Makine öğrenme algoritmalarını kullanarak ağ trafiğinin sınıflandırılması* (Master's Thesis). TOBB Ekonomi ve Teknoloji Üniversitesi, Fen Bilimleri Enstitüsü, Ankara.

Yost, J. R. (2016). "The march of IDES: Early history of Intrusion-Detection expert systems". *IEEE Annals of the History of Computing*, 38(4), 42-54. doi:10.1109/mahc.2015.41.

Zhang, Z. (2016). "Introduction to machine learning: K-nearest neighbors". *Annals of Translational Medicine*, 4(11), 218. doi:10.21037/atm.2016.03.37.

Zhang, X., Jia, L., Shi, H., Tang, Z., & Wang, X. (2012). "The application of machine learning methods to intrusion detection". *2012 Spring Congress on Engineering and Technology*, 1-4. doi:10.1109/scet.2012.6341943.

RESEARCH ARTICLE

**An ethical committee approval and/or legal/special permission has not been required within the scope of this study.*

SINGLE PHASE MEASUREMENT IN UME KIBBLE BALANCE – 3*

Beste KORUTLU¹

¹*TÜBİTAK National Metrology Institute (UME), Kocaeli,
Turkey,
beste.korutlu@tubitak.gov.tr; ORCID: 0000-0003-3746-6317*

Received: 30.12.2021

Accepted: 11.02.2022

ABSTRACT

Kibble Balance developed in National Metrology Institute of Turkey allows the new definition of kilogram to be realized in single phase where the Faraday's Law of Induction and Lorentz Law of Force are tested simultaneously thanks to its design with moving magnet. Although there are numerous advantages of this design, like being less sensitive to environmental and experimental conditions, there appear the problem of distinguishing the voltage induced across the ends of the coil as a result of Faraday's Law of Induction and the voltage due to the current delivered to coil to generate the Lorentz Force, with a relative uncertainty of some parts of a billion. In order to get the best possible performance of the digital multimeter measuring the voltage of the coil, a waveform generator is connected in series to the multimeter as a compensating voltage source so that the voltage due to the supplied current is almost eliminated in the input of the multimeter. However, temporal voltage fluctuations in the waveform generator may induce additional voltage at the coil. In this paper, we show that these random effects are eliminated with an uncertainty of 15 ppb in case the experiment lasts for at least 48 hours.

Keywords: *Kilogram, Planck Constant, Kibble Balance, Single Phase Measurement.*

UME KİBBLE BALANS – 3 İLE TEK FAZDA ÖLÇÜM

ÖZ

Türkiye Ulusal Metroloji Enstitüsü'nde geliştirilen Kibble Balance, hareketli mıknatıslı tasarımı sayesinde, yeni kilogram tanımında Faraday İndüksiyon Yasası ve Lorentz Kuvvet Yasasının aynı anda test edildiği tek fazda ölçüme olanak tanıyor. Bu tasarımda, çevresel ve deneysel koşullara daha az duyarlı olması gibi sayısız avantaj olmasına rağmen, Faraday İndüksiyon Yasasının bir sonucu olarak bobinin uçlarında indüklenen voltaj ile akımdan kaynaklanan voltajı milyarda birkaç bağıl belirsizlikle ayırt etme sorunu ortaya çıkmaktadır. Bobin voltajını ölçen dijital multimetreden mümkün olan en iyi performansı elde etmek için, kompanzasyon voltaj kaynağı olarak multimetreye seri olarak bir dalga formu üretici bağlanır, böylece akımdan kaynaklanan voltaj, multimetrenin girişinde neredeyse ortadan kalkar. Fakat, dalga formu üreticinde zamana bağlı voltaj dalgalanmaları, bobinde ek voltajı indükleyebilir. Bu yazıda, deneyin en az 48 saat sürmesi durumunda bu rastgele etkilerin 15 ppb belirsizlikle elimine edildiğini gösteriyoruz.

Anahtar Kelimeler: *Kilogram, Planck Sabiti, Kibble Balans, Tek Fazda Ölçüm.*

1. INTRODUCTION

The advances in science and technology and the measurement accuracy are closely interconnected with each other such that a major progress in one eventually culminates with a breakthrough in the other. The measurement accuracy of a physical quantity is restricted by the agreed definitions of the relevant units. In order to minimize these restrictions, after decades of pioneering scientific work, the International System of Units (SI) underwent a substantial modification in the definitions of four of the seven base units: the kilogram, the Kelvin, the ampere and the mole (Stock, Davis, de Mirandés, & Milton, 2019). The most substantial revision was in the definition of SI mass unit, the kilogram (Richard, Fang, & Davis, 2016). Prior to the revision, kilogram was the last SI base unit to be defined in terms of a material artefact, the International Prototype of Kilogram (IPK). It has been kept in the International Bureau of Weights and Measures (BIPM) since the agreement of the IPK to be the basis for the unit of mass in 1889. The accuracy of mass or mass related measurements in this artefact-based definition was constrained by the irreversible contamination or mechanical wear on the IPK. As the mass of IPK was assumed exactly to be equal to one kilogram with zero error and zero uncertainty, the validation of such possible alterations in the IPK mass was unfeasible. In addition, the traceability to the kilogram was ultimately only available from the BIPM since IPK, since it was under the authority of the BIPM. The long-awaited ambition for there to be a uniform, long term stable and worldwide accessible unit of mass, lead to the redefinition of kilogram in terms of the fixed value of Planck constant, a fundamental constant of nature. It took nearly 130 years for this dream to come true as future technologies were needed to realize it with sufficient accuracy. The new definition of the kilogram, adopted since 20 May 2019, does not recommend a technique for the practical realization of the unit in terms of Planck constant, thus allowing to take advantage of future developments without the need to redefine it once again. Currently, there are two methods with the capability of realizing the new kilogram at the required total relative uncertainty of 2×10^{-8} : The Kibble Balance (KB) experiment (Robinson, & Kibble, 2007; Kibble, & Robinson, 2014; Wood et al., 2017; Fang et al., 2020; Kim et al., 2020; Baumann et al., 2013; Haddad et al., 2017; Thomas et al., 2017;

Li et al., 2020; Sutton, 2009; Ahmedov et al. 2018; Marangoni et al., 2019) and the X-Ray Crystal Density (XRCD) experiment (Fujii et al., 2016; Kuramoto et al., 2017; Bartl et al., 2017). Moreover, within the revised SI, as opposed to the previous situation, the traceability of the kilogram can be provided by any National Metrology Institute (NMI) operating a primary realization method.

Kibble Balance experiments have been constructed in the NMIs from different parts of the world in different geometries and with different experimental protocols. This is a favorable situation for better understanding of the possible systematic errors. The link between the kilogram and Planck constant in KBs is achieved by the comparison of the mechanical power with the electrical one. The main components of the KB experiments are a magnet and a coil. The power comparison is achieved in two concurrent or simultaneous phases depending on the operation protocol of the system. National Metrology Institute of Turkey (UME), operating under the umbrella of the Scientific and Technological Research Council of Turkey (TÜBİTAK), contributes to the ongoing worldwide research with a Moving-Magnet Kibble Balance Experiment as opposed to the traditional approach with a moving coil. Single phase measurement scheme is one of the most important outcomes of this configuration where the Faraday's Law of Induction and Lorentz Law of Force are tested simultaneously. Apart from many distinctive advantages, there is one difficulty to be tackled in simultaneous scheme such that the total voltage across the ends of the coil pair should be decomposed with relative uncertainties of about some part of a billion as the induced Faraday's voltage across the ends of the coil due to the motion of the magnet with respect to the coil (Faraday's Law of Induction) and the voltage due to the supplied current to the coil (Lorentz Law of Force). As the performance of the digital multimeter used in voltage measurements gets better at 1 V range, a compensating voltage is generated by a waveform generator connected in series to multimeter so that the input voltage of the multimeter is almost solely the Faraday's voltage. However, due to the temporal voltage fluctuations in the waveform generator, an additional voltage is induced on the coil. In this paper, we show that it is possible to distinguish the induced voltage due to the motion of the magnet assembly and the voltage due to the electric current across the ends of the

coil with uncertainties of parts per billion despite the noise generated by the waveform generator in case the duration of the experiment lasts at least 48 hours.

In the following section, the KB principle is explained. The UME KB-3 is introduced in Section 3. In Section 4, the electrical measurement procedure in UME KB-3 is explained in details and supported with experimental results. The last section is reserved for conclusion.

2. KIBBLE BALANCE PRINCIPLE

The Kibble Balance principle links the macroscopic mass m of an artefact with the Planck constant h of the quantum world by comparing the mechanical power with the electrical one. Initially, it was called as Watt Balance. It is replaced with Kibble Balance after the inventor of the idea, Dr. Brian Kibble passed away in 2016. The comparison is achieved in two concurrent or simultaneous phases (the moving and the weighing phases) depending on the operation protocol of the system. In the moving phase, the underlying principle is the Faraday's Law of Induction where the relative motion with a velocity v between a coil of length L and a surrounding magnet having a radial magnetic flux density of B induces a voltage V across the ends of the coil such that $V = BLv$. In the weighing phase, the gravitational force acting on the mass artefact is counter balanced by the Lorentz Force generated on the coil carrying a current I in the magnetic field yielding $mg = BLI$ where g is the gravitational acceleration. The common factor BL appearing in both phases of the experiment cannot be measured with high accuracy. In the ideal case of the velocity and Lorentz Force being in the direction of the gravitational acceleration, the combined equations give rise to the Kibble Balance principle

$$mgv = VI, \tag{1}$$

where left-hand side is the mechanical power while the right-hand side is the electrical one. The common factor disappears under the assumption of its steadiness in two phases. Although the Planck constant does not appear explicitly in Eq. (1), it comes into play as the electrical quantities are measured by using Josephson Voltage Standard and Quantum Hall Standard.

Single Phase Measurement in UME Kibble Balance - 3

The time integral for of the Kibble Balance equation is known as the Joule balance principle.

$$mgZ = \Phi I, \quad (2)$$

where Φ is the magnetic flux in the coil induced due to motion of the magnet assembly with respect to the coil and Z is the displacement of the coil. In UME KB-3 the Joule Balance principle is used.

3. THE UME KB-3

The originally devised KB experiment at the National Physical Laboratory (NPL) by Brian Kibble relates the mechanical and the electrical powers by means of a stationary magnet assembly and moving coil within the air gap of that magnet assembly. The majority of the KBs developed in the NMIs for realizing the new definition of kilogram followed in the footsteps of this initial design. UME, on the other hand, has shifted this ground by a design with a moving magnet assembly and stationary coil residing in the air gap. On account of this construction, the simultaneous operation of moving and weighing phases becomes possible. The notable outcome of single phase measurement is that it relaxes the need for monitoring the environmental and experimental conditions with a relative uncertainty at the order of parts per billion. The moving magnet design leads to additional significant advantages like using a local vacuum for displacement measurements rather than a global one and performing mass measurements in ambient air conditions instead of under vacuum. The displacement measurements, carried by laser interferometers, oblige the refractive index to be stable along the paths of the laser beams in order to reach the required uncertainties by the kilogram realization experiments. In moving coil experiments, as the coil cannot be decoupled from the rest of the set-up, a global vacuum covering the entire system is the only option to ensure this requirement. The moving magnet design, on the other hand, allows the use of a local vacuum in the vicinity of the magnet assembly (Ahmedov et al., 2020). As a result, the set-up become more economical since the rest of the system does not have to be vacuum compatible. The ambient air mass measurement is favorable for further disseminating the kilogram which takes place entirely in air. Consequently, a vacuum/air transfer mechanism

for the mass artifact is not necessary and the possible sorption effects due to such transfer are avoided (Davidson, 2010).

The design of the UME KB-3 apparatus is given in Figure 1.

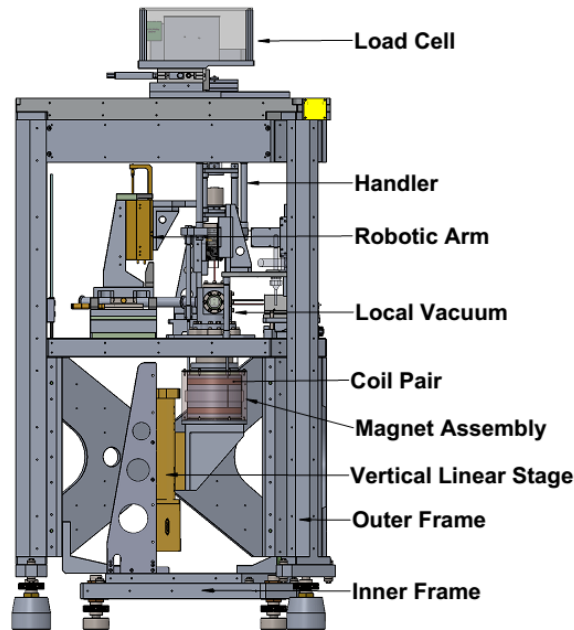

Figure 1. The solid drawing of UME KB-3 apparatus.

It is constructed on two mechanically decoupled rigid support frames. The moving magnet assembly is placed on the inner support frame while the stationary coil pair is hanging from the outer support frame. In this way, the mechanical vibrations due to the magnet motion on the inner frame are not reflected on outer frame where the force and displacement measuring systems are mounted. The vertical motion of the magnet assembly is delivered by the vertical linear stage fixed on the inner support frame. The reversely wound coil pair is used instead of a single coil in order to minimize the effect of Earth magnetic field on the system (Ahmedov et al., 2020). The robotic arm places the mass artifact on the handler and takes it off from the handler. The load cell measures the difference between the

gravitational force on the mass artifact and balancing Lorentz Force generated on the coil pair.

4. ELECTRICAL MEASUREMENTS

The magnet assembly undergoes a triangular like motion with respect to the coil pair along the direction of gravitational acceleration at a period of 1 s. The vertical displacement of the magnet for 10 s is illustrated in Figure 2.

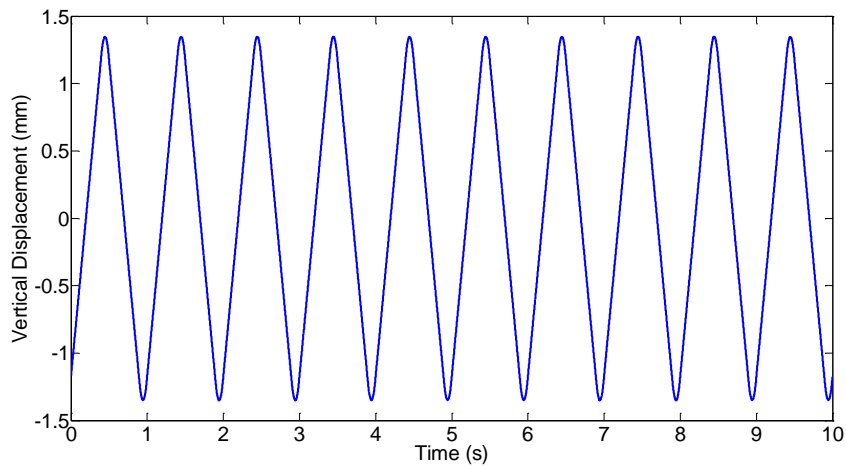

Figure 2. The vertical motion of the magnet for 10 s.

As a result of the magnet motion, a triangular shaped flux is generated through the coil pair. In other words, the square shaped Faraday's voltage, proportional to the time derivative of the flux with a minus sign, is induced across the ends of the coil pair. As the moving and weighing phases of the experiment are performed at once, in addition to the Faraday's voltage, there is also the voltage due to the electric current delivered to the coil pair by the current source. Therefore, the output voltage of the coil pair is the sum of Faraday's voltage and the voltage due to the supplied electrical current and it needs to be decomposed as its clear from Eq. (2). The resistance of the coil pair is 166Ω and the supplied current is 38.4 mA yielding an electrical voltage on the coil pair of around 6.4 V. The voltage data across the ends of the coil pair is collected with Keysight 3458A Digital Multimeter with a

sampling frequency of 2 Hz. The high voltage due to the supplied current to the coil pair forces the measuring device to work at 10 V range with a resolution of 100 nV. It provides a resolution 10 nV at 1 V range. In order to switch to 1 V range, a Keysight 33512B waveform generator is connected in series to the multimeter across the coil pair as a compensating voltage source. In Figure 3, the circuit diagram of the electrical measurements is given. WG stands for the waveform generator. A standard resistor R is connected in series to the coil pair for the determination of the electrical current supplied to the coil pair with better uncertainty. The Guildline 7330 standard resistor of 25Ω is kept in the 7108-256 Fluke Resistor Bath with temperature stability 10 mK. The temperature coefficient of the standard resistor is low enough $(-3.22 \times 10^{-8} \pm 2.1 \times 10^{-9})/K$ to satisfy the desired total relative uncertainty by the realization experiment.

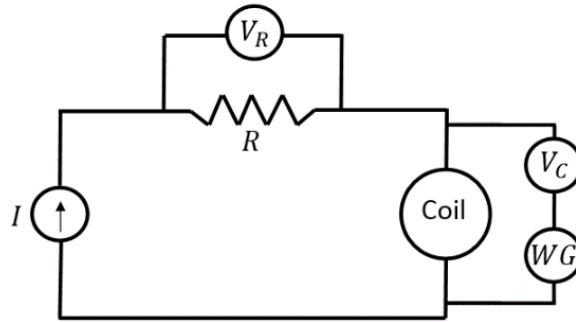

Figure 3. The output voltage of the coil pair.

In Figure 4, the output voltage of the coil pair is given for 10 s for illustration purposes where the electrical voltage is compensated by the waveform generator. As the amplitude is lower than 1 V, the multimeter operates at 1 V range. However, due to the temporal variations of the compensating voltage by the waveform generator, an additional voltage may be induced on the coil pair. Therefore, it is critical to check whether the current induced voltage could be decoupled from the Faraday's voltage and the random contribution due to the waveform generator is eliminated in long-term measurements or not. In order to do so, the magnet assembly is kept at rest (Faraday's voltage is not induced on the coil pair) while the

Single Phase Measurement in UME Kibble Balance - 3

electrical current is delivered to the coil pair by the current source. The compensating voltage is generated by the waveform generator connected in series to the multimeter.

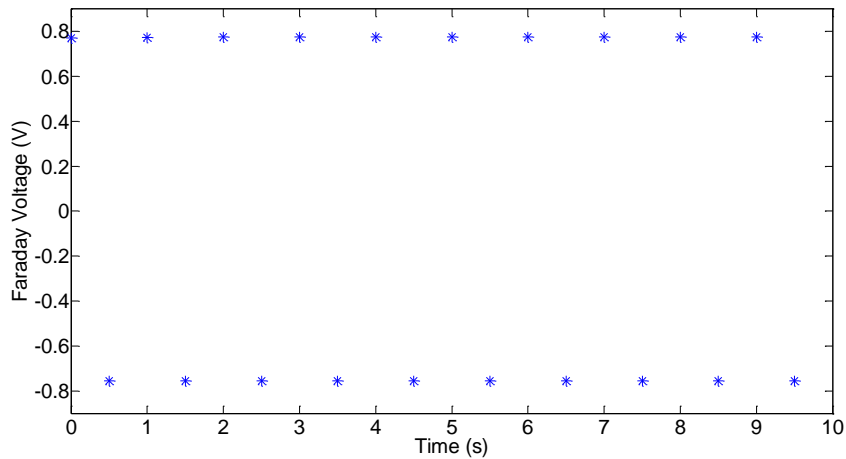

Figure 4. The output voltage of the coil pair. The sampling frequency of the multimeter is set to 2 Hz. The integration time of the device is set to 450 ms.

In Figure 5 the average value of the normalized electrical current effect as a function of time is given in blue stars. The normalization is done with respect to the total flux. The red dashed line indicates the expected zero contribution. In Figure 6, the standard uncertainty of the normalized electrical current with respect to time is given in blue stars. The red dashed line at 20 ppb stands for the highest total relative uncertainty anticipated by the realization experiments. It is clear that the mean value converges to zero within the uncertainty of 15 ppb for 48 hours or more. It has been observed that the major contribution in this measurement comes from the fluctuation in the current source rather than the induced voltage by the temporal variations of the waveform generator. This test is performed by applying solely the compensating voltage on the coil pair by the waveform generator when the output current by the current source is set to zero. The effect due to the waveform generator converges to zero within 5 ppb relative uncertainty about 10 hours. In conclusion, using a waveform generator is a

practical solution in the realization experiment with a KB for having a better performance with the digital multimeter.

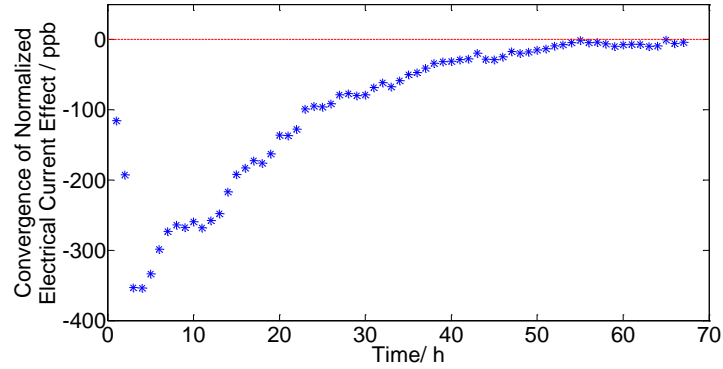

Figure 5. The average value of the normalized electrical current effect with respect to is given in blue stars. The normalization is done with respect to the total flux of the coil. The red dashed line indicates the expected zero contribution.

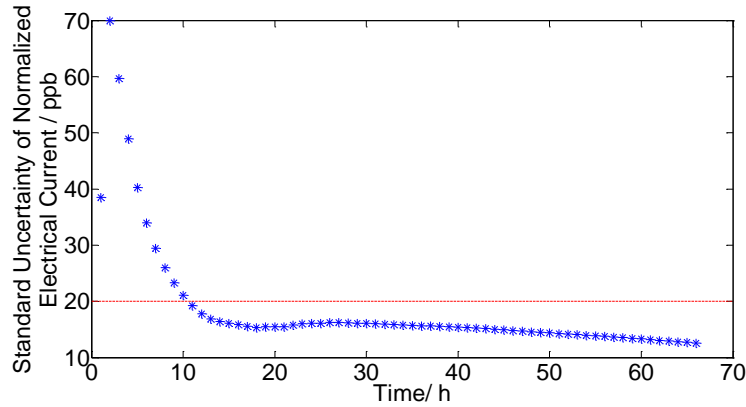

Figure 6. The standard uncertainty of the normalized electrical current effect with respect to time is given in blue stars. The normalization is done with respect to the total flux of the coil. The red dashed line at 20 ppb stands for the highest total relative uncertainty anticipated by the realization experiments.

5. CONCLUSION

Kibble Balance experiments allows the realization of mass unit in terms of Planck constant by the comparison of the mechanical power with the electrical one in accordance with the new definition of the kilogram. TÜBİTAK UME followed a different path in providing this link such that the UME KB-3 is constructed with a moving magnet as opposed to the traditional ones with a moving coil with the motivation to perform the measurement in one single phase. Despite many distinctive advantages of the simultaneous testing of Faraday's Law of Induction and Lorentz Force Law, there is one difficulty to be handled. The total voltage across the ends of the coil pair should be decomposed with relative uncertainties of about some part of a billion. The current induced voltage has an amplitude of 6.4 V. The digital multimeter measuring the voltage of the coil has a better performance at lower ranges. This is why; a waveform generator is connected in series to the multimeter as a compensating voltage source. However, one has to be careful since the temporal variations of the waveform generator may induce additional voltage on the coil pair. We have observed that this effect converges to zero for 10 hours within 5 ppb relative uncertainty. Therefore, the waveform generator is a practical solution for having better performance with the multimeter. However, fluctuations due to the current source require at least 48 hours measurement time for 15 ppb uncertainty. This uncertainty could be further reduced by decreasing the resistance of the coil pair or replacing the current source with a more stable one.

Beste KORUTLU

ACKNOWLEDGEMENTS

This research is funded by the TÜBİTAK National Metrology Institute of Turkey with project number G2ED-E1-03-I.

The author sincerely thanks to Dr. Hacı Ahmedov and Recep Orhan for fruitful discussions.

CONFLICT OF INTEREST STATEMENT

The author declares no conflict of interest.

REFERENCES

Ahmedov, H., Babayiğit Aşkın, N., Korutlu, B., & Orhan, R. (2018). “Preliminary Planck constant measurements via UME oscillating magnet Kibble balance”. *Metrologia*, Vol. 53, 86–97.

Ahmedov, H., Celik M., Orhan, R., Korutlu, B., Hamid, R., & Sahin, E. (2020). “A UME Kibble Balance Displacement Measurement Procedure”. *Acta IMEKO*, Vol. 9:3, 11-16.

Ahmedov, H., Korutlu, B., Dorosinskiy, L., & Orhan, R. (2020). “External Magnetic Field Measurements in the UME Kibble Balance”. *Acta IMEKO*, Vol. 9:3, 33-39.

Bartl, G., Becker, P., Beckhoff, B., Bettin, H., Beyer, E., Borys, M., Busch, I., Cibik, L., D'Agostino, G., Darlatt, Di Luzio, E. M., Fujii, K., Fujimoto, H., Fujita, K., Kolbe, M., Krumrey, M., Kuramoto, N., Massa, E., Mecke, M., Mizushima, S., Müller, M., Narukawa, T., Nicolaus, A., Pramann, A., Rauch, D., Rienitz, O., Sasso, C. P., Stopic, A., Stosch, R., Waseda, A., Wundrack, S., Zhang, L., & Zhang, X. W. (2017). “A new ²⁸Si single crystal: counting the atoms for the new kilogram definition”. *Metrologia*, Vol. 54, 693-715.

Baumann, H., Eichenberger, A., Cosandier, F., Jeckelmann, B., Clavel, R., Reber, D., & Tommasini, D. (2013). “Design of the new METAS watt balance experiment Mark II”. *Metrologia*, Vol. 50, 235–242.

Davidson, S. (2010). “Determination of the effect of transfer between vacuum and air on mass standards of platinum–iridium and stainless steel”. *Metrologia*, Vol. 47 487-497.

Fang, H., Bielsa, F., Li, S., Kiss, A., & Stock, M. (2020). “The BIPM Kibble balance for realizing the kilogram definition”. *Metrologia*, Vol. 57, 045009, 1-10.

Beste KORUTLU

Fujii, K., Bettin, H., Becker, P., Massa, E., Rienitz, O., Pramann, A., Nicolaus, A., Kuramoto, N., Busch, I., & Borys, M. (2016). "Realization of the kilogram by the XRCD method". *Metrologia*, Vol. 53, A19–A45.

Haddad, D., Seifert, F., Chao, L. S., Possolo, A., Newell, D. B., Pratt, J. R., Williams, C. J., & Schlamminger, S. (2017). "Measurement of the Planck constant at the National Institute of Standards and Technology from 2015 to 2017". *Metrologia*, Vol. 54, 633-641.

Kibble, B. P., & Robinson, I. A. (2014). "Principles of a new generation of simplified and accurate watt balances". *Metrologia*, Vol. 51, 132–139.

Kim, D., Kim, M., Seo, M., Woo, B.-C., Lee, S., Kim, J.-A., Chae, D.-H., Kim, M.-S., Choi, I.-M., & Lee, K.-C. (2020). "Realization of the kilogram using the KRISS Kibble balance". *Metrologia*, Vol. 57, 055006 1-16.

Kuramoto, N., Mizushima, S., Zhang, L., Fujita, K., Azuma, Y., Kurokawa, A., Okubo, S., Inaba, H., & Fujii, K. (2017). "Determination of the Avogadro constant by the XRCD method using a ²⁸Si-enriched sphere". *Metrologia*, Vol. 54, 716-729.

Li, Z., Bai, Y., Xu, J., You, Q., Wang, D., Zhang, Z., Lu, Y., Hu, P., Liu, Y., He, Q., & Tan, J. (2020). "The upgrade of NIM-2 joule balance since 2017". *Metrologia*, Vol. 57, 055007, 1-15.

Marangoni, R. R., Haddad, D., Seifert, F., Chao, L. S., Newell, D. B., & Schlamminger, S. (2019). "Magnet system for the Quantum Electro-Mechanical Metrology Suite" *IEEE Transactions on Instrumentation and Measurement*, Vol. 69, 5736-5744.

Richard, P., Fang, H., & Davis, R. (2016). "Foundation for the redefinition of the kilogram". *Metrologia*, Vol. 53, A6–A11.

Robinson, I. A., & Kibble, B. P. (2007). "An initial measurement of Planck's constant using the NPL Mark II watt balance". *Metrologia*, Vol. 44, 427–440.

Single Phase Measurement in UME Kibble Balance - 3

Stock, M., Davis, R., de Mirandés, E., & Milton, M. J. T. (2019). “Corrigendum: The revision of the SI—the result of three decades of progress in metrology”. *Metrologia*, Vol. 56, 022001, 1-14.

Sutton, C. M. (2009). “An oscillatory dynamic mode for a watt balance”. *Metrologia*, Vol. 46, 467–72.

Thomas, M., Ziane, D., Pinot, P., Karcher, R., Imanaliev, A., Pereira Dos Santos, F., Merlet, S., Piquemal, F. & Espel, P. (2017). “A determination of the Planck constant using the LNE Kibble balance in air”. *Metrologia*, Vol. 54, 468–480.

Wood, B. M., Sanchez, C. A., Green, R. G., & Liard, J. O. (2017). “A summary of the Planck constant determinations using the NRC Kibble balance”. *Metrologia*, Vol. 54, 399-409.

RESEARCH ARTICLE

**An ethical committee approval and/or legal/special permission has not been required within the scope of this study.*

**RADIATIVE CORRECTIONS TO NEUTRINO MASS IN TYPE-3/2
SEESAW MECHANISM***

Canan Nurhan KARAHAN¹

¹*National Defence University, Turkish Naval Academy, Department
of Basic Sciences, Istanbul, Turkey,
ckarahan@dho.edu.tr; ORCID: 0000-0003-1218-0451*

Received: 15.02.2022

Accepted: 02.03.2022

ABSTRACT

Recently proposed Type-3/2 seesaw mechanism is an alternative model to the Type-I seesaw. In this novel mechanism the light neutrino masses are induced via a vector-spinor, which keeps the Higgs mass stabilized at one loop. Here, in this letter, radiative corrections to the light neutrino masses via this vector spinor are studied. It is shown that the active neutrinos get trivial correction from the vector spinor loop as long as the mass of vector spinor is at the order of 2.8×10^{12} GeV or higher. This is in agreement with the minimum mass value required for inducing active neutrino masses ($M_\psi \approx 10^{14}$ GeV) and naturalness criteria of Higgs field ($M_\psi \approx 10^{16}$ GeV) in Type-3/2 seesaw mechanism.

Keywords: *Neutrino Mass, Type-3/2 Seesaw Mechanism, Radiative Corrections.*

TİP-3/2 TAHTAREVALLİ MEKANİZMASINDA NÖTRİNO KÜTLESİNE GELEN IŞINIMSAL DÜZELTMELER

ÖZ

Yakın zamanda önerilen Tip-3/2 tahtarevalli mekanizması, Tip-I tahtarevalliye alternatif bir modeldir. Bu yeni mekanizmada, hafif nötrino kütleleri, Higgs kütlelerini bir döngüde sabit tutan bir vektör-spinör aracılığıyla indüklenir. Burada, bu makalede, bu vektör spinör aracılığıyla hafif nötrino kütlelerine yapılan ışınımsal düzeltmeler incelenmiştir. Vektör spinör kütlesi 2.8×10^{12} GeV veya daha yüksek olduğu sürece, aktif nötrinoların vektör spinör döngüsünden önemsiz düzeltmeler aldığı gösterilmiştir. Bu, Tip-3/2 tahtarevalli mekanizmasında aktif nötrino kütlelerini indüklemek için gereken minimum kütle değeri ($M_\psi \approx 10^{14}$ GeV) ve Higgs alanının doğallık kriteri ($M_\psi \approx 10^{16}$ GeV) ile uyumludur.

Anahtar Kelimeler: *Nötrino Kütlesi, Tip-3/2 Tahtarevalli Mekanizması, Işınımsal Düzeltmeler.*

1. INTRODUCTION

One of the outstanding shortcomings of the Standard Model (SM) is small but nonzero neutrino masses. SM predicts that neutrinos have no mass, which is in contradiction with results from experiments detecting neutrinos from the Sun (Simirnov, 2003) as well as atmospheric neutrinos produced by cosmic rays (Y. Fukuda et al. [Super-Kamiokande], 1998). This conflict between the theory and experiments shows that SM needs to be extended with at least a new physics (NP) field.

Neutrino physics has come of age in the past two decades (Balantekin and Kayser, 2018). However, the nature of neutrino mass is still an open question. Neutrinos may be Dirac ($\nu \neq \bar{\nu}$) or Majorana ($\nu = \bar{\nu}$) particles. Although, there are many Dirac mass models in which lepton number conservation is imposed without a satisfactory reason (Demir et al., 2008; Bonilla and Valle, 2016; Wang and Han, 2017; Yao and Ding., 2018; Calle et al., 2019; Saad, 2019; Jana et al., 2019), due to the fact that the constructions are more simpler and economical, Majorana-type neutrinos which violate lepton number seem to be the more promising case. In literature, there is a vast number of attempts to explain light neutrino masses via new physics beyond the SM. The first and foremost among them is the seesaw mechanism (Gell-Mann et al., 1979) introducing the Majorana-type particles as right handed neutrinos of heavy masses at GUT scale, which generate the light neutrino masses at tree-level from a dimension-5 operator: the Weinberg operator. In this mechanism, the mediator of Weinberg operator is a singlet fermion and this is the first attempt (Type-I seesaw mechanism) to obtain the suppressed neutrino masses via a new physics scale with a factor v_H/Λ_{NP} . There are also Type-II seesaw (Cheng and Li, 1980; Schechter and Valle, 1980) (Mediator: A triplet scalar) and Type-III seesaw (Foot et al., 1989) (Mediator: A triplet fermion) mechanisms in literature. Apart from the seesaw mechanisms at tree level, there are also radiative neutrino mass models (Hou and Wong, 1994; Nomura et al., 2021; Ma and Suematsu, 2009; Babu and Julio, 2012; Hehn and Ibarra, 2013; Nomura et al., 2017; Ahriche et al., 2018), which produce neutrino masses at loop levels (for the most recent reviews see (Cai et al., 2017; Klein et al., 2019)). Despite numerous neutrino mass models (Herrero-García and Schmidt, 2019), the non-observation of right handed neutrinos, Higgs

triplets of $SU(2)_l$ and the glitches associated with the non-renormalizable terms, which are part of some of these models show the necessity to continue the studies on BSM.

Recently, a completely new approach to the neutrino mass problem has been put forward and dubbed the Type-3/2 seesaw mechanism, in which the SM is extended with vector-spinor fields (Demir et al., 2021). The novelty of this new approach lies in the fact that while the quantum corrections due to the huge mass of the right handed neutrinos involved in the Type-I seesaw worsen the big hierarchy problem, the corrections from the Spin-3/2 field solve the same problem at a certain value of mass which happens to fall in the neutrino mass generation range. This advantage makes the Type-3/2 seesaw mechanism a very promising model. In this brief letter, with the investigation of radiative corrections to light neutrino masses via vector spinors we have shown that Type-3/2 seesaw mechanism is a stronger model inducing light neutrino masses, solving naturalness problem and also keeping the light neutrino masses stabilized.

The paper is organized as follows: In Sec.2 we give the basics of vector spinor fields, the constraints on them and introduce the interaction between the Higgs sector and vector spinor field. In Sec.3 we explain the Type-3/2 seesaw mechanism and give the radiative correction to neutrino masses via vector-spinor. Finally, Sec.4 is devoted to the comments and discussion.

2. MODEL

Vector spinor fields ψ_α , introduced by Rarita and Schwinger (Rarita and Schwinger, 1941) have the propagator

$$S^{\mu\nu}(p) = \frac{i}{p-M} \Pi^{\mu\nu}(p) \quad (1)$$

Carrying one Spin-3/2 proper and two auxiliary Spin-1/2 components through the projector

$$\Pi^{\mu\nu} = -\eta^{\mu\nu} + \frac{\gamma^\mu \gamma^\nu}{3} + \frac{(\gamma^\mu p^\nu - \gamma^\nu p^\mu)}{3M} + \frac{2p^\mu p^\nu}{3M^2} \quad (2)$$

These fields exhibit both spinor and vector characteristics and it is necessary to impose the two constraints (Pascalutsa, 2001; Pilling, 2005)

$$p^\alpha \psi_\alpha(p)|_{p^2=M^2} = 0 \quad (3)$$

and

$$\gamma^\alpha \psi_\alpha(p)|_{p^2=M^2} = 0 \quad (4)$$

to eliminate the two auxiliary Spin-1/2 components and make ψ_α satisfy the Dirac equation that is expected of an on-shell fermion.

The important implication that constraints (3) and (4) convey is that $p^\alpha \psi_\alpha(p)$ and $\gamma^\alpha \psi_\alpha(p)$ both vanishes on the physical shell (Demir et al., 2017).

As a singlet fermion, ψ_α , at the renormalizable level, makes contact with the SM through the neutrino portal

$$L_{int}^{H-L-\psi} = C_{3/2}^{ik} \bar{L}^i H \gamma^\alpha \psi_\alpha^k + h.c. \quad (5)$$

in which L^i is the lepton doublet ($i = 1,2,3$), H is the Higgs doublet with vacuum expectation value $v_H \approx 246 \text{ GeV}$ and ψ_α is the vector spinor with Lorentz index ($\alpha = 0,1,2,3$) and generation index ($k = 1,2,3$).

3. RADIATIVE CORRECTION TO LIGHT NEUTRINO MASSES VIA VECTOR SPINOR

In the recently proposed Type-3/2 seesaw mechanism (Demir et al., 2021) the light neutrino masses are induced in the same way as the Type-I seesaw mechanism via the diagram given in Figure 1.

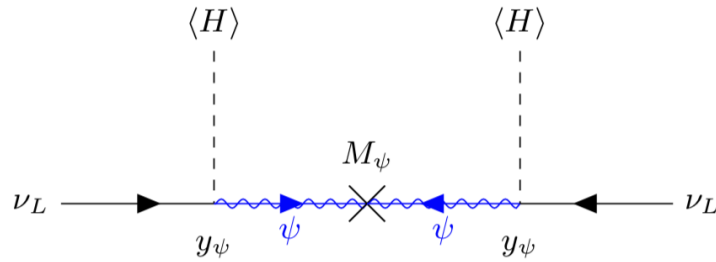

Figure 1. Diagrammatic representation of the Type-3/2 seesaw mechanism.

Type-3/2 seesaw mechanism induces the light neutrino masses as below

$$m_\psi = \frac{2C_\psi^2 \langle H \rangle^2}{9M_\psi} \quad (6)$$

in which only one kind of vector spinor is considered for convenience. It is obvious that, to be able to induce light neutrino masses compatible with the observations, the mass of vector spinor must be at least around 10^{14} GeV for a coupling constant $C_\psi \approx \mathcal{O}(1)$.

Considering the interaction (5) along with the constraint (4), it is easy to see that the natural habitat for the vector spinor ψ_α is loop diagrams. One such important loop diagram through which the effects of ψ_α manifest itself is the Higgs self-energy correction induced by the $\nu - \psi$ loop (Sargin, 2020).

Another equally important loop diagram is the neutrino mass correction induced by $H^0 - \psi$ loop and will be the subject of this section.

The interaction given in (5) leads to one loop correction to neutrino mass via the diagram given in Figure 2.

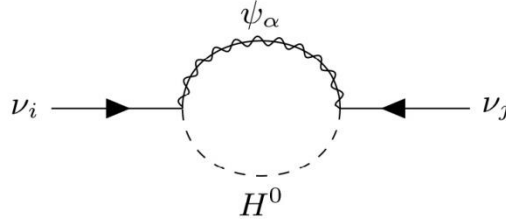

Figure 2. Higgs-vector spinor loop that contributes to the active neutrino masses in Type-3/2 seesaw mechanism.

The correction to active neutrino mass from $H^0 - \psi$ loop is given by

$$(\delta m_\nu)_\psi = -\frac{C_\psi^2}{24\pi^2} \frac{M_H^2}{M_\psi} \ln \frac{\mu^2}{M_H^2} \quad (7)$$

Radiative Corrections to Neutrino Mass in Type-3/2 Seesaw Mechanism

Here, C_ψ 's are pure numerical constants at the order of $\mathcal{O}(1)$ and the parameter $M_H = 125.6$ GeV. The value of μ does not change the value of the correction significantly. Thus, μ is fixed the value 1 TeV which is at the order of electroweak scale. Then, the only relevant parameter one is left with in determining the radiative corrections to neutrino masses is M_ψ .

In that regard, from the analysis depicted in Figure 3, it is seen that to stabilize the neutrino mass against the radiative correction by $H^0 - \psi$ loop, the mass of vector-spinor should be 2.8×10^{12} GeV or higher. When we consider this correction in Type-3/2 seesaw mechanism, the vector-spinor field with the mass at the order of 10^{14} GeV is more than capable of keeping the neutrino mass stable against radiative correction by $H^0 - \psi$ loop.

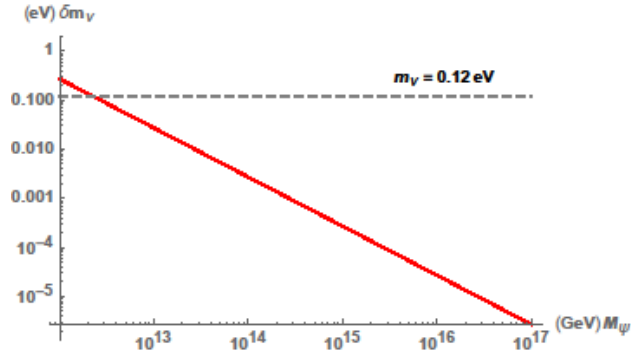

Figure 3. The radiative correctons to active neutrino masses vs the mass of Spin-3/2 field.

4. CONCLUSION

In this paper, we show that in novel Type-3/2 seesaw mechanism the light neutrino masses remain stabilized at loop level via vector spinors, which appear only in loops at renormalizable level. The mass of vector-spinor field required by inducing the active neutrino masses in Type-3/2 seesaw mechanism leads to trivial radiative corrections to the masses of light neutrinos. $M_\psi \approx 10^{14}$ GeV leads to $\delta m_\nu \approx 0.002$ eV corrections, which is in agreement with the upper bound on the lightest neutrino mass scale.

Canan Nurhan KARAHAN

ACKNOWLEDGEMENTS

The author sincerely thanks to Professor Durmuş Ali DEMİR and Dr. Ozan SARGIN for fruitful discussions.

CONFLICT OF INTEREST STATEMENT

The author declares no conflict of interest.

REFERENCES

- Ahriche, A., Jueid, A., and Nasri, S. (2018). "Radiative neutrino mass and Majorana dark matter within an inert Higgs doublet model". *Physical Review D*, Vol. 97, Issue 9, 095012. doi:10.1103/PhysRevD.97.095012.
- Babu, K. S., and Julio, J. (2012). "Radiative Neutrino Mass Generation through Vector-like Quarks". *Physical Review D*, Vol. 85, 073005. doi:10.1103/PhysRevD.85.073005.
- Balantekin, A. B., and Kayser, B. (2018). "On the Properties of Neutrinos". *Annual Review of Nuclear and Particle Science*, Vol. 68, 313-338. doi:10.1146/annurev-nucl-101916-123044.
- Bonilla, C., and Valle, J.W.F. (2016). "Naturally light neutrinos in *Diracon* model". *Physics Letters B*, Vol. 762, 162-165. doi:10.1016/j.physletb.2016.09.022.
- Cai, Y., Herrero-García, J., Schmidt, M. A., Vicente, A., and Volkas, R. R. (2017). "From the trees to the forest: A review of radiative neutrino mass models". *Frontiers in Physics*, Vol. 5, 63. doi:10.3389/fphy.2017.00063.
- Calle, J., Restrepo, D., Yaguna, C. E., and Zapata, Ó. (2019). "Minimal radiative Dirac neutrino mass models". *Physical Review D*, Vol. 99, Issue 7, 075008. doi:10.1103/PhysRevD.99.075008.
- Cheng, T. P., and Li, L. (1980). "Neutrino Masses, Mixings and Oscillations in SU(2) x U(1) Models of Electroweak Interactions". *Physical Review D*, Vol. 22, 2860. doi:10.1103/PhysRevD.22.2860.
- Demir, D. A., Everett, L. L., and Langacker, P. (2008). "Dirac Neutrino Masses from Generalized Supersymmetry Breaking". *Physical Review Letters*, Vol. 100, Issue 9, 091804. doi:10.1103/PhysRevLett.100.091804.
- Demir, D., Karahan, C., and Sargın, O. (2021). "Type-3/2 Seesaw Mechanism". *Physical Review D*, Vol. 104, Issue 7, 075038. doi:10.1103/PhysRevD.104.075038.

Demir, D., Karahan, C., Korutlu, B., and Sargin, O. (2017). "Hidden Spin-3/2 Field in the Standard Model". *The European Physical Journal C*, Vol. 77, 593. doi:10.1140/epjc/s10052-017-5164-3.

Foot, R., Lew, H., He, X. G., and Joshi, G. C. (1989). "See-saw neutrino masses induced by a triplet of leptons". *Zeitschrift für Physik C Particles and Fields* 44, 441-444. doi:10.1007/BF01415558.

Fukuda, Y., Hayakawa, T., Ichihara, E., Inoue, K., Ishihara, K., Ishino, H., ... Young, K. K. (Super-Kamiokande Collaboration). (1998). "Evidence for Oscillation of Atmospheric Neutrinos". *Physical Review Letters*, Vol. 81, Issue 8, 1562-1567. Retrieved from <https://journals.aps.org/prl/pdf/10.1103/PhysRevLett.81.1562>

Gell-Mann, M., Ramond, P., and Slansky, R. (1979). "Complex Spinors and Unified Theories". *Conf.Proc.C* 790927, 315-321.

Hehn, D., and Ibarra, A. (2013). "A radiative model with a naturally mild neutrino mass hierarchy". *Phys. Lett. B* 718, 988-991.

Herrero-García, J., and Schmidt, M. A. (2019). "Neutrino mass models: New classification and model-independent upper limits on their scale". *The European Physical Journal C* 79, 938. doi:10.1140/epjc/s10052-019-7465-1.

Hou, W., and Wong, G. (1994). "Radiative Majorana neutrino masses". *Physics Letters B* 339, 109-113.

Jana, S., Vishnu, P. K., and Saad, S. (2019). "Minimal dirac neutrino mass models from $U(1)_R$ gauge symmetry and left-right asymmetry at colliders". *The European Physical Journal C*, Vol. 79, 916. doi:10.1140/epjc/s10052-019-7441-9.

Klein, C., Lindner, M., and Ohmer, S. (2019). "Minimal Radiative Neutrino Masses". *Journal of High Energy Physics (JHEP)* 03, 018.

Ma, E., and Suematsu, D. (2009). "Fermion Triplet Dark Matter and Radiative Neutrino Mass". *Modern Physics Letters A*, Vol. 24, No. 08, 583-589.

Radiative Corrections to Neutrino Mass in Type-3/2 Seesaw Mechanism

- Nomura, T., Okada, H., and Orikasa, Y. (2017). "Radiative neutrino mass in alternative left-right model". *The European Physical Journal. C*, Vol. 77, Issue 2, 103. doi:10.1140/epjc/s10052-017-4657-4.
- Nomura, T., Okada, H., and Uesaka, Y. (2021). "A radiatively induced neutrino mass model with hidden local U(1) and LFV processes $l_i \rightarrow l_j \gamma, \mu \rightarrow e Z'$ and $\mu e \rightarrow ee$ ". *Journal of High Energy Physics (JHEP)* 01, 016.
- Pascalutsa, V. (2001). "Correspondence of consistent and inconsistent spin - 3/2 couplings via the equivalence theorem". *Physics Letters B*, Vol. 503, Issues 1–2, 85-90.
- Pilling, T. (2005). "Symmetry of massive Rarita-Schwinger fields". *International Journal of Modern Physics A*, Vol. 20, No. 13, 2715-2742.
- Rarita W., and Schwinger J. (1941). "On a Theory of Particles with Half-Integral Spin". *Phys. Rev.* Vol. 60, Issue 1. doi:10.1103/PhysRev.60.61.
- Saad, S. (2019). "Simplest Radiative Dirac Neutrino Mass Models". *Nucl. Phys. B*, Vol. 943, 114636.
- Sargin, O. (2020). "Fine-tuned Spin-3/2 and the Hierarchy Problem". *Advances in High Energy Physics*, Vol. 2020. doi:10.1155/2020/7589025.
- Schechter, J., and Valle, J.W.F. (1980). "Neutrino Masses in SU(2) x U(1) Theories". *Phys. Rev. D*, Vol. 22, 2227.
- Simirnov, A. (2003). "The MSW effect and solar neutrinos". *arXiv: 0305106 [hep-ph]*.
- Wang, W., and Han, Z.-L. (2017). "Naturally Small Dirac Neutrino Mass with Intermediate SU(2)_L Multiplet Fields". *Journal of High Energy Physics (JHEP)* 04, 166. doi:10.1007/JHEP04(2017)166.
- Yao, C.-Y., and Ding, G.-J. (2018). "Systematic analysis of Dirac neutrino masses from a dimension five operator". *Phys. Rev. D*, Vol. 97, Issue 9, 095042. doi:10.1103/PhysRevD.97.095042.

RESEARCH ARTICLE

**An ethical committee approval and/or legal/special permission has not been required within the scope of this study.*

**PHOTOVOLTAIC SYSTEM DESIGN AND ANALYSIS AT
FACULTY SCALE***

Sevgi ALTINKÖK¹
Serdar KARADENİZ²
Atılğan ALTINKÖK³

¹*Kocaeli University, Department of Energy Systems Engineering, Kocaeli,
Turkey,
216171003@kocaeli.edu.tr; ORCID: 0000-0001-8758-8174*

²*Giresun University, Department of Energy Systems Engineering, Giresun,
Turkey,
serdar.karadeniz@giresun.edu.tr; ORCID: 0000-0002-1792-8134*

³*National Defence University, Turkish Naval Academy, Department of
Electrical and Electronics Engineering, Istanbul, Turkey,
aaltinkok@dho.edu.tr; ORCID: 0000-0002-0548-4361*

Received: 16.02.2022

Accepted: 07.03.2022

Sevgi ALTINKÖK, Serdar KARADENİZ, Atılgan ALTINKÖK

ABSTRACT

In this study, it is aimed to develop a suitable photovoltaic system design for the needs of Giresun University Faculty of Engineering. After the determination of the number of panels required for the photovoltaic system by mathematical equations, a 3-dimensional layout planning was made on the roofs of the Engineering building using the PVSol program thus the required equipment was determined for the system. After simulation of the photovoltaic system and determination of the equipment compatible with the system was done, some parameters such as cost calculations, financial analysis and self-paying of the system were determined by the PVSol simulation program and the results were analyzed.

Keywords: *Renewable Energy, Solar Energy, Power Generation, Photovoltaic.*

FAKÜLTE ÖLÇEĞİNDE FOTOVOLTAİK SİSTEM TASARIMI VE ANALİZİ

ÖZ

Bu çalışmada, Giresun Üniversitesi Mühendislik Fakültesinin ihtiyaçlarına uygun fotovoltaik sistem tasarımı geliştirilmesi amaçlanmıştır. Fotovoltaik sistem için gerekli olan panel sayısı matematiksel denklemlerle tahmini olarak belirlendikten sonra PVSol programı kullanılarak Mühendislik binası çatılarında 3 boyutlu olarak yerleşim planlaması yapılmış ve sistem için gerekli olan ekipmanlar belirlenmiştir. Fotovoltaik sistemin simülasyonu gerçekleştirildikten ve sisteme uyumlu ekipmanlar belirlendikten sonra PVSol simülasyon programı yardımıyla maliyet hesaplamaları, finansal analizleri ve sistemin kendini amorti etmesi gibi farklı parametreler belirlenmiş olup sonuçları analiz edilmiştir.

Anahtar Kelimeler: *Yenilenebilir Enerji, Güneş Enerjisi, Enerji Üretimi, Fotovoltaik.*

1. INTRODUCTION

A large part of the energy produced in the world is still obtained from fossil fuels such as coal, oil and natural gas. The search for new energy has gained importance since fossil energy sources are not renewable and have negative environmental effects. There are six main renewable energy sources; these are bioenergy, geothermal energy, hydroelectric energy, ocean energy, wind energy and solar energy (Ellabban et al., 2014). Renewable energy sources are clean energy sources that have much lower environmental impacts such as CO₂ emissions compared to traditional energy technologies. In recent years, energy production with renewable energy sources has increased and constitutes a good alternative to fossil fuels for the future (Chiu and Chang, 2009).

Solar energy is one of the most important sources of renewable energy (International Energy Agency, 2011). Technologies developed to take advantage of solar energy not only increase the amount of solar energy use, but also reduce infrastructure costs. Solar energy, which meets its investment in a short time with its low investment cost and high efficiency, is a costless and environmentally friendly energy source (Masterson, 2021; Sulukan, 2020).

In order to meet the increasing energy demands, Turkey imports energy to a large extent and especially uses fossil fuels. It imports about three quarters of the total energy needed in our country. Therefore, expanding domestic and national renewable energy resources, reducing foreign dependency and increasing energy efficiency should be one of Turkey's energy priorities (Varlık and Yılmaz, 2017).

Our country is in an advantageous geographical position for solar energy. According to Turkey's Solar Energy Potential Atlas (General Directorate of Energy Affairs, n.d.);

- Average annual total sunshine duration = 2741.07 hours/year,
- Average daily total sunshine duration = 7.50 hours/day,
- Average annual total radiation intensity = 1527.46 kWh/m²-year,

- Average daily total radiation intensity = 4.18 kWh/m²-day,

calculated as (Ministry of Energy and Natural Resources of Republic of Turkey, 2020). Thanks to the solar power plants that can be established in our country, which has regions that receive sunlight during all four seasons of the year, a significant part of the energy need can be met.

As a renewable resource, solar energy provides energy without any pollutant effects and greenhouse gas emissions. Thus, it contributes to the development of sustainable energy as well as reducing the negative effects of global warming (TÜİK, 2020).

Photovoltaic systems are formed as a result of bringing together needed equipment such as photovoltaic panels and such as to provide the desired current and voltage. Depending on the system configuration, there are three main types of PV systems. These are: off grid systems, on grid systems, hybrid systems.

In this study, a hybrid PV system that both supports battery and generates electricity depending on the electricity grid is used. Hybrid systems can be thought of as an upgraded on-grid system to include a battery backup. This system has a deep-cycle battery bank that can be charged by both the electricity grid and solar panels. Thus, in the event of an outage, the backup battery can be turned on to provide backup power to the building and can be used for an alternative power source in case of photovoltaic system operation or failure, until the grid problem is resolved.

2. RESEARCH FINDINGS

2.1. Solar Energy Potential

This study on the distribution of sunshine duration for Turkey was carried out using the daily total sunshine duration data measured at the stations of the Turkish State Meteorological Service (MGM) between the years 1988-2017. Sunlight time measurements, which have been made with heliograph

devices for many years within the body of MGM, have been made with sundial measurement devices mounted on Automatic Meteorology Observation Stations (OMGI) since the 2000s. According to the total daily sunshine duration for the years 1988-2017 calculated for Turkey, the lowest average annual sunshine duration was measured in 1988 with 6.37 hours, and the highest sunshine duration was measured in 1990 with 7.30 hours (MGM, n.d.).

While calculating the solar system installation, solar panel calculation is made according to factors such as the sunshine duration information, as well as the factors such as at which hours the system will be used the most, in which seasons the system will be used intensively, the exact location of the system, and the amount of designed stored energy. For example, if a system is to be used in all seasons, it should be designed for winter sundials. Designed with an average of 7 hours a day, the system will be insufficient in winter. Similarly, if a system is designed to be used only in the summer months, extreme costs will be avoided if the average duration of sunlight in the summer months of the region is considered. Figure 2.1 shows the average duration of sunlight in Turkey by months.

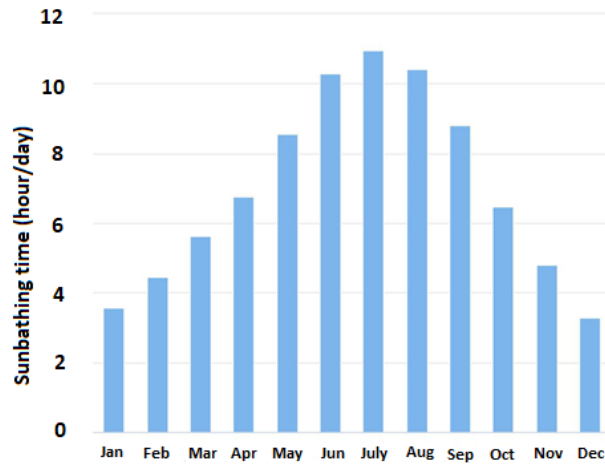

Figure 2.1. Turkey's sunshine duration by month (MGM, n.d.).

Photovoltaic System Design and Analysis at Faculty Scale

As it can be seen in Figure 2.1, the average, which rises to 11 hours in summer, decreases to 3 hours due to shorter days in winter, the sun reaching the panel with a more horizontal angle, and the weather being cloudier. In order not to interrupt off-grid solar energy systems in winter, seasonal changes should be considered, and the system should be designed according to the purpose of use.



Figure 2.2. Turkey sunshine duration distribution map (MGM, n.d.).

Obtaining the data closest to the location of the system will give more accurate results than making a calculation based on the average value of Turkey. Figure 2.2 shows the annual periods of sunlight and the average radiation intensity by region. Monthly sunshine and rainy days of the provinces are important for solar energy system design (MGM, n.d.).

Solar energy potential is an important parameter in determining the need for a solar panel for the system to be installed. The solar energy potential shows how much the sun's rays fall in which city and in which month.

Figure 2.3 shows the global solar radiation values of Giresun province and the solar energy potential according to the districts. According to this map, the districts with the highest solar energy potential are Alucra, Şebinkarahisar and Çamoluk. Figure 2.4 shows the average daily radiation values for Giresun province by month.

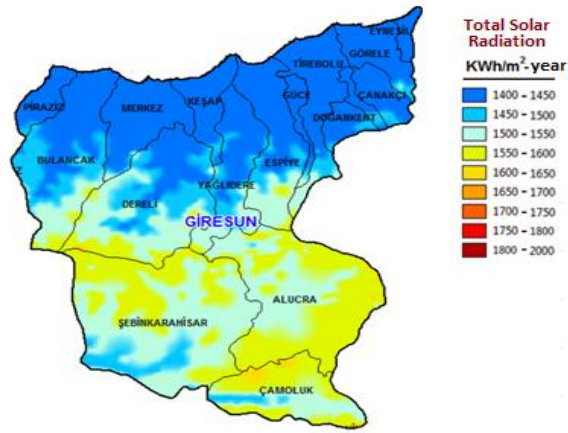

Figure 2.3. Total solar radiation values in Giresun province (General Directorate of Energy Affairs, n.d.).

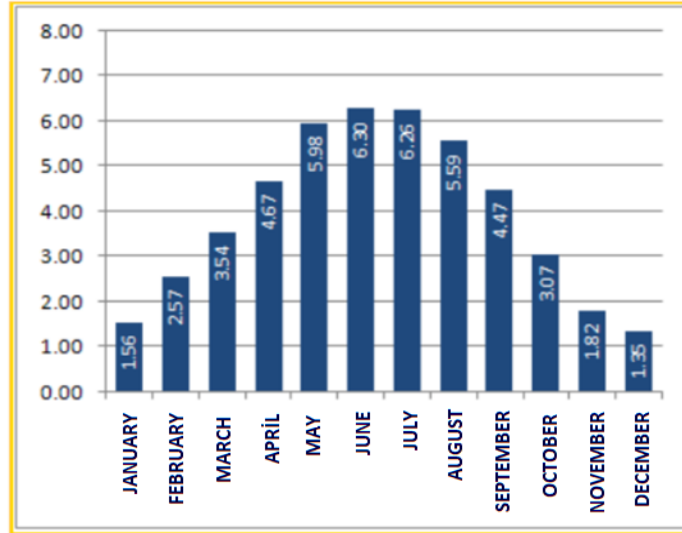

Figure 2.4. Global radiation values in Giresun province (kWh/m²-day) (General Directorate of Energy Affairs, n.d.).

The angle of incidence of the sun's rays in the Black Sea is inefficient, moreover, due to the climate of the region, it rains constantly, the time of the sun falling on the region is less. For this reason, the potential of solar energy will be less than in the Mediterranean region, which receives more sun. Figure 2.5 shows the average monthly sunshine periods for Giresun. According to the data in Figure 2.5, in the province of Giresun, the duration of the month 9.00 average sunshine hours is the highest of June, with the lowest average sunshine duration of hours 3.05 in December.

A grid-connected PV system consists of solar panels, inverters, a power conditioning unit, and grid-connecting equipment. Since there is no loss of energy storage, it effectively uses the energy generated from solar energy. Under favorable conditions, the grid-connected PV system provides more power than the grid-connected load can consume.

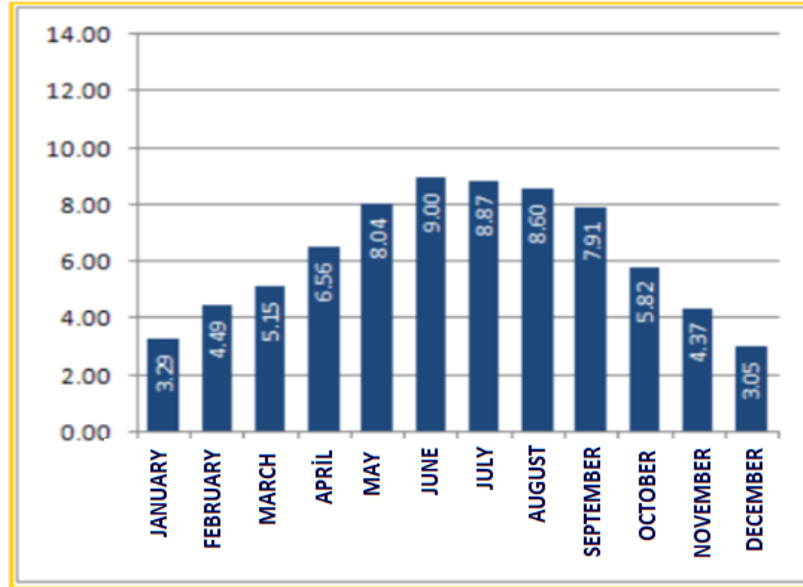

Figure 2.5. Giresun province sunshine durations (hours) (General Directorate of Energy Affairs, n.d.).

If the system to be installed is to be used only in summer, the daily average of the summer months should be found. However, if the system to be installed is to be used in summer and winter, the calculation should be made by looking at the daily production of the lowest electricity production month.

2.2. Determination of Energy Needs

As Giresun University Faculty of Engineering will be actively used at all times of the year, there will not be the same level of power consumption every month of the year due to changing sun exposure times, air conditioning loads in summer and more lighting loads in winter.

If the solar system will be used in all seasons, calculations should be made according to the winter sunshine hours. Thus, the system to be established

Photovoltaic System Design and Analysis at Faculty Scale

will provide sufficient energy even in the months when electricity is produced at the lowest level. Looking at Figure 4.5, since the lowest sunshine value for Giresun province is in December, this value will be used in the calculations.

At the first stage, it should be known how much electrical energy will be needed for the solar system that we plan to install on the roof, and it should be calculated how many solar panels will be used in this context.

For this purpose, Giresun University Faculty of Engineering December 2020 electricity bill information is given in Table 4.1. The monthly incoming electricity bill showed that 22,591 kWh of energy was used during the month of December and consumed an average of 728,7419 kWh of energy per day.

Table 2.1. Giresun University Faculty of Engineering December Billing Information.

Average Daily Consumption (kWh)	728,741
Monthly Consumption (kWh)	22.591
Annual Consumption (kWh)	263.482

In Figure 2.5, it is seen that the solar panels receive 3.05 hours of sunshine in Giresun in December. Equation 2.1 given below is used to calculate the number of panels.

$$NP = \frac{DEN(Wh) \times SE}{PGM(W) \times ASTD(h)} \quad (\text{piece}) \quad (2.1)$$

NP = Number of Panels,
DEN = Daily Energy Need,
SE = System Efficiency,

PGM = Power Generated by a Module,
ASTD = Average Sun Time per Day.

Here the system efficiency is assumed to be approximately 1 for an account. According to this formula, when using a 300W panel, about 797 solar panel systems will meet all the energy needs of the Giresun University Faculty of Engineering when using a 300W panel.

If the 320W panel is used, the number of panels will be reduced to 747, and it can meet all the energy needs. These calculated panel values are valid for an off-grid system, and the installation cost and payback period may take many years depending on the systems connected to the grid.

If the system planned to be installed is to be used throughout the year, but the electricity consumption is not enough, a calculation should be made of the amount of energy consumption used for the entire year, considering that the electricity will be supplied from the grid. In Figure 2.1, to find the value of the average daily energy consumption from the amount of energy consumed per year,

$$\text{Daily Average Energy Consumption} = \frac{\text{Annual Consumption(W)}}{365} \quad (2.2)$$

the equation will be used. With the help of this equation, the Average Daily Energy Consumption is found to be 721.86 kWh. Figure 2.5 shows the monthly sunshine periods of Giresun province. Using these data, the average duration of sunlight for Giresun can be found by equation 2.3.

$$\text{AST} = \frac{\sum_1^{12} \text{MST(hour)}}{12} \quad (2.3)$$

AST= Average Sunshine Time,

MST=Average Monthly Sunshine time

Accordingly, the average duration of sunlight is obtained as 6.26 hours. In other words, the average monthly duration of sunlight is 6.26 hours. Using

equation 2.1, we can find the number of panels we need for a 320W panel. Accordingly, the number of panels is available in the amount of 360 pieces.

The system to be installed in this study will be used in both summer and winter months, but when solar energy is not enough; there will be a connection to the electrical network to avoid disruption in the use of electricity.

3. PHOTOVOLTAIC SYSTEM DESIGN

After determining the estimated energy needs of Giresun University Faculty of Engineering, the roof section on the southern facade, which receives the sun's rays most efficiently and has an approximate slope of 25° , was determined for the installation of solar panels. The placement of the designated solar panels was done with the PVSol simulation program, which can design 3D buildings.

In the PVSol simulation program, in order to add Giresun University Faculty of Engineering to the system, modeling was performed using the satellite image of the building in Figure 3.1.



Figure 3.1 Satellite view of Giresun University Engineering Faculty roof.

For the design of this project, a hybrid system with mains connection and battery boost was preferred. The MeteoSyn Climate database in the PVSol

program contains about 450 climate data for Germany for the years 1981-2010 and more than 8,000 climate data for the years 1986-2005 worldwide on the basis of meteonorm 7.0. Climate data can be easily selected on the map (Valentin Software, 2020).

In the simulation applied, there are climate data of Giresun province between 1991-2010. Accordingly, the annual solar radiation value of 1173 kWh/m² and the annual average temperature of 15° were obtained in real time for Giresun University Engineering Faculty. The AC data to be used in the simulation are entered into the system as in Table 3.1.

Table 3.1. AC mains.

Phase Number	3
Mains Voltage (single phase)	230 V
Displacement Power Factor (cos phi)	+/- 1

Thanks to the integration of Google Maps in the 3D modeling of the program, the roof image of the Faculty of Engineering was uploaded to the program through the program. When this image is loaded, the program automatically selects the most suitable facade for modeling - the southern facade. For Giresun province, located in the north of Turkey, the installation of photovoltaic panels facing south provides higher energy production. The annual consumption of Giresun University Faculty of Engineering is shown as 263.482 kWh in the electricity bill in Table 2.1 and these data are used in simulation calculations.

In addition to the amount of solar radiation, the most important factor in calculating the electrical energy to be generated is the characteristic of the photovoltaic module. The PVSol program has about 13,000 modules in its database. The photovoltaic module model used in this study is a model included in the database of the software. As a Solar Panel, a 327 W SunPower monocrystalline solar panel was preferred. Figure 3.2 shows the layout of 368 units of 327 W SunPower solar panels on an area of 600.1 m² selected.

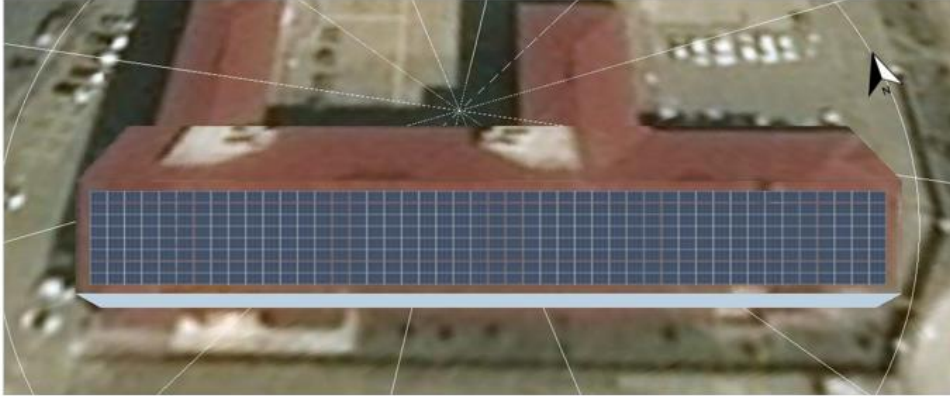

Figure 3.2. Module layout.

The dimensioning plan of the modules designed to be placed on the roof area is as in Figure 3.3.

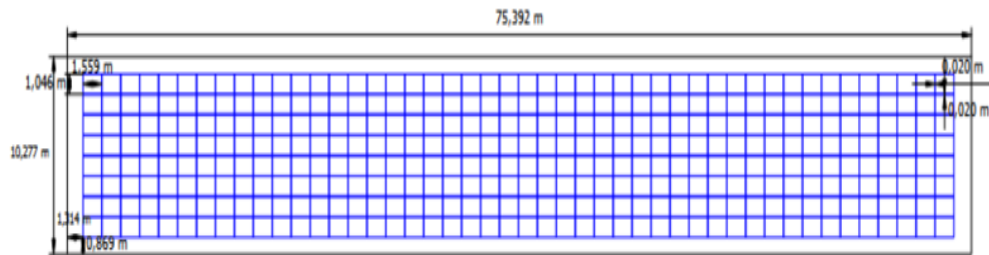

Figure 3.3. Dimensioning plan of modules.

The PVSol software with a 3D design editor draws 3D objects on the satellite map and performs the nearest realistic simulation to calculate the amount of shading. For the roof areas of the 3D buildings being drawn, the software automatically places the maximum number of modules on the roof. In addition, the selected suitable inverters are automatically configured. There are 3,100 inverter model specifications in the software database (Valentin Software, 2020).

Inverters are the most important photovoltaic system component to be considered after panels. When choosing an inverter, it should be noted that the maximum open-circuit voltage of the series-connected wire is higher than the inverter input voltage. In addition, it is necessary to choose an inverter with a power close to the power of the photovoltaic system, which is designed to be installed so that the inverters can work more efficiently. Huawei Technologies SUN2000-33KTL-A model 30kW inverter was selected for the system designed to be installed. The software program has set the required number of inverters for the system to be 4 units.

In the block diagram of the grid-connected photovoltaic system designed in Figure 3.4, there are 4 inverters in the first place, and a total of 16 MPPT is used for each inverter connected to these 4 inverters, 4 of which are connected to the grid. MPPTs connected to the first and second inverter are also divided into 2 string zones consisting of 12 modules. Further, the zones connected to the third and fourth inverter are divided into 2-string zones consisting of 11 modules.

Photovoltaic System Design and Analysis at Faculty Scale

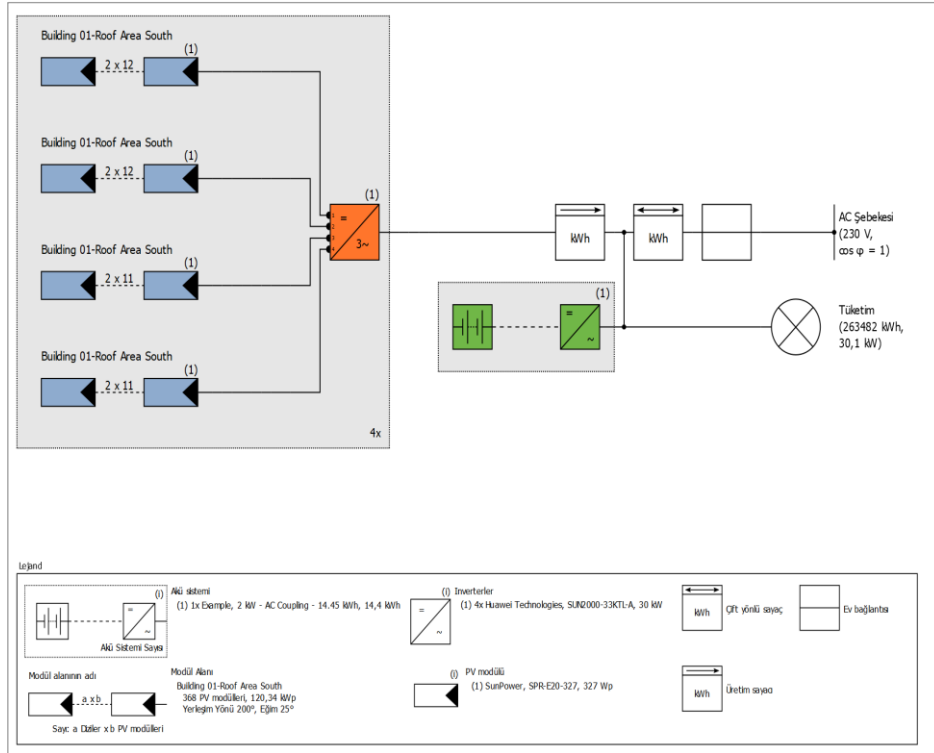

Batteries are used to store electrical energy on sunny days to use electrical energy on days when there is no solar energy or on days without solar energy. A battery group consisting of 12 batteries with battery energy of 14.4 kWh has been added to the system. It is generally not preferred to use it in such large-scale projects because battery groups are very costly, and their efficiency decreases after a certain number of years of use. In this study, a battery system was added to the simulation to provide energy to the system during the hours when there is no production, and the selected battery group is loaded alive for a year, and in cases where there is no production from solar energy, it is planned to provide energy to the system for about 6 hours.

The list of parts used in the system designed to be installed and the number of parts is listed in Table 3.2.

Table 3.2. Parts list.

Mat.No	Type	Manufacturer	Name	Quantity	Unit
1	PV module	Sun Power	SPR-E20-327	368	Piece
2	Inverters	Huawei Techn.	SUN2000- 33KTL-A	4	Piece
3	Battery System	Example	2 Kw-AC Coupling- 14,45 kWh	1	Piece
4	Counter		Production Counter	1	Piece
5	Counter		Bidirectional Counter	1	Piece

4. SIMULATION RESULTS

After the inputs of the system that is planned to be installed are added to the program and the equipment intended for use is determined, all the results of the system are taken graphically from a detailed project report and result screens. In Figure 4.1 there is a diagram of the energy flow, obtained because of the simulation of the designed solar power plant. According to this scheme, it has been calculated that the power plant installed on the roof of Giresun University Faculty of Engineering produces 138.054 kWh per year. 3,786 kWh of energy was stored in the battery groups and 3,167 kWh of energy was provided from the battery groups. According to the calculations in the simulation program, 86,681 kWh of the consumption of 263,523 kWh was obtained from the installed solar energy system, 173,682 kWh from the grid and 3,167 kWh from the battery group. In addition, according to the simulation program data, it was calculated that 47.609 kWh of energy will be sold to the grid when consumption is low.

Photovoltaic System Design and Analysis at Faculty Scale

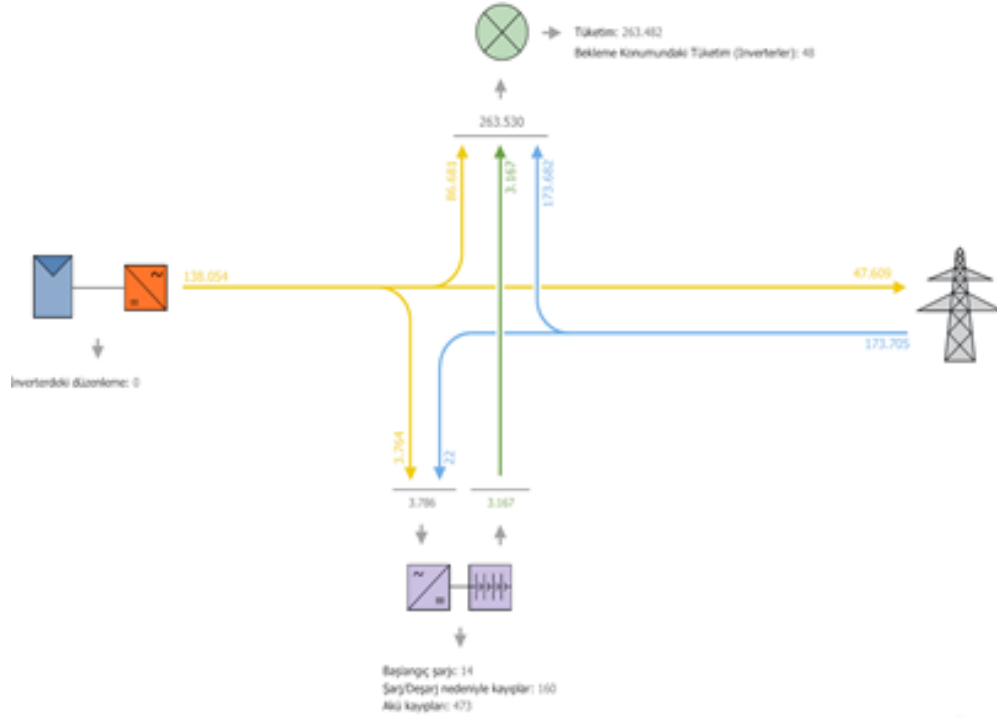

Figure 4.1. Energy flow graph.

The following input data is used to determine the evaluation dimensions:

- E_{in} = Energy radiated to the PV generator surface,
- EPV_{use} = Generated solar energy (on AC side) - own inverter consumption,
- E_{Load} = Electricity demand of devices,
- P_{nom} = Installed PV generator output,
- η_{STC} = Module efficiency under standard test conditions.

The specific annual efficiency is a measure of the number of hours that the PV system operates at full load for a year. The specific annual yield value is found with the help of the following equation.

$$\text{Annual Specific Earnings} = \frac{EPV_{\text{use}}(kWh)}{P_{\text{nom}}(kWp)} \quad (4.1)$$

The performance ratio defines the potential PV power generation efficiency in each system environment. The performance ratio is a measure of the energy losses in the system because it is compared with the energy output of the PV generator under standard test conditions (STC). The energy output under STC is determined by multiplying the modulus efficiency (η_{STC}) of the energy emitted on the PV array surface (E_{in}) by (Equation 4.2).

$$\text{Performance Ratio} = \frac{EPV_{\text{use}}(kWh)}{E_{\text{in}}(kWh)} \times \eta_{\text{STC}} \quad (4.2)$$

It consists of PV generator efficiency and inverter efficiency, considering system efficiency, wiring and battery losses. System efficiency is a measure used to convert the total amount of energy emitted by the PV system to the array surface (E_{in}) (Equation 4.3).

$$\text{System efficiency} = \frac{EPV_{\text{use}}(kWh)}{E_{\text{in}}(kWh)} \quad (4.3)$$

Table 4.1 contains a summary table of the installed photovoltaic system. Here, the annual energy gain of the PV system is 1,137.06 kWh and the utilization rate of the system is 90.5%. One of the biggest harms caused by the use of fossil fuels is the release of greenhouse gases such as CO₂. It has been calculated that the amount of CO₂ emissions that can be prevented by installing the system will be 65.105 kg per year. It is also calculated that the 263.482 kWh requirement of the Faculty of Engineering is met by 94.613 kWh of the PV system and 168.907 kWh of the network, so the autarky rating (self-sufficiency rating) of the system is 35.9%. The life of the battery pack installed in the system is 15 years, and it seems so.

Photovoltaic System Design and Analysis at Faculty Scale

Table 4.1. All system results.

PV System	
PV Generator Output	123 kWp
Annual Specific Earnings	1.137,26 kWh/kWp
System Usage Rate	90,5%
Loss of gain due to shadowing	0,0 % / Year
PV generator energy (AC grid)	139.8280kWh/Year
Avoided CO2 emissions	65.105 Kg/Year
Consumer	
Consumer	263.482 kWh/Year
Consumption in Standby (Inverters)	38 kWh/ Year
Total Consumption	263.520 kWh/ Year
Battery System	
Initial Charge	30 kWh
Battery Charge	9.324 kWh/ Year
Battery energy required to meet the consumption	8.046 kWh/ Year
Losses due to Charge/Discharge	563 kWh/ Year
Battery losses	744 kWh/ Year
Load Cycle	6,5 %
Lifetime	15 Year
Degree of autarky	
Total consumption	263.520 kWh/ Year
Consumption covered by the grid	168.907 kWh/ Year
Degree of autarky	35,9 %

In Figure 4.2, in the power generation table of the PV system by month, the yellow bars represent the amount of PV generator energy, the gray bars represent the amount of direct self-consumption, the blue bars represent the amount of mains supply, and the green bars represent the battery charge. According to this graph, almost all of the energy generated by the PV system was used. December may has the highest energy production, the highest in May and the lowest in November and December.

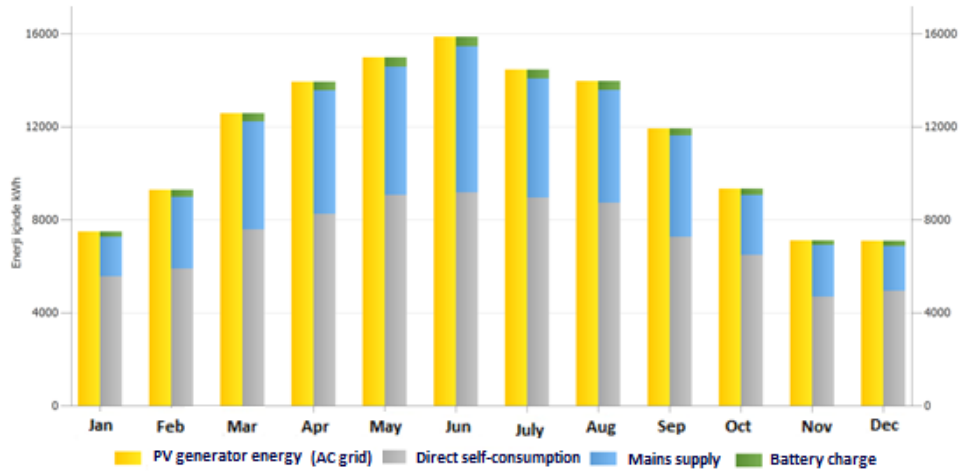

Figure 4.2 Use of the photovoltaic system.

In Figure 4.3, the gray bars represent the consumption in standby mode, the yellow bars represent the energy supplied by PV, the blue bars the energy supplied by the grid, and the green bars the energy amount met by the battery in the chart of the system to meet the consumption by months.

Photovoltaic System Design and Analysis at Faculty Scale

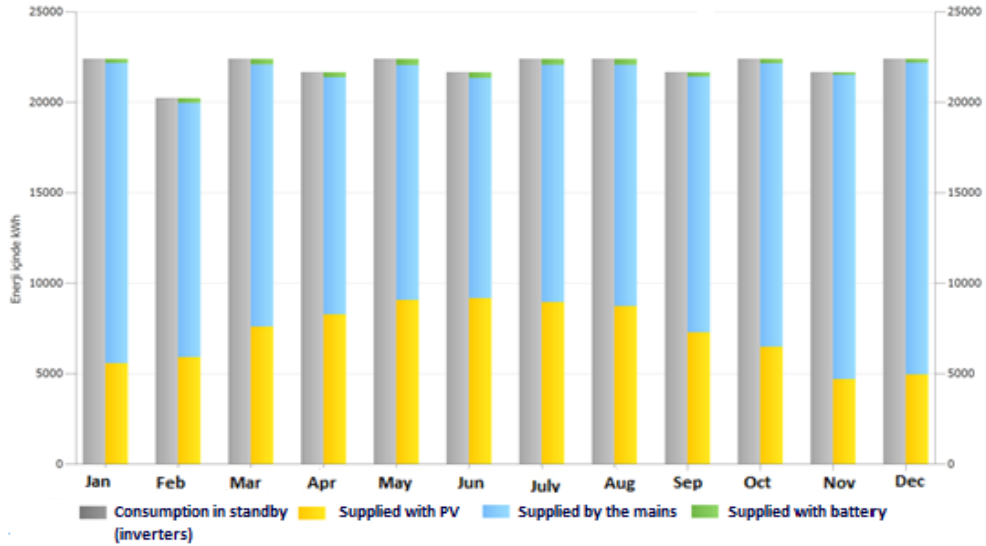

Figure 4.3. Graph of meeting the consumption of the system by months.

4.1. Financial Analysis

The calculation of economic efficiency with the PVSol program is calculated based on the capital value method using the following equations. The cash value (CV) of a price-dynamic payment sequence $Z, Z^*r, Z^*r^2 \dots$ over T years (lifetime).

$$CV=Z \times b(T,q,r) \tag{4.4}$$

CV = cash value, Z = series of payments and b = net worth factors
 The net worth factor is found with the help of equation 4.5 below.

$$b(T,q,r)=\begin{cases} \frac{1-(r/q)^T}{q-r} & r \neq q \\ \frac{T}{q} & r = q \end{cases} \quad (4.5)$$

q: Simple interest factor (e.g. 1.08 at 8 % simple interest)

r: Price change factor (e.g. 1.1 at 10 % price change)

The following applies for the net present value:

Net present value of the total investment = Σ [CV of the price-dynamic payment sequences over the lifetime] - investment + subsidies

Positive net present values indicate an investment which can be assessed as economically positive. The pay-back time is the period the system must operate for the investment to yield net present cash value of the overall investment of zero. Pay-back times of over 30 years are not supported.

Figure 4.4 shows the change in electricity bills before and after the photovoltaic system is installed and installed. In this table, the blue values indicate the values in the electricity bill before the PV system is installed, and the yellow values indicate the values in the electricity bill after the PV system is installed. According to the results of the analysis, the cash flow graph of the PV system is given in Figure 4.5. The system, which is projected to have a project life of 21 years, turns into a positive value after the first 7 years.

Photovoltaic System Design and Analysis at Faculty Scale

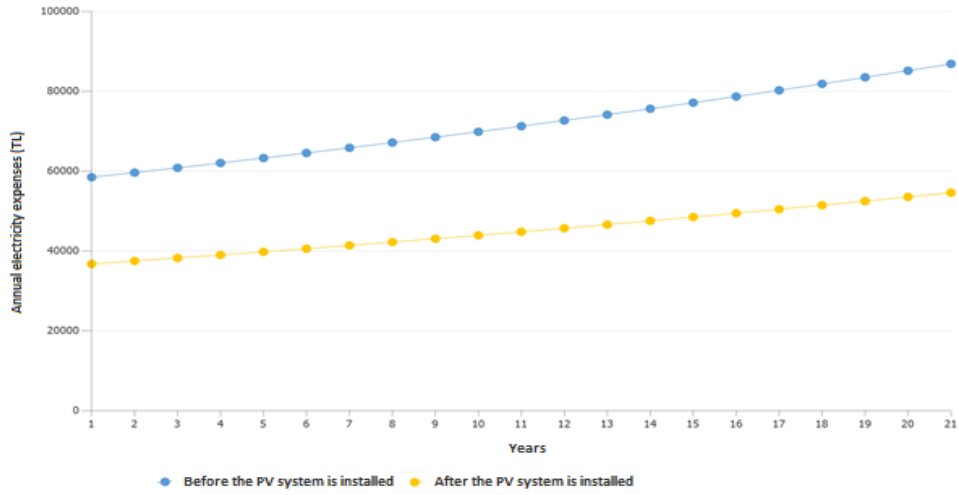

Figure 4.4. Electricity cost slope.

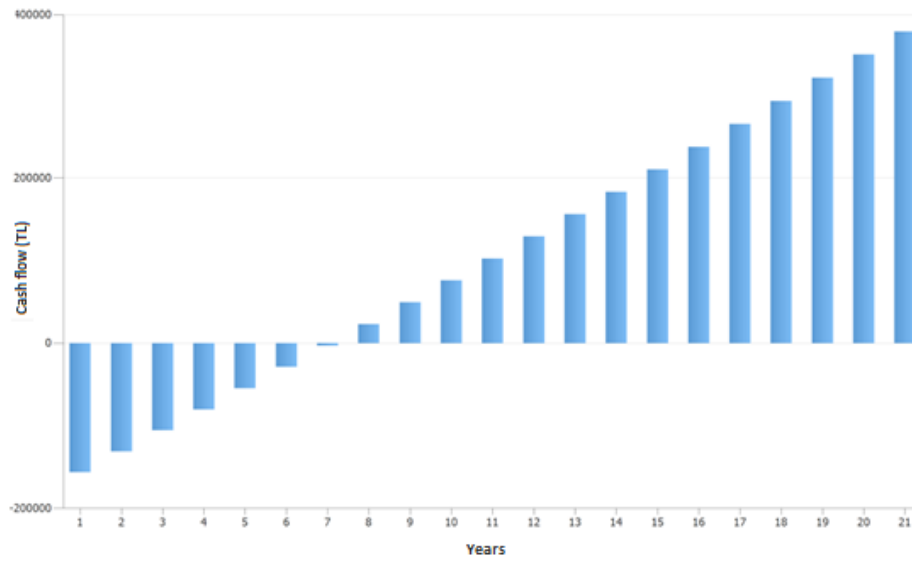

Figure 4.5. Cash flow chart.

Although solar energy systems are very costly in terms of economy, they can meet the initial investment costs in the first few years, due to their long life. The life of the simulated Giresun University Engineering Faculty Photovoltaic system is predicted to be 21 years, and after the first 7 years, there will be no extra expenses other than the maintenance costs that must be done periodically, and according to the unlicensed electricity generation law; an incentive fee is charged for each kilowatt of solar energy produced.

5. CONCLUSION

Photovoltaic system design developed for this study, solar radiation data was evaluated for the location of the system designed to be installed by the PVSol program, the appropriate roof facing south with an angle of 25° was selected by evaluating the roofs of the buildings, the components of the photovoltaic system were selected, and finally, the PV system connected to the grid was designed and financial analyzes were made.

The number of panels required for the photovoltaic system was calculated using equation 4.1 and the estimated number of panels was determined. Then, a 3D layout was made on the roof of the engineering building using the PVSol program and the necessary equipment for the simulation of the photovoltaic system was determined and the photovoltaic module, inverter and battery were compatible with the system such as the project design was made. With the help of PVSol simulation program, various parameters of the system such as cost calculations, financial analysis and self-wear were determined, and the technical and economic suitability of the designed system was examined.

Although solar energy systems are very costly in terms of economy, they can cover the initial investment costs in the first few years due to their longevity. The life of the simulated Giresun University Faculty of Engineering Photovoltaic system will be 21 years and the system will be 7. it is predicted that he will reproach himself in his year. According to the unlicensed electricity generation law, an incentive fee is charged for every kW of solar energy produced.

Photovoltaic System Design and Analysis at Faculty Scale

Analysis of the simulation results shows that when the project is implemented, Giresun University Faculty of Engineering will provide approximately 138.054 MWh of electricity, which is about 52% of the annual electricity consumption. The system, designed to be installed, also can save about 64,588 kg of CO₂ emitted by a crude oil-fired thermal power plant that produces the same amount of electricity.

According to the wage conditions prevailing in Turkey, this project may not be considered financially viable, except for the implementation of a guaranteed wage plan or other incentives such as grants/capital subsidies. However, there are other non-financial benefits, such as reducing greenhouse gas emissions.

Within the scope of this study, the solar energy system planned to be installed at Giresun University Faculty of Engineering provided an energy output of 120.34 kW with 368 photovoltaic modules of 327 W, 4 inverters and 1 battery system on an area of 600.1 m² on the roof of the faculty. From this work we can draw the following conclusions that will justify the viability of the solar energy system:

- This system produces 138,054 kWh energy units per year.
- The rate of return on capital investment is 14.30% per annum.
- The payback period of this system is approximately 7.1 years.
- The average performance rate of the system is 91.3% and the specific annual efficiency is 1147.24 kWh.
- In the case of using conventional power, the annual CO₂ emission is 64,588 kg.
- This study has been applied to the south-facing part of the Giresun University Roof, and if desired, it may be possible to expand the scope of the project to provide more energy production.

Sevgi ALTINKÖK, Serdar KARADENİZ, Atılgan ALTINKÖK

CONFLICT OF INTEREST STATEMENT

The authors declare no conflict of interest.

REFERENCES

Chiu, C.-L., and Chang, T.-H. (2009). "What proportion of renewable energy supplies is needed to initially mitigate CO2 emissions in OECD member countries?" *Renewable and Sustainable Energy Reviews*, Vol. 13, Issues 6-7, 1669-1674. doi:10.1016/j.rser.2008.09.026.

Ellabban, O., Abu-Rub, H., and Blaabjerg, F. (2014). "Renewable energy resources: Current status, future prospects and their enabling technology". *Renewable and Sustainable Energy Reviews*, Vol. 39, 748-764. doi:10.1016/j.rser.2014.07.113.

General Directorate of Energy Affairs (n.d.). "Güneş Enerjisi Potansiyel Atlası (GEPA)". Retrieved from <https://gepa.enerji.gov.tr/MyCalculator/pages/28.aspx>

International Energy Agency (2011). "Solar Energy Perspectives: Executive Summary". *International Energy Agency (IEA)*. Archived from the original (PDF) on 13 January 2012.

Masterson, V. (2021, 05 July). "Renewables were the world's cheapest source of energy in 2020, new report shows". *World Economic Forum*. Retrieved from https://www.weforum.org/agenda/2021/07/renewables-cheapest-energy-source/?utm_source=twitter&utm_medium=social_scheduler&utm_term=Future+of+Energy&utm_content=07/07/2021+00:00

Ministry of Energy and Natural Resources of Republic of Turkey (n.d.). "Güneş Enerjisi". Retrieved from www.enerji.gov.tr/gunes-bilgimerkezi

Sulukan, E. (2020). "Techno-economic and environmental analysis of a photovoltaic system in Istanbul". *Pamukkale University Journal of Engineering Sciences*, 26(1), 127-132.

Sevgi ALTINKÖK, Serdar KARADENİZ, Atılgan ALTINKÖK

Turkish State Meteorological Service (MGM) (n.d.). “Türkiye Ortalama Güneşlenme Süresi (1991-2020)”. Turkish State Meteorological Service (MGM). Retrieved from <https://www.mgm.gov.tr/kurumici/turkiye-guneslenme-suresi.aspx>

Turkish Statistical Institute (TÜİK) (2020, 31 March) “Sera Gazı Emisyon İstatistikleri, 1990-2018”. TÜİK News Bulletin, No. 33624. Retrieved from <https://data.tuik.gov.tr/Bulten/Index?p=Sera-Gazi-Emisyon-Istatistikleri-1990-2018-33624>

Valentin Software (2020). “The design and simulation software for photovoltaic systems”. Retrieved from <https://valentin-software.com/en/products/pvsol-premium/>

Varlık Günüşen, İ., and Yılmaz, A. (2017). “Türkiye Ekonomisinde Yenilenebilir Enerji Projelerinin Gerçekleştirilmesinde Sorunlar ve Çözüm Önerileri”. *Finans Politik & Ekonomik Yorumlar*, Vol. 54, Issue 623, 51-62.

**An ethical committee approval and/or legal/special permission has not been required within the scope of this study.*

**A GOLDEN SECTION METHOD FOR THE MULTI-OBJECTIVE
FRACTIONAL SOLID TRANSPORTATION PROBLEM USING
THE EXPONENTIAL MEMBERSHIP FUNCTION***

Nurdan KARA¹
Hale GONCE KÖÇKEN²

¹*National Defence University, Department of Mathematics, İstanbul,
Turkey,*
nurdancetin@gmail.com; ORCID:0000-0001-6195-288X

²*Yildiz Technical University, Department of Mathematical Engineering,
İstanbul, Turkey,*
hgonce@yildiz.edu.tr; ORCID: 0000-0003-1121-7099

Received: 24.02.2022

Accepted: 28.03.2022

Nurdan KARA, Hale GONCE KÖÇKEN

ABSTRACT

The multi-objective Solid Transportation Problem (MSTP) is type of vector minimization (or maximization) problem with three parameters: source, destination, and mode of transport. It may have fractional objective functions in real-life applications to maximize the profitability ratio like profit/cost or profit/time. We refer to such transportation problems as the Multi-objective Fractional Solid Transportation Problem (MFSTP). In this article is presented a fuzzy approach that combines the usage of linear programming and the golden section algorithm with linear and exponential membership functions and a strongly efficient solution is obtained. Finally, a numerical example from the literature is solved to show the solution algorithm and a comparison is presented with the solution found by using a linear membership function.

Keywords: *Solid Transportation Problem, Fractional Programming, Exponential Membership Function, Fuzzy Programming, Golden Section Method.*

**ÇOK AMAÇLI ÜÇ BOYUTLU KESİRLİ TAŞIMA PROBLEMİ İÇİN
ÜSTEL ÜYELİK FONKSİYONU KULLANARAK ALTIN ORAN
METODU**

ÖZ

Çok amaçlı üç boyutlu taşıma problemi kaynak, varış yeri ve taşıma şekli parametrelerine sahip vektör minimizasyon (veya maksimizasyon) probleminin özel bir tipidir. Amaçları, kârlılık oranınının- kâr/maliyet veya kâr/zaman- maksimizasyonu gibi iki lineer fonksiyonun oranı olabilir. Bu tür problemler, Çok Amaçlı Kesirli Üç Boyutlu Taşıma Problemi olarak adlandırılmaktadır. Bu çalışmada, lineer programlama ve altın oran yönteminin lineer ve üstel üyelik fonksiyonları ile kullanıldığı bulanık bir yaklaşım sunulmakta ve pareto-optimal bir çözüm elde edilmektedir. Son olarak, çözüm yöntemini göstermek için literatürden sayısal bir örnek çözülmüş ve doğrusal üyelik fonksiyonu kullanılarak elde edilen çözümle bir karşılaştırma yapılmıştır.

Anahtar Kelimeler: *Üç Boyutlu Taşıma Problemi, Kesirli Programlama, Üstel Üyelik Fonksiyonu, Bulanık Programlama, Altın Oran Metodu.*

1. INTRODUCTION

In the present day, transportation problems have extra conveyance constraints such as product type or mode of transportation. In this case, the Solid Transportation Problem (STP) is obtained as a type of single objective transportation problem.

There are many different situations due to uncertainty. To deal with such cases, fuzzy decision-making method should be used. Therefore, an adaptation of fuzzy set theory in the solution method increases the flexibility and effectiveness of the proposed approaches. This theory has been used for the development of the applications of solid transportation. Most research investigates MSTP under the fuzzy environment in two cases: (1) the costs, the supplies, the demands, and conveyances capacities are fuzzy numbers (2) All parameters are crisp while the fuzzy programming approach is used.

(Cui & Sheng, 2013) defined a STP with expected constrained depending on fuzzy programming. A new procedure using based on the zero-point process is proposed to generate an optimal solution of STP by (Pandian & Anuradha, 2010). (Sobana & Anuradha, 2018) gave a procedure obtaining an optimal solution for STP using α -cut under an imprecise environment. Concerning MSTP, (Bit, Biswal, & Alam, 1993) and (Cadenas & Jimenez, 1994) presented some solution methods. (Jimenez & Verdegay, 1998; 1999) gave the solution method both interval and fuzzy STP. (Gen, Ida, Li, & Kubota, 1995) dealt with a genetic algorithm for the solution of the multi-criteria STP in which all constraints were fuzzy numbers. (Anitha, Venkateswarlu, & Akilbasha, 2021) gave an innovative procedure to solve fully rough interval integer STP. (Li, Ida & Gen, 1997) introduced a genetic algorithm to find a solution to the fuzzy MSTP. An interactive fuzzy satisfying method was given for MSTP by (Tao & Xu, 2012). (Dalman, 2016) gave a fuzzy approach to find a solution for interval MSTP. (Anuradha, Jayalakshmi, Deepa, & Sujatha, 2019) explained the procedure that finds to solve for the bi-objective STP using fuzzy linear membership functions. A general formulation of the MSTP with some random parameters is dealt with by (Singh, Pradhan, & Biswal, 2019). (Ojha, Das, Mondal & Maiti, 2009) dealt with a fully fuzzy version of MSTP using fuzzy numbers such as trapezoidal and triangular (Nagarajan, Jeyaraman, & Krishna, 2014) solved MSTP with interval cost in source and demand

*A Golden Section Method for the Multi-objective Fractional Solid
Transportation Problem Using the Exponential Membership Function*

parameters. (Ammar & Khalifa, 2014) gave MSTP having fuzzy parameter. (Ida, Gen, & Li, 1995) solved multicriteria STP with fuzzy numbers by genetic algorithms. (Kumar & Dutta, 2015) proposed to base on expected value and the goal programming approach for solving fuzzy MSTP.

A STP with two or more fractional objective functions is referred to as a MFSTP. (Radhakrishnan & Anukokila, 2014) dealt with an interval STP applying fractional goal programming. A capacitated MSTP was defined as a constrained nonlinear problem and solved using Interactive Fuzzy Method and Gradient method by (Ojha, Mondal, & Maiti, 2014). (Jana & Jana, 2020) formed a solution method for STP with additional constraints and optimized through fuzzy and fractional programming methods. (Basu & Acharya, 2002) dealt with bi-criterion quadratic fractional STP and developed a method. In (Khalifa & Al-Shabi, 2018), a fully fuzzy multi-objective linear fractional programming is given for multi-product problems. (Khalifa, 2019) investigated a fractional multi-objective multi-product STP with interval costs, supply, demand, and conveyances. (Khalifa, Kumar, & Alharbi, 2021) presented fuzzy geometric programming approach by using membership function to obtain compromise solution of multi-objective fractional two-stage STP.

This paper is presented three-dimension MFSTP having fractional objectives and transportation constraints. In the proposed fuzzy solution method, after linear and exponential membership functions are constructed, the min operator model is obtained. This model is solved using a fuzzy method combining linear programming with the golden section algorithm. To show solution procedure a numerical example is applied.

This article is organized as follows. In Section 2 is presented the formulation of MFSTP with mixed constraints. Section 3 expresses the solution method of the problem using a golden section algorithm. A numerical example is given in Section 4. The last section ends some conclusions.

2. MULTI-OBJECTIVE LINEAR FRACTIONAL TRANSPORTATION PROBLEM WITH MIXED CONSTRAINTS

In fractional STPs, the constraints are not commonly presented with equalities. However, in many instances, it can be possible to encounter situations where the supply, demand and mode of transport constraints are “greater than or equal to” or “less than or equal to”. Therefore, MFSTP with mixed constraints is discussed in this study in terms of being a more realistic model.

The aim of the problem is to obtain the minimum cost ratio for transporting a production from m supplies to n demands via K conveyances, whose capacities are a_i , $1 \leq i \leq m$; b_j , $1 \leq j \leq n$, and e_k , $1 \leq k \leq K$, respectively. $c_p = [c_{ijk}^p]_{m \times n}$ and $d_p = [d_{ijk}^p]_{m \times n}$ denote cost and profit matrix for the p-th objective functions, respectively. Also, the scalar c_0^p is constant cost and d_0^p is constant profit. The variable x_{ijk} expresses the unknown amount of the transported from source i to destination j through conveyance k , the mathematical model of MFSTP with mixed constraints is written following:

*A Golden Section Method for the Multi-objective Fractional Solid
Transportation Problem Using the Exponential Membership Function*

$$\min Z_p(\mathbf{x}) = \frac{N_p(x)}{D_p(x)} = \frac{\sum_{i=1}^m \sum_{j=1}^n \sum_{k=1}^K c_{ijk}^p x_{ijk} + c_0^p}{\sum_{i=1}^m \sum_{j=1}^n \sum_{k=1}^K d_{ijk}^p x_{ijk} + d_0^p}, \quad p=1, \dots, P \quad (1)$$

s.t.

$$\sum_j \sum_k x_{ijk} \geq a_i, i \in I_1; \sum_j \sum_k x_{ijk} = a_i, i \in I_2; \sum_j \sum_k x_{ijk} \leq a_i, i \in I_3 \quad (1.a)$$

$$i \in I_1 \cup I_2 \cup I_3 = I$$

$$\sum_k \sum_i x_{ijk} \geq b_j, j \in J_1; \sum_k \sum_i x_{ijk} = b_j, j \in J_2; \sum_k \sum_i x_{ijk} \leq b_j, j \in J_3 \quad (1.b)$$

$$j \in J_1 \cup J_2 \cup J_3 = J$$

$$\sum_i \sum_j x_{ijk} \geq e_k, k \in K_1; \sum_i \sum_j x_{ijk} = e_k, k \in K_2; \sum_i \sum_j x_{ijk} \leq e_k, k \in K_3 \quad (1.c)$$

$$k \in K = K_1 \cup K_2 \cup K_3$$

$$x_{ijk} \geq 0$$

where the subscripts $Z_p(x)$ and superscript c_{ijk}^p denote the p -th objective function, and $a_i, b_j, e_k > 0, c_{ijk}^p \geq 0, \forall i, j, k$. (1.a)-(1.c) are defined as supply, demand and conveyance constraints, respectively. Furthermore, $I_1, I_2,$ and I_3 correspond to “greater than or equal to”, “equal to”, and “less than or equal to” mode of constraints, respectively. $J_j, j=1,2,3$ and $K_k, k=1,2,3$ are also denoted in this way.

A set S that is compact and convex is called the feasible set of Problem (1).

In a multi-objective context, we often encounter the descriptions of efficient or non-dominated or strongly efficient solutions different from the optimal solution concepts.

Concerning the multi-objective linear fractional programming Pareto-optimal solution that is the standard definition of efficient solution is

insufficient and thus weakly efficient concept is paid attention to. Although obtaining the strongly efficient solutions is claimed in theory, solution approach tent to generate weakly efficient solutions, since the vertexes of E^W (Weakly efficient solutions set) design a connected graph. For MFSTP with mixed constraints will be got the definition of strongly efficient, weakly Pareto-optimal, compromise, compensatory compromise solution concepts.

Definition 2.1. $\mathbf{x}^* \in S$ is a strongly efficient solution iff there does not exist another feasible point \mathbf{x} such that $Z_p(\mathbf{x}) \leq Z_p(\mathbf{x}^*) \quad \forall p$, and $Z_p(\mathbf{x}) \neq Z_p(\mathbf{x}^*)$ for at least one p .

Definition 2.2. $\mathbf{x}^* \in S$ is a weakly pareto-optimal solution iff there does not exist another $\mathbf{x} \in S$ such that $Z_p(\mathbf{x}) < Z_p(\mathbf{x}^*)$, $\forall p$.

Under these definitions, $E^w \supset E^s$, here E^w indicates the weakly pareto-optimal solution set and E^s determines the set of strongly efficient solutions.

Definition 2.3. A feasible point $\mathbf{x}^* \in S$ is *compensatory compromise solution* if $\mathbf{x}^* \in E^s$ and $\mathbf{Z}(\mathbf{x}^*) \leq \min_{\mathbf{x} \in S} (\mathbf{Z}_1(\mathbf{x}), \mathbf{Z}_2(\mathbf{x}), \dots, \mathbf{Z}_p(\mathbf{x})) + \mathbf{I} \cdot \lambda_{\bullet}$, $\lambda_{\bullet} \geq 0$, the Q -dimensional column vector with \bullet th element 1 and others elements 0 is \mathbf{I} .

Definition 2.4. A feasible point $\mathbf{x}^* \in S$ is a *compromise solution* iff $\mathbf{x}^* \in E^w$ and $\mathbf{Z}(\mathbf{x}^*) \leq \min_{\mathbf{x} \in S} (\mathbf{Z}_1(\mathbf{x}), \mathbf{Z}_2(\mathbf{x}), \dots, \mathbf{Z}_p(\mathbf{x}))$.

3. A SOLUTION PROCEDURE FOR MFSTP WITH MIXED CONSTRAINTS

In the proposed solution procedure, both linear and exponential membership functions will be used. To present the method clearly, first, the linear membership function will be discussed in the following subsection.

3.1. Constructing the Linear Membership Functions

$$\mu_p(Z_p(\mathbf{x})) = \begin{cases} 1, & L_p > Z_p \\ \frac{Z_p(\mathbf{x}) - U_p}{L_p - U_p}, & L_p \leq Z_p < U_p \\ 0, & U_p < Z_p \end{cases} \quad (2)$$

where $\max_{\mathbf{x} \in S} Z_p(\mathbf{x}) = U_p$ and $\min_{\mathbf{x} \in S} Z_p(\mathbf{x}) = L_p$, $\forall p = 1, \dots, P$.

By defining a new auxiliary variable $\lambda = \min \mu_p(Z_p(\mathbf{x}))$, problem (1) can be transformed into using Zimmermann's "min" operator model:

$$\begin{aligned} & \max \quad \lambda & (3) \\ \text{s.t.} \quad & \mu_p(Z_p(\mathbf{x})) \geq \lambda, \\ & \mathbf{x} \in S, \forall p. \end{aligned}$$

The cooperative satisfactory degree of all objectives is represented by λ . Here, the "cooperative" refers to the lowest degree of satisfaction obtained for each objective of (1).

3.2. Constructing the Exponential Membership Function

Usage of the exponential membership function would give a more realistic conclusion than the linear ones in many real-life problems. Also, the satisfaction rate of exponential one is not always constant, as with linear one. Therefore, this non-linear membership function is preferred in this article.

The exponential membership function for an objective can be defined as

$$\mu_p^E(Z_p(\mathbf{x})) = \begin{cases} 1 - \exp\left(\frac{\alpha_p(Z_p(\mathbf{x}) - L_p)}{U_p - L_p}\right), & U_p \geq Z_p(\mathbf{x}) \geq L_p \\ 1, & Z_p(\mathbf{x}) < L_p \\ 0, & U_p < Z_p(\mathbf{x}) \end{cases} \quad (4)$$

where α_p is a shape parameter which is generally assumed as $\alpha_p = 3$.

Using (4), the fuzzy model can be written as:

$$\begin{aligned} & \max \lambda \\ \text{s.t.} \quad & \mu_p^E(Z_p(\mathbf{x})) = 1 - \exp\left(\frac{\alpha_p(Z_p(\mathbf{x}) - L_p)}{U_p - L_p}\right) \geq \lambda, \quad \forall p \\ & \mathbf{x} \in S. \end{aligned} \tag{5}$$

Problem (5) is rewritten by making mathematical arrangements as:

$$\begin{aligned} & \max \lambda \\ \text{s.t.} \quad & U_p + \ln(1 - \lambda) \cdot \left(\frac{L_p - U_p}{-\alpha_p}\right) \geq Z_p(\mathbf{x}), \\ & \mathbf{x} \in S, \quad \forall p. \end{aligned} \tag{6}$$

We note that, in the problem (6), provided the value of λ is constant, it could be transformed to a set of linear inequalities. Finding the optimal solution λ^* to the problem is equivalent to have an acceptable set that satisfies the constraints of the problem because of $0 \leq \lambda \leq 1$.

The proposed solution method for this problem can be given as follows.

3.3. Golden Section Method to MFSTP with Mixed Constraints

(Sakawa & Yumine, 1983) and (Sakawa & Yano, 1988) gave an interactive fuzzy procedure for solving MFTP, which is a combination of linear programming and the golden section algorithm.

In our paper, an algorithm based on this method is applied to MFSTP with mixed constraints. The non-linear (3) problem could be transformed into a set of linear inequalities if the value of λ is fixed. Finding the optimal solution λ^* to the problem is equivalent to obtain the maximum value of λ in order that there is an admissible set satisfying the constraints of (3). Because λ satisfies $\mu_{\min} \leq \lambda \leq \mu_{\min} + 1$, where μ_{\min} means the minimum value of μ_p , $\forall p$.

Following are the steps for Golden Section Method:

*A Golden Section Method for the Multi-objective Fractional Solid
Transportation Problem Using the Exponential Membership Function*

Step 1: Set $\lambda = \mu_{\min} = 0$ to test whether an admissible set satisfying the constraints of (3) exists or not. Provided an admissible set exists, go to Step 2. Otherwise, $\lambda^* = \mu_{\min}$. and STOP.

Step 2: Set $\lambda = \mu_{\min} + 1$, then test whether an admissible set satisfying the constraints of (3) exists or not. Provided an admissible set exists, set $\lambda^* = \mu_{\min} + 1$. Else, go to the next step since the maximum λ satisfying the constraints of (3) exist between μ_{\min} and $\mu_{\min} + 1$.

Step 3: Take $\lambda_1 = \mu_{\min} + \frac{\sqrt{5}-1}{2}$ as an initial value, and update the value of λ using the golden section algorithm as follows:

$$\begin{cases} \lambda_{n+1} = \frac{\sqrt{5}-1}{2^{n+1}} + \lambda_n, & \text{if admissible set exists for } \lambda_n \\ \lambda_{n+1} = \frac{1-\sqrt{5}}{2^{n+1}} + \lambda_n, & \text{if no admissible set exists for } \lambda_n. \end{cases} \quad (7)$$

That is, for $\forall \lambda$, test whether an admissible set of (3) exists or not, solve linear inequalities and obtain the maximum value of λ satisfying the constraints of (3).

4. AN ILLUSTRATIVE EXAMPLE

Considering the following numerical example which is adapted from (Radhakrishnan & Anukokila, 2014).

$$\min Z_p(\mathbf{x}) = \frac{\left(\sum_{i=1}^2 \sum_{j=1}^2 \sum_{k=1}^2 c_{ijk}^p \cdot x_{ijk} \right) + c_0^p}{\left(\sum_{i=1}^2 \sum_{j=1}^2 \sum_{k=1}^2 d_{ijk}^p \cdot x_{ijk} \right) + d_0^p} = \frac{N_p(\mathbf{x})}{D_p(\mathbf{x})}, \quad p=1,2 \quad (8)$$

$$\text{s.t.} \quad \begin{aligned} \sum_{j=1}^2 \sum_{k=1}^2 x_{1jk} &\leq 5, & \sum_{j=1}^2 \sum_{k=1}^2 x_{2jk} &\geq 9, \\ \sum_{k=1}^2 \sum_{i=1}^2 x_{i1k} &\geq 7, & \sum_{k=1}^2 \sum_{i=1}^2 x_{i2k} &\leq 5, \\ \sum_{i=1}^2 \sum_{j=1}^2 x_{ij1} &\leq 6, & \sum_{i=1}^2 \sum_{j=1}^2 x_{ij2} &\geq 5, \end{aligned}$$

$$x_{ijk} \geq 0 \quad \forall i, j, k$$

where

$$c_{ij1}^1 = \begin{bmatrix} 5 & 7 \\ 3 & 12 \end{bmatrix} \quad c_{ij2}^1 = \begin{bmatrix} 2 & 1 \\ 8 & 1 \end{bmatrix} \quad c_0^1 = 10 \quad d_{ij1}^1 = \begin{bmatrix} 2 & 3 \\ 4 & 8 \end{bmatrix} \quad d_{ij2}^1 = \begin{bmatrix} 1 & 2 \\ 7 & 1 \end{bmatrix} \quad d_0^1 = 4$$

$$c_{ij1}^2 = \begin{bmatrix} 6 & 5 \\ 6 & 15 \end{bmatrix} \quad c_{ij2}^2 = \begin{bmatrix} 3 & 7 \\ 10 & 3 \end{bmatrix} \quad c_0^2 = 5 \quad d_{ij1}^2 = \begin{bmatrix} 1 & 5 \\ 1 & 9 \end{bmatrix} \quad d_{ij2}^2 = \begin{bmatrix} 2 & 3 \\ 6 & 2 \end{bmatrix} \quad d_0^2 = 6$$

S' is the feasible region of (8). Also, observe that $\emptyset = I_1, \emptyset \neq I_2 = I_3$;
 $\emptyset = J_1, \emptyset \neq J_2 = J_3$; $\emptyset = K_1, \emptyset \neq K_2 = K_3$

The lower and upper bounds for objectives are found as: $U_1 = 1.5$; $L_1 = 0.953$; $U_2 = 2.609$, $L_2 = 1.412$. Then, using (2) and (4), linear and exponential membership functions are defined, respectively, as follows:

$$\begin{aligned} \mu_1(Z_1(\mathbf{x})) &= \frac{1.537 - Z_1(\mathbf{x})}{0.584} \Rightarrow \mu_1(Z_1(\mathbf{x})) = \frac{1.537 \cdot D_1(\mathbf{x}) - N_1(\mathbf{x})}{0.584 \cdot D_1(\mathbf{x})} \\ \mu_2(Z_2(\mathbf{x})) &= \frac{2.609 - Z_2(\mathbf{x})}{1.197} \Rightarrow \mu_2(Z_2(\mathbf{x})) = \frac{2.609 \cdot D_2(\mathbf{x}) - N_2(\mathbf{x})}{1.197 \cdot D_2(\mathbf{x})}, \end{aligned}$$

*A Golden Section Method for the Multi-objective Fractional Solid
Transportation Problem Using the Exponential Membership Function*

$$\begin{aligned}\mu_1(Z_1(\mathbf{x})) &= 1 - \exp\left(\frac{\alpha_1(L_1 - Z_1(\mathbf{x}))}{L_1 - U_1}\right) \Rightarrow \mu_1(Z_1(\mathbf{x})) = 1 - \exp\left(\frac{3 \cdot (Z_1(\mathbf{x}) - 0.953)}{0.584}\right) \\ &\Rightarrow \mu_1(Z_1(\mathbf{x})) = 1 - \exp\left(\frac{3 \cdot (N_1(\mathbf{x}) - 0.953 \cdot D_1(\mathbf{x}))}{0.584 \cdot D_1(\mathbf{x})}\right) \\ \mu_2(Z_2(\mathbf{x})) &= 1 - \exp\left(\frac{\alpha_2(L_2 - Z_2(\mathbf{x}))}{L_2 - U_2}\right) \Rightarrow \mu_2(Z_2(\mathbf{x})) = 1 - \exp\left(\frac{3 \cdot (Z_2(\mathbf{x}) - 1.412)}{1.197}\right) \\ &\Rightarrow \mu_2(Z_2(\mathbf{x})) = 1 - \exp\left(\frac{3 \cdot (N_2(\mathbf{x}) - 1.412 \cdot D_2(\mathbf{x}))}{1.197 \cdot D_2(\mathbf{x})}\right).\end{aligned}$$

Then, the nonlinear problems obtained using the form (3) can be rewritten as:

$$\begin{aligned}\max \lambda & \tag{9} \\ \text{s.t.} \quad & 1.537 \cdot D_1(\mathbf{x}) - N_1(\mathbf{x}) \geq 0.584 \cdot \bar{\lambda} \cdot D_1(\mathbf{x}) \\ & 2.609 \cdot D_2(\mathbf{x}) - N_2(\mathbf{x}) \geq 1.197 \cdot \bar{\lambda} \cdot D_2(\mathbf{x}) \\ & \mathbf{x} \in S'\end{aligned}$$

and

$$\begin{aligned}\max \lambda & \tag{10} \\ \text{s.t.} \quad & N_1(\mathbf{x}) \leq (1.537 + 0.19467 \cdot \ln(1 - \bar{\lambda})) \cdot D_1(\mathbf{x}) \\ & N_2(\mathbf{x}) \leq (2.609 + 0.399 \cdot \ln(1 - \bar{\lambda})) \cdot D_2(\mathbf{x}) \\ & \mathbf{x} \in S',\end{aligned}$$

respectively.

Start applying golden section method proposing for solving (8).

Step 1: Set $\lambda = \mu_{\min} = 0$, then test whether an admissible set satisfying the constraints of (9) exists or not solving linear inequalities. Solving (9) problem, $\mathbf{x}^{(0)} = (0, 0, 0, 0, 0, 9, 0, 0)$ is found. That is, an admissible $\phi \neq S'$ set exists.

Step 2: Set $\lambda = \mu_{\min} + 1$, then test whether an admissible set satisfying the constraints of (9) exists or not solving linear inequalities. An admissible set does not exist. That is, $S' = \emptyset$.

Step 3: For the onset value of $\lambda_1 = \mu_{\min} + \frac{\sqrt{5}-1}{2} = 0 + 0.61803 = 0.61803$, the problem (9) is solved again. And $\mathbf{x}^{(1)} = (0, 0, 0, 0, 0, 9, 0, 0)$ is obtained. That is, an admissible $\emptyset \neq S'$ set exists.

For the initial value of $\lambda_2 = \lambda_1 + \frac{\sqrt{5}-1}{2^2} = 0.92705$, by solving (9), an admissible set cannot be found. ($S' = \emptyset$). Since there is no admissible set of

S' , $\lambda_3 = \lambda_2 - \frac{\sqrt{5}-1}{2^3} \Rightarrow \lambda_3 = 0.77254$ is updated from (7).

Continuing in this way, the sixth iteration, the solution is $\mathbf{x}^{(6)} = (0, 0, 0, 5, 1.973, 22.138, 0, 0)$ solution. Because the same point is found at the end of two consecutive iterations, that is, the value cannot be updated after that, the iteration ends and $\lambda^* = 0.72425$ is found. The corresponding $\mu_1 = 0.71460$ and $\mu_2 = 0.71$ membership function values for this point are obtained.

As all steps of the algorithm are repeated for problem (10), the solutions are also obtained in this way. Also, the results of models corresponding to linear and exponential membership functions are presented in Table 1.

In the proposed method, when the linear one is used, both objective functions have the same satisfaction degree. However, when the exponential one is used, the objectives Z_1 and Z_2 have higher than degree of satisfaction compared to the linear one. Also, the satisfaction degree of Z_2 objective function is better than that of Z_1 . Moreover, the satisfaction degree of Z_2 objective function is better than that of Z_1 . Each of the solutions obtained by using both membership functions is pareto-optimal. However, average satisfaction values of exponential and linear membership

*A Golden Section Method for the Multi-objective Fractional Solid
Transportation Problem Using the Exponential Membership Function*

functions are 0.7252 and 0.7123, respectively. That is, the first membership function has achieved a higher degree of satisfaction.

Table 1. The comparison of membership functions.

Solution	Linear		Exponential	
$\mathbf{x}^{(0)} = (0,0,0,0,0,9,0,0)$	$\mu_1 = 0.53616$	$\mu_2 = 0.86$	$\mu_1 = 0.53616$	$\mu_2 = 0.86$
$\mathbf{x}^{(1)} = (0,0,0,0,0,22.778,0,0)$	$\mu_1 = 0.61803$	$\mu_2 = 0.82$		
$\mathbf{x}^{(4)} = (0,0,0,0,4.805,22.156,0,0)$	$\mu_1 = 0.69528$	$\mu_2 = 0.70$		
$\mathbf{x}^{(6)} = (0,0,0,5,1.973,22.138,0,0)$	$\mu_1 = 0.71460$	$\mu_2 = 0.71$		
$\mathbf{x}^{(1)} = \mathbf{x}^{(3)} = (0,0,0,0,0,9,0,0)$			$\mu_1 = 0.53616$	$\mu_2 = 0.86$
$\mathbf{x}^{(4)} = (0,0,0,0,0,30.322,0,0)$			$\mu_1 = 0.63192$	$\mu_2 = 0.81$
$\mathbf{x}^{(6)} = (0,0,0,0,3.561,11.669,0,0)$			$\mu_1 = 0.677$	$\mu_2 = 0.68$
$\mathbf{x}^{(7)} = (0,0,0,0,4.736,19.522,0,5)$			$\mu_1 = 0.70328$	$\mu_2 = 0.79$
$\mathbf{x}^{(9)} = (0,0,0,0,780,6,34.298,0,4.22)$			$\mu_1 = 0.70995$	$\mu_2 = 0.71$
$\mathbf{x}^{(10)} = (0,0,0,5,1.078,14.540,0,0)$			$\mu_1 = 0.72031$	$\mu_2 = 0.73$

5. CONCLUSION

This paper presents an iterative method to solve this MFSTP with mixed constraints. In proposed solution procedure, Firstly linear and exponential membership functions for all objectives has been defined and then obtained nonlinear problem using Zimmermann's minimum operator. Secondly, this nonlinear problems have been convert into a linear inequality problem by means of golden section method. This transformation enabled mathematically nonlinear problem to be solved easily. Also, a comparison is provided for the solutions of linear and exponential membership functions. The reason for choosing the exponential membership function is that it is versatile and generates better solutions than the linear one. In other words, since the solution obtained using the exponential one provides the highest level of satisfaction among the objectives. Therefore, a more qualified solution is presented to the decision-maker. As a result, it can be concluded that the use of the exponential membership function can generate solutions that fulfill the decision-maker's expectations at a better degree.

*A Golden Section Method for the Multi-objective Fractional Solid
Transportation Problem Using the Exponential Membership Function*

ACKNOWLEDGEMENT

This research received no specific grant from any funding agency in the public, commercial, or not-for-profit sectors.

CONFLICT OF INTEREST STATEMENT

The authors declare no conflict of interest.

REFERENCES

- Ammar, E. E., and Khalifa, H. A. (2014). "Study on multi-objective solid transportation problem with fuzzy numbers". *European Journal of Scientific Research*, Vol. 125, No. 1, pp. 7-19.
- Anitha Kumari, T., Venkateswarlu, B., and Akilbasha, A. (2021). "Optimizing a fully rough interval integer solid transportation problems". *Journal of Intelligent and Fuzzy Systems*, Vol. 41, Issue 1, pp. 2429–2439.
- Anuradha, D., Jayalakshmi, M., Deepa, G., and Sujatha, V. (2019). "Solution of multi-objective solid transportation problem in fuzzy approach". In *AIP Conference Proceedings*, Vol. 2177, Issue 1.
- Basu, M., and Acharya, D. P. (2002). "On quadratic fractional generalized solid BI-criterion transportation problem". *Journal of Applied Mathematics and Computing*, Vol. 10, Issue 1–2, pp.131–143.
- Bit, A. K., Biswal, M. P., and Alam, S. S. (1993). "Fuzzy programming approach to multiobjective solid transportation problem". *Fuzzy Sets and Systems*, Vol. 57, Issue 2, pp. 183-194.
- Cadenas J. M., and Jimenez, F. (1994). "A genetic algorithm for the multi-objective solid transportation problem: A fuzzy approach". In *Proceedings for the Dedicated Conferences on Mechatronics and Supercomputing Applications in the Transportation Industries*, Aachen, Germany, pp. 327–334.
- Cui, Q., and Sheng, Y. (2013). "Uncertain Programming Model for Solid Transportation Problem". *International Information Institute*, 15, pp. 342-348.
- Dalman, H. (2016). "A fuzzy approach for interval multiobjective solid transportation problem". *New Trends in Mathematical Sciences*, Vol. 4, No. 4, pp. 114-127.

*A Golden Section Method for the Multi-objective Fractional Solid
Transportation Problem Using the Exponential Membership Function*

Gen, M., Ida, K., Li, Y., and Kubota E. (1995). "Solving bicriteria solid transportation problem with fuzzy numbers by a genetic algorithm". *Computers and Industrial Engineering*, Vol. 29, Issue 1-4, pp. 537-541.

Ida, K., Gen, M., and Li, Y. (1995). "Solving multicriteria solid transportation problem with fuzzy numbers by genetic algorithms". In *European Congress on Intelligent Techniques and Soft Computing (EUFIT' 95)*, Aachen, Germany, pp. 434- 441.

Jana, S. H., and Jana, B. (2020). "Application of fuzzy programming techniques to solve solid transportation problem with additional constraints". *Operations Research and Decisions*, Vol. 30, No. 1, pp. 67-84.

Jimenez, F., and Verdegay, J. L. (1998). "Uncertain solid transportation problems". *Fuzzy sets and Systems*, Vol. 100, Issues 1-3, pp. 45-57.

Jimenez, F., and Verdegay, L. J. (1999). "Solving fuzzy solid transportation problem by an evolutionary algorithm based on parametric approach". *European Journal of Operational Research*, Vol. 117, Issue 3, pp. 485- 510.

Khalifa, H. A. E. (2019). "Fuzzy Compromise Approach for Solving Interval-Valued Fractional Multi-Objective Multi-Product Solid Transportation Problems". *Journal of System Management*, Issue 2, pp. 1–20.

Khalifa, H. A., and Al-Shabi, M. (2018). "Utilizing of Fractional Programming for Multi-Objective Multi-Item Solid Transportation Problems in Fuzzy Environment". *International Journal of Current Research*, Vol.10, Issue 11, pp.75024-75035.

Khalifa, H. A.W., Kumar P., and Alharbi, M. G. (2021). "On characterizing solution for multi-objective fractional two-stage solid transportation problem under fuzzy environment". *Journal of Intelligent Systems*, Vol.30, Issue 1, pp.620-635.

Kumar, G. N., and Dutta, D. (2015). "Solving multi- objective fuzzy solid transportation problem based on expected value and the goal programming approach". *IOSR Journal of Mathematics*, Vol. 11, Issue 2, pp. 88- 96.

Li, Y., Ida, K., and Gen, M. (1997). "Improved genetic algorithm for solving multiobjective solid transportation problem with fuzzy numbers". *Japan Society for Fuzzy Theory and Systems*, Vol. 9, No. 2, pp. 239-250

Nagarajan, A., Jeyaraman, K., and Krishna Prabha, S. (2014). "Multi-objective solid transportation problem with interval cost in source and demand parameters". *International Journal of Computer & Organization Trends*, Vol. 4, Issue 3, pp. 24-32.

Ojha, A., Das, B., Mondal, S., and Maiti, M. (2009). "An entropy based solid transportation problem for general fuzzy costs and time with fuzzy equality". *Mathematical Computation Model*, Vol. 50, No. 1-2, pp. 166-178.

Ojha, A., Mondal, S. K., & Maiti, M. (2014). A solid transportation problem with partial nonlinear transportation cost. *Journal of Applied and Computational Mathematics*, 3(150), 1-6.

Pandian, P., and Anuradha, D. (2010). "A new approach for solving solid transportation problems". *Applied Mathematical Sciences*, Vol. 4, No. 69-72, pp. 3603-3610.

Radhakrishnan, B., and Anukokila, P. (2014). "Fractional Goal Programming for Fuzzy Solid Transportation Problem with Interval Cost". *Fuzzy Information and Engineering*, Vol. 6, Issue 3, pp. 359–377.

Sakawa M., and Yano, H. (1988). "An interactive fuzzy satisficing method for multiobjective linear fractional programming problems". *Fuzzy Sets and Systems*, Vol. 28, Issue 2, pp. 129-144.

A Golden Section Method for the Multi-objective Fractional Solid Transportation Problem Using the Exponential Membership Function

Sakawa, M., and Yumine, T. (1983). “Interactive fuzzy decision-making for multiobjective linear fractional programming problems”. *Large Scale Systems*, 5, pp. 105-113.

Singh, S., Pradhan, A., and Biswal, M. P. (2019). “Multi-objective solid transportation problem under stochastic environment”. *Sadhana - Academy Proceedings in Engineering Sciences*, 44(5).

Sobana, V. E., and Anuradha, D. (2018). “Solution of Solid Transportation Problem in Fuzzy Approach”. *International Journal of Pure and Applied Mathematics*, Vol. 119, No. 9, pp. 313–321.

Tao, Z., and Xu, J. (2012). “A class of rough multiple objective programming and its application to solid transportation problem”. *Information Sciences*, Vol. 188, pp. 215–235.

JOURNAL OF NAVAL SCIENCES AND ENGINEERING (JNSE) PUBLISHING RULES

Submission of Papers: Manuscripts which are submitted to the journal should not be published elsewhere or sent to be published. Authors are (preferably) requested to submit an electronic copy of their original works to the given "System Address" or one hard copy to the address and a soft-copy to the "E-mail Address" which have been given below. It is necessary for the authors to submit their manuscripts together with the "Copyright Release Form". "Copyright Release Form" can be downloaded from the "Copyright Page" of JNSE's Web Page. Authors are requested to obtain the relevant documents for their studies that require "Ethics Committee Approval and/or Legal/Special Permission" and submit these approval documents to the system together with their study.

System Address:

<https://dergipark.org.tr/pub/jnse>

Address:

Doç.Dr. Ertan YAKICI
Milli Savunma Üniversitesi
Barbaros Deniz Bilimleri ve Mühendisliği Enstitüsü
Deniz Harp Okulu Yerleşkesi
34942 Tuzla/Istanbul/Türkiye

E-mail: jnse@dho.msu.edu.tr

Types of Contributions: The journal publishes original papers, review articles, technical notes, book reviews, letters to the editor, extended reports of conferences and meetings.

Manuscript Evaluation Process: The Peer Review Step:

- The content and layout format of manuscript are examined and the originality of study is checked by iThenticate Software Programme.
- The language and correlation of the English abstract with Turkish abstract are checked.
- Manuscript which has a similarity index above 40% is rejected. The author is informed about the manuscript which has a similarity index between 20% and 40% (must not contain more than 4% from a single source), which is not appropriate for the writing rules of JNSE or needs correction in English and Turkish abstracts and the author is requested to revise the manuscript within "two weeks". Otherwise, the article is considered as a retracted manuscript.

Our journal uses **double-blind** review, which means that both the reviewer and author identities are concealed from the reviewers, and vice versa, throughout the review process. So, the uploaded manuscript does not contain the name, address and affiliation of author(s). The manuscript evaluation steps are as follows:

- Editor is assigned by the Editor-in-Chief.
- The relevant reviewers are assigned by the Editors.
- As a result of the reviewer's evaluation, the manuscript may be rejected, accepted or a correction for the manuscript may be requested.
- If the negative feedback is given by major number of the reviewers the process is terminated and the article is rejected.
- If major/minor revisions are required for the manuscript, the author has to do this revision according to the reviewers' comments in "three weeks".
- If the revision is accepted by the reviewers, the article is accepted.

The Workflow Diagram for the evaluation process can be accessed from the web page of the journal.

The articles submitted to JNSE to be published are free of article submission, processing and publication charges.

The accepted articles are published **free-of-charge** as online from the journal website and printed.

DENİZ BİLİMLERİ VE MÜHENDİSLİĞİ DERGİSİ (DBMD) YAYIN KURALLARI

Yazıların Gönderilmesi: Dergiye gönderilen makaleler başka bir yerde yayımlanmamış ya da yayımlanmak üzere gönderilmemiş olmalıdır. Yayımlanması istenilen yazılar (tercihen) aşağıda verilen “Sistem Adresi”nden yüklenmeli veya aşağıdaki adrese bir kopya kâğıda basılı olarak ve aynı zamanda “E-mail Adresi”ne dijital olarak gönderilmelidir. Dergimize makale gönderen yazarların makaleleriyle birlikte “Yayın Hakkı Devir Formu”nu da göndermeleri gerekmektedir. “Yayın Hakkı Devir Formu”na DBMD Web Sayfasındaki “Telif Hakkı” sayfasından erişilebilmektedir. Yazarların “Etik Kurul İzni ve/veya Yasal/Özel İzin” gerektiren çalışmaları için ilgili izin belgelerini temin etmesi ve bu izin belgelerini çalışmalarıyla birlikte sisteme yüklemeleri gerekmektedir.

Sistem Adresi:

<https://dergipark.org.tr/pub/jnse>

Adres:

Doç.Dr. Ertan YAKICI
Barbaros Deniz Bilimleri ve Mühendisliği Enstitüsü
Deniz Harp Okulu Yerleşkesi
34942 Tuzla/ İstanbul/Türkiye

E-mail: jnse@dho.msu.edu.tr

Yazı Türleri: Dergide; orijinal yazılar, derlemeler, teknik notlar, kitap incelemeleri, editöre mektuplar ile konferans ve toplantıların genişletilmiş raporları yayımlanır.

Yazıların Değerlendirilme Süreci: Makalenin Ön Kontrol Süreci:

- Makalenin içeriği ve yazım formatı incelenir ve iThenticate Programı ile benzerlik taraması yapılır.
- Makalenin İngilizce özetinin, Türkçe öz ile uygunluğu ve yazım dili kontrol edilir.
- Benzerlik oranı %40’ın üzerinde olan makale reddedilir. Benzerlik oranı %20 ile %40 arasında olan (tek bir kaynakla benzerlik %5’ten fazla olmamalıdır), yazım formatına uymayan ya da İngilizce ve Türkçe özetinde düzeltme gereken makale yazara bildirilir ve “iki hafta” içerisinde makalenin düzeltilmesi istenir. Aksi takdirde makale geri çekilmiş kabul edilir.

Dergimiz, makale değerlendirme sürecinde **çift-kör** hakemlik sistemini kullanmaktadır. Buna göre değerlendirme sürecinde hakem ve yazarlar birbirlerinin bilgilerini görememektedir. Bu nedenle, yüklenen ön yükleme formatında yazar(lar)ın isim, adres ve bağlı olduğu kuruluş(lar) yer almamaktadır. Makale değerlendirme sürecindeki adımlar ise aşağıdaki gibidir;

- Baş editör tarafından makaleye Editör atanır.
- Editörler makale için hakemleri atar.
- Hakem değerlendirmesi sonucunda makale reddedilebilir, kabul edilebilir veya makalenin düzeltilmesi istenebilir.
- Hakem görüşlerinin çoğunluğu doğrultusunda makale reddedilmiş ise süreç sonlandırılır ve makale reddedilir.
- Makale için majör / minör düzeltme istenirse hakem görüşleri doğrultusunda yazarın gerekli düzeltmeleri en geç “üç hafta” içerisinde yapması istenir.
- Revize edilmiş makale kabul alırsa düzenleme aşamasına geçilir.

Değerlendirme sürecine ilişkin Akış Şemasına, derginin web sayfasından erişilebilir.

DBMD’ye yayımlanmak üzere gönderilen makaleler; makale gönderim, işlem ve yayın ücretinden muafır.

Kabul edilen makaleler, **ücretsiz** olarak basılı şekilde ve dergi web sayfasından çevrimiçi (online) olarak yayımlanmaktadır.

JOURNAL OF NAVAL SCIENCES AND ENGINEERING (JNSE) WRITING RULES

General: Manuscripts must be prepared in MS Word, single-spaced with justify. Font: Times New Roman, 12 points. Margins: left 4,5 cm- right 3,5 cm, top 5 cm- bottom 7 cm, header 3,25 cm- footer 6 cm, gutter 0. Paper type: A4. Page numbers should be on the middle of bottom of page with -1-, -2-, -3- etc. format. Using footnotes is not allowed.

Ethics Committee Approval and/or Legal/Special Permission: The articles must state whether an ethical committee approval and/or legal/special permission is required or not. If these approvals are required, then it should be clearly presented from which institution, on what date and with which decision or number these approvals are obtained.

Body of Text: Follow this order when typing manuscripts: Title, Authors, Abstract, Keywords, Title (Turkish), Abstract (Turkish), Keywords (Turkish), Main Text, Appendix (if any), References.

Title: Title should reflect objectives of the paper clearly, be easily understandable and not exceed 15 words.

Abstracts: Each paper should have an abstract with 100-200 words and have a structured form, i.e. standard structure of an article (background, purpose, material and methods used, results, conclusion).

Paper Length: The manuscript should be minimum 2000 words or 5 pages, maximum 7000 words or 25 pages including references.

Keywords: Author must provide some keywords (between 3 and 5) that will be used to classify the paper.

Unit: International System of Unit (Système Internationale d'Unités; SI) (<https://www.britannica.com/science/International-System-of-Units>) should be used for all scientific and laboratory data.

References: References should be given according to the APA standard as effective from November, 2020 issue.

Abbreviations and Acronyms: Standard abbreviations and acronyms should be used for each related discipline. Acronyms should be identified at the first occurrence in the text. Abbreviations and acronyms may also be attached to main text as an appendix.

Equations and Formulas: Equations and formulas should be numbered consecutively. These numbers must be shown within parentheses being aligned to the right. In the text, equations and formulas should be referred with their numbers given in parentheses. Comprehensive formulas, not appropriate to be written in the texts, should be prepared in figures.

Figures and Tables: Figures and tables should be numbered consecutively. In the text referring to figures and tables should be made by typing "Figure 1." or "Table 1." etc. A suitable title should be assigned to each of them.

DENİZ BİLİMLERİ VE MÜHENDİSLİĞİ DERGİSİ (DBMD)

YAZIM KURALLARI

Genel Bilgiler: Yazılar; Microsoft Word'de tek satır aralığı ve iki yana yaslanarak hazırlanmalıdır. Yazı tipi: Times New Roman, 12 punto. Kenar boşlukları: sol 4,5 cm- sağ 3,5 cm- üst 5 cm- alt 7 cm- üst bilgi 3,25 cm- alt bilgi 6 cm, oluk 0. Kâğıt ölçüsü: A4. Sayfa numaraları sayfanın alt ortasında -1-, -2-, -3- vb. şeklinde yer almalıdır. Dipnot kullanılmamalıdır.

Etik Kurul İzni ve/veya Yasal/Özel İzin: Makalelerde etik kurul izni ve/veya yasal/özel izin alınmasının gerekip gerekmediği belirtilmiş olmalıdır. Eğer bu izinlerin alınması gerekli ise, izinlerin hangi kurumdan, hangi tarihte ve hangi karar veya sayı numarası ile alındığı açıkça sunulmalıdır.

Yazı Yapısı: Yazı şu sırada hazırlanmalıdır: Başlık, Yazarlar, Özet, Anahtar Kelimeler, Başlık (Türkçe), Özet (Türkçe), Anahtar Kelimeler (Türkçe), Ana Metin, Ek (varsa), Referanslar.

Başlık: Başlık; açık, net, anlaşılır olmalı ve 15 kelimeyi geçmemelidir.

Öz (Abstract): Yazı, 100-200 kelimelik, arka plan, amaç, yöntem, bulgular ve sonuçtan oluşan yapılandırılmış bir özeti içermelidir.

Sayfa Sayısı: Dergiye gönderilecek yazıların boyutu, kaynakça dâhil asgari 2000 kelime veya 5 sayfa, azami 7000 kelime veya 25 sayfa arasında olmalıdır.

Anahtar Kelimeler: Yazıyı sınıflandırmaya yarayacak, anahtar görevi yapan 3-5 kelime yer almalıdır.

Birimler: Yazının uluslararası alanlarda da kolay izlenebilir ve anlaşılabilir olması için Uluslararası Birim Sistemine (<https://www.britannica.com/science/International-System-of-Units>) uygun olarak hazırlanması gerekir.

Referans: Referanslar Kasım, 2020 sayısından itibaren geçerli olmak üzere APA standardına göre verilmelidir.

Notasyon ve Kısaltmalar: İlgili bilim alanının standart notasyon ve kısaltmaları kullanılmalı, yeni notasyonlar ise metin içinde ilk geçtiği yerde tanımlanmalıdır. Gerekli durumlarda, notasyon ve kısaltmalar ek olarak konulabilir.

Denklem ve Formüller: Denklem ve formüller ardışık olarak numaralandırılmalı ve bu numaralar sağa dayalı parantez içinde yazılmalıdır. Metin içinde denklem ve formüllere parantez içinde yazılan numaraları ile atıfta bulunulmalıdır. Metin arasında verilmesi uygun olmayan kapsamlı formüller şekil olarak hazırlanmalıdır.

Şekiller ve Tablolar: Şekiller ve tablolar, ardışık olarak numaralandırılmalıdır. Bunlara metin içinde "Şekil 1." veya "Tablo 1." şeklinde atıfta bulunulmalıdır. Her bir şekil ve tablo için uygun bir başlık kullanılmalıdır.

Ethical Principles and Publication Policy

Journal of Naval Sciences and Engineering (hereafter JNSE) is a peer reviewed, international, inter-disciplinary journal in science and technology, which is published semi-annually in November and April since 2003. JNSE is committed to provide a platform where highest standards of publication ethics are the key aspect of the editorial and peer-review processes.

The editorial process for a manuscript to the JNSE consists of a double-blind review, which means that both the reviewer and author identities are concealed from the reviewers, and vice versa, throughout the review process. If the manuscript is accepted in the review stage of the Editorial Process then, the submission goes through the editing stage, which consists of the processes of copyediting, language control, reference control, layout and proofreading. Reviewed articles are treated confidentially in JNSE.

Papers submitted to JNSE are screened for plagiarism with the iThenticate plagiarism detection tool. In case that the editors become aware of alleged or proven scientific misconduct, they can take the necessary steps. The editors have the right to retract an article whether submitted to JNSE or published in JNSE.

Following the completion of the editing stage, the manuscript is then scheduled for publication in an issue of the JNSE. The articles which are submitted to JNSE to be published are free of article submission, processing and publication charges. The accepted articles are published free-of-charge as online from the journal website and printed. The articles that are accepted to appear in the journal are made freely available to the public via the journal's website. The journal is also being printed by National Defence University Turkish Naval Academy Press on demand. The printed version can be accessed free of charge from the libraries of the Turkish Universities.

JNSE has editors and an editorial board which consists of academic members from at least five different universities. JNSE has an open access policy which means that all contents are freely available without charge to the user or his/her institution. Users are allowed to read, download, copy, distribute, print, search, or link to the full texts of the articles, or use them for any other lawful research purposes.

Publication ethics of the JNSE are mainly based on the guidelines and recommendations which are published by the Committee on Publication Ethics (COPE), World Federation of Engineering Organizations (WFEO), Council of Science Editors (CSE) and Elsevier's Publishing Ethics for Editors statements.

The duties and responsibilities of all parties in the publishing process including editors, authors and others are defined below.

The Responsibilities of the Authors:

- Authors are responsible for the scientific, contextual, and linguistic aspects of the articles which are published in the journal. The views expressed or implied in this publication, unless otherwise noted, should not be interpreted as official positions of the Institution.
- Authors should follow the "Author Guidelines" in JNSE's web page on DergiPark.
- Authors should conduct their researches in an ethical and responsible manner and follow all relevant legislation.
- Authors should take collective responsibility for their work and for the content of their publications.
- Authors should check their publications carefully at all stages to ensure that methods and findings are reported accurately.
- Authors must represent the work of others accurately in citations, quotations and references.
- Authors should carefully check calculations, data presentations, typescripts/submissions and proofs.
- Authors should present their conclusions and results honestly and without fabrication, falsification or inappropriate data manipulation. Research images should not be modified in a misleading way.
- Authors should describe their methods to present their findings clearly and unambiguously.
- Authors accept that the publisher of JNSE holds and retains the copyright of the published articles.
- Authors are responsible to obtain permission to include images, figures, etc. to appear in the article.

- In multi-authored publications -unless otherwise stated- author rankings are made according to their contributions.
- Authors should alert the editor promptly if they discover an error in any submitted.
- Authors should follow the publication requirements regarding that the submitted work is original and has not been published elsewhere in any language.
- Authors should work with the editor or publisher to correct their work promptly if errors are discovered after publication.
- If the work involves chemicals, procedures or equipment that have any unusual hazards inherent in their use, the authors must clearly identify these in the manuscript.
- If the work involves the use of animals or human participants, the authors should ensure that all procedures were performed in compliance with relevant laws and institutional guidelines and that the appropriate institutional committee(s) has approved them; the manuscript should contain a statement to this effect.
- Authors should also include a statement in the manuscript that informed consent was obtained for experimentation with human participants. Because the privacy rights of human participants must always be preserved. It is important that authors have an explicit statement explaining that informed consent has been obtained from human participants and the participants' rights have been observed.
- Authors have the responsibility of responding to the reviewers' comments promptly and cooperatively, in a point-by-point manner.

The Responsibilities of the Reviewers:

- Peer review process has two fundamental purposes as follow: The first purpose is to decide whether the relevant article can be published in JNSE or not and the second purpose is to contribute to the improvement of the weaknesses of the related article before the publication.
- The peer review process for an article to the JNSE consists of a double-blind review, which means that both the reviewer and author identities are concealed from the reviewers, and vice versa, throughout the review process. Reviewed articles are treated confidentially in JNSE.
- Reviewers must respect the confidentiality of peer review process.
- Reviewers must refrain from using the knowledge that they have obtained during the peer review process for their own or others' interests.
- Reviewers should definitely be in contact with the JNSE if they suspect about the identity of the author(s) during the review process and if they think that this knowledge may raise potential competition or conflict of interest.
- Reviewers should notify the JNSE in case of any suspicion regarding the potential competition or conflict of interest during the review process.
- Reviewers should accept to review the studies in which they have the required expertise to conduct an appropriate appraisal, they can comply with the confidentiality of the double-blind review system and that they can keep the details about the peer review process in confidential.
- Reviewers should be in contact with the JNSE in order to demand some missing documents, following the examination of the article, supplementary files and ancillary materials.
- Reviewers should act with the awareness that they are the most basic determinants of the academic quality of the articles to be published in the journal and they should review the article with the responsibility to increase academic quality.
- Reviewers should be in contact with the JNSE editors if they detect any irregularities with respect to the Ethical Principles and Publication Policy.
- Reviewers should review the articles within the time that has been allowed. If they can not review the article within a reasonable time-frame, then they should notify the journal as soon as possible.
- Reviewers should report their opinions and suggestions in terms of acceptance / revision / rejection for the manuscript in the peer review process through the Referee Review Form which is provided by JNSE.
- In case of rejection, reviewers should demonstrate the deficient and defective issues about the manuscript in a clear and concrete manner in the provided Referee Review Form.
- Review reports should be prepared and submitted in accordance with the format and content of the Referee Review Form which is provided by JNSE.
- Review reports should be fair, objective, original and prudent manner.
- Review reports should contain constructive criticism and suggestions about the relevant article.

The Responsibilities of the Editors:

-Editors are responsible of enhancing the quality of the journal and supporting the authors in their effort to produce high quality research. Under no conditions do they allow plagiarism or scientific misconduct.

-Editors ensure that all submissions go through a double-blind review and other editorial procedures. All submissions are subject to a double-blind peer-review process and an editorial decision based on objective judgment.

-Each submission is assessed by the editor for suitability in the JNSE and then, sent to the at least two expert reviewers.

-Editors are responsible for seeking reviewers who do not have conflict of interest with the authors. A double-blind review assists the editor in making editorial decisions.

-Editors ensure that all the submitted studies have passed initial screening, plagiarism check, review and editing. In case the editors become aware of alleged or proven scientific misconduct, they can take the necessary steps. The editors have the right to retract an article. The editors are willing to publish errata, retractions or apologies when needed.

Etik İlkeler ve Yayın Politikası

Deniz Bilimleri ve Mühendisliği Dergisi (Bundan sonra DBMD olarak anılacaktır.); uluslararası düzeyde, hakemli, çok disiplinli, Nisan ve Kasım aylarında olmak üzere 2003 yılından bu yana yılda iki kez yayınlanan, bilim ve teknoloji dergisidir. DBMD yayın etiğinde en yüksek standartların, editöryal ve hakemlik süreçlerinin kilit unsuru olarak değerlendirildiği bir platform sunmayı taahhüt etmektedir.

DBMD'ne gönderilen her bir makale için değerlendirme sürecinde çift-kör hakemlik sistemi uygulanmaktadır. Buna göre, değerlendirme süreci boyunca hakem ve yazarlar birbirlerinin bilgilerini görememektedir. Dergiye gönderilen çalışmaların yazar-hakem ve hakem-yazar açısından süreçlerinde gizlilik esastır. DBMD'ne gönderilen makalelerin değerlendirme sürecindeki inceleme aşamasında kabul edilmeleri halinde, ilgili makaleler için düzenleme aşamasına geçilmektedir. Düzenleme aşamasında, ilgili makaleler yazım formatı ve dilbilgisel yönlerden incelenir. Makalelerin sayfalar üzerindeki biçimi ve yerleşimleri kontrol edilip düzenlenir. Ayrıca referans kontrolü yapılır. DBMD'nde kontrol edilen ve düzenlenen makaleler gizli tutulmaktadır.

DBMD'ne gönderilen makaleler, iThenticate intihal tespit programı aracılığıyla bilimsel çalıntı konusunda kontrol edilir. Editörler, iddia edilen veya kanıtlanmış bir bilimsel kötü kullanımdan ya da usulsüzlükten haberdar olurlarsa bu konuda gerekli adımları atabilirler. Bu anlamda, Editörler gerekli durumlarda DBMD'ne gönderilen ya da DBMD'nde yayınlanmış makaleleri geri çekme hakkına sahiptir.

Düzenleme aşamasının başarılı olarak sonuçlanmasını takiben, ilgili makaleler DBMD'nin bir sayısında yayınlanmak üzere saklı tutulur ve kayıt altına alınır. DBMD'ne yayınlanmak üzere gönderilen makaleler; yazılı materyal gönderme, işleme ve yayınlama süreçlerindeki tüm ücretlerden muaf tutulmaktadır. DBMD'nde yayınlanmak üzere kabul edilen makaleler, derginin internet sitesinden çevrimiçi olarak ücretsiz bir şekilde yayınlanır ve basılır. Dergide yayınlanması kabul edilen çalışmalar, derginin web sitesinden açık erişim ile erişilebilir kılınmıştır. Dergi ayrıca, Milli Savunma Üniversitesi, Deniz Harp Okulu Basımevi tarafından basılmaktadır. Derginin basılı haline Üniversite kütüphanelerinden erişilebilmektedir.

DBMD; editörü ve en az beş değişik üniversitenin öğretim üyelerinden oluşmuş danışman grubu ile açık erişim politikasını benimsemektedir. Buna göre, tüm içerikler ücretsiz olarak kullanıcılar veya kurumlar için ulaşılabilir. Kullanıcıların DBMD bünyesindeki makalelerin tam metinlerini okuma, indirme, kopyalama, dağıtma, yazdırma, arama veya bunlara bağlantı verme ve diğer yasal araştırma amaçları için kullanma hakları saklı tutulmaktadır.

DBMD'nin yayın etiği, temel olarak Yayın Etiği Komitesi (COPE), Dünya Mühendislik Kuruluşları Federasyonu (WFEO), Bilim Kurulu Editörleri (CSE) ve Elsevier'in Editörler için Yayın Etiği açıklamaları kapsamında yayınlanmış yönergelere ve önerilere dayanmaktadır.

Editörler, yazarlar ve diğer taraflar da dâhil edilebilecek şekilde yayın sürecindeki görev ve sorumluluklar aşağıdaki gibi tanımlanmıştır.

Yazarların Sorumlulukları:

-Yazarlar, dergide yayınlanan makalelerinin bilimsel, bağlamsal ve dilsel yönlerinden sorumlu tutulmaktadır. Dergide ifade edilen veya ima edilen görüşler, aksi belirtilmediği sürece, Enstitünün resmi görüşü olarak yorumlanamaz ve yansıtılamaz.

-Yazarlar çalışmalarında, DBMD'nin DergiPark internet sayfasında yer alan "Yazım Kuralları"na dikkate almalıdır.

-Yazarlar araştırmalarını etik ve sorumlu bir şekilde yürütmeli ve ilgili tüm mevzuatları takip etmelidir.

-Yazarlar çalışmalarını ve yayınlarının içeriği için ortak sorumluluk almalıdır.

-Yazarlar, yöntemlerin ve bulguların doğru bir şekilde raporlandığından emin olmak için yayınlarını her aşamada dikkatlice kontrol etmelidir.

-Yazarlar, başkalarına ait çalışmalarını dolaylı alıntı, doğrudan alıntı ve referanslar ile doğru bir şekilde göstermelidir. Yazarlar, makalelerindeki fikirlerin şekillendirilmesinde etkili ya da bilgilendirici olmuş her türlü kaynağa referans vermelidir.

-Yazarlar çalışmalarındaki hesaplamaları, ispatları, veri sunumlarını ve yazı tiplerini dikkatlice kontrol etmelidir.

- Yazarlar çalışmalarının sonuçlarını dürüstçe; uydurma, çarpıtma, tahrifat veya uygunsuz manipülasyona yer vermeden sunmalıdır. Çalışmalardaki görsel kaynaklar yanıltıcı bir şekilde değiştirilmemelidir.
- Yazarlar, çalışmalarındaki bulguları açık ve net bir şekilde sunmak için araştırma yöntemlerini tanımlamalı ve paylaşmalıdır.
- Yazarlar, yayınlanmış makalelerinin telif haklarını DBMD yayıncısına devrettiklerini kabul etmektedir.
- Yazarlar çalışmalarına çeşitli görsel kaynakları, figürleri, şekilleri vb. dahil etmek için gerekli izinleri almakla yükümlüdür. İlgili çalışmada yer alması gereken resim, şekil vb. anlatımı destekleyici materyaller için gerekli kişilerden ya da kurumlardan izin alınması yazarın sorumluluğundadır.
- Çok yazarlı yayınlarda -aksi belirtilmedikçe- yazar sıralamaları sunulan katkılara göre yapılmalıdır.
- Yazarlar gönderdikleri çalışmada herhangi bir hata tespit ederlerse bu konuda derhal editörü uyarmalıdır.
- Yazarlar dergiye gönderdikleri makalelerin başka bir yerde yayımlanmamış ya da yayımlanmak üzere gönderilmemiş olmaları ile ilgili DBMD'nin DergiPark internet sayfasında yer alan "Yayın Kuralları"na dikkate almalıdır.
- Yazarlar, ilgili çalışmaları DBMD'nde yayınlandıktan sonra hata tespit ederlerse bu konuda gerekli düzeltmelerin yapılabilmesi amacıyla derhal editör veya yayıncı ile iletişime geçip onlar ile birlikte çalışmalıdır.
- İlgili çalışmada, doğası gereği kullanımlarında olağandışı tehlikeler barındıran çeşitli kimyasallar veya ekipmanlardan yararlanılmış ise yazarların tüm bunları çalışmasında açıkça belirtmesi ve tanımlaması gerekmektedir.
- İnsanlar ve hayvanların katılımını gerektiren çalışmalar için, yazarlar tüm sürecin ilgili yasalara ve kurumsal yönergelere uygun olarak gerçekleştirildiğinden emin olmalıdır ve ilgili komitelerden etik onay alındığını çalışmalarında açık bir şekilde ifade edip belgelendirmelidir.
- İnsanların katılımını gerektiren çalışmalar için, yazarlar kurumsal etik kurul onayı almakla yükümlüdürler. Yazarlar, katılımcıların süreç ile ilgili olarak bilgilendirildiklerini ve bu anlamda, katılımcılardan gerekli izinlerin alındığını bildirmek ve belgelemek zorundadır. Yazarlar, katılımcıların haklarının gözetildiğini açıklayan açık bir bildirim sunmalıdır. Ayrıca bu süreçte, katılımcıların gizlilik hakları her zaman korunmalıdır.
- Yazarlar, hakemlerin değerlendirmelerini, yorumlarını ve eleştirilerini zamanında ve işbirliği içerisinde dikkate almalıdır ve bu konuda, gerekli güncellemeleri yapmalıdır.

Hakemlerin Sorumlulukları:

- Hakem değerlendirme sürecinin iki temel amacı vardır: İlk amaç, ilgili makalenin DBMD'nde yayınlanıp yayınlanamayacağına karar vermektir ve ikinci amaç, yayından önce ilgili makalenin eksik yönlerinin geliştirilmesine katkıda bulunmaktır.
- DBMD'ne gönderilen her bir makale için değerlendirme sürecinde çift-kör hakemlik sistemi uygulanmaktadır. Buna göre, değerlendirme süreci boyunca hakem ve yazarlar birbirlerinin bilgilerini görememektedir. Dergiye gönderilen çalışmaların yazar-hakem ve hakem-yazar açısından süreçlerinde gizlilik esastır.
- Hakemler, değerlendirme sürecinin gizliliğine saygı göstermelidir.
- Hakemler, değerlendirme sürecinde elde ettikleri bilgileri kendilerinin veya başkalarının çıkarları için kullanmaktan kaçınmalıdır.
- Hakemler, değerlendirme sürecinde yazar(lar)ın kimliğinden şüphe etmeleri ve bu bilginin herhangi bir potansiyel rekabet veya çıkar çatışması yaratacağını düşünmeleri halinde mutlaka DBMD ile iletişime geçmelidir.
- Hakemler, değerlendirme sürecinde şüphe ettikleri potansiyel rekabet veya çıkar çatışması durumlarını DBMD'ne bildirmelidir.
- Hakemler, uygun bir değerlendirme yapabilmek için gereken uzmanlığa sahip oldukları, çift-kör hakemlik sisteminin gizliliğine riayet edebilecekleri ve değerlendirme süreci ile ilgili detayları gizli tutabilecekleri çalışmaların hakemliğini kabul etmelidir.
- Hakemler makaleyi, ek dosyaları ve yardımcı materyalleri incelemelerini takiben bazı eksik belgelere ihtiyaç duymaları halinde bunları talep etmek üzere DBMD ile iletişime geçmelidir.
- Hakemler dergide yayınlanacak makalelerin akademik kalitesinin en temel tespit edicisi olduklarının bilinciyle davranmalı ve akademik kaliteyi artırma sorumluluğuyla inceleme yapmalıdır.
- Hakemler, Etik İlkeler ve Yayın Politikası ile ilgili herhangi bir usulsüzlük tespit etmeleri halinde DBMD editörleri ile irtibata geçmelidir.

- Hakemler, kendilerine tanınan süre içerisinde makaleleri değerlendirmelidir. Şayet uygun bir zaman içerisinde değerlendirme yapamayacaklarsa, bu durumu en kısa zamanda DBMD'ne bildirmelidirler.
- Hakemler, değerlendirme sürecindeki çalışma için kabul etme / yeniden gözden geçirme / reddetme şeklindeki önerilerini DBMD tarafından sağlanan Hakem Değerlendirme Formu aracılığıyla bildirmelidir.
- Sonucu reddetme şeklinde olan değerlendirmeler için hakemler, ilgili çalışmaya dair eksik ve kusurlu hususları Hakem Değerlendirme Formu'nda açık ve somut bir şekilde ortaya koymalıdır.
- Hakem değerlendirme raporlarının, DBMD tarafından sağlanan Hakem Değerlendirme Formu'na uygun biçimde ve içerikte hazırlanması ve gönderilmesi gerekmektedir.
- Hakem değerlendirme raporları adil, objektif, özgün ve ölçülü olmalıdır.
- Hakem değerlendirme raporları, ilgili makale ile ilgili yapıcı eleştiriler ve tavsiyeler içermelidir.

Editörlerin Sorumlulukları:

- Editörler, derginin bilimsel kalitesini arttırmak ve yazarları bilimsel kalitesi yüksek araştırmalar üretmek için desteklemek ile sorumludur. Hiçbir koşulda, intihal ya da bilimsel kötüye kullanıma izin verilmemektedir.
- Editörler, dergiye gönderilen her çalışmanın çift-kör hakemlik sürecine ve diğer editoryal süreçlere tabi olmasını sağlamaktadır. DBMD'ne gönderilen her çalışma, çift-kör hakemlik sürecine ve nesnel değerlendirmeye dayalı editör kararına bağlı tutulmaktadır.
- DBMD'ne gönderilen her bir çalışma, uygunlukları açısından editör tarafından değerlendirilir ve daha sonrasında, incelenmesi ve değerlendirilmesi amacıyla en az iki uzman hakeme gönderilir.
- Editörler, yazarlar ile çıkar çatışması olmayan hakemleri, çalışmayı değerlendirmek üzere atamakla sorumludur. Çift-kör hakemlik süreci, editör için değerlendirme ve düzenleme aşamalarında katkı sağlamaktadır.
- Editörler, DBMD'ne gönderilen tüm çalışmaların ön kontrol, tarama, intihal kontrolü, değerlendirme ve düzenleme aşamalarından geçmesini sağlar. Editörler iddia edilen veya kanıtlanmış bilimsel kötü kullanımdan haberdar olurlarsa makaleyi geri çekebilirler. Editörler, gerekli durumlarda gönderilen çalışmayı düzeltme, geri çekme veya çalışma hakkında özür yayınlama hakkına sahiptir.

CONTENTS / İÇİNDEKİLER

Management Information Systems / Yönetim Bilişim Sistemleri

RESEARCH ARTICLE

Defence Expenditure and Financial Resources of Defence Expenditure in Turkey: A Comparative Conceptual Analysis 1-29

(Savunma Harcamaları ve Türkiye’de Savunma Harcamalarının Finansman Kaynakları: Karşılaştırmalı Kavramsal Bir Analiz)

Mehmet Bilge Kağan ÖNAÇAN, Volkan SEZGİN, Tunç Durmuş MEDENİ, İhsan Tolga MEDENİ

Computer Engineering / Bilgisayar Mühendisliği

RESEARCH ARTICLE

Supervised Machine Learning-based Classification of Network Threats/Attacks Against Computer Systems 31-59

(Bilgisayar Sistemlerine Yönelik Ağ Tabanlı Tehditlerin/Saldırıların Denetimli Yapay Öğrenme ile Sınıflandırılması)

Ercan KURU, Tolga ÖNEL, Mehmet Bilge Kağan ÖNAÇAN, Musa MİLLİ

Physics / Fizik

RESEARCH ARTICLE

Single Phase Measurement in UME Kibble Balance - 3 61-77

(UME Kibble Balans – 3 ile Tek Fazda Ölçüm)

Beste KORUTLU

NATIONAL DEFENCE UNIVERSITY
BARBAROS NAVAL SCIENCES AND ENGINEERING INSTITUTE
JOURNAL OF NAVAL SCIENCES AND ENGINEERING

VOLUME: 18

NUMBER: 1

APRIL 2022

ISSN: 1304-2025

CONTENTS / İÇİNDEKİLER

Physics / Fizik

RESEARCH ARTICLE

Radiative Corrections to Neutrino Mass in Type-3/2 Seesaw Mechanism

(Tip-3/2 Tahtarevalli Mekanizmasında Nötrino Kütlesine Gelen Işınımsal Düzeltmeler)

Canan Nurhan KARAHAN

79-89

Electric-Electronic Engineering / Elektrik-Elektronik Mühendisliği

RESEARCH ARTICLE

Photovoltaic System Design and Analysis at Faculty Scale

(Fakülte Ölçeğinde Fotovoltaik Sistem Tasarımı ve Analizi)

Sevgi ALTINKÖK, Serdar KARADENİZ, Atılgan ALTINKÖK

91-120

Mathematics / Matematik

RESEARCH ARTICLE

A Golden Section Method for the Multi-objective Fractional Solid

Transportation Problem Using the Exponential Membership Function

(Çok Amaçlı Üç Boyutlu Kesirli Taşıma Problemi için Üstel Üyelik Fonksiyonu Kullanarak Altın Oran Metodu)

Nurdan KARA, Hale GONCE KÖÇKEN

121-141

MİLLİ SAVUNMA ÜNİVERSİTESİ
BARBAROS DENİZ BİLİMLERİ VE MÜHENDİSLİĞİ ENSTİTÜSÜ
DENİZ BİLİMLERİ VE MÜHENDİSLİĞİ DERGİSİ

CİLT: 18

SAYI: 1

NİSAN 2022

ISSN: 1304-2025