

Electronic ISSN: 1309-0267



**International Journal
of Engineering &
Applied Sciences**

**I
J
E
A
S**

IJEAS

**Volume 14, Issue 4
2022**

Published by Akdeniz University

HONORARY EDITORS

(in alphabetical order)

- Prof. Atluri, S.N.- University of California, Irvine-USA
Prof. Liew, K.M.- City University of Hong Kong-HONG KONG
Prof. Lim, C.W.- City University of Hong Kong-HONG KONG
Prof. Liu, G.R.- National University of Singapore- SINGAPORE
Prof. Nath, Y.- Indian Institute of Technology, INDIA
Prof. Omurtag, M.H. -ITU
Prof. Reddy, J.N.-Texas A& M University, USA
Prof. Saka, M.P.- University of Bahrain-BAHRAIN
Prof. Shen, H.S.- Shanghai Jiao Tong University, CHINA
Prof. Xiang, Y.- University of Western Sydney-AUSTRALIA
Prof. Wang, C.M.- National University of Singapore- SINGAPORE
Prof. Wei, G.W.- Michigan State University-USA

EDITOR IN CHIEF:

Assoc. Prof. Ibrahim AYDOGDU -Akdeniz University *aydogdu@akdeniz.edu.tr*

ASSOCIATE EDITORS:

R.A. Kadir MERCAN –Mehmet Akif Ersoy University *kmercan@mehmetakif.edu.tr*

SECTION EDITORS:

- Assoc. Prof. Mustafa Arda –Trakya University
Assist. Prof. Refik Burak Taymuş- Van 100. Yıl University

EDITORIAL BOARD

(The name listed below is not Alphabetical or any title scale)

- Prof. Xinwei Wang -Nanjing University of Aeronautics and Astronautics
Asst. Prof. Francesco Tornabene -University of Bologna
Asst. Prof. Nicholas Fantuzzi -University of Bologna
Assoc. Prof. Keivan Kiani - K.N. Toosi University of Technology
Asst. Prof. Michele Baccocchi -University of Bologna
Asst. Prof. Hamid M. Sedighi -Shahid Chamran University of Ahvaz
Prof. Yaghoub Tadi Beni -Shahrekord University
Prof. Raffaele Barretta -University of Naples Federico II
Prof. Meltem ASİLTÜRK -Akdeniz University *meltemasilturk@akdeniz.edu.tr*
Prof. Metin AYDOĞDU -Trakya University *metina@trakya.edu.tr*
Prof. Ayşe DALOĞLU - KTU *aysed@ktu.edu.tr*
Prof. Oğuzhan HASANÇEBİ - METU *oguzhan@metu.edu.tr*
Asst. Prof. Rana MUKHERJİ - The ICFAI University
Assoc. Prof. Baki ÖZTÜRK - Hacettepe University
Assoc. Prof. Yılmaz AKSU -Akdeniz University
Assoc. Prof. Hakan ERSOY- Akdeniz University
Assoc. Prof. Mustafa Özgür YAYLI -Uludağ University
Assoc. Prof. Selim L. SANİN - Hacettepe University
Asst. Prof. Engin EMSEN -Akdeniz University
Prof. Serkan DAĞ - METU
Prof. Ekrem TÜFEKÇİ - İTÜ

ABSTRACTING & INDEXING



IJEAS provides unique DOI link to every paper published.

EDITORIAL SCOPE

The journal presents its readers with broad coverage across some branches of engineering and science of the latest development and application of new solution algorithms, artificial intelligent techniques innovative numerical methods and/or solution techniques directed at the utilization of computational methods in solid and nano-scaled mechanics.

International Journal of Engineering & Applied Sciences (IJEAS) is an Open Access Journal

International Journal of Engineering & Applied Sciences (IJEAS) publish original contributions on the following topics:

Civil Engineering: numerical modelling of structures, seismic evaluation, experimental testing, construction and management, geotechnical engineering, water resources management, groundwater modelling, coastal zone modelling, offshore structures, water processes, desalination, waste-water treatment, pavement and maintenance, transport and traffic, laser scanning, and hydrographic surveying, numerical methods in solid mechanics, nanomechanic and applications, microelectromechanical systems (MEMS), vibration problems in engineering, higher order elasticity (strain gradient, couple stress, surface elasticity, nonlocal elasticity)

Electrical Engineering: artificial and machine intelligence and robotics, automatic control, bioinformatics and biomedical engineering, communications, computer engineering and networks, systems security and data encryption, electric power engineering and drives, embedded systems, Internet of Things (IoT), microwaves and optics.

Engineering Mathematics and Physics: computational and stochastic methods, optimization, nonlinear dynamics, modelling and simulation, computer science, solid state physics and electronics, computational electromagnetics, biophysics, atomic and molecular physics, thermodynamics, geophysical fluid dynamics, wave mechanics, and solid mechanics.

Mechanical Engineering: machine design, materials science, mechanics of materials, manufacturing engineering and technology, dynamics, robotics, control, industrial engineering, ergonomics, energy, combustion, heat transfer, fluids mechanics, thermodynamics, turbo machinery, aerospace research, aerodynamics, and propulsion.

IJEAS allows readers to read, download, copy, distribute, print, search, or link to the full texts of articles.



CONTENTS

Accurate Small Sized Load Bearing Components Displacement Analysis

By Kadir Mercan 100-110



Accurate Small Sized Load Bearing Components Displacement Analysis

Kadir Mercan

Department of Civil Engineering, Faculty of Architecture-Engineering, Burdur Mehmet Akif Ersoy University

*E-mail address: kmercan@mehmetakif.edu.tr

ORCID numbers of authors:
0000-0003-3657-6274

Received date: 30.12.2022

Accepted date: 31.12.2022

Abstract

Load bearing components with cross sections in scale of millimeters attracted popularity with the advance in material engineering. As standard size scale of load bearing structures are around 100 times bigger than millimeter sized components, classical stability analyzes may be insufficient to simulate all stress and strains in load bearing structures which may lead to fail in whole structure. In this paper, the displacement analysis of small cross-sectional load bearing metals is presented using finite element analyzes and higher order elasticity theory. To take the size effect into consideration surface elasticity theory is selected. It is obtained higher order analyzes results differs from F.E.A. results. This result reveals that classical methods are insufficient to give accurate success in millimeters scale.

Keywords: ANSYS, Small cross section, Stability, Structural Steel, Surface Elasticity.

1. Introduction

Progress in materials engineering in recent years has been enormous, as has progress in small-scale engineering. Metal-based components such as aluminum, which are traditionally used as weak but inexpensive, have recently been strengthened and used as both durable and inexpensive materials. Durable material symbolizes that the load to which the material will be exposed at the application area is multiplied by a certain safety factor, and that it can safely carry the service load to be obtained, complies with the definition of durable material for the end user and engineers. Other prominent features of metal-based component can be stated as light-weight and ease to working on such as cutting and welding.

Traditional houses need to be constructed with components in meter scale while this has changed in some circumstance. Due to the rise in interest to living in tiny houses the size of structural elements used in constructions got smaller sizes. It is seen that the effects of the structural load and environmental loads that the carrier components will carry in the construction will be much smaller compared with traditional structures [1]. The decrease in carrying load will lead to decrease in structural components. Furthermore, the progress in composite materials allows to use more durable composite structural components with lower production cost [2, 3]. Furthermore, the advance in composite material allow to use components with smaller cross section [4]. Composite materials has the advantage of customize the end product in the way needed [5].



Analyzes on composite structures are not as formidable as analyzes on nanostructures. Setting up a new laboratory to perform nano sized analyzes can reach astronomical costs while the cost is lower in millimeter scaled engineering. Due to the ease of perform multiple analyzes at same time and no need to laboratory, researchers prefer to perform analyzes using classical mechanic [6-9] which leads to give non-accurate results, taking the size effect into consideration using higher order continuum theories such as strain gradient [10-13], modified strain gradient [12], couple stress [11, 14, 15], modified couple stress [16, 17], nonlocal elasticity [18-21], surface elasticity [22-26] etc. Also, finite element [27, 28] and DSC method [29-34] methods were also used to perform analyzes. Furthermore, modal and bending analyzes of nano sized structures has been investigated using classical and size effective theories [35-43]. Theoretical works are promising in case of the ability to perform hundreds of analyzes in very short time without the need of a laboratory and specimen [44-53].

Owing to the development in material technology, carrier components with much smaller cross-sectional areas are now being used in the skeletons of structures. Aluminum is frequently used in non-bearing components in structures due to its low price and ease of processing [54]. Due to the developments in composite materials, it has now been possible to find composite materials that are much more durable than aluminum [55, 56]. Although the price of these composite materials is not very low, composite materials are gradually replacing structural steel for ease of use in small areas and to avoid production-transport costs [57, 58].

In this paper the displacement analyzes of traditional and small sized components are performed using finite element analysis (F.E.A.) and surface energy theory.

2. Traditional and Small Sized Load Bearing Components

Traditional steel has been used in meter scale in constructions since more than a century with cross sections in centimeter scale. Accurate performance analyzes has been made for traditional scale not only for structural steel but for other metals and metal based composites. Both in meter and millimeter scaled structural steel analyzes will be performed using ANSYS and surface energy theory.

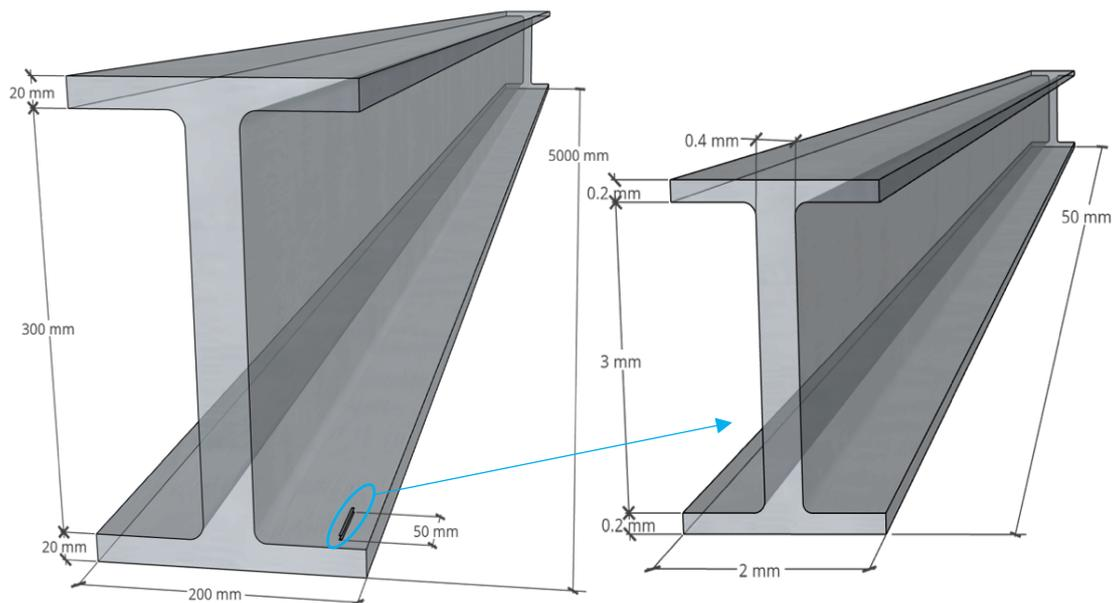

Fig. 1. Traditional vs. small sized load bearing structural steel

Examined structural load bearing components are selected with standard I cross section. The difference between the size scale of small sized and traditional components is demonstrated in left side of Fig. 1 by locating the small sized component at the right-bottom side of traditional sized component (in blue circle). Detailed geometric values of two components are also given in Fig. 1.

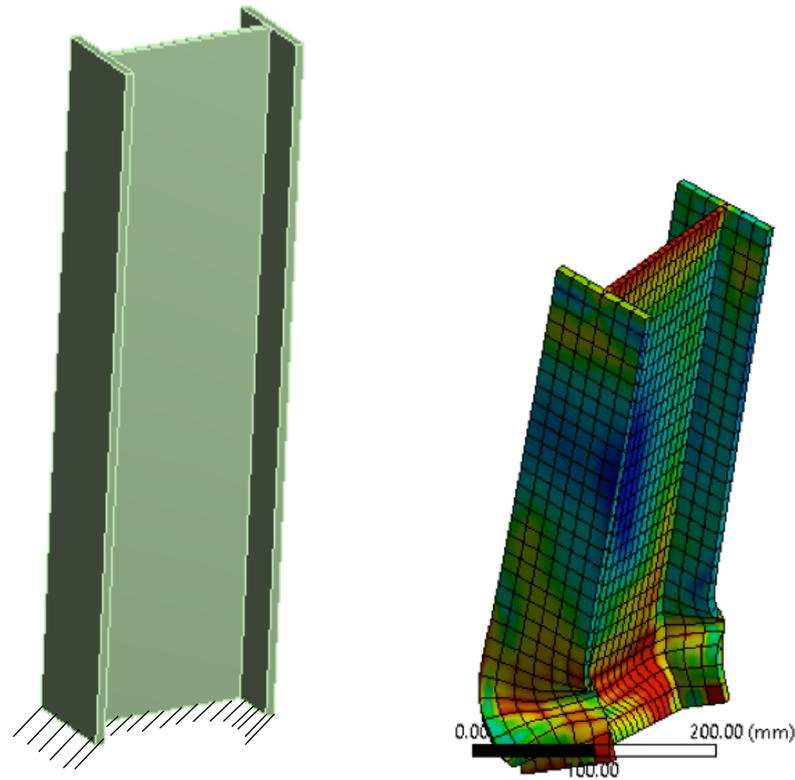

Fig. 2. Unloaded vs loaded structure component

The unloaded and loaded components are demonstrated in Fig. 2. As it can be seen from the figure the component is fixed from the bottom side to the ground while the load is applied to the top side of component. The stress distribution in component body is demonstrated in blue-red graded gradient. Also, the meshing is shown at the right side of Figure 2.

3. Finite Element Analysis and Surface Energy Theory

Traditional steel has been used in meter scale in constructions since more than a century with cross sections in centimeter scale. Accurate performance analyzes has been made for traditional scale not only for structural steel but for other metals and metal based composites. Both in meter and millimeter scaled structural steel analyzes will be performed using F.E.A. software ANSYS and surface energy theory.

When the displacement is equal to zero, the residual surface tension has no effect. But in case of any displacement, the residual surface tension creates a transversely distributed load “ $q(x)$ ” in the longitudinal direction. This distributed load (Laplace-Young) can be expressed as:

$$q(x) = H \frac{d^2 w}{dx^2} - k_w w + k_p \frac{d^2 w}{dx^2} \quad (1)$$

The parameter “H” given in Eq. (1) is a constant depending on the residual surface tension and can be calculated as [59]:

$$H = 2\tau^0 h \quad (2)$$

Where “ τ^0 ” is residual surface tension. Substituting Eq. (2) in Eq. (1):

$$(-\overline{EI} + P\mu - H\mu - k_p\mu) \frac{\partial^4 w}{\partial x^4} + (H + k_w\mu - P + k_p) \frac{\partial^2 w}{\partial x^2} - k_w w = 0 \quad (3)$$

Here “ μ ” is the non-local parameter and is equal to $(e_0 a)^2$, “ k_w ” and “ k_p ” are the foundation parameters “Winkler” and “Pasternak” respectively which will be neglected in current calculations.

4. Result and Discussions

Results are obtained using 0.2 second time step. Structural steel is selected as both traditional and small scaled components with geometric values given in Figure 1. In Table 1 F.E.A. results are given for structural steel with traditional and small size. Specimens are selected in geometric values given in Figure 1 without foundation effect. Displacements of component top part, force reaction at the fixed end and maximum stress in component body are calculated for each time step until 5.4 seconds. Results are given in Table 1 comparing traditional and small sized components.

Table 1. F.E.A. results

Time	<i>Traditional Component</i>			<i>Small Sized Component</i>		
	Displacement (mm)	Force reaction (N)	MAX stress (MPa)	Displacement (mm)	Force reaction (N)	MAX stress (MPa)
0.2	0.1838	8222.50	36.2470	0.01080882	483.676471	2.13217647
0.4	0.3675	16445.00	72.5400	0.02161765	967.352941	4.26705882
0.7	0.5513	24667.00	108.8800	0.03242647	1451	6.40470588
1	0.7350	32890.00	145.2600	0.04323529	1934.70588	8.54470588
1.2	0.9188	41112.00	181.6800	0.05404412	2418.35294	10.6870588
1.4	1.1025	49335.00	218.1500	0.06485294	2902.05882	12.8323529
1.6	1.2862	57557.00	254.6700	0.07565882	3385.70588	14.9805882
1.8	1.4700	65753.00	237.1200	0.08647059	3867.82353	13.9482353
2	1.6537	73241.00	236.8200	0.09727647	4308.29412	13.9305882
2.2	1.8375	77481.00	237.2600	0.10808824	4557.70588	13.9564706
2.4	1.4700	61032.00	195.4500	0.08647059	3590.11765	11.4970588
2.6	1.1025	44587.00	153.8400	0.06485294	2622.76471	9.04941176
2.8	0.7350	28142.00	112.8000	0.04323529	1655.41176	6.63529412
3	0.3675	11697.00	73.3620	0.02161765	688.058824	4.31541176

3.2	0.0000	-4747.50	73.1190	-9.143E-17	-279.26471	4.30111765
3.4	-0.3675	-21192.00	132.9100	-0.0216176	-1246.5882	7.81823529
3.6	-0.7350	-37637.00	193.2400	-0.0432353	-2213.9412	11.3670588
3.8	-1.1025	-54022.00	235.0000	-0.0648529	-3177.7647	13.8235294
4	-1.4700	-68985.00	235.0000	-0.0864706	-4057.9412	13.8235294
4.2	-1.8375	-77491.00	236.7400	-0.1080882	-4558.2941	13.9258824
4.4	-1.4700	-61044.00	191.5000	-0.0864706	-3590.8235	11.2647059
4.6	-1.1025	-44599.00	150.4100	-0.0648529	-2623.4706	8.84764706
4.8	-0.7350	-28154.00	109.9700	-0.0432353	-1656.1176	6.46882353
5	-0.3675	-11710.00	71.8930	-0.0216176	-688.82353	4.229
5.2	0.0000	4735.20	73.7120	-2.874E-16	278.541176	4.336
5.4	0.3675	21180.00	133.3000	0.02161765	1245.88235	7.84117647

After the load is applied from the upper end to the component, which is stationary at the initial moment, displacement, force reaction and maximum stresses are calculated for each 0.2 second time interval, respectively, and the results are shown in Table 1. Similar to first loading cycle the load was applied in a cyclic manner, pushing and pulling. Different responses to load cycle were observed for conventional and small scaled components during the loading. Obtained higher order results indicate that the scale effect is affecting the behavior and internal forces in component body.

Table 2. Higher order results

Time	<i>Traditional Component</i>			<i>Small Sized Component</i>		
	Displacement (mm)	Force reaction (N)	MAX stress (MPa)	Displacement (mm)	Force reaction (N)	MAX stress (MPa)
0.2	0.1838	8222.50	36.2470	0.01307225	490.991759	2.16651498
0.4	0.3675	16445.00	72.5400	0.02404451	981.981418	4.33367675
0.7	0.5513	24667.00	108.8800	0.03501676	1472.94122	6.50364504
1	0.7350	32890.00	145.2600	0.04598901	1963.96074	8.67600184
1.2	0.9188	41112.00	181.6800	0.05696126	2454.92054	10.8507472
1.4	1.1025	49335.00	218.1500	0.06793352	2945.94005	13.0284781
1.6	1.2862	57557.00	254.6700	0.07890278	3436.89986	15.2091947
1.8	1.4700	65753.00	237.1200	0.08987802	3926.30712	14.1612326
2	1.6537	73241.00	236.8200	0.10084729	4373.43762	14.1433187
2.2	1.8375	77481.00	237.2600	0.11182253	4626.6205	14.1695924
2.4	1.4700	61032.00	195.4500	0.08987802	3644.40233	11.6729944
2.6	1.1025	44587.00	153.8400	0.06793352	2662.42301	9.18833887
2.8	0.7350	28142.00	112.8000	0.04598901	1680.44369	6.73771976
3	0.3675	11697.00	73.3620	0.02404451	698.464373	4.38276079
3.2	0.0000	-4747.50	73.1190	0.0021	-283.48509	4.36825055
3.4	-0.3675	-21192.00	132.9100	-0.0198445	-1265.4345	7.93854701
3.6	-0.7350	-37637.00	193.2400	-0.041789	-2247.4139	11.5410288
3.8	-1.1025	-54022.00	235.0000	-0.0637335	-3225.8104	14.0346412
4	-1.4700	-68985.00	235.0000	-0.085678	-4119.2951	14.0346412
4.2	-1.8375	-77491.00	236.7400	-0.1076225	-4627.2134	14.1385417
4.4	-1.4700	-61044.00	191.5000	-0.085678	-3645.1147	11.4371282

4.6	-1.1025	-44599.00	150.4100	-0.0637335	-2663.1354	8.98352348
4.8	-0.7350	-28154.00	109.9700	-0.041789	-1681.156	6.56873214
5	-0.3675	-11710.00	71.8930	-0.0198445	-699.23644	4.29504248
5.2	0.0000	4735.20	73.7120	0.0021	282.754819	4.40366032
5.4	0.3675	21180.00	133.3000	0.02404451	1264.72219	7.96183506

4. Conclusions

Cross-sections of structural components get smaller everyday with the advance in material and composite engineering. As the conventional and small scaled components have 100 times difference in size, the effect of small cross-section should be taken into consideration using higher order theories. In this paper the displacement analysis of conventional and small scaled structural components is investigated using finite element method and surface energy theory. Maximum displacements, force reactions at fixed end, and maximum stress in the component body for two specimens is compared. It is clearly seen that the effect of small scale should not be neglected as results differs in this scale.

References

- [1] Calluari, K.A., Alonso-Marroquín, F., Structural analysis of an off-grid tiny house. *AIP Conference Proceedings*, 1856(1), 020001, 2017.
- [2] Eghbalian, M., Ansari, R., Haghghi, S., On the mechanical properties and fracture analysis of polymer nanocomposites reinforced by functionalized silicon carbide nanotubes: A molecular dynamics investigation. *Journal of Molecular Graphics & Modelling*, 111, 2022.
- [3] Aly, K., Lubna, M., Bradford, P.D., Low density, three-dimensionally interconnected carbon nanotube/silicon carbide nanocomposites for thermal protection applications. *Journal of the European Ceramic Society*, 41(1), 233-243, 2021.
- [4] Zhang, S., Schoenitz, M., Dreizin, E.L., Mechanically alloyed Al–I composite materials. *Journal of Physics and Chemistry of Solids*, 71(9), 1213-1220, 2010.
- [5] Clyne, T.W., Hull, D., *An introduction to composite materials* 2019; Cambridge university press, 2019.
- [6] Wang, Y., Wang, X.X., Ni, X.G., Wu, H.A., Buckling behavior of carbon nanotube under compression. *Acta Physica Sinica*, 52(12), 3120-3124, 2003.
- [7] Wang, C.Y., Ru, C.Q., Mioduchowski, A., Elastic buckling of multiwall carbon nanotubes under high pressure. *Journal of Nanoscience and Nanotechnology*, 3(1-2), 199-208, 2003.

- [8] Li, C., Guo, W.L., Continuum mechanics simulation of post-buckling of single-walled nanotubes. *International Journal of Nonlinear Sciences and Numerical Simulation*, 4(4), 387-393, 2003.
- [9] Akgöz, B., Mercan, K., Demir, Ç., Civalek, Ö., Static analysis of beams on elastic foundation by the method of discrete singular convolution. *International Journal of Engineering and Applied Sciences*, 8(3), 67-73, 2016.
- [10] Fleck, N., Hutchinson, J., Strain gradient plasticity. *Advances in applied mechanics*, 33, 296-361, 1997.
- [11] Yang, F., Chong, A., Lam, D.C., Tong, P., Couple stress based strain gradient theory for elasticity. *International Journal of Solids and Structures*, 39(10), 2731-2743, 2002.
- [12] Arda, M., Evaluation of optimum length scale parameters in longitudinal wave propagation on nonlocal strain gradient carbon nanotubes by lattice dynamics. *Mechanics Based Design of Structures and Machines*, 1-24, 2020.
- [13] Arda, M., Buckling Analysis of Intermediately Supported Nanobeams via Strain Gradient Elasticity Theory. *International Journal of Engineering and Applied Sciences*, 12(4), 163-172, 2022.
- [14] Reddy, J., Microstructure-dependent couple stress theories of functionally graded beams. *Journal of the Mechanics and Physics of Solids*, 59(11), 2382-2399, 2011.
- [15] Zhou, S., Li, Z., Length scales in the static and dynamic torsion of a circular cylindrical micro-bar. 2001.
- [16] Asghari, M., Kahrobaiyan, M.H., Ahmadian, M.T., A nonlinear Timoshenko beam formulation based on the modified couple stress theory. *International Journal of Engineering Science*, 48(12), 1749-1761, 2010.
- [17] Akgöz, B., Civalek, O., Analysis of microtubules based on strain gradient elasticity and modified couple stress theories. *Advances in Vibration Engineering*, 11(4), 385-400, 2012.
- [18] Eringen, A.C., On differential equations of nonlocal elasticity and solutions of screw dislocation and surface waves. *Journal of applied physics*, 54(9), 4703-4710, 1983.
- [19] Eringen, A.C., *Nonlocal continuum field theories* 2002; Springer Science & Business Media, 2002.

- [20] Arda, M., Axial dynamics of functionally graded Rayleigh-Bishop nanorods. *Microsystem Technologies-Micro-and Nanosystems-Information Storage and Processing Systems*, 27(1), 269-282, 2021.
- [21] Arda, M., Kısmi yayılı yük etkisindeki nano kirişlerin dinamik analizi. *Mühendislik Bilimleri ve Tasarım Dergisi*, 8(2), 417-428, 2022.
- [22] Dingreville, R., Qu, J., Cherkaoui, M., Surface free energy and its effect on the elastic behavior of nano-sized particles, wires and films. *Journal of the Mechanics and Physics of Solids*, 53(8), 1827-1854, 2005.
- [23] Mercan, K., Civalek, Ö., Buckling Analysis of Silicon Carbide Nanotubes (SiCNTs). *International Journal of Engineering & Applied Sciences (IJEAS)*, 8(2), 101-108, 2016.
- [24] Rahmani, O., Asemani, S., Hosseini, S., Study the surface effect on the buckling of nanowires embedded in Winkler–Pasternak elastic medium based on a nonlocal theory. *Journal of Nanostructures*, 6(1), 90-95, 2016.
- [25] Sharma, P., Ganti, S., Size-dependent Eshelby’s tensor for embedded nano-inclusions incorporating surface/interface energies. *Journal of Applied Mechanics*, 71(5), 663-671, 2004.
- [26] Sharma, P., Ganti, S., Bhate, N., Effect of surfaces on the size-dependent elastic state of nano-inhomogeneities. *Applied Physics Letters*, 82(4), 535-537, 2003.
- [27] Numanoglu, H.M., Mercan, K., Civalek, O., Finite element model and size-dependent stability analysis of boron nitride and silicon carbide nanowires/nanotubes. *Scientia Iranica*, 26(4), 2079-2099, 2019.
- [28] Mercan, K., Civalek, Ö., Modal Analysis of Micro and Nanowires Using Finite Element Softwares. *International Journal of Engineering and Applied Sciences*, 10(4), 291-304, 2018.
- [29] Civalek, Ö., Kiracioglu, O., Free vibration analysis of Timoshenko beams by DSC method. *International Journal for Numerical Methods in Biomedical Engineering*, 26(12), 1890-1898, 2010.
- [30] Demir, C., Mercan, K., Civalek, O., Determination of critical buckling loads of isotropic, FGM and laminated truncated conical panel. *Composites Part B-Engineering*, 94, 1-10, 2016.

- [31] Ersoy, H., Mercan, K., Civalek, O., Frequencies of FGM shells and annular plates by the methods of discrete singular convolution and differential quadrature methods. *Composite Structures*, 183, 7-20, 2018.
- [32] Mercan, K., Baltacioglu, A.K., Civalek, O., Free vibration of laminated and FGM/CNT composites annular thick plates with shear deformation by discrete singular convolution method. *Composite Structures*, 186, 139-153, 2018.
- [33] Mercan, K., Ebrahimi, F., Civalek, O., Vibration of angle-ply laminated composite circular and annular plates. *Steel and Composite Structures*, 34(1), 141-154, 2020.
- [34] Mercan, K., Demir, Ç., Civalek, Ö., Vibration analysis of FG cylindrical shells with power-law index using discrete singular convolution technique. *Curved and Layered Structures*, 3(1), 2016.
- [35] Hadji, L., Avcar, M., Civalek, Ö., An analytical solution for the free vibration of FG nanoplates. *Journal of the Brazilian Society of Mechanical Sciences and Engineering*, 43(9), 418, 2021.
- [36] Civalek, O., Avcar, M., Free vibration and buckling analyses of CNT reinforced laminated non-rectangular plates by discrete singular convolution method. *Engineering with Computers*, 2020.
- [37] Avcar, M., Hadji, L., Civalek, Ö., Natural frequency analysis of sigmoid functionally graded sandwich beams in the framework of high order shear deformation theory. *Composite Structures*, 276, 114564, 2021.
- [38] Hadji, L., Avcar, M., Nonlocal free vibration analysis of porous FG nanobeams using hyperbolic shear deformation beam theory. *Advances in Nano Research*, 10(3), 281-293, 2021.
- [39] Arda, M., Torsional Vibration Analysis of Carbon Nanotubes Using Maxwell and Kelvin-Voigt Type Viscoelastic Material Models. *European Mechanical Science*, 4(3), 90-95, 2022.
- [40] Civalek, Ö., Baltacioglu, A.K., Free vibration analysis of laminated and FGM composite annular sector plates. *Composites Part B: Engineering*, 157, 182-194, 2019.
- [41] Civalek, Ö., Geometrically nonlinear dynamic and static analysis of shallow spherical shell resting on two-parameters elastic foundations. *International Journal of Pressure Vessels and Piping*, 113, 1-9, 2014.

- [42] Akgöz, B., Civalek, Ö., Vibrational characteristics of embedded microbeams lying on a two-parameter elastic foundation in thermal environment. *Composites Part B: Engineering*, 150, 68-77, 2018.
- [43] Demir, C., Mercan, K., Numanoglu, H.M., Civalek, O., Bending Response of Nanobeams Resting on Elastic Foundation. *Journal of Applied and Computational Mechanics*, 4(2), 105-114, 2018.
- [44] Mercan, K., Işık, Ç., Akgöz, B., Civalek, Ö., Coordinate Transformation for Sector and Annular Sector Shaped Graphene Sheets on Silicone Matrix. *International Journal of Engineering & Applied Sciences (IJEAS)*, 7(2), 56-73, 2015.
- [45] Mercan, K., Demir, Ç., Ersoy, H., Civalek, Ö., The effects of thickness on frequency values for rotating circular shells. *International Journal of Engineering & Applied Sciences (IJEAS)*, 8(1), 26-37, 2016.
- [46] Mercan, K., Ersoy, H., Civalek, O., Free Vibration of Annular Plates by Discrete Singular Convolution and Differential Quadrature Methods. *Journal of Applied and Computational Mechanics*, 2(3), 128-133, 2016.
- [47] Civalek, Ö., Free vibration of carbon nanotubes reinforced (CNTR) and functionally graded shells and plates based on FSDT via discrete singular convolution method. *Composites Part B: Engineering*, 111, 45-59, 2017.
- [48] Demir, Ç., Akgöz, B., Erdinç, M.C., Mercan, K., Civalek, Ö., Elastik bir ortamdaki grafen tabakanın titreşim hesabı. *Gazi Üniversitesi Mühendislik-Mimarlık Fakültesi Dergisi*, 32(2), 2017.
- [49] Demir, C., Akgöz, B., Erdinc, M.C., Mercan, K., Civalek, O., Free vibration analysis of graphene sheets on elastic matrix. *Journal of the Faculty of Engineering and Architecture of Gazi University*, 32(2), 551-562, 2017.
- [50] Mercan, K., Akgöz, B., Demir, Ç., Civalek, Ö., Frequencies Values of Orthotropic Composite Circular and Annular Plates. *International Journal Of Engineering & Applied Sciences*, 9(2), 55-65, 2017.
- [51] Numanoglu, H.M., Mercan, K., Civalek, Ö., Frequency and Mode Shapes of Au Nanowires Using the Continuous Beam Models. *International Journal of Engineering & Applied Sciences (IJEAS)*, 9(1), 55-61, 2017.
- [52] Ersoy, H., Mercan, K., Civalek, Ö., Frequencies of FGM shells and annular plates by the methods of discrete singular convolution and differential quadrature methods. *Composite Structures*, 183, 7-20, 2018.

- [53] Mercan, K., Civalek, Ö., Critical Buckling Load of SiCNTs: A Molecular Dynamics Study on Gas Sensing. *International Journal of Engineering & Applied Sciences (IJEAS)*, 14(1), 40-52, 2023.
- [54] Kumar, B., Kumar, P., Preparation of hybrid reinforced aluminium metal matrix composite by using ZrB₂: A systematic review. *Materials Today: Proceedings*, 61, 115-120, 2022.
- [55] Senthil, S., Raguraman, M., Thamarai Manalan, D., Manufacturing processes & recent applications of aluminium metal matrix composite materials: A review. *Materials Today: Proceedings*, 45, 5934-5938, 2021.
- [56] Prakash, D.S., Manish, M., Shubham, S., Synthesis and characterisation of chromium, eggshell and grinding sludge-reinforced aluminium metal matrix composite: an experimental approach. *Green Materials*, 0(0), 1-10, 2022.
- [57] Narhari Tekale, S., Dolas, D.R., Study of fabrication methods and various reinforcements with aluminium for automotive application – A review. *Materials Today: Proceedings*, 62, 2768-2773, 2022.
- [58] Boopathi, S., Thillaivanan, A., Pandian, M., Subbiah, R., Shanmugam, P., Friction stir processing of boron carbide reinforced aluminium surface (Al-B₄C) composite: Mechanical characteristics analysis. *Materials Today: Proceedings*, 50, 2430-2435, 2022.
- [59] Wang, G.-F., Feng, X.-Q., Timoshenko beam model for buckling and vibration of nanowires with surface effects. *Journal of Physics D: Applied Physics*, 42(15), 155411, 2009.