

The design of a single channel high-resolution digital seismic system and some geological results

Tek kanallık yüksek çözünürlüklü sayısal bir sismik tasarımı ve bazı teknolojik sonuçlar

Bedri Alpar¹, M. Ali Danışman², Erkan Göktaşan¹,

Ertuğrul Doğan¹, Valery Gainanov³, Alex Zverev⁴

¹ University of Istanbul, Institute of Marine Sciences and Management,
Vefa, 34470 Istanbul, Turkey.

² Dokuz Eylül University, Division of Geophysical Engineering,
Bornova, 35100 Izmir, Turkey.

³ Geont Marine Research Centre and Moscow State University,
Moscow, Russia.

⁴ Impedance Co. Ltd, Moscow, Russia.

Abstract

A single-channel high-resolution digital reflection seismic system has been developed. Some technical specifications are given for its hardware and software. The seismic sections obtained from the first trial runs were compared with neighbouring analog sections which were recorded in the area previously. Similar results were found with previous findings. However, the overall performance and better resolution of the new digital system enabled us to distinguish two new geological features. First, thin Holocene post-transgressional sediments were much more evident compared to the previous records. Secondly, the chaotic reflection patterns in the Oligocene units were not caused by slumps but by gas-bearing sediments; meaning that the gas charged sediments of the northern shelf area of the Black Sea continued on the southern shelf area.

Keywords: Seismic system, high-resolution, digital seismic data acquisition, Black Sea, seismic hardware, seismic data processing

Introduction

A single-channel high-resolution digital seismic system has been developed with a co-operative work among the University of Istanbul, Institute of Marine Sciences and Management, Moscow State University, and the Impedance Co. Ltd. The system uses a sparkarray as a source. Sparker sources, which operate by discharging a high-voltage electrical current between electrodes towed at shallow

depths, have seen widespread usage in the acquisition of high-signature. The system was first tested in the Black Sea. The study area is situated on the shelf area of the north-eastern approaches of the Strait of İstanbul (Figure 1) and had partly been explored by analog shallow seismic studies previously. The designed seismic system could be investigated in two parts; seismic hardware for data collection and seismic software for data registration and processing.

A. Seismic Hardware

The block diagram of the sparker seismic reflection system consists of a main unit (power supply, trigger) with two blocks, a personal computer, a seismic amplifier, a GPS receiver, a multielectrode sparkarray and a surface-towed high-resolution streamer (Figure 2). The power supply unit is constructed of two blocks (Figure 3). The first block contains a high voltage transformer, trigger circuit, charging current limiting capacitors and high voltage commutator. The second block contains a high voltage AC/DC converter and capacitors for energy storing.

High voltage transformer transforms the input voltage up to 1700 V. The converter converts AC energy into DC energy, simultaneously doubling the output voltage, so the capacitors are charged up to 5 kV electrical energy. High voltage commutator (carbon electrodes) switches high voltage energy to the sparkarray's multielectrodes according to the command from the external system through the trigger (impulse forming) unit.

The following elements are situated on the control panel of power supply unit: an external start impulse connector, an "external/internal start" switch, an internal start period switch, a voltmeter, a neon lamp (initiation indicator), a luminous diode (start circuit power supply indicator), a fuse and a control unit power supply switch. A power supply connector, a high voltage transformer power switch and a manual start button are fixed on the front panel of the first block. On the front panel of the second block, there are "on" and "off" switching push-buttons of the high voltage capacitors. More detailed information about the high voltage energy unit can be obtained from the principal circuit diagram of the system (Figure 1). Triggering may be commanded from the external system (computer) or from the internal timer (test mode). In test mode initiation period may be chosen between 0.5 and 2 seconds.

The surface-towed high-resolution short-monotrace streamer is in a 4 cm diameter polyvinyl-chloride tube, 10 meters in length, and encasing eleven PDS/22-2 hydrophones, spaced 60 cm apart. The seismic source (near surface-

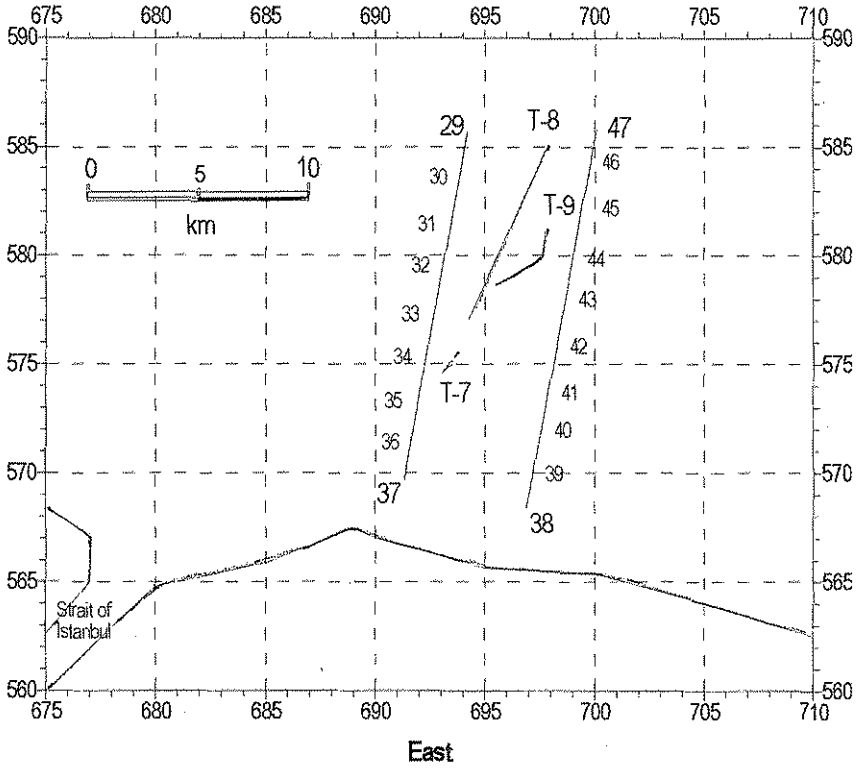

Figure 1. Location map of the seismic profiles. The DNHO's analog sections have the fix numbers between 29 and 47. T lines are the first test runs of the digital seismic system designed.

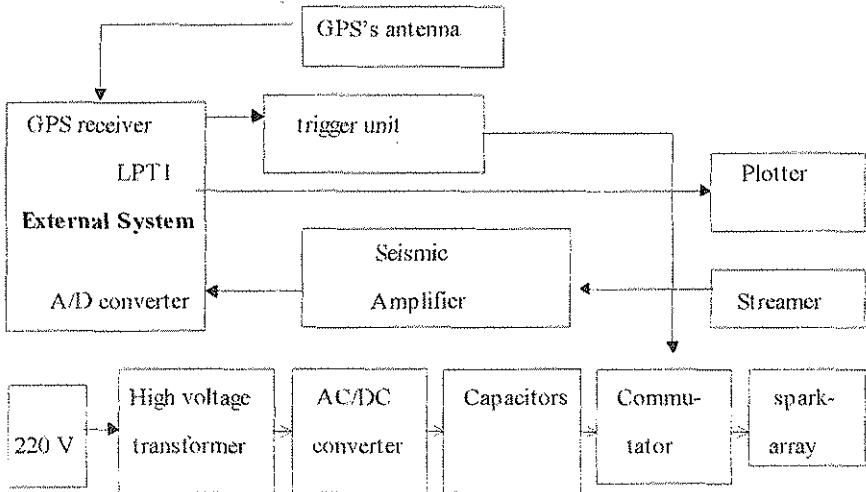

Figure 2. Schematic diagram of the digital seismic system designed in this study.

towed multielectrode sparkarray) is less than one meter in length with 30 discharging electrodes (6 kV and 30 mF), spaced about 5 cm apart.

A plotter is designed by modifying an ordinary fax machine (Panasonic KX-F 130). It is connected to the computer through the printer port and uses the thermal writing head of the fax machine for data recording on thermosensitive paper. Its writing resolution is 8 dots/mm and the number of dots in one line is 1600 (paper width is 210 mm). Unfortunately, it can not be used as a fax machine any more.

A compact GPS receiver module "SVeeSix-CM2" (Trimble, 1994) was interfaced with computer. The Global Positioning System (GPS) is a satellite based navigation system operated and maintained by the U.S. Department of Defence. Although originally conceived for military needs, GPS has a broad array of civilian applications especially for marine surveying. GPS is the most accurate technology available for vehicle navigation with an accuracy of ± 50 meters which is sufficient for pure geologic investigations.

Installation on board : The two blocks of the high voltage power unit must be connected to each other according to the block-diagram (Figures 2 and 3). The ground bolts of both blocks must be connected to each other and also to the ship's ground firmly by a copper wire (10 mm²). The necessary volumes of storing capacitors and current limiting capacitors must be set by choosing appropriate connectors.

The high voltage cable is connected to the high voltage commutator and its other end (sparkarray) is immersed into the sea. The carbon electrodes of high voltage commutator must be set in a position of approximately 2 mm from each other. This distance can be adjusted by and by. If it is impossible to turn the high voltage energy switch "on" or it runs irregularly, then carbon electrodes should be made closer to each other. If, to the contrary, switching "on" is arbitrary without a starting impulse, then the electrodes should be more distant.

The energy stored in capacitors is calculated as:

$$W = C * U * U / 2$$

where "U" is the stored energy voltage (5 kV) while "C" stands for the volume of capacitors. The two values of capacitors may be chosen by positioning special connectors (50 or 100 mcF). Therefore the stored energy is up to 1.25 kJ. In addition, the power supply is 220 VAC (3 kW). The charge storing period is 0.5 s and it depends on the value of the energy storing capacitors and on the value of charge current limiting capacitors. The value of the charge current limiting capacitors should be chosen so that the charge period is not more than the initiation period. By increasing the capacity of the current limiting capacitors, the current through the high voltage transformer and the power consumption will be increased. This leads to greater heating of the transformer and the power supply cable. Poor heat dissipation may cause damage to the equipment and even fire. So the power supply unit must be installed in a room with the humidity less than

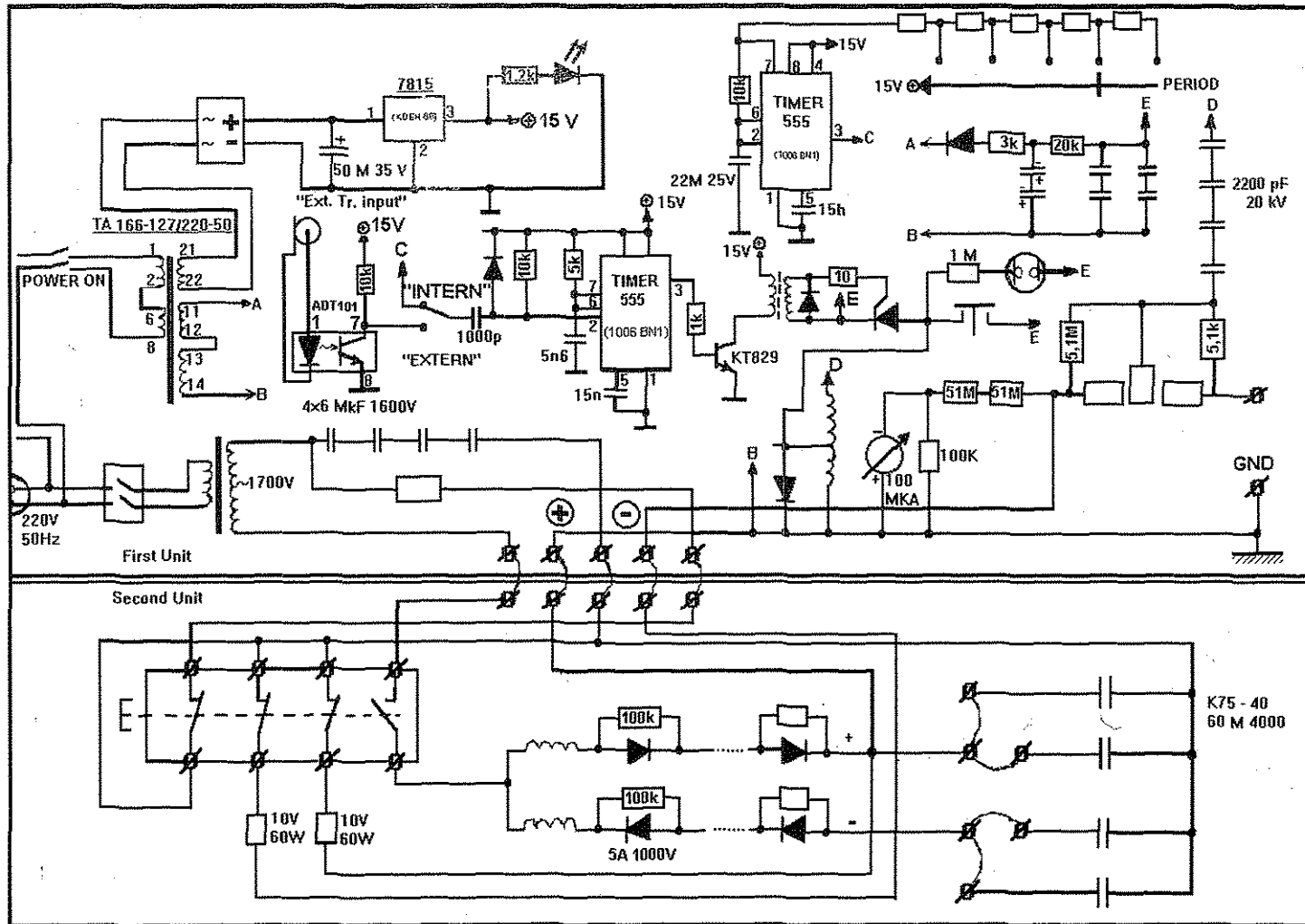

Figure 3. Circuit diagram of first and second blocs of seismic unit

70% and the temperature 10-27°C and the high voltage transformer should be ventilated depending on the weather conditions. The system must be fenced in and only certified personnel should be permitted inside the fence.

Field Operation : The operation sequences of power on or off should be obeyed strictly. Before turning the system on, the sparkarray should be immersed into the sea and all of the switches should be "off". Then power supply cable is connected and the power switch on the control panel is turned on. The triggering from the external system (computer) or in some cases from the internal timer is started. There must be a weak spark between the carbon electrodes following the triggering impulse. The high voltage to transformer is turned on, however, this is strictly prohibited if the triggering works improperly. The capacitor push button is switched on and fixed. An increasing voltage on the capacitors should be observed on the voltmeter. If the distance between the carbon electrodes is chosen properly then the system starts to work steadily.

On the other hand, to stop the operation, first the capacitors, and then the high voltage transformer should be turned off. The voltmeter should show a decrease till zero. The triggering circuit power supply switch should be turned off. The trigger capacitors should be discharged by pressing to the manual triggering button by several times. The power supply cable is disconnected. The high voltage energy capacitors should be discharged by blocking them by a special bar with an insulated handle.

B. Seismic Software

The seismic software for data acquisition, rewriting and processing contains five main programs modules which were written and compiled in C language (Borland C).

Data Acquisition Program : It is for data input through analog to digital converter (ADC), writing data on hard disc and output on plotter. It may start satellite data receiving if there is a GPS connected to the system. If no filename is specified there will be no writing on hard disc and this mode is useful for testing and tuning the equipment. Text annotations can be written in file headers for identification of the acquired data during processing and interpretation.

Any time delay of the traces may be applied but it is more convenient to choose the delay steps equal to 1/5 - 1/10 of the whole trace length. For analog to digital conversion, the sampling rate should be chosen by taking into account the seismic signal frequency range. It depends on several factors such as source type, its energy, towing depth and low-pass filter used. As a rule, the sampling rate should be $1/4F_h$, where F_h is the cut frequency of low-pass filter. So the cut frequency of low-pass filter should be chosen appropriately; for example, if F_h is 1000Hz, then the sampling rate (Δt) is 1/4 ms (250 microseconds). Other adjustable parameters are shot period in seconds, main amplifier gain, pre-amplifier gain (the whole amplifier gain is equal to the multiplication of main amplifier and pre-amplifier gains), high and low pass filter cut frequencies. The low pass filter cut frequency should be selected less than $1/(4*\Delta t)$. If the time-

varying-gain (TVG) is “off” then the amplifier gain is constant. If TVG is “on” then the amplifier gain changes by time linearly:

$$A = a * t / T \quad (0 < t < T),$$

where “a” is a constant value of gain and “T” is approximately one second.

The parameters for seismic data visualisation on screen are screen vertical scale, attenuation and screen delay. On the other hand, the parameters for seismic data visualisation on plotter are plotter on/off switch, trace length, plot vertical scale, plot delay, plot scan lines, attenuation, plot draw type (only black, black and white and grey), plot grey level, vertical time marks (ms), horizontal time marks (min) and horizontal trace marks (min).

For GPS receiver initialisation, a special commercial driver program should be uploaded before starting the main program and then GPS receiver will be set up and tested. The tested data will be displayed on screen indicating the current condition of GPS and possible reasons of failure, if occurs. During data acquisition, the navigation data and its health are written in trace headers at every shot. If navigation data is abnormal such as “no enough SV”, “error level is too high” etc., an instant warning message will appear on screen. In this case, program continues to write the previous navigation data in the trace header. In such cases, the operator has to decide either to continue data acquisition or stop fixing.

Once everything is set accordingly, data acquisition can be started. If no file name is specified it starts receiving data immediately. In other cases, after some security checks such as available space for avoiding unexpected stops during data acquisition and also existed data files to prevent accidental erasures, program creates a new data file and writes a file header with an annotation text.

The program follows the computer CMOS clock and initiates seismic source every shot period, requests GPS data, receives seismic data through ADC, make a record of trace header with necessary information (trace number, time, date, coordinates, registration parameters), writes data on disc, draws data on screen and plotter.

After starting the registration, the following procedures can be applied without stopping the data acquisition. The seismic delay value can be changed according to the steps which were previously set. An individual seismic trace or its specified portion can be projected on screen as if it is a cathode ray tube of an oscilloscope. This is convenient for looking some characteristics of the reflected waves such as amplitude and wave shape.

The binary block format of seismic trace header (48 bytes) and seismic data are as below (figures in parentheses indicate the byte number); the current trace number (0,1), trace length in samples, (2,3), sampling rate in microsecond (4,5), input gain (8,9), high-cut frequency in Hz (10,11), low-cut frequency in Hz (12,13), the distance between source and receiver in meters (14,15), profile number (16,17), system time (18-21), system date (22-25), health of GPS receiver

(26-27), latitude (28-31), longitude (32-35), magnetic data (36-39, reserved), annotation text (40-47) for seismic data header and finally the buffer for input trace (48-xx) for seismic data. The buffer length for input trace is specified by operator.

b. Data Rewriting Program : It is for reading file information, file header and seismic data from hard disc, displaying on screen and output on plotter. It starts same as the acquisition program and most of its parameters are chosen in the same way. However, the chosen parameters should fit to the existing input data. Some facilities were included to recover necessary information from files such as a menu for choosing file name, number of first trace and number of traces to read, and for reading the file header in which the some annotations and data registration parameters were contained. If these procedures have passed successfully, the program will be automatically set up for reading data from the chosen file. The trace length and the sampling rate may be entered manually.

Some auxiliary files should be existing in the working directory for graphic interface, ADC card initialisation and buffering GPS receiver. Program uses some certain initialisation files containing program parameter. If these files are absent at the beginning, program will be initiated with default parameters.

c. Plotting program (mapping utilities) : It is for reading seismic data and GPS data, displaying on screen, writing positioning information into an "ascii" file. These text files can be edited for any purpose. They can be used for plotting the seismic profiles and time fixes on a location map manually or by using some commercial programs such as "Surfer (Golden Software, Inc.)".

d. Seismic Data Processing Program : It is for single channel seismic data processing. The input and processed file names can be specified by user. However, it is recommended to give an extension according to the applied process type. Available processes are setting common delay, band-pass filtering, time varying gain control, re-sampling (needed before migration) and horizontal mixing. Some other seismic processes, such as deconvolution, multiple suppression, migration, polarity sections etc., are also written but they are not user friendly at the moment.

e. Image Program (Bitmap export) : It is for reading seismic data file, displaying on screen and output in graphic format on a laser jet printer or on a bitmap image file. These files can be used by commercial graphical programs such as Paint Shop Pro (Jasc Incorporated) or Corel Photo-Paint (Corel Corporation).

Data source and analytical techniques

Previous analog data : The test area was studied by the Department of Navigation, Hydrography and Oceanography on August 31st, 1995 with an analog 1 kJ (charged up to 40 kV electrical energy) sparker seismic system. Two of these seismic sections (Lines 29-37 and 38-47 in Figure 1) were used for comparison. These sections were recorded directly onto carbon paper with a EG&G graphic recorder (Model 255). A single channel streamer with 8 hydrophones (4.6 m in

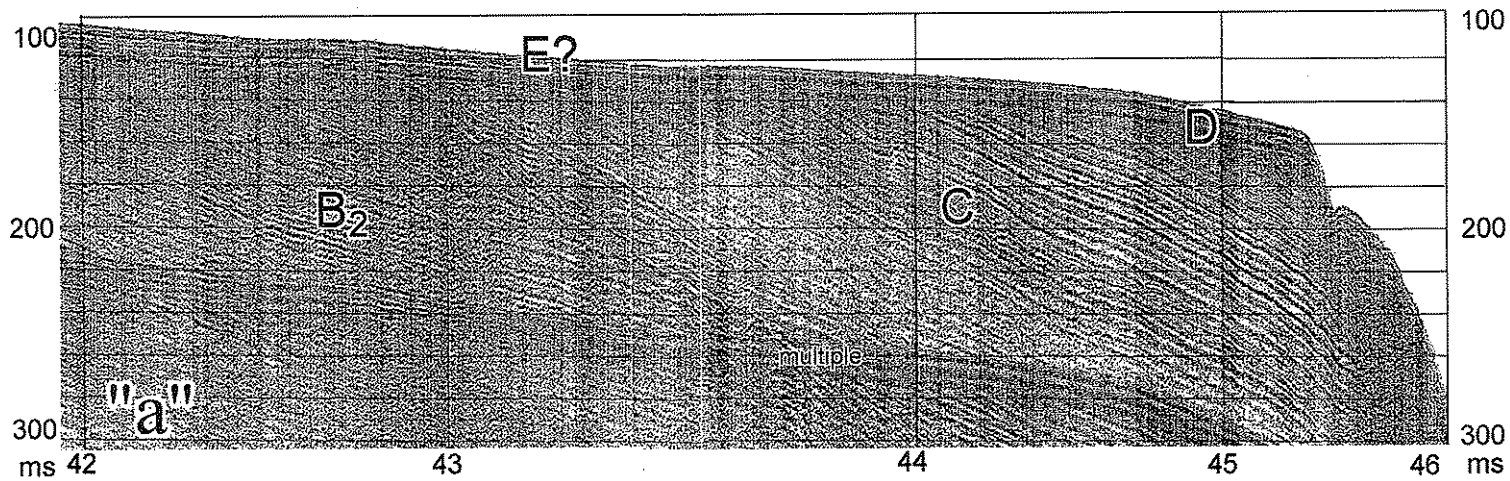

Figure 4. Comparison of the analog seismic section "a" (Courtesy DNHO) and the raw digital seismic test section "b" recorded over the subsequences B2 and C. See text for discussion.

length) and a sparkarray (3 electrode tow sled, 100-2000 Hz) with a 2 m typical resolution were used. A band pass filter and a linear TVG function were applied to the input signals. The vessel speed was held at 4.5 knots. The time interval between two successive shots was 3 s (about 7 m). The streamer and sparkarray were towed sufficiently aft of the vessel (about 30 m) to reduce the effects of ship-generated noises. The sea state was about two (personal communication with M. Şimşek). The record length was 400 ms two-way time and imaged the top 150 m or so of the subsurface (Figure 4a).

Digital test data : High resolution seismic reflection profiling was carried out in the study area (Figure 4b). The co-ordinates and operation local times of the start, break and end points of seismic profiles are given in Table 1.

Table 1. Location and time table of the recorded seismic profiles

Profile	Start Co-ordinates		Time	End Co-ordinates		Time
T-7	41:17.97	29:18.37	14:47:27	41:18:46	29:18.71	14:53:57
T-8	41:19:25	29:19:26	15:04:34	41:23:41	29:21.94	15:58:04
T-9a	41:21:23	29:21.84	16:35:04	41:20.71	29:21.70	16:41:24
T-9b	41:20.71	29:21.70	16:41:24	41:20:09	29:20.23	16:55:25

The sparkarray and streamer was deployed from the starboard of the vessel at a depth less than one metre below sea surface. They were towed at a distance of 30 m away from the stern and about 5-6 meters off the ship's route. The sparker was triggered each second and this temporal interval came about every 2.3 meters along the profile since the vessel speed was held about 4.5 knots during the studies. The analog signals coming from the streamer was pre-amplified (amplifying coefficient was 4500) and band pass filtered (15-250 Hz) with an analog filter and received on an Analog to Digital Converter electronic card in the computer. The digital time series were then processed and recorded on disk. The sampling rate was $\frac{1}{4}$ ms and the recording length was 250 ms (1000 samples) in two-way time. The display range was chosen as 200 ms for better appearance. These recording parameters and environmental conditions allowed us to penetrate more than 150 metres below sea bottom with a vertical resolution of about 2-5 meters which are in good agreement with the practical applications given by des Vallieres *et al.* (1978) for seismically hard environment.

Preliminary evaluation of the raw data is necessary for data quality control. Different band-pass filters were applied by utilising the amplitude spectra of the traces. Various plotting scales were also produced in order to verify most of the interesting parts of the sections.

Comparison of the results and discussion

a. Data quality: The observed performances of the tested and previous seismic systems show that digital recording may considerably enhance results (Figures 4 a and b). The penetration is, in both cases, limited to 150 m. However, the tested data seems to be much more clear and easy to interpret. These differences are mainly resulted from the configuration of data collection (charge energy, offsets, vessel speed, shot interval, etc.), recording parameters (instrumental response, analog filtering and gain adjustments), digital processing and weather conditions.

The performance of a data acquisition system depends primarily on the resolution of the source. The tested multielectrode sparkarray has reduced the pulse length and produced higher frequency signals. In addition, it seems that the ghost reflections were efficiently added to the down travelling wave train by towing the sparker at an efficient depth relative to the sea surface. This fact is also valid for streamer. The streamer depth should be equivalent to a quarter wavelength of the desired reception frequency and it can be calculated easily;

$$\lambda = 4 (f / v)$$

where λ is a quarter of the signal wavelength, f the average frequency, and v the velocity of sound. The streamer also needs to be set below the sea surface in order to reduce noise caused by surface waves and inherent cavitation, and increase acoustic coupling.

Single trace digital processing is limited (mostly filtering, deconvolution, gain control and horizontal stacking) but allows significant improvement in resolution due to signal contraction and multiple attenuation.

On the other hand, partly deteriorated quality of previous analog data may be resulted from the recording at higher speeds and in rougher sea conditions (both source and receiver are decoupled from the ship and surface wave motions). But no detailed records were found for the weather conditions during its acquisition. So the comparisons need go no further into the matter beyond these limits. Nevertheless the better performance and improved resolution of the new digital system enabled us to distinguish some new geological features.

b. Geology: According to the recent geophysical studies in the Black Sea and the Strait of Istanbul, the study area is placed on an important geologic region which was active in Holocene. The dating of recent sediments indicates that this region began to change its character partly 7000 years Bp and turned completely into the present condition 3000 years Bp (Ross, 1974). The Strait of Istanbul is a channel developed and deepened by fault activities in Quaternary. This allowed the Mediterranean origin waters to reach into the Black Sea (Gökaşan, 1997). The only marine geophysical study in this active region, except these two articles and some other unpublished cruise reports prepared by the Department of Navigation, Hydrography and Oceanography (DNHO), is done by Demirbağ *et al.* (1997). They have explained the recent geological evolution of the area by correlating the

land geology (Ketin and Kıran, 1990; Oktay *et al.*, 1992) with the DNHO's analog single-channel marine seismic sections (a part is given in Figure 4a representing the previous analog records). They defined four different seismic sequences from shore to shelf break depending on the reflection configuration and terminations and also the shape of the depositional sequences. From bottom to top they were given as; the upper Cretaceous - lower Eocene units (sequence A), the Oligocene units (sequence B), the lake deposits (sequence C) and the Pleistocene-Holocene deposits (sequence D). Oscillatory character of the bottom reflections did not let them to separate the thin Holocene deposits (E?), which are deposited in the depositional environment at present, from Pleistocene deposits. The Oligocene units observed on the previous analog records were divided into two sub sequences; B₁ and B₂. The sub sequence B₁ is closer to the shoreline and dives gently towards the Black Sea while B₂ is closer to the shelf break and contains occasional chaotic reflections. The sequence C were observed only in the vicinity of the approaches of the Strait of İstanbul and dated as before than the last glacial age (Würm). The sequence D onlaps sequences B and C (Demirbağ *et al.*, 1997).

All of these sequences can also be observed on our digital seismic sections. However, an important point designated between the previous analog records (Demirbağ *et al.*, 1997) and digital test records is the erosional truncation surface cutting all older units on the shelf area. This erosional surface can be observed on all analog sections more or less. It is the evidence that the studied part of shelf area was eroded until 7000 before present. Demirbağ *et al.* (1997) believed that actual sediments representing last 7000 years should be placed on top of the erosional surface. Because the previous analog data were affected by the reverberatory nature of the source wavelet (bubble pulse), the resulted ghost and wave trains masked the thin actual sediments in question. The better vertical seismic resolution in our test records allowed us to identify the actual Holocene sediments (E) much more detailed (Figure 4b) and helped us to prove the belief of Demirbağ *et al.* (1997).

On the other hand, Demirbağ *et al.*, (1997) have interpreted the sub sequence B₂, as much as enabled by the seismic resolution, as they were derived from the sub sequence B₁ as a result of some unstable movements such as slumps. Therefore these movements were imposed, in their paper in question, to be responsible for the chaotic reflections in B₂, (Figure 4a). However, in our test sections (Figure 4b), the gas-bearing sediments obviously seem to cause these chaotic reflections in the sub sequence B₂. The presence of shallow gas-bearing sediments is indicated on records by strong reflections, with underlying wipe-out zones and abrupt lateral changes in subbottom reflection characteristics. The offshore diving parallel to sub-parallel reflections of the Oligocene layers which were masked by gas-bearing and the absence of any discontinuity (or boundary) between the sub sequences B₁ and B₂ also support this idea obviously. Therefore, even though the classification of Demirbağ *et al.* (1997) for the sequence B into two sub sequences was appropriate, the limited resolution of the previous analog records prevented them to explain that this difference was a sign of the gas-bearing sediments. In deeper parts of this area, some tectonic processes and strong lateral stress fields,

which were possibly effective in the Miocene units (Finetti *et al.*, 1988), may weaken the upper part of the sedimentary sequences. Over pressure may be caused either by gas or fluid accumulations depending on the tectonic subsidence as well as on the sedimentation rate of deposits rich in organic material. Consequently, in addition to these findings, it can be claimed that the gas-bearing sediments densely observed in the northern shelf and shelf break areas (Unesco reports 56, 1992) continue on the southern shelf area, at least around the study area.

Özet

Uluslararası bir iş birliği ile tek-kanallı yüksek-çözünürlüklü sayısal bir sparker sismik sistemi geliştirilmiştir. Sistemin teknik donanım ve yazılım özellikleri detaylı olarak verilmektedir. İstanbul Boğazı Karadeniz çıkışında yapılan ilk denemede elde edilen sismik kesitler daha önce alışlagelmiş yöntemlerle kaydedilmiş komşu analog sparker kesitleri ile karşılaştırılmıştır. Eski kesitlere dayanılarak yapılan önceki çalışmalarda saptanan bulgulara ek olarak, yeni sistemin daha iyi performansı ve yüksek çözünürlüğü iki yeni bulgunun daha ortaya çıkartılmasına olanak vermiştir. Bunlardan ilki, transgresyon sonu ince Holosen çökellerinin eski çalışmalara göre çok daha belirgin olarak gözlenebilmesidir. İkincisi ise, Oligosen birimleri içindeki karmaşık yansıma desenlerine önceki çalışmalarda belirtildiği gibi sualtı heyelanlarının değil, gazlı çökellerin neden olduğunun saptanmasıdır. Bu durum Karadeniz kuzey şelf sahasında varolan gazlı çökellerin güney şelfinde de en azından çalışma sahası civarında bulunduğunu göstermektedir.

Acknowledgement

Head of Department Assoc. Prof. Dr. Captain H. Yüce of the Department of Navigation, Hydrography and Oceanography is thanked for supplying the analog seismic reflection data. Prof. Dr. E. Doğan is gratefully acknowledged for his financial and spiritual support to carry out this study. The authors appreciate the great care exerted in the field measurements by the scientists, technicians, Captain and crew on board the R/V Arar of the Istanbul University, Institute of Marine Sciences and Management.

References

- Demirbağ, E., Gökaşan, E., Oktay, F.Y., Şimşek, M. and Yüce, H. (1997). Seismic stratigraphic interpretation of the south-western Black Sea shelf and its implication about the last sea level changes (submitted).
- Des Vallieres, T., Kuhn, H. and LeMoal R. (1978). Test of various high resolution seismic devices in hard bottom areas, Offshore Technology Conference, 10th Annual OTC, Houston, 1455-1465.
- Gökaşan, E., Demirbağ, E., Oktay, F.Y., Ecevitoglu, B., Şimşek, M., and Yüce, H. (1997). On the origin of the Bosphorus, Marine Geology (in press).
- Oktay, F.Y., Eren, R.H. and Sakınç, M. (1992). Karaburun-Yeniköy çevresinde (İstanbul) Doğu Trakya Oligosen havzasının sedimanter jeolojisi, Türkiye 9. Petrol Kongresi, Ankara.
- Ross, D.A. (1974). The Black Sea, in: The Geology of Continental Margins (Burk, C.A. and Drake, C.L., eds.), New York: Springer-Verlag, 669-682.
- Trimble (1994). SVeeSix - CM2 embedded GPS core module, System Designer Reference Manual, Trimble Navigation, 645 North Mary Avenue, CA, USA, 156p.
- Finetti, I., Bricchi, G., Del Ben, A., Pipan, M and Xuan, Z. (1988). Geophysical study of the Black Sea, *Bullettino di Geophysica, teorica ed applicata*, 30(117-118), 197-325.
- Unesco Reports 56. (1992). Geological and geophysical investigations in the Mediterranean and Black Seas, UNESCO reports in marine science, 208p.

Received:7/6/1997

Accepted: 20/6/1997