



OBTAINING THE PARAMETRIC POSITION EQUATIONS OF A FOUR-BAR MECHANISM USING THE PARAMETRIC POSITION EQUATIONS OF THE PLANAR MANIPULATOR WITH 3 REVOLUTE JOINTS (3RM)

Orhan Erdal AKAY 

Sütcü Imam University, Engineering Faculty, Mechanical Engineering Department, Kahramanmaraş, TURKEY
akayorhan@ksu.edu.tr

(Geliş/Received: 07.04.2020; Kabul/Accepted in Revised Form: 11.09.2020)

ABSTRACT: In a four-bar mechanism, the crank link rotates at a constant angular velocity, while the other two links have constantly changing angular velocities. If it is desired to convert a 3RM into a four-bar mechanism, the variable angular velocities of the rotary actuators at both ends of the coupler link should be accurate. The general parametric set of equations that give the cartesian coordinates of 3RM can be arranged so that they can be used for the four-bar mechanism by limiting the degree of freedom. In this case, the angular velocities of the actuators on both ends of the coupler link should be determined while the crank link rotates at a constant angular speed. Angular velocities of actuators have been obtained using the WorkingModel2D (WM2D) "dynamic motion-simulation software" for a four-bar mechanism, whose geometric parameters have been selected as the crank-rocker. Using the angular velocity data, unknown coefficients in polynomials expressing the angular velocities of the rotary actuators connected to the coupler link have been found using Mathematica software. The trajectory and angular velocity data have been obtained from WM2D, the results of trajectory and angular velocity equations have been compared and the results have been at acceptable levels.

Key Words: Parametric model, four bar mechanism, 3R manipulator, inverse kinematic solution

Üç Döner Mafsallı Düzlemsel Manipulatörün (3RM) Parametrik Pozisyon Denklemlerini Kullanarak Bir Dört Çubuk Mekanizmasının Parametrik Pozisyon Denklemlerinin Elde Edilmesi

ÖZ: Bir dört çubuk mekanizmasında, kol uzvu sabit bir açısal hız ile dönerken, diğer iki uzuv sürekli değişen açısal hızlara sahiptir. Bir 3RM mekanizması, dört çubuk mekanizmasına dönüştürülmek istenirse, biyel uzvunun her iki ucundaki döner aktuatörlerin değişken açısal hızlarının doğru olarak belirlenmesini gerekir. 3RM'nin kartezyen koordinatlarını veren genel parametrik denklem seti serbestlik derecesi sınırlanarak dört çubuk mekanizması için kullanılabilir şekilde düzenlenebilir. Bu durumda kol uzvu sabit bir açısal hız ile dönerken, biyel uzvunun her iki ucundaki aktuatörlerin açısal hızları belirlenmelidir. Aktuatörlerin açısal hızları, geometrik parametreleri kol-sarkaç çalışmasına göre seçilen bir dört çubuk mekanizması için WorkingModel2D (WM2D) "dinamik hareket simülasyon yazılımı" kullanılarak elde edilmiştir. Açısal hız verileri kullanılarak, biyel uzvuna bağlı döner aktuatörlerin açısal hızlarını ifade eden polinomlardaki bilinmeyen katsayılar Mathematica yazılımı kullanılarak bulunmuştur. WM2D'den elde edilen yörünge ve açısal hız verileri, yörünge ve açısal hız denklemlerinin sonuçları karşılaştırılmış ve elde edilen sonuçların kabul edilebilir seviyelerde olduğu bulunmuştur.

Anahtar Kelimeler: Parametrik model, dört çubuk mekanizması, 3R Manipulatör, ters kinematik çözüm

1. INTRODUCTION

Theoretically, four bar mechanisms that can draw an infinite number of trajectories have a very important place in machine design. Trajectory synthesis has been one of the main areas of studies on these mechanisms. Because the position equations of the four-bar mechanisms are in non-linear form, various computer algorithms are used for their solutions (Roy *et al.*, 2008; Wampler *et al.*, 1992; Acharyya and Mandal, 2009; Hong-Sen Yan and Soong, 2001; Tang *et al.*, 2013; Dong *et al.*, 2013). In addition to the old research topics such as kinematics and dynamic analysis of four bar mechanisms, many interesting studies are carried out about bio-mechanisms (Alfaro *et al.*, 2004; Fujie *et al.*, 2013; Pennock and Yang, 1983).

Trajectory generation of a planar revolute manipulator (nRM) depends on geometric and kinematic parameters including, link dimensions, initial angular positions of the links and actuator velocities of the joints. Such mechanisms may be constructed by mechanically coupling the rotations of the links of an n -link, n degree of freedom serial chain manipulator using cable and pulley drives or gear-trains. Each coupling between two successive joint rotations reduces one DOF (Degrees of freedom) and repeated coupling reduces the overall degrees of freedom of the manipulator to one (Krovi *et al.*, 2002; Nie and Krovi, 2005; Vukobratovic and Kircanski, 1986). It is one of the important study topics in the adaptation of walking trajectory curves to robots in humanoid and animal mobile robots (Çatalakaya and Akay, 2018; Hirose and Ogawa, 2007; Shieh, 1996).

In the four-bar mechanisms which driven with angular velocity ω_1 , the angular velocities of the joints which the coupler link is connected vary with time [$\omega_2(t) \neq \omega_3(t)$]. The special case of this situation is parallelograms. In these mechanisms, absolute angular velocities are equal all of the joints ($\omega_1 = -\omega_2 = -\omega_3$). For this reason, parametric position equations of a 3RM ($\omega_1 = -\omega_2 = -\omega_3$) are also valid for a parallelogram (Fig 1a). The shape of the trajectory drawn by the parallelogram coupler undergoes a radical change when the length of the input link of the parallelogram is slightly reduced (Fig 1b). According to the Grashof theorem, the mechanism works with the crank-rocker character, with the condition " $l + s < p + q$ " is satisfied. This radical change is the result of the relationship of $\omega_2(t) \neq \omega_3(t)$ depending on the geometric change. In order to obtain the parametric position equations, it is necessary to obtain the equations that give the angular joint velocities $\omega_2(t)$ and $\omega_3(t)$. This study focuses on how to solve this problem.

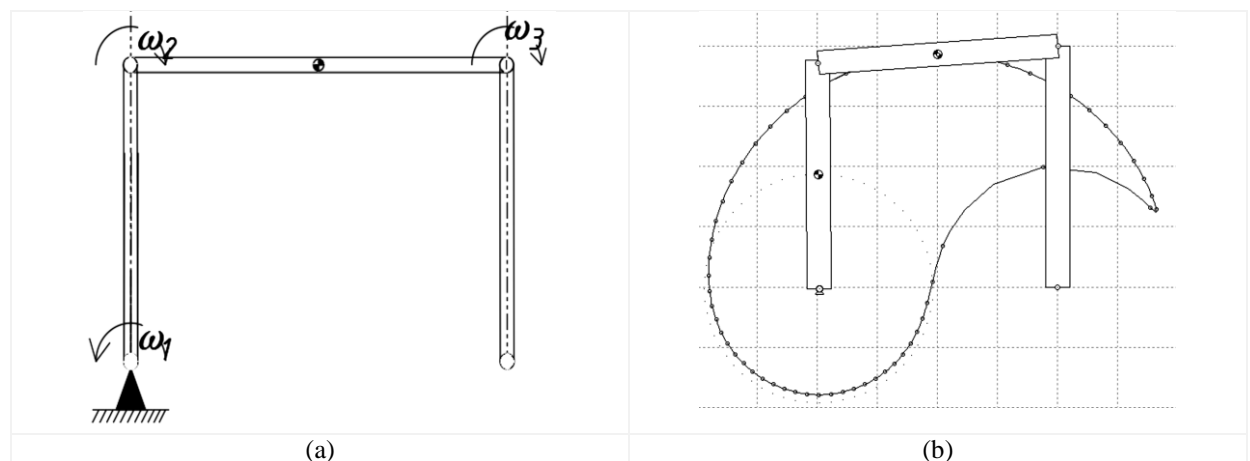

Figure 1. Schematic models of parallelogram and 3RM

The data used in the study have been obtained with the simulation software WM2D. Working Model 2D (WM2D) is a motion simulation package. By defining connected systems formed from rigid bodies, motors and springs, and defining constraining forces and torques. The program accepts imported data from popular CAD packages in DXF format in addition to systems created within its own environment, and furthermore will accept inputs from other applications such as Excel and Matlab to add control inputs to the models. There are various motion and dynamic analysis studies using this software (Cruz *et al.*, 2015; Shala and Bruqi, 2017; Wang, 2001; Wang, 1996; Yan and Soong, 2001)

2. GEOMETRIC AND PARAMETRIC MODEL

The geometric $(\theta_{1,2,3}, l_{1,2,3})$ and kinematic parameters $(\omega_{1,2,3})$ of the 3RM are shown in Fig 2 The reference point P_3 is the end point of the link l_3 . The point is P_{2m} the midpoint of the link l_2 .

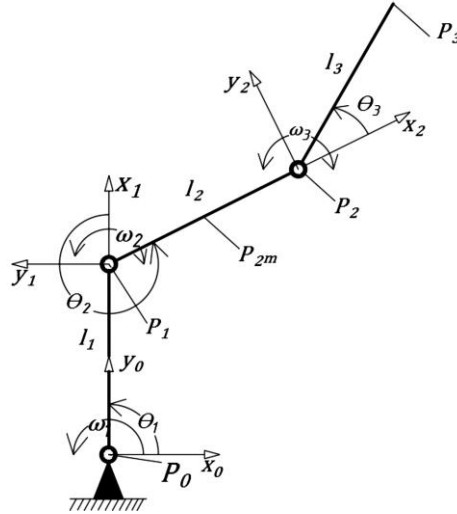

Figure 2. The geometric and kinematic parameters of the 3RM

The general position equations of the end effector $P_3(x_3, y_3)$ can be written in the parametric form according to initial angles $(\theta_{10,20,30})$ and time (t) parameters as follows;

$$P_{3x}(t) = l_1 \cos(\theta_{10} + \omega_1 t) + l_2 \cos[\theta_{10} + \theta_{20} + t(\omega_1 + \omega_2)] + l_3 \cos[\theta_{10} + \theta_{20} + \theta_{30} + t(\omega_1 + \omega_2 + \omega_3)] \quad (1)$$

$$P_{3y}(t) = l_1 \sin(\theta_{10} + \omega_1 t) + l_2 \sin[\theta_{10} + \theta_{20} + t(\omega_1 + \omega_2)] + l_3 \sin[\theta_{10} + \theta_{20} + \theta_{30} + t(\omega_1 + \omega_2 + \omega_3)] \quad (2)$$

Equations 1 and 2 give the correct results when $\omega_{1,2,3}$ are constant. The 3RM's DOF will be 3 under these conditions. On the condition that P_3 is fixed, the 3RM turns into a four-bar mechanism. Geometric and kinematic parameters of this mechanism are illustrated below (Fig. 3).

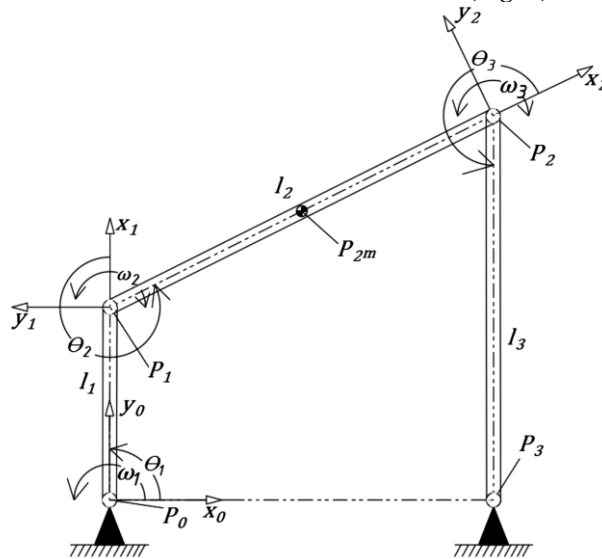

Figure 3. Geometric and kinematic parameters of four bar mechanism

The angular velocities ω_2 and ω_3 vary depending on the time. Therefore, the change of angular velocities should be investigated by taking into account the small-time intervals (t_s) obtained by dividing the time by n intervals. If equations 1 and 2 are arranged according to $\omega_1=\text{const.}$, $\omega_2(t)\neq\omega_3(t)$ for P_3 fixed joint coordinates, these equations take the form below:

$$P_{3x}(t) = l_1 \cos(\theta_{10} + nt_s \omega_1) + l_2 \cos(\sum_{i=1}^2 \theta_{i0} + t_s(i\omega_1 + \sum_{i=0}^n \omega_{2i})) + l_3 \cos(\sum_{i=1}^3 \theta_{i0} + t_s(i\omega_1 + \sum_{i=0}^n (\omega_{2i} + \omega_{3i}))) \quad (3)$$

$$P_{3y}(t) = l_1 \sin(\theta_{10} + nt_s \omega_1) + l_2 \sin(\sum_{i=1}^2 \theta_{i0} + t_s(i\omega_1 + \sum_{i=0}^n \omega_{2i})) + l_3 \sin(\sum_{i=1}^3 \theta_{i0} + t_s(i\omega_1 + \sum_{i=0}^n (\omega_{2i} + \omega_{3i}))) \quad (4)$$

Equations 3 and 4 can be applied to any point on the four bar mechanism, with the requirement of the dimensional and angular parameters according to any selected point. Table 1 summarizes the time-dependent variation of link angle according to the time (θ_{1i} , θ_{2i} , θ_{3i}). In these table the time interval is $t_s=0.05$ second;

Table 1. The time-dependent variation of θ_{1i} , θ_{2i} , θ_{3i}

i	t_i	$\theta_{1i}(t)$	$\theta_{2i}(t)$	$\theta_{3i}(t)$
0	0	θ_{10}	$\theta_{10}+\theta_{20}$	$\theta_{10}+ \theta_{20}+ \theta_{30}$
1	0.05	$(\theta_{10})+ \omega_1 t_s$	$(\theta_{10}+\theta_{20})+ t_s (\omega_1+ \omega_{21})$	$(\theta_{10}+ \theta_{20}+ \theta_{30})+ t_s (\omega_1+\omega_{21}+\omega_{31})$
2	0.10	$(\theta_{10}+\omega_1 t_s)+ \omega_1 t_s$	$(\theta_{10}+\theta_{20}+ t_s (\omega_1+ \omega_{21}))+ t_s (\omega_1+ \omega_{22})$	$(\theta_{10}+\theta_{20}+\theta_{30}+t_s(\omega_1+\omega_{21}+\omega_{31}))+ t_s(\omega_1+\omega_{22}+\omega_{32})$
.
n		$\theta_{10} + t_s n \omega_1$	$\theta_{10} + \theta_{20} + t_s \left(\sum_{i=0}^n i \omega_1 + \omega_{2i} \right)$	$\theta_{10} + \theta_{20} + \theta_{30} + t_s \left(\sum_{i=0}^n (i \omega_1 + \omega_{2i} + \omega_{3i}) \right)$

In order to use equations 3 and 4 it is necessary to obtain equations which give time-dependent variation of angular velocities ω_2 and ω_3 . For this we can define " $\omega_1+\omega_{2i}$ " and " $\omega_1+\omega_{2i}+\omega_{3i}$ " with polynomials which seventh degree. In these equations a_i and b_i are unknown constant coefficients. Although the degree of polynomial can be chosen smaller, the results of the accuracy will decrease and in the opposite case, the accuracy will increase.

$$i\omega_1 + \sum_{i=0}^n \omega_{2i} = \sum_{j=0}^7 a_j t^j \quad (5)$$

$$i\omega_1 + \sum_{i=0}^n (\omega_{2i} + \omega_{3i}) = \sum_{j=0}^7 b_j t^j \quad (6)$$

3. MODEL VALIDATION OF PARAMETRIC EQUATION SET

In order to validate equations 3-4, an inverse kinematic solution has been made. Kinematic data of the sample crank-rocker mechanism has been used to perform inverse kinematic solution. Geometric and kinematic parameters of the mechanism are randomly selected ($\omega_1=1$ rad/s, $l_0=P_0P_3=1$, $l_1=0.5$, $l_2=1.118$, $l_3=1$, $\theta_1=1.57$, $\theta_2=5.1836$, $\theta_3=4.2411$ rad.). The only limiting condition of these randomly selected criteria is that the mechanism works as a crank-rocker. The mid-point trajectory of the coupler has been selected for investigation ($P_{2m(x,y)}$). Data of WM2D simulation software has been used to get the unknown coefficients (a_j, b_j). One period time of the mechanism movement is divided into $n=126$ time intervals as $t_s=0,05$ seconds. For curve fitting process 127 angular velocity data, $[(\omega_1+\omega_{2i}(t_i)), (\omega_1+\omega_{2i}(t_i)+\omega_{3i}(t_i))]$ has been used for each equation (5-6). Accuracy settings of the WM2D which has been used in the study are given in Fig 4.

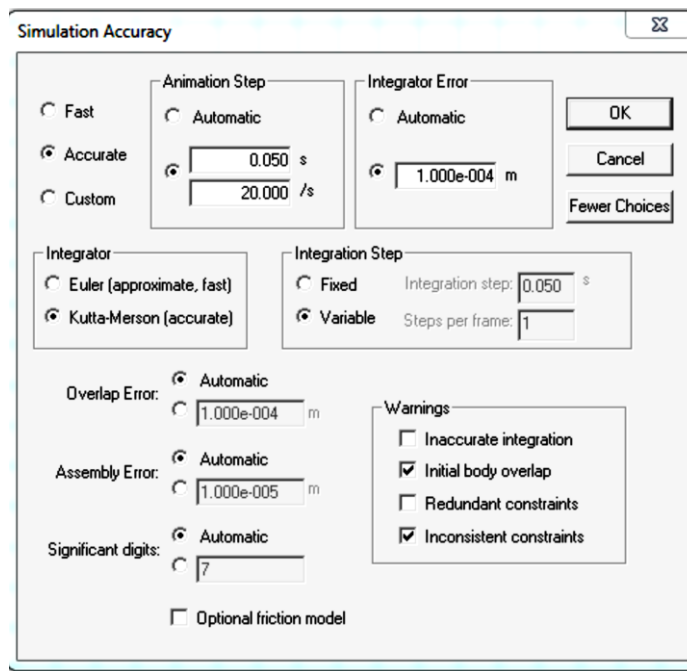

Figure 4. WM2D accuracy settings

Constant coefficients ($a_j, b_j, 0 \leq j \leq 7$) have been calculated by NonlinearModelFit function with Mathematica software using WM2D data ($(\omega_1 + \omega_{2i}(t_i))$, $(\omega_1 + \omega_{2i}(t_i) + \omega_{3i}(t_i))$). Screen capture of Mathematica software has given in Fig.5.

```
nlmw12 = NonlinearModelFit[dataw12, w12, {{a7, 0}, {a6, 0}, {a5, 0}, {a4, 0}, {a3, 0}, {a2, 0}, {a1, 0}, {a0, 0}}, t]
Normal[nlmw1+2]
nlmw12[{"ParameterTable", "RSquared"}]
Show[ListPlot[dataw12], Plot[nlmw12[t], {t, 0, 6.30}], Frame -> True, FrameLabel -> {"t(s)", "w1+2"}]

nlmw123 = NonlinearModelFit[dataw123, w123, {{b7, 0}, {b6, 0}, {b5, 0}, {b4, 0}, {b3, 0}, {b2, 0}, {b1, 0}, {b0, 0}}, t]
Normal[nlmw123]
nlmw123[{"ParameterTable", "RSquared"}]
Show[ListPlot[dataw123], Plot[nlmw123[t], {t, 0, 6.30}], Frame -> True, FrameLabel -> {"t(s)", "w1+2+3"}]
```

Figure 5. Screen capture of Mathematica

4. RESULT AND DISCUSSION

Four bar mechanism arranged according to geometric and kinematic parameters has been simulated with WM2D ($0 \leq t \leq 6.30$). As a result of the simulation, $(\omega_1 + \omega_{2i}(t_i))$, and $(\omega_1 + \omega_{2i}(t_i) + \omega_{3i}(t_i))$ angular velocities, cartesian coordinates of the $P_{2mx}(t)$ and $P_{2my}(t)$ points have been obtained depends on the time. Constant coefficients ($a_j, b_j, 0 \leq j \leq 7$) have been calculated by NonlinearModelFit function with Mathematica software using WM2D data ($(\omega_1 + \omega_{2i}(t_i))$, $(\omega_1 + \omega_{2i}(t_i) + \omega_{3i}(t_i))$). Screen capture of curve fittings results has given in Table 2.

Table 2. Curve fitting results

"Estimate"		"Estimate"		
a_7	-0.001813477812779328	b_7	-0.001185270220434778	
a_6	0.03390786004840107	b_6	0.01982784209897974	
a_5	-0.23682398067048188	b_5	-0.11727174842874329	
a_4	0.7721336909447628	$0.96532b_4$	0.2889999901177289	0.99997
a_3	-1.2242243493790288	b_3	-0.2415875300301827	
a_2	0.8586005844259332	b_2	-0.13316797699760774	
a_1	0.01469943760892944	b_1	0.20409794471981227	
a_0	0.00737108328376324	b_0	0.4448991323842059	

The numerical values of the coefficients have been placed in the equations 5 and 6 and the equations 7 and 8 given below were obtained.

$$\omega_{1+2} = 0.00737108328376324 + 0.01469943760892944t + 0.8586005844259332t^2 - 1.2242243493790288t^3 + 0.7721336909447628t^4 - 0.23682398067048188 + 0.03390786004840107t^6 - 0.001813477812779328t^7 \quad (7)$$

$$\omega_{1+2+3} = 0.444899132384216 + 0.20409794471982887t - 0.13316797699760435t^2 - 0.24158753003018377t^3 + 0.28899999011772887t^4 - 0.11727174842874326t^5 + 0.019827842098979743t^6 - 0.0011852702204347783t^7 \quad (8)$$

Variation of angular velocities has been calculated by using equations 7 and 8. The results and the graphs drawn by the data obtained from the WM2D simulation are given below (Fig 6a, b). In Fig 5a, R^2 (the coefficient of multiple determination for multiple regression) as 0.965 and in Fig 5b R^2 as 0.901 have been calculated. It is clear that better results can be obtained if the degree of the polynomial is increased.

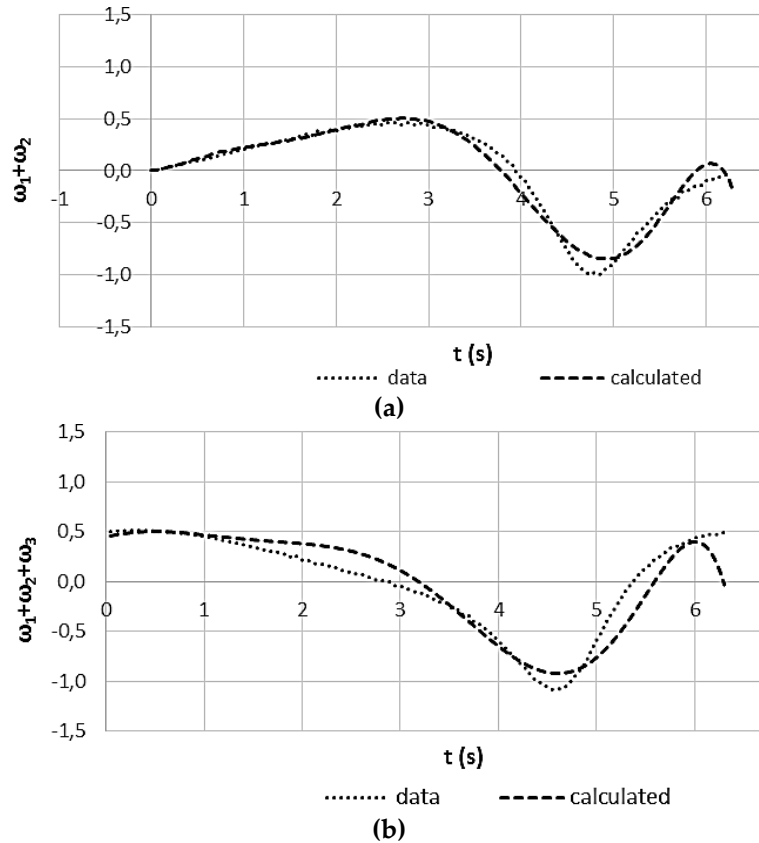

Figure 6. Angular velocities obtained by simulation data and calculation.

Coordinates of the mid point of the coupler $P_{2m}[x(t), y(t)]$ have been obtained according to angular velocity and geometric parameters ($\omega_1=1 \text{ rad/s}$, $l_0=1$, $l_1=0.5$, $l_2=0.559$, $l_3=0$, $\theta_1=1.57$, $\theta_2=5.1836$, $\theta_3=0$). According to these parameters' equation 3 and 4. are re-arranged. (Equation 9 and 10).

$$P_{2mx}(t) = l_1 \text{Cos}(\theta_{10} + nt_s \omega_1) + (l_2/2) \text{Cos}(\sum_{i=1}^2 \theta_{i0} + t_s(i\omega_1 + \sum_{i=0}^n \omega_{2i})) \quad (9)$$

$$P_{2my}(t) = l_1 \text{Sin}(\theta_{10} + nt_s \omega_1) + (l_2/2) \text{Sin}(\sum_{i=1}^2 \theta_{i0} + t_s(i\omega_1 + \sum_{i=0}^n \omega_{2i})) \quad (10)$$

WM2D simulation data and solving results of equations for P_{2mx} and P_{2my} are presented graphs below (Fig 7a,b). The R^2 's of the data were calculated 0.999 in both graphs. WM2D trajectory data (P_{2mx} , P_{2my}) has been used for calculation of R^2 .

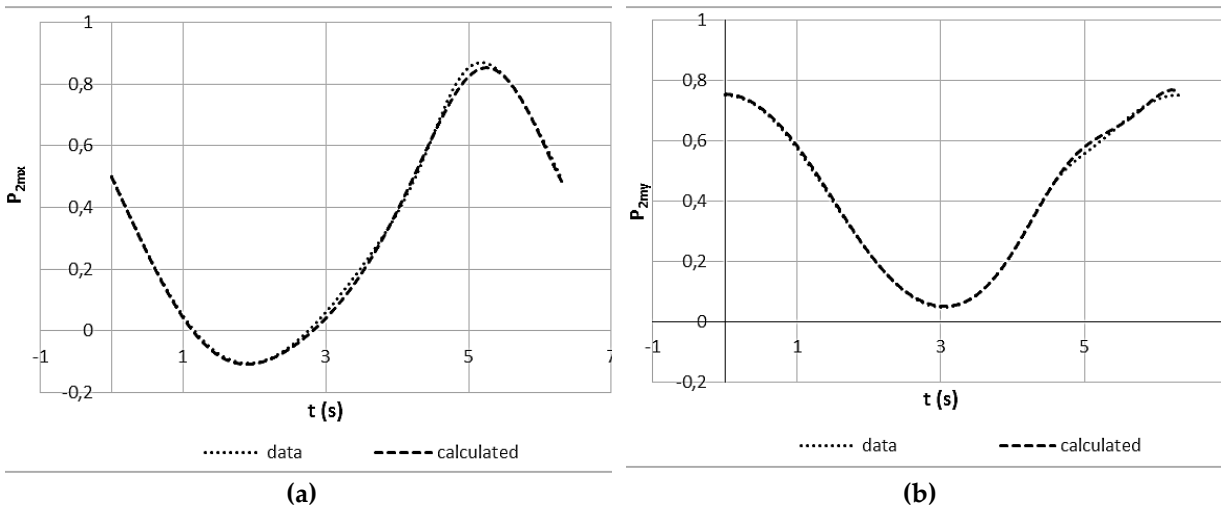

Figure 7. Time dependent change of coordinates P_{2mx} and P_{2my}

Figure 8 shows the trajectory of the point P_{2m} on the coupler. The curves in this graph are calculated results and WM2D simulation data. As can be seen from the graph, the trajectories drawn by the simulation and calculation results are quite similar.

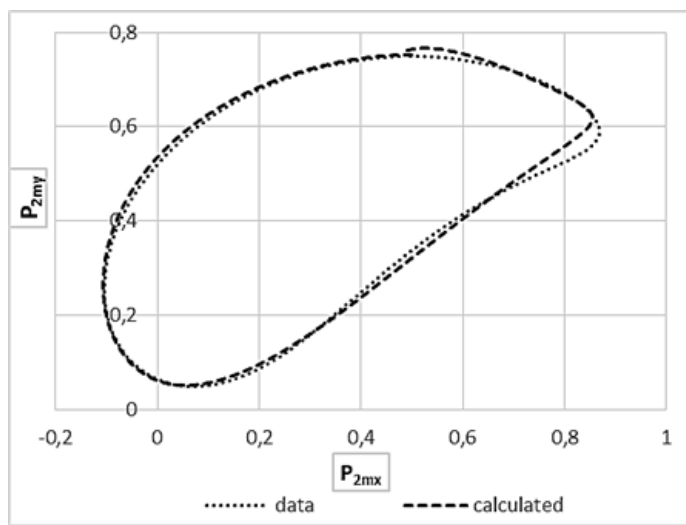

Figure 8. The graph of P_{2mx} and P_{2my}

In this study, it is focused on obtaining parametric general position equations of a four-bar mechanism. Therefore, parametric position equations of 3RM have been used, parametric position equations have been obtained for four-bar mechanism, limiting the degree of freedom to operate like a

four-bar mechanism. In order to test the validity of the assumptions and solutions to obtain these equations, a sample inverse kinematic solution has been applied and found to be quite compatible with the actual data. Although the parametric velocity and acceleration equations can be easily obtained with these equation sets, they are excluded from the study for not avoid of the focus point of the study. The parametric position equations have a suitable mathematical form for the time depended position synthesis of dimensional and kinematic parameters.

REFERENCES

- Acharyya, S. K., Mandal, M., 2009, "Performance of EAs for four-bar linkage synthesis", *Mechanism and Machine Theory* 44, 1784–1794.
- Alfaro, M. E., Bolnick, D. I., Wainwright, P. C., 2004, "Evolutionary Dynamics of Complex Biomechanical Systems: An Example Using the Four-Bar Mechanism", *Evolution*, Vol. 58, No. 3, pp. 495-503.
- Cruz, M., A., et al., 2015, "Modeling, Simulation and Construction of a Furuta Pendulum Test-Bed", *International Conference on Electronics, Communications and Computers (CONIELECOMP)*, 25-27 Feb. 2015, DOI: 10.1109/CONIELECOMP.2015.7086928.
- Çatalkaya, M., AKAY, O. E., 2018, "Obtaining Human Step Trajectory Curves Using 2R Manipulator", *Journal of Engineering Sciences*, ISSN: 1309-1751, Vol. 21, No. 3, 267-271.
- Dong, H., Du, Z., Chirikjian, G. S., 2013, "Workspace Density and Inverse Kinematics for Planar Serial Revolute Manipulators", *Mechanism and Machine Theory* Volume 70, 508-522.
- Fujie, H., Kimura, K., Yamakawa, S., "Static and Dynamic Properties of a 6-DOF Robotic System for Knee Joint Biomechanics Study", *Asme 2013 Summer Bioengineering Conference* Paper No. SBC2013-14849, pp. V01BT23A012; 2 pages DOI:10.1115/SBC2013-14849.
- Hirose, M., Ogawa K., 2007, "Honda humanoid robots development", *Philosophical Transactions of the Royal Society of London A: Mathematical, Physical and Engineering Science*, 365, 11-19.
- Krovi, V., Ananthasuresh, G. K., Kumar, V., 2002, "Kinematic and kinetostatic synthesis of planar coupled serial chain mechanisms", *Journal of Mechanical Design*, 124, 301-312.
- Leardini, A., Moschella, D., "Dynamic Simulation of the Natural and Replaced Human Ankle Joint", *Medical and Biological Engineering and Computing*, Volume 40, pages193–199(2002).
- Nie, X., Krovi, V., 2005, "Fourier Methods for Kinematic Synthesis of coupled serial chain", *Journal of Mechanical Design*, 127, 232-241.
- Pennock, G. R., Yang, A. T., 1983, "Dynamic Analysis of a Multi-Rigid-Body Open-Chain System," *J. Mech., Trans., and Automation* 105(1), 28-34, (7pages)doi:10.1115/1.
- Roy, L., Sen, A., Chetia, R. P., Borah, M. J., 2008, "Analysis and Synthesis of Fourbar Mechanism", *International Journal of Theoretical and Applied Mechanics* ISSN 0973-6085 Volume 3 Number 2, pp. 171–186.
- Shala, A., Bruqi, M., , August 2017, "Kinetostatic Analysis of six-bar Mechanism Using Vector Loops and The Verification of Results Using Working Model", *International Journal of Mechanical Engineering and Technology (IJMET)*, Volume 8, Issue 8, pp. 1109–1117.
- Shieh, W. B., 1996, Design and Optimization of Planar Leg Mechanisms Featuring Symmetrical Foot-Point Paths, Doctor of Philosophy, Department of Mechanical Engineering, University of Maryland, Maryland.
- Tang, Y., Chang, Z., Dong, X., Yafei Hu, Zhenjiang Yu, 2013, "Nonlinear Dynamics and Analysis of a Four-Bar Linkage with Clearance", *Frontiers of Mechanical Engineering*, 8(2): 160–168, DOI 10.1007/s11465-013-0258-6.
- Vukobratovic, M., Kircanski, M., 1986, "Kinematics and Trajectory Synthesis of Manipulation Robots", *Springer-Verlag*, ISBN-13: 978-3642821974.
- Wampler, C. W., Morgan, A. P., Sommese, A. J., 1992, "Complete Solution of the Nine-Point Path Synthesis Problem for Four-Bar Linkage", *Journal of Mechanical Design*, Vol. 114, pp. 153-159, doi:10.1115/1.2916909.

- Wang, S., L., Jun 2001, Motion Simulation with working Model 2D and MSC VisualNastran 4D, *J. Comput. Inf. Sci. Eng.*, 1(2): 193-196, <https://doi.org/10.1115/1.1389462>.
- Wang, S., L., Nov. 1996, "Mechanism Simulation With Working Model", *Technology-Based Re-Engineering Engineering Education Proceedings of Frontiers in Education FIE'96 26th Annual Conference*, 6-9, DOI10.1109/FIE.1996.567781.
- Yan, H. S., Soong, R. C., 2001, "Kinematic and Dynamic Design of Four-Bar Linkages by Links Counterweighing with Variable Input Speed", *Mechanism and Machine Theory* 36, 1051-1071.