

## **FAULT TOLERANT CONTROL OF ROTOR SWING STABILIZER SYSTEM USING FMEA METHOD**

Deniz ÖZTÜRK\*and Hakan AKYILDIZ\*\*  
*Istanbul Technical University / \* ozturkdeni@itu.edu.tr, \*\* akyildiz@itu.edu.tr*

### **ABSTRACT**

In this article, rotor swing stabilizer system has been analyzed according to fault tolerant control (FTC) methodology. Fault tolerant control is presented in a general framework and Failure Mode and Effects Analysis (FMEA) is applied as a fault analysis method. The focus was on the category of requirements, process and components to find risky elements and provide solutions. The general methodology covered the failure mode and effect analysis and implementation of fault tolerant control systems on an overall level but still have a potential for improving immunity to component faults.

**Keywords:** Magnus effect, Failure mode and effect analysis, Fault tolerant control, Stabilizer system.

### **1. Introduction**

Demand for marine and conventional transportation between ports increases with each passing day. It is important to minimize the possible risks in environment that exposed constant external forces. Rolling is an undesirable movement at sea, causes dangerous inclining, so stresses based upon roll motion on the hull should be avoided.

This work concentrates upon rotor swing stabilizer system [3, 5, 6] which is based upon studies at seventies and a feature of an emerging technology. Thanks to the Magnus effect phenomenon [4] which observed its effects at some ball sports, system creates lift to damping the roll motion with spinning cylinders. The rotor swing stabilizer system performs to create good stability on board is preferential for safety and comfort. However, potential risks of such automated systems which are vulnerable to fault should be considered while design phase. Defect in motion sensors, speed sensors or position sensors, servo valves and all the other parts of system can be examined by the closed-loop control systems circumstantially. Detection of possible faults makes it possible to tolerate constituent malfunctions.

To enhance the reliability, safety, economically and fault tolerance, it is important to plan control systems which are competent on tolerating potential faults, in a word, fault tolerant control [1, 2]. For increasing the performance of the rotor swing stabilizer system, new methods to control system design have been developed by using failure mode and effect analysis [7, 8].

### **2. Fault Tolerant Control**

At the point when a fault happens in a system, the fundamental issue to be tended to will be to raise a caution, in a perfect world analyses what shortcoming has happened, and afterward choose how to manage it. The issue of distinguishing a fault, finding the source/area and

afterward making proper move is the premise of fault tolerant control. Fault tolerant is the property that empowers a system to keep working legitimately in case of the disappointment of some of its segments. A fault tolerant configuration empowers a system to proceed with its planned operation, perhaps at a decreased level, as opposed to coming up short totally, when some of the parts in the system break down. In other words, the system all in all is not ceased because of failures either in the hardware or the software and the system merges towards an error free state. In the event that the outcome of a framework disappointment is so disastrous, the system must have the capacity to utilize inversion to fall back to a protected mode.

Redundant hardware has to be attached to automation for safety critical systems to not be affected by any failure. Fail operational systems are performed irresponsive to any single component fault. While a measurement specifies a serious fault, fail safe systems shut down the main system in a controlled manner. Stability and pre-allotted performance of the control loop is checked by robust control periodically. However, fault tolerant control checks the system online and identifies critical faults in the components. Development of fault in the failure will be preventable in case of identification of the fault. The plant has to be available thanks to the FTC system in spite of faults. It is possible that performance of the plant may reduce and what is worse humanity and environment may be damaged. Then, FTC system handles the faults by system reconfiguration.

FTC systems can be categorized into two groups as active (AFTC) and passive (PFTC). Active FTC differs from passive FTC in accordance with fault diagnosis and configuration commander mainly. In PFTCS, controllers are fixed and are designed to be robust against a class off presumed faults. However, AFTCS responds to system in an active way by reconfiguration so that stability and acceptable performance of the entire system can be maintained. Moreover, AFTCS has access to the fault of failure information with FDI before reconfiguration can be undertaken.

Since the scope of this work on the fault tolerant control, which is an active type of system, further details on the AFTCS were given just for brief information intended to gain better understanding of the whole picture. AFTCS reconfigure the control actions effectively. System performance and stability continues by this means and underperformance can be acceptable in some cases [2]. AFTCS named as self-repairing at one of the researches which worked on flight control systems and offered control surface reconfiguration and expert maintenance diagnostics as a technological development. The other denotation of AFTCS is reconfigurable which stabilizers closed loop performance despite control effector breakdowns by redistributing force and moment commands above the disrupted control suite to reduce the effect of breakdown. Fault tolerant-restructurable control and self-designing control systems are the other denotations of AFTCS. A real time FDD diagramming which shows the updated information from the system is important for prospering reconfigurable control systems. Moreover, a controller design leads to stabilize the system and qualify performance at both normal conditions of the functions and faulty circumstances in overall systems and also sub-systems. The approach of fault tolerant control and taken actions should be different for normal and faulty conditions for certain. Whereas maintaining the quality is the priority in normal conditions, recovery of the system with well accepted performance becomes crucial. In AFTCS, see Figure 1, the points to take into consideration are that,

- Design an easy to reconfigure controller,
- Design a high sensitive FDD scheme,

- Design a reconfiguration mechanism which guides by any means necessary to recover, of the preliminary fault system performance,
- Value the time which is restricted for the FDD and for the control system reconfiguration.

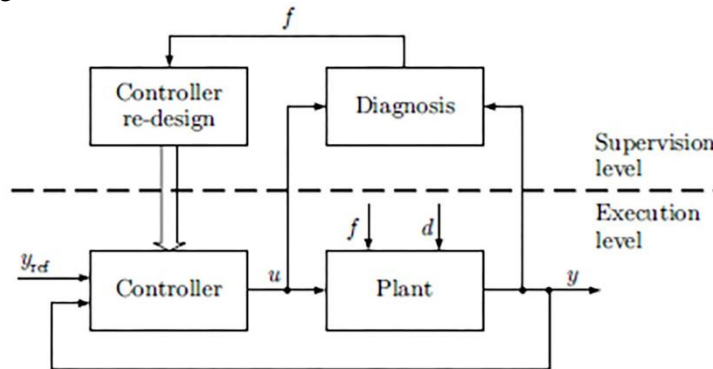

Figure 1. Basic scheme of a fault tolerant control system [1].

Fault diagnosis detects the faults in the system and isolates them as much as possible and all the variables, system status, output variables, and subsequent fault system models are required to be forecasted on line in real time. Reconfigurable controller is planned to continue stabilization, essential dynamic performance and steady-state performance on the basis of information coming from subsequent fault system.

### 3. Background Information about Rotor Swing Stabilizer System

Using a cylindrical structure as a stabilizer on both sides of the ship, see Figure 2, has been provided to benefit from the Magnus effect [3]. According to Magnus effect phenomenon, the cylinder rotated clockwise in water flow, which moves from left to right causes pressure difference around the cylinder. When increasing flow velocity causes to decrease pressure at the top of cylindrical structure, pressure will increase at the bottom of structure due to decreasing velocity. Therefore, the lifting force on a rotating cylinder is generated upward [4], and rolling motion at ships can be minimized due to righting moment (See Figure 3).

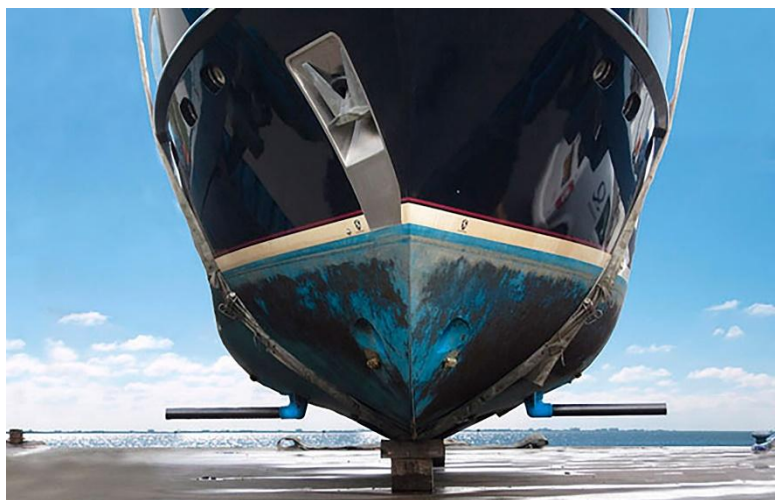
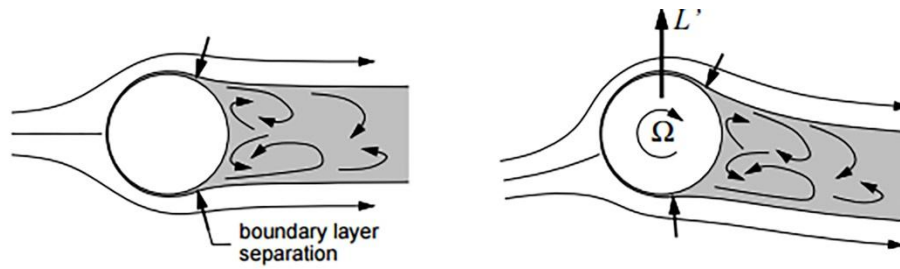
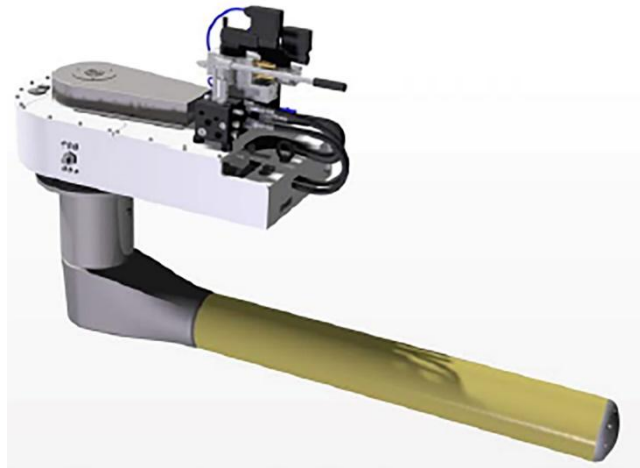

Figure 2. Location of rotor swing stabilizer on ship's hull [9].



**Figure 3.** Principle of Magnus effect [4].

Also, electromechanical system makes it possible to change rotation speed and direction of rotation so as to increase efficiency. Additively, placing the rotor horizontal to the sea level increases the capacity of roll motion damping due to moment arm difference in comparison with fin systems [5]. Quantum Maglift Company, see Figure 4, has designed rotor swing systems that have different kind of technical properties for the purpose of maximizing efficiency at various sizes of ships [6].



**Figure 4.** The ML200 Series hull unit designed for 27-35 m vessel length.

The rotors of the system are folded into the streamline of the water under the hull to decreasing speed loss and friction. Location of the rotors on the hull has an importance for efficiency, so rotors are placed almost totally in the turbulent boundary layer of the vessel. Also, manual override hand wheel can be seen mounted on the side of the swivel motor. Microprocessor technology is used to operating the system and allows to read the inclination angles for better performance.

Owing to the fact that system keeps the vessel on the level, cruise comfort and safety are paramount to engineers and it is concluded that:

- System has the benefit of providing more performance underway at slow speeds where fins would not be useful because of the enlarged fin size working at slower speeds. The longitudinal location of the rotors is also further flexible than traditional fins, letting the rotors to be located more forward or closer to the stern.

- The pair of hydraulic cylinders can be deployed and retracted, and stowed under the hull while not in operation. Stowage of the hull unit at higher sailing speeds should not let more appendage drag on hull.
- The system has a wide application area such as high speed semi displacement vessels, displacement vessels, and commercial vessels. Owners who have not specified a modern stabilization system have set up easily the stabilizer unit, and system will be chosen as a factory options in the upcoming years. However, retrofit of the system would not be preferred if the ship's hull does not suit to parking mode position of the rotors.
- Systems does not need for hydraulically operation like fins or gyroscopes. On the contrary, the fully electronic retractable system leads to smooth and silent operation. Park and drive position, RPM, and direction of rotation of the stabilization element can be controlled precisely thanks to the motion sensors, speed sensors, position sensors, and servo valves.
- As previously stated, geometric feature of the rotors take a small space which is an advantage in comparison with the fin systems. Rotorswing [5] illustrated how advanced stabilizer system which is worked with the phenomenon called Magnus effect can be operated between the 3 – 14 knots.
- The rotor's hydraulic system is equipped with automatic retract mechanism to allow the rotor to swiftly stow in case of impact during operation. While not in operation, the rotor is elegantly stowed along the hull, where it offers minimal possibility of impact and minimal effect during maneuvering conditions. In case of severe impact, half of the rotor tube will break away, in a design feature intended to sacrifice the rotor unit in order to preserve hull integrity.

#### 4. Fault Diagram of Rotor Swing Stabilizer System

This system is composed by the control unit, sensors and stabilizer system (see Figure 5). Above those components, a controller calculates set-points for rotor speed  $r_{ref}$ , referenced current for cruising speed  $c_{ref}$ , and inclination angle  $a_{ref}$ , (see Figure 6). The target of the stabilizer system is to maintain the boat's ability to stabilize itself.

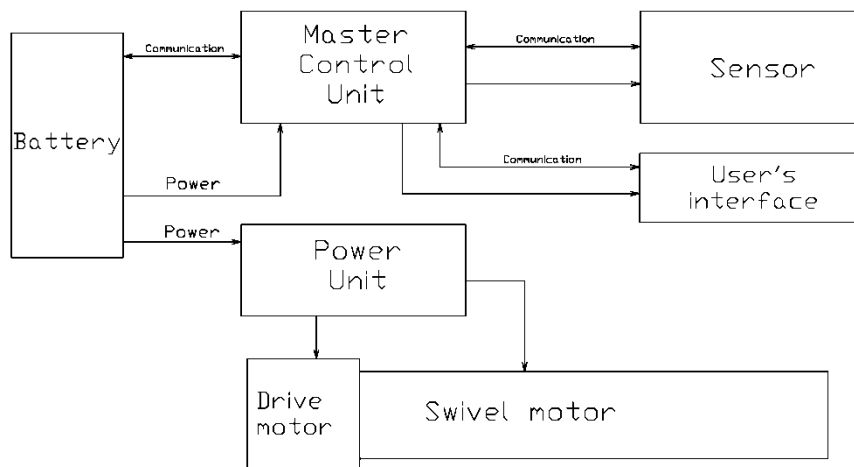
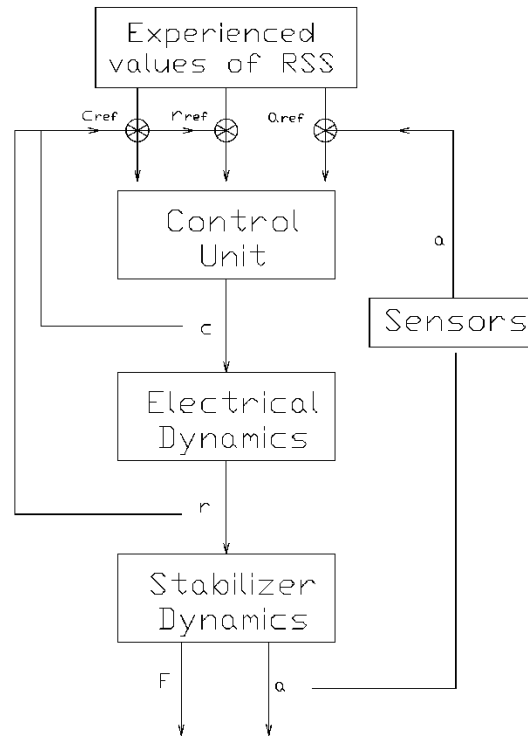

Figure 5. Block scheme of rotor swing stabilizer system.



**Figure 6.** Fault Diagram of rotor swing stabilizer system.

Experienced values of Rotor Swing Stabilizer is (a) and (r) values related the each other. On the other hand, (c) value could be changed according to operation area. By comparing the experienced values obtained from previous test or computational analysis to values measured during operation time, fault could be found.

FMEA is carried out as a fault analysis, risky parts of stabilizer system are found and solutions are offered. Design FMEA is applied according to rotor swing stabilizer's requirements, functions and components.

### 5. FMEA Methodology

Introduction of a new product or a process in today's competitive market prompt producers to reduce the failure risks to minimum. To maximize the chance for achievement, design in quality and reliability of the system should be at the early stage of the development cycle. Life cycle costs can be reduced by a successful practice of FMEA. Also, preventing the foreseen problems is less expensive than fixing them. Failure Modes and Effect Analysis is a method for examining possible problems early in the development cycle so it is possible to take action before fault occurs and enhance the reliability. Potential failure modes and effects on process can be identified by FMEA. The most important step is the foreseeing what can be wrong on the process itself. It is not possible to predict all of the faults for certain; however, an elaborate list should be ready. An FMEA should be the guide to the development of a complete set of actions that will reduce risk associated with the system, subsystem, and component or manufacturing/assembly process to an acceptable level [7]. Moreover, FMEA is an engineering examination completed by a cross functional team of subject matter experts that thoroughly



analyzes product designs or manufacturing processes, early in the product development process. Its objective is finding and correcting weaknesses before the product gets into the hands of the customer.

There are at least four recommended outline specifications that must be comprehended to follow FMEA methodology [8].

- The whole of problems are not the identical. That is the main notion in the FMEA methodology. Problems should be recognized according to their precedence.
- The customer must be known before the implementation of FMEA. The meaning of customer is thought of as the end user in general. However, a customer is the following process along with a service operation. As a matter of fact customer may be operation itself in some instances. Deciding how the customer identifies has a significant role in FMEA. For instance, customer is the end user in the design FMEA while next operation in the process is the customer in process FMEA.
- It is an obligatory decision that the function, purpose, and target must be known.
- One must be prevention oriented. The working of application an FMEA will be constant if not continuous progression is the constraining for FMEA. Customer satisfaction and/or market necessities should be the priority.

Failure Mode and Effects Analysis is a methodology designed to:

- Describe and properly understand possible failure modes and their reasons, and the impacts of failure on the system or final consumer, for a given product or process.
- Estimate the risk related with the defined failure modes, effects, causes, and prioritize problems for corrective effect.
- Describe and implement corrective actions about the most critical concerns.
- Reduce the loss of product performance to minimum
- Enhance test and verification plans in System or Design FMEAs
- Enhance process control plans in Process FMEAs
- Apprise the situation about the product design changes or manufacture process changes
- Classify important product or process characteristics
- Improve preventive maintenance plans for in-service machinery and equipment
- Improve related diagnosis methods

### **5.1 Risk Priority Number**

The term risk priority number (RPN) is numerical ranking of the risk on each possible failure mode and calculated with severity, occurrence, and detection [7].

$$\text{RPN} = \text{Severity rating} \times \text{Occurrence rating} \times \text{Detection rating}$$

RPN ranges from 1 to 1000. Engineers and designers should place importance to the failure mode which takes the highest value of RPN firstly. Then there will be some actions to correct the failure mode and RPN number will be changed, see Figure 7.

Severity is the one of the multiplier of the risk priority number. There are ranking numbers from 1 to 10 to show how severely affected the product and/or process from failure mode in accordance with selected FMEA type. Moreover severity has a feature to be relative ranking regardless of occurrence and detection. It is important to separate the potential effects of failure

as process effect and product effect when applied Process FMEAs. However, article emphasizes on Design FMEA for rotor swing stabilizer.

Occurrence is a ranking number related with the probability that the failure mode and cause will be present in the item being analyzed [7]. If the team applies the process FMEAs on the product, production stage should be considered while determination of occurrence. Occurrence ranking number is a relative value instead of absolute value, detected regardless of severity or likelihood of detection.

Detection is a ranking number related with the greatest control from the list of detection-type controls, based on the criteria from the detection scale [7]. Likelihood of detection also has relative ranking in a way that is specified with no regard to the severity and likelihood of occurrence.

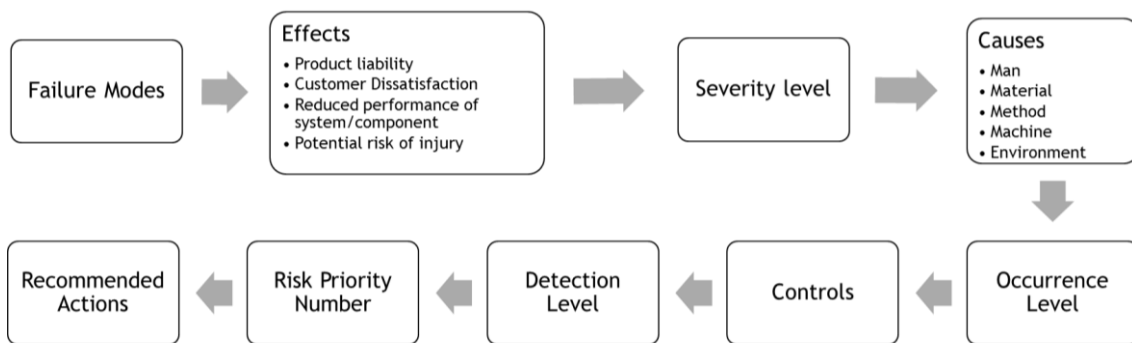

**Figure 7.** Flow diagram of FMEA.

Following to explanation of FTC and FMEA, in order to apply the methodical procedure on rotor swing stabilizer further statement is needed. In this article design FMEA is applied according to design requirements (see Appendix A), functions (see Appendix B), and components (see Appendix C) of the rotor swing stabilizer. The most important output is the risk consequences, and also severity, occurrence and detection values are detected to calculate RPN. Moreover, effects of potential failures can be reduced in design stage of the system due to the prioritization of risk consequences.

## 6. Conclusion

A technical review and bibliography listing on the historical in failure mode and effect analysis (FMEA) and fault tolerant control systems (FTC) have been submitted in this article. Within the scope of article, a simple design of a fault tolerant control system adapted to a smart rotor swing system based upon design FMEA methodology. After a brief description of rotor swing stabilizer and its working principle, a fault and risk analysis has been performed and some of applicable actions have been submitted. First of all, basic block scheme and fault diagram of the system were presented. After that, customer requirements were identified to invert them to design requirements. Failure modes of design requirements were determined according to four categories of absence, incompleteness, incorrectness, and improper occurrence. Consequently, effect analysis and severities were found. According to the requirements, functions were listed and same process steps were implemented. Finally, component failure modes and risk priority numbers were detected. The reason for choosing the design FMEA to explore the possibility of product malfunctions in the system was that there is not enough information and academic



studies about rotor swing stabilizer systems. Further investigation is required to determine the whole sub-systems and after that system FMEA will give better results [10].

Failure analysis coincides if the methodology can be applied to the every stage of the system. Listing the requirements and functions according to their risk results helps engineers to choose the components. Thanks to the earliest analyses, product can be designed with regard to consideration of the risk results. Moreover, FMEA of requirements and FMEA of functions can be documented due to complete the FMEA in the components.

For the further investigations, as an emerging technologies, a sufficiently robust controller, a robust fault diagnosis scheme and a reconfiguration mechanism can be designed as a key challenge of a proper and specific active fault tolerant control system.

### **Acknowledgement**

I would like to express my special thanks of gratitude to my thesis advisor Prof. Dr. Hakan Akyıldız who gave me the opportunity and knowledge.

### **References:**

- [1] Blanke, M., Kinnaert, M., Lunze, J., & Staroswiecki, M. “Diagnosis and Fault-Tolerant Control”, Springer-Verlag Berlin Heidelberg, 2<sup>nd</sup> Edition, 2006.
- [2] Blanke, M., Staroswiecki, M., & Wu, N. E. Concepts and methods in fault-tolerant control. American Control Conference, 2001; 2606–2620.
- [3] “RotorSwing 140”, [http://www.dms holland.com/wp-content/uploads/2013/05/Brochure-RotorSwing\\_ENG.pdf](http://www.dms holland.com/wp-content/uploads/2013/05/Brochure-RotorSwing_ENG.pdf)
- [4] “FluidsLecture 16 Notes”, <http://web.mit.edu/16.unified/www/FALL/fluids/Lectures/fl16.pdf>
- [5] Rotorswing. (2013). *The world’s first electrical Magnus effect yacht stabilizer system* [Brochure]. Retrieved from [http://www.dms holland.com/wp-content/uploads/2013/09/Leaflet-RotorSwing\\_English.pdf](http://www.dms holland.com/wp-content/uploads/2013/09/Leaflet-RotorSwing_English.pdf)
- [6] “ML200-AS Rotor Stabilizer Hull Unit”, <http://www.quantumhydraulic.com/specs/QuantumMagliftML200-AS.pdf>
- [7] Carlson, C.S. “Understanding and Applying the Fundamentals of FMEAs”. Annual Reliability and Maintainability Symposium, 2014.
- [8] Stamasis, D.H., “Failure Mode and Effect Analysis: FMEA from Theory to Execution”. 2nd Edition, 2003.
- [9] “RotorSwing boat stabilisers tested on Linssen sea trial”, <http://www.mby.com/gear/rotorswing-boat-stabilisers-tested-linssen-trial-49081>
- [10] Öztürk, D., Akyıldız H. (2016). *Fault Tolerant Control of Rotor Swing Stabilizer*. Unpublished master’s thesis, Istanbul Technical University, Istanbul, Turkey.

## Appendix:

## Appendix A: Applied FMEA procedure on requirements of rotor swing stabilizer

	Failure mode	Effect	S	Cause	O	RPN
1	System cannot damp the roll motion	The users will give up to use the system	8	System does not be opened/closed manually Rotors do not rotate Rotation direction of rotors is not correct Rotation direction of rotors is same Inclination angles do not be sensed Flow direction and velocity does not be sensed Sensors do not inform the master control unit about inclination angle Master control unit does not inform the battery to work User interface does not inform the master control unit to work Battery does not transfer the power to power unit Drive motor does not be activated Swivel motor does not be activated Rotors do not be opened Drive mode does not be activated Wire damages	3	24
2	System cannot damp the roll motion all the time while its working	The users might complain it and try to fix it	6	It takes too much time to open/close the system manually Power transfer is interrupted from battery to master control unit Power transfer is interrupted from battery to power unit Drive motor does not be activated Drive mode does not be activated Park mode does not be activated	4	24
3	System cannot produce sufficient lifting force	The users might accept it and tolerate it	6	Speed is not enough Speed is excessive Inclination angles cannot sensed correctively Rotors do not rotate enough to produce efficient lifting	4	24
4	System cannot produce any lifting force	The users will give up to use the system	8	System does not be opened/closed manually Inclination angles do not be sensed Rotors do not rotate Flow direction and velocity does not be sensed Sensors do not inform the master control unit about inclination angle Master control unit does not inform the battery to work User interface does not inform the master control unit to work Battery does not transfer the power to power unit Drive motor does not be activated Swivel motor does not be activated Rotors do not be opened Drive mode does not be activated Wire damages Rotation direction of rotors is not correct Rotation direction of rotors is same	2	16
5	Fully electrically driven system cannot work	The users will give up to use the system	8	Wire damages	6	48
6	Fully electrically driven system only works at some sequences	The users might complain it and try to fix it	7	Wire damages	6	42
7	Fully electrically driven system send the wrong commands	The users might complain it and try to fix it	7	Inclination angles cannot sensed correctively Flow direction and velocity does not be sensed correctively Sensors do not inform correctly the master control unit about inclination angle Depth and port distance do not be sensed correctively	3	21

Appendix A (continue): Applied FMEA procedure on requirements of rotor swing stabilizer

	<b>Failure mode</b>	<b>Effect</b>	<b>S</b>	<b>Cause</b>	<b>O</b>	<b>RPN</b>
<b>8</b>	Stabilizer is not folding into streamline on park mode / opening on drive mode	The users might complain it and try to fix it	7	Drive mode does not be activated Park mode does not be activated Drive motor does not be activated Swivel motor does not be activated Battery does not transfer the power to power unit User interface does not inform the master control unit to work Master control unit does not inform the battery to work Battery does not transfer the power to master control unit Master control unit does not inform the sensors to work Inclination angles do not be sensed Sensors do not inform the master control unit about inclination angle Sensors do not inform correctly the master control unit about inclination angle	3	21
<b>9</b>	Stabilizer cannot open/close totally	The users might complain it and try to fix it	7	It takes too much time to open/close the system manually Power transfer is interrupted from battery to master control unit Power transfer is interrupted from battery to power unit Drive motor does not be activated Drive mode does not be activated Park mode does not be activated	3	21
<b>10</b>	It takes long time to open/close stabilizers	The users might accept or tolerate it	5	It takes too much time to open/close the system manually Power transfer is interrupted from battery to master control unit Power transfer is interrupted from battery to power unit Drive motor does not be activated Drive mode does not be activated Park mode does not be activated	5	25
<b>11</b>	User cannot open/close stabilizer	The users will give up to use the system	7	System does not be opened/closed manually Rotors do not rotate Rotation direction of rotors is not correct Rotation direction of rotors is same Inclination angles do not be sensed Flow direction and velocity does not be sensed Sensors do not inform the master control unit about inclination angle Master control unit does not inform the battery to work User interface does not inform the master control unit to work Battery does not transfer the power to power unit Drive motor does not be activated Swivel motor does not be activated Rotors do not be opened Drive mode does not be activated Wire damages	4	28
<b>12</b>	User meet difficulties to open/close stabilizer (stabilizer is stuck)	The users might complain it and try to fix it	6	Power transfer is interrupted from battery to power unit Drive motor does not be activated	3	18
<b>13</b>	User meet difficulties to send correct command	The users might complain it and try to fix it	6	User interface does not inform the master control unit to work	5	30

	Function failure modes	Effects	S	Causes	O	RPN
F1	System does not be opened/closed manually	System cannot produce any lifting force	8	User interface is damaged Master control unit is damaged Battery is damaged Battery losses efficiency Power unit is damaged	3	24
	It takes too much time to open/close the system manually	Users have to wait some time for roll damping	5	User interface is not compatible	3	15
F2	Inclination angles do not be sensed	System cannot produce any lifting force	8	Motion sensor is damaged Master control unit is damaged	3	24
	Inclination angles cannot sensed correctively	System produce inadequate lift force	7	Motion sensor losses efficiency	3	21
F3	Rotors do not rotate	Extra resistance	8	Drive motor is damaged Power unit is damaged Battery is damaged Master control unit is damaged User interface is damaged	2	16
	Rotors do not rotate enough to produce efficient lifting	System produce inadequate lift force	7	Speed sensor losses efficiency	3	21
F4	Flow direction and velocity does not be sensed	Extra resistance	8	Motion sensor is damaged Master control unit is damaged	2	16
	Flow direction and velocity does not be sensed correctively	Rotors cannot rotate in correct way	8	Motion sensor losses efficiency	3	24
F5	Rotation direction of rotors is not correct	Roll motion of ship increases	8	Position sensor losses efficiency	3	24
	Rotation direction of rotors is same	Roll motion of ship increases	8	Position sensor losses efficiency	3	24
F6	Speed is not enough	System produce inadequate lift force	4	Speed sensor losses efficiency	3	12
	Speed is excessive	System produce inadequate lift force	4	Speed sensor losses efficiency	3	12
F7	Sensors do not inform the master control unit about inclination angle	System cannot produce any lifting force	8	Motion sensor is damaged Master control unit is damaged	2	16
	Sensors do not inform correctly the master control unit about inclination angle	System produce inadequate lift force	4	Motion sensor losses efficiency	3	12
F8	Master control unit does not inform the sensors to work	System produce inadequate lift force	4	Sensors are damaged Master control unit is damaged	2	8

Appendix B (continue): Applied FMEA procedure on functions

	<b>Function failure modes</b>	<b>Effects</b>	<b>S</b>	<b>Causes</b>	<b>O</b>	<b>RPN</b>
<b>F9</b>	Battery does not transfer the power to master control unit	Users cannot command to the system	4	Battery is damaged Master control unit is damaged	2	8
	Power transfer is interrupted from battery to master control unit	Users have to wait some time to command to the system	3	Battery losses efficiency	3	9
<b>F10</b>	Master control unit does not inform the battery to work	System cannot produce any lifting force	8	Master control unit is damaged	2	16
<b>F11</b>	User interface does not inform the master control unit to work	System cannot produce any lifting force	8	User interface is damaged Master control unit is damaged	2	16
<b>F12</b>	Battery does not transfer the power to power unit	System cannot produce any lifting force	8	Battery is damaged	2	16
	Power transfer is interrupted from battery to power unit	Users have to wait some time for roll damping	3	Battery losses efficiency	3	9
<b>F13</b>	Drive motor does not be activated	System cannot be retracted/opened	7	Power unit is damaged	2	14
<b>F14</b>	Swivel motor does not be activated	Rotors cannot be rotated	8	Power unit is damaged	2	16
<b>F15</b>	Rotors do not be opened	System cannot produce any lifting force	8	Drive motor is damaged Power unit is damaged Battery is damaged Master control unit is damaged	3	24
<b>F16</b>	Rotors do not be closed	Extra resistance	8	Drive motor is damaged Power unit is damaged Battery is damaged Master control unit is damaged	3	24
<b>F17</b>	Depth and port distance do not be sensed any	Rotors can be damaged	7	Distance sensor is damaged Master control unit is damaged	3	21
	Depth and port distance do not be sensed correctively	Rotors can be damaged	7	Distance sensor losses efficiency	3	21
<b>F18</b>	Drive mode does not be activated	System cannot produce any lifting force	8	User interface is damaged	4	32
<b>F19</b>	Park mode does not be activated	Extra resistance	8	User interface is damaged	4	32

Appendix C: Completion of documentation for components of rotor swing stabilizer

Component	Failure mode	Effects	S	Causes	O	Control	D	RPN	Recommended actions
Battery	Battery is damaged	The system cannot work	8	Positive grid growth Positive grid metal corrosion Negative grid shrinkage Buckling of plates	3	None	10	240	The vessel equipped with the rotor swing stabilizer should go back to port
Battery	Battery losses efficiency	The system meets difficulty for power transmission	6	Expansion and contraction that occurs during the discharge and charge cycles Deep discharges Heat Vibration Fast charging Overcharging	5	Regularly battery voltage control	5	150	First check the wires
Distance Sensor	Distance sensor is damaged	Rotors will be damaged by sea bottom or port	7	Overheating of other components Battery dies	3	Reinforced control system	5	105	Replace
Distance Sensor	Distance sensor losses efficiency	Rotors might be damaged by sea bottom or port	7	Getting dirty	6	Reinforced control system	3	126	Clean it
Master Control Unit	Master control unit is damaged	System cannot work	8	Overheating Corrosion	3	None	10	240	First check the battery
Motion Sensor	Motion sensor is damaged	The system cannot work in accordance with inclination angles	7	Overheating of other components Battery dies	3	Reinforced control system	5	105	Replace
Motion Sensor	Motion sensor losses efficiency	The system meets difficulty to sense the inclination angles	6	Getting dirty	6	Reinforced control system	3	108	Clean it
Position Sensors	Position sensor is damaged	Rotor's position cannot be arranged	8	Overheating of other components Battery dies	3	Reinforced control system	5	120	Replace
Position Sensors	Position sensor losses efficiency	The system meets difficulty to adjust the rotor's position	7	Getting dirty	6	Reinforced control system	3	126	Clean it



Appendix C (continue): Completion of documentation for components of rotor swing stabilizer

Component	Failure mode	Effects	S	Causes	O	Control	D	RPN	Recommended actions
Power Unit	Power unit is damaged	Drive and swivel motor cannot work	8	Overheating Corrosion Spike of voltage Abnormal high-current power	3	None	8	192	First check the battery
Speed Sensors	Speed sensor is damaged	Rotor's speed cannot be arranged	6	Damages on wiring Overheating of other components Battery dies	3	Reinforced control system	5	90	Replace
Speed Sensors	Speed sensor losses efficiency	The system meets difficulty to adjust the rotor's speed	6	Attraction with metal particles Getting dirty	6	Reinforced control system	3	108	Clean it
Users Interface	User interface is damaged	The system cannot opened /closed	8	Direct sunlight Pulling or twisting the cord by user Using objects with sharp end to press the buttons Getting wet	5	Master control unit	2	80	First check the master control unit
Users Interface	User interface is not compatible	The users meet difficulty to control the system	7	Malfunction on master control unit User error	5	Master control unit	3	105	First check the master control unit
Drive Motor	Drive motor is damaged	Rotors cannot open/close	8	Electrical overload Low Resistance Over heating Dirt, Moisture, Vibration	4	Reinforced control system and motor controller against probable faults	2	64	First check the power unit
Swivel Motor	Swivel motor is damaged	Rotors cannot turn	8	Electrical overload Low Resistance Over heating Dirt, Moisture, Vibration	4	Reinforced control system and motor controller against probable faults	2	64	First check the power unit
Wires	Wires are damaged	Electrical equipment corrodes Stray current damage Insulations of wires Chronic battery drain	9	Electrical equipment gets wet Leaks, salt air, humidity High temperature and vibration Paintings of the wire insulations High resistance	6	Visual	3	162	Power off the system

