





FRONT- END MODULE DEVELOPMENT FOR A LIGHT COMMERCIAL VEHICLE

Ayça KÜÇÜKOĞLU *
Ali Ozan BAĞRIYANIK *
İlker BAHAR *
Fatma SİRKECİ *
Yavuz Emre YAĞCI **

Received: 10.05.2020; revised: 05.11.2020; accepted: 05.11.2020

Abstract: CO₂ emission targets became a crucial obstacle for vehicle producers. In order to overcome this problem, weight reduction potentials are getting more and more critical. In this study, for a light commercial vehicle, a glass fiber reinforced thermoplastic front-end structure has been analyzed. At first, a fully plastic draft design is analyzed and compared with the current metal structure. After that, a topology volume is extracted from the existing vehicle structure, and topology optimizations have been carried out according to the modal and static loading performance targets. Different optimization parameters have been investigated to decide the best solution in terms of performance and weight. Load paths and optimum design are calculated by topology results. Due to the packaging problems with the radiator and headlamp, optimization volume is modified, and the new topology volume and optimizations are completed. Based on the topology results, a feasible design is prepared, and detailed non-linear analyses are started. After the non-linear analyses, free size optimization is applied to the ribs of the part. In this study, a feasible preliminary design at the same performance with less weight respect to the current metal version is completed.

Keywords: Front-End Module, Abaqus, Optistruct, Topology Optimization, Weight Reduction, Metal Replacement.

Hafif Ticari Bir Araç İçin Ön Burun Taşıyıcı Modül Geliştirme

Öz: CO₂ emisyon hedefleri araç üreticileri için aşılması gereken en önemli engellerin başında gelmektedir. Hedefe ulaşmak için gerekli potansiyeller biri olan araç hafifletmenin önemi gün geçtikçe artmaktadır. Bu çalışmada, hafif ticari bir araç için cam elyaf takviyeli termoplastik ön burun taşıyıcı modülü sonlu elemanlar analizleri kullanılarak geliştirilmiştir. İlk aşamada, geliştirilen termoplastik tasarımın analizleri gerçekleştirilmiş ve mevcut durumda kullanılan metal yapı ile karşılaştırılmıştır. Daha sonra, mevcut yapıdan paketleme ile montaj kısıtları dikkate alınarak bir topoloji dizayn hacmi çıkarılmıştır. İlgili hacim kullanılarak doğal frekans hedefleri ile yapısal performans kriterleri dahilinde topoloji optimizasyonları gerçekleştirilmiştir. Optimizasyonlar sırasında performans ve ağırlık açısından optimum çözüme

* Tofaş Türk Otomobil Fabrikası A.Ş., Ar-GE, İstanbul Cad. No: 574 16110, Bursa, Türkiye

** Farplas Otomotiv A.Ş., Ar-Ge, TOSB Otomotiv (OSB) Mah. 3. Cad. No:11/2 41420, Çayırova-Kocaeli, Türkiye

İletişim Yazarı: Ayça Küçükoglu (ayca.kucukoglu@tofas.com.tr)

ulaşabilmek için farklı parametrelerin etkisi araştırılmıştır. Topoloji optimizasyon sonuçları kullanılarak optimum tasarım ve yük yolları belirlenmiştir. Radyatör ile far arasında değişen paketleme kısıtları nedeniyle optimizasyon hacmi değiştirilerek yeni bir topoloji dizayn hacmi oluşturulmuş ve topoloji optimizasyonları tekrarlanmıştır. Optimizasyon sonuçlarına göre yeni bir tasarım oluşturulmuştur. Bu tasarım kullanılarak doğrusal olmayan yapısal analizler gerçekleştirilmiştir. Analizlerin ardından yeni tasarımdaki federlerde kalınlık optimizasyonu yapılmıştır. Bu çalışmada, mevcut metal versiyonuna göre daha hafif olan ve aynı performansta sahip termoplastik bir ön burun taşıyıcı modülü geliştirilmiştir.

Anahtar Kelimeler: Ön Burun Taşıyıcı Modül, Abaqus, Optistruct, Topoloji Optimizasyonu, Ağırlık Azaltma, Metal Değişirme.

1. INTRODUCTION

Every year the fuel consumption and CO₂ emission targets are getting more and more challenging to achieve. However, for vehicle manufacturers, the aim is not only to reduce vehicle weight simply but also to do it with the minimum cost up. To reach weight reduction targets with a manageable cost-up, topology optimization and metal replacement have become very popular in the automotive industry. By developing optimized parts with topology optimization, engineers are trying to throw away the unneeded material to reduce weight. Furthermore, metal replacement is also one of the critical methods for weight reduction. By changing the material and design, it is possible to develop parts that have the same performance at much less weight.

There are various applications of metal replacement with plastics as in this study, both metal replacement and topology optimization is used to substitute a complicated metal assembly, which consists of headlamp traverse, vertical links, and radiator traverse with a one-part, lightweight plastic Front-End Module (FEM).

2. FRONT END MODULE

The current FEM, which is formed in FEE 220 BH metal structure, is used headlamp travers that carries the headlamp, radiator, engine hood lock, engine hood release cable, front bumper, and air inlet brackets. Headlamp Travers is mounting on the vertical link and upper rail. Radiator Travers carries the radiator, engine undercover, and front bumper. In models where headlamp travers and radiator travers are used, the parts mounted on these parts separately on the vehicle. The material of the components is sheet metal, and it consists of 18 parts in total.

Metal sheet assemblies have been used traditionally for the FEM, but now many Original Equipment Manufacturers (OEM's) have seen an advantage in reducing part quantities and weight by changing over to composite. OEM's are also showing interest in a lightweight material to reduce the total weight and cost of the vehicle. Nowadays, more emphasis is on full composite FEM to improve performance, weight, ratio, and also simplify manufacturing (A2mac1, 2019).

The FEM carries on all the parts of the headlamp travers and the radiator travers. FEM will do the function of all the sheet metal components. It can be assembled into a module in a preparation line, allowing for a one-time installation. The Full plastic FEM will be mounted to the vertical link and the headlamp brackets on the body shop. Long glass fiber reinforced polymers have been used for a FEM as a unique part. The other components used during the assembly of this part are sheet metal. Figure 1 shows the exploded view of the front of the vehicle with FEM (Droste et al., 2003, Koch et al., 1999, Naughton et al., 2002, Optistruct, 2017).

FEM is also designed to structural requirements such as headlamp mounting stiffness, engine hood lock stiffness, bumper connection stiffness, pedestrian safety lower leg support, and modal analysis. Structurally, it also provides stiff support to radiators or headlamps. Engine hood lock, headlamp mountings, pedestrian safety lower leg support needs both strength and stiffness (Droste et al., 2003, Koch et al., 1999).



Figure 1:
Exploded view of FEM

3. LOADING CONDITIONS AND 1st DESIGN ANALYSES

3.1. Loading Conditions

The front structure of the current vehicle consists of headlamp travers, radiator travers, and vertical links. There are many important components attached to these parts, such as headlamps, front bumper, engine hood lock, engine hood anti-vibration buffers, and radiator. Because of that, there are many crucial performance targets of the FEM. For the preliminary design, some of the static loading conditions below have been investigated;

- ✓ Modal Analyses
- ✓ Engine Hood Lock Stiffness (500N Vertical) and Misuse Analyses (1500N Vertical)
- ✓ Bumper Connection Stiffness Analyses (200N Vertical)

At first, based on current metal design, a draft plastic design is created and analyzed. According to modal analyses and engine hood lock stiffness analyses, the design was out of the target. All the targets for the new design were as much as current metal design, at least. It can be easily seen from Figure 2 that the upper side of the plastic structure has an individual mode. So, it appeared to be unacceptable behavior for modal analyses (Sobieszczanski-Sobieski et al., 2001).

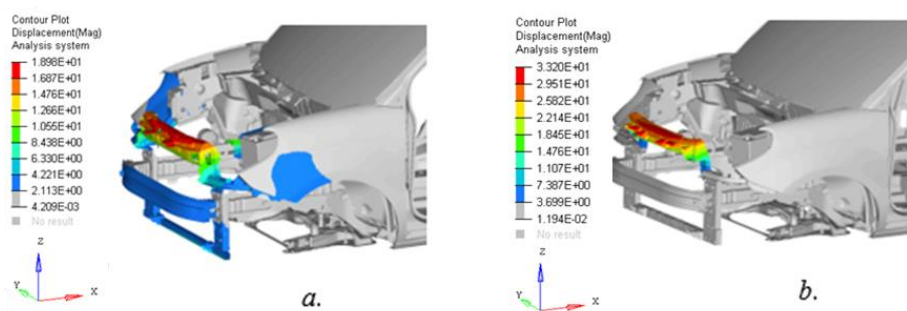

Figure 2:
a. Modal analyses result of current metal design b. Draft plastic design

3.2. Topology Analyses

Nowadays, much more advanced techniques are used, and with the help of the finite element method, it could be applied to complex problems. Optimization, one of these tools, is concerned with maximizing the utility of a structure under a given objective. In structural optimization, “the best structural” design is selected regarding three categories: size optimization, shape optimization, and topology optimization. The application of topology optimization is getting the best material distribution in a structure that is the most favorite one. Mainly, weight savings are managed as a consequence of the utilization of these methods. Many applications can be found in the literature (Bendse and Sigmund, 2004, Chiandussi et al., 2004, Fujii et al., 2004, Duddeck, 2008, Volz and Zimmer, 2007). While shape and size optimization methods are interested in optimizing thicknesses and boundaries of the parts, aim of the topology optimization is related with getting the optimized design by using whole geometry domain.

Topology optimization is a mathematical method that material distribution in a structure within a given design space, under a given set of loading, boundary conditions and also constraints with the goal of maximizing the performance of the system. In this paper, density method used in Altair’s Optistruct software. In the optimization model construction, the density of each element is defined as a continuous design variable. The material densities can take values between zero and one. This algorithms which handle large amounts of continuous variables and multiple constraints are available but the material properties have to be modelled in a continuous. This is done through interpolation. One of the most implemented interpolation methodologies is the Solid Isotropic Material with Penalisation Method (SIMP). According to SIMP, there is a relation between elastic modulus (E) and density (ρ) with a penalty factor (p) as in following formula

$$E = E_0 \left(\frac{\rho}{\rho_0} \right)^p \quad (1)$$

If the final density of the element is close to 0, this element can be excluded from design volume. Similarly, if the optimized density is close to 1, the element is needed to satisfy the objective target. (Höke and Bozca, 2019; Cavazzuti et al., 2011).

Two common objectives to be minimized are the compliance (C) and the volume (V). A possibility to maximize the global stiffness of a structure is to minimize its compliance. The compliance is therefore defined as the equivalent strain energy of the finite element solution which yields higher stiffness when minimized. The compliance is defined as

$$C(p) = f^T u \quad (2)$$

where u solves the equilibrium equation below

$$K(p)u = f \quad (3)$$

where $K(p)$ is

$$K(p) = \sum_{e=1}^{nel} \rho^p K_e^0 \quad (4)$$

K_e^0 is the elemental stiffness matrix with the initial stiffness tensor E^0 . To prevent the optimized structure from ending up with the full design volume as a result when searching for its maximum structural stiffness, we need to impose a volume constraint. If a gradient based approach is used, derivatives with respect to $C(\rho)$ are re-evaluated.

Another possibility is to minimize the volume;

$$V(p) = \sum_{e=1}^{nel} \rho^p V_e^0 \quad (5)$$

where V^0 is the initial volume. To prevent the optimization from minimizing all material, we need to impose a constraint for maximum displacement or effective stress. The optimization task is carried out with respect to the objective function and constraints. However, if the objective function is formulated with respect to volume or weight, derivatives are evaluated with respect to the constraints (Larsson, 2016).

After the modal and stiffness analyses, topology optimization was performed for design improvement to reach targets. Design volume for topology analyses, which is created considering by packaging restrictions, clearances, and holes for bumper connections and lock mechanism, is filled with 3D tetrahedral elements, as presented in Figure 3.

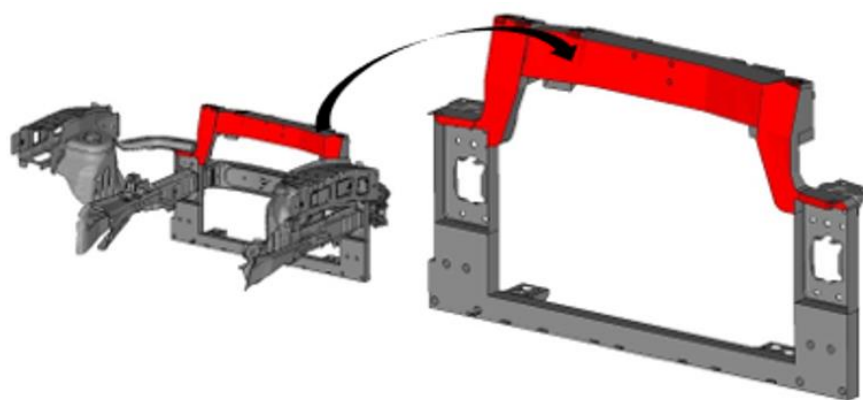

Figure 3:
Design space extraction (red area)

Loading condition (500N Vertical- applied from Lock Mechanism point) that represents the stiffness of locking for engine hood is used in optimization. Also, under this loading condition, the displacement value of the current metal design is defined as a constraint for the plastic design.

1-plane Symmetry constraint is used during the optimization. Also, minimum- maximum member size options enabled. Single draw-type direction, which is essential for molding, is used as a manufacturing constraint. Topology optimization is executed by fifty-five iterations with all constraints satisfied, which is shown in Figure 4.



Figure 4:
Optimization results of first design volume under various iso-contour

As a second idea, the design volume is enlarged, and the total radiator area was filled as a topology design volume. The same manufacturability and loading constrain as in the previous analyses are used for topology optimizations, as presented in Figure 5.

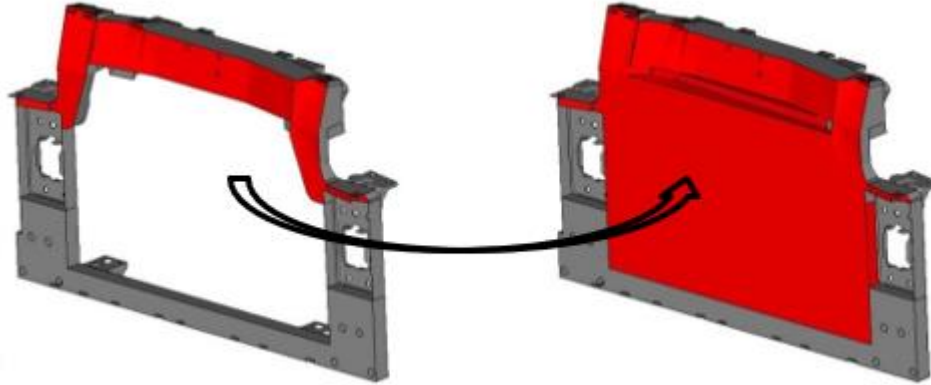

Figure 5:
Enlarged design volume

It can easily be seen that topology result satisfies the vertical stiffness target for the lock loading condition. In addition, when the results are investigated, it's also clearly seen that the right and left necks should be enlarged. Furthermore, thicker vertical ribs than the previous result are needed, as shown in Figure 6.

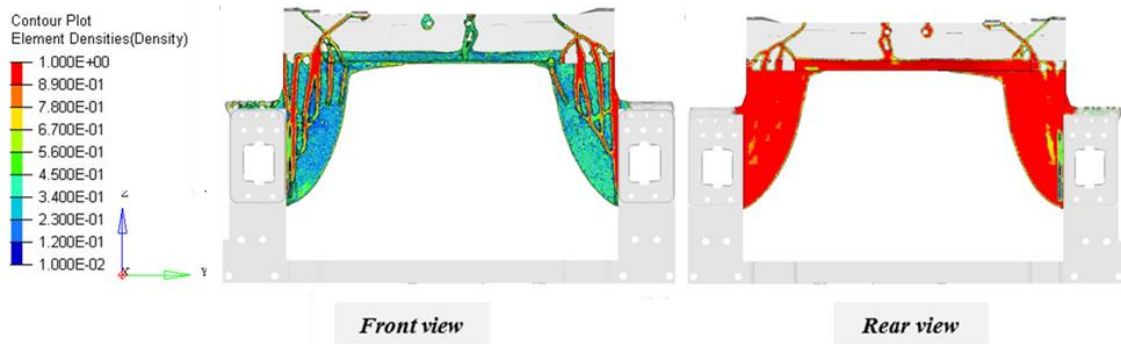

Figure 6:
Optimization result of second design volume

The draft design, which is output from topology optimization, exported in .stl format to create the new CAD. According to the topology optimization results, new CAD data is generated. Due to packaging restrictions and clearance tolerances also some manufacturing constraints such as molding, some of the results of the topology optimization could not be applied to the model. For the draft plastic design, which is presented in Figure 7, the weight reduction is observed almost 50%.

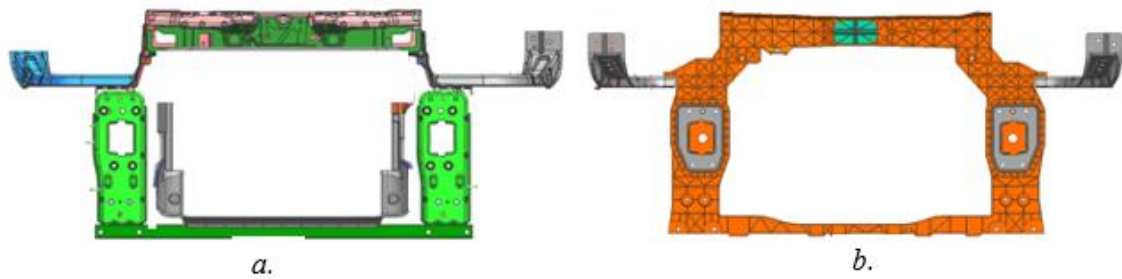

Figure 7:
a. Comparing current metal design b. Draft plastic design

According to the vertical lock stiffness results, the FEM structure was still out of the target. On the other hand, the new FEM is planned to apply to the current product vehicle, surrounding parts that are used for connecting the FEM to BIW cannot be changed. As a result, the showed design which comes from topology optimizations, could not be applied to the FEM structure directly.

To reach the stiffness of the locking target, a free-size optimization is applied on the ribs of the FEM structure. After that, unneeded and crucial ribs were detected. Finally, some mass added because of thicker ribs, which are results, in Figure 8, of free-size optimization to achieve the stiffness target of the FEM structure.

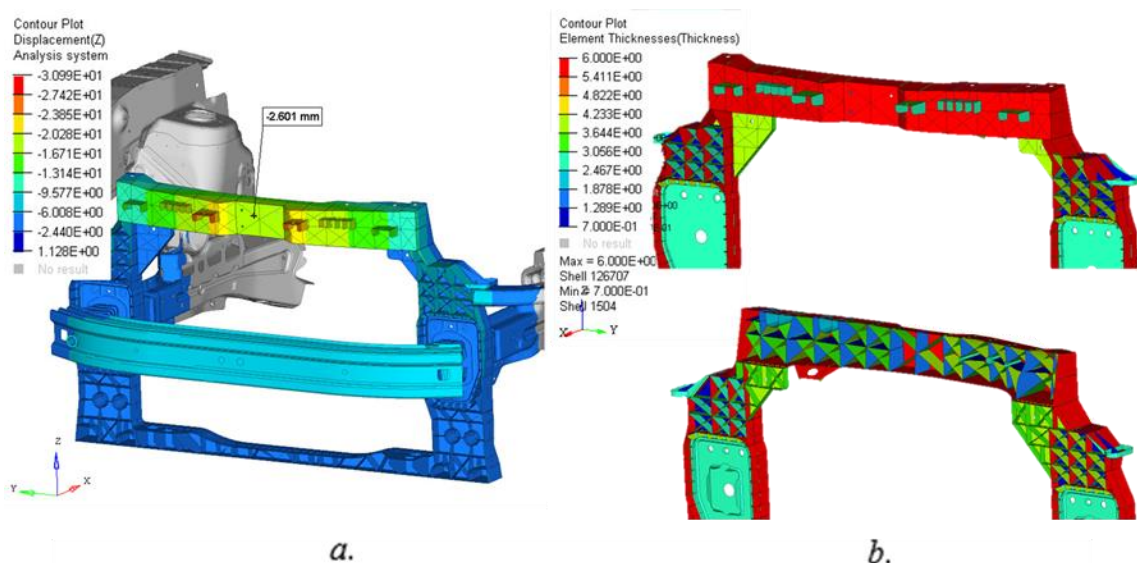

Figure 8:
*a. An example of engine hood lock stiffness analysis
 b. Thickness distribution after free-size optimization for the ribs*

Due to the injection concern, the number of ribs inside the upper frame of the FEM was needed to be reduced. Because of that, for the top frame, another topology loops were made. In these analyses to reduce the number of ribs in the upper frame volume created with mesh refinement. Also, different manufacturability constraints were investigated, such as on minimum and maximum member size, symmetry on design, and draw direction for production.

After several loops of topology optimizations, the rib structure for the upper frame, which is shown in Figure 9, was decided. As a result, not only stiffer but also lighter and more simple structure is created comparing the current metal design.

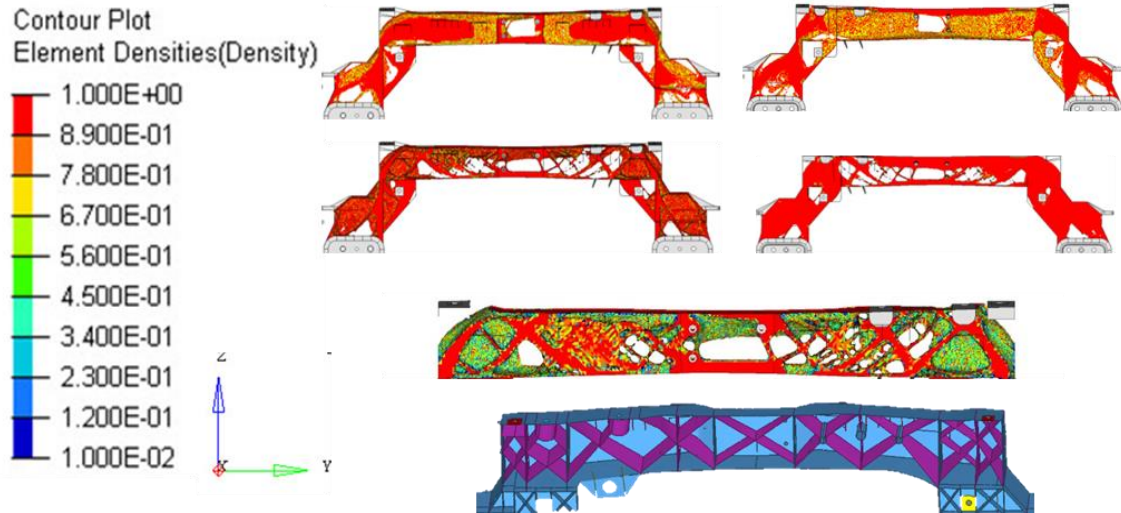

Figure 9:
New rib structure after topology optimization loops

4. CONCLUSION

In this study, for a light commercial vehicle, a glass fiber reinforced thermoplastic FEM structure has been created instead of a metal structure by using optimization methods such as topology, free-size, etc.

Mostly the parts selected for metal replacement do not need any stiffness and strength requirements. However, with the reinforced plastics, it was possible to replace metal with plastic.

Topology optimization was an essential tool for metal replacement by plastic. Because the design would have to change to meet the same performance with the metal design and topology optimization would guide the plastic design. It provided not only more simple and lighter design but also stiffer. Also, it helped in developing draft designs without any over-engineering.

In summary,

- ✓ The new plastic FEM structure, which meets the same performance with the metal design, has been created.
- ✓ The weight reduction was almost 50% comparing to the current metal design.
- ✓ Parts used in the structure number reduced eighteen pieces to seven pieces. So, the more simple design achieved.

ACKNOWLEDGMENTS

This study is supported by TÜBİTAK (The Scientific and Technical Research Council of Turkey) with 3160366 Project Number. We would like to thank TÜBİTAK for its financial support throughout the project.

REFERENCES

1. A2mac1, *Automotive Benchmarking*, (2019). Web address: <http://www.a2mac1.com>, Saarbrücken.
2. Bendse, M. P. and Sigmund, O. (2004) *Topology optimization: theory, methods and applications*, Springer, New York. doi: 10.1007/978-3-662-05086-6
3. Cavazzuti, M., Costi, D. and Baldini, A., (2011) Automotive Chassis Topology Optimization: a Comparison Between Spider and Coupé Designs, *Conference: World Congress on Engineering 2011 - The 2011 International Conference of Mechanical Engineering, London, UK, Volume: Proceedings of the World Congress on Engineering 2011 Vol III*, July 2011.
4. Chiandussi, G., Gaviglio, I. and Ibba, A. (2004) Topology optimisation of an automotive component without final volume constraint specification, *Advances in Engineering Software*, 35, 609–617. doi:10.1016/j.advengsoft.2003.07.002
5. Droste, A., Naughton, P., Bowser, B., Röttger, J., Burr, S., Imam, O., Zeitler, M., Heuft, Th. and Cawley, A. (2003) Bonded metal-plastic composite structures — the future of lightweight, cost-effective performance, *SPE Automotive Composites Conference*, Michigan.
6. Duddeck, F. (2008) Multidisciplinary optimization of car bodies, *Structural and Multidisciplinary Optimization*, 35, 375-389. doi:10.1007/s00158-007-0130-6
7. Fujii, T., Shibuya, S., Sato, Y., Jankowski, U., Müller-Bechtel, M. and Schneider, P. (2004) New Body in White Concept through Topology Optimisation, *Verein Deutscher Ingenieure (VDI)- Berichte*, Nr. 1846.
8. Höke, Ö. and Bozca, M. (2019) Topology Optimisation of Engine Cross Members for Lightweight Structure in Light Commercial Vehicles, *International Journal of Precision Engineering and Manufacturing*, doi:/10.1007/s12541-019-00228-4.
9. Koch, B., Knözinger, G., Pleschke, T., and Wolf, H J. (1999) Hybrid-Frontend als Strukturbauteil, *SpringerLink*, In: KU Kunststoffe, Carl Hanser Verlag, München, März, S. 82–86. doi: 10.1007/BF03221756
10. Larsson, R., (2016) Methodology for Topology and Shape Optimization: Application to a Rear Lower Control Arm, *Master's thesis in Applied Mechanics*, Department of Applied Mechanics, Chalmers University of Technology, Göteborg, Sweden.
11. Naughton, P., Röttger J., and Bowser, B. (2002) A new approach to hybrid front-end systems, SAE 2002-01 1229 presented at *SAE International Congress & Exposition*, Detroit, MI, USA, March. doi: 10.4271/2002-01-1229.
12. Optistruct is part of the Altair 2017: *Users guide*. Altair Engineering, Inc., Troy, Michigan.
13. Sobieszczanski-Sobieski, J., Kodiyalam, S. and Yang, R.Y. (2001) Optimization of a car body under constraints of noise, vibration, and harshness (NVH), and crash, *Structural and Multidisciplinary Optimization*, 22, 295–306. doi:10.1007/s00158-001-0150-6
14. Volz, K.H. and Zimmer, H. (2007) Optimizing Topology and Shape for Crashworthiness in Vehicle Product Development, *IABC International Automotive Body Congress*, Berlin.

