

## Effect of Dielectric Substrate Parameters Which Dimensions of Lens and Distance From Antenna on The Gain Enhancement of Microstrip Antenna with Metamaterial

Bülent URUL<sup>1\*</sup>

**ABSTRACT :** In this study, it was aimed to determine the effect of dielectric substrate parameters which dimensions of lens and distance from antenna used as lens layer in front of antenna on antenna gain for the 2.45 GHz Wifi frequency band and calculate the effect of dielectric substrate on increasing the gain of classical microstrip antenna by using metamaterial lens layer (Square split ring resonator). For this purpose, a conventional microstrip antenna with a center resonant frequency of 2.45 GHz was first designed with the help of an electromagnetic simulation program. Then, the dielectric lens layer's size and distance from the antenna parameters were optimized and a maximum gain of 16% was obtained. In addition, it was determined that the dielectric lens layer size had more effect on increase of gain than the distance between antenna and lens layers. Then, the dielectric lens layer,  $5\lambda / 16$  antenna size and  $\lambda / 4$  antenna distance which selected randomly, was designed and placed as a lens in front of the antenna (without using metamaterial). It was observed that the dielectric lens layer had an effect of antenna gain of about 7% for the single layer and 22% for the double layer. A square split ring resonator-shaped metamaterial lens layer with the same parameters as the resulting dielectric lens layer was then designed and placed in front of the conventional microstrip patch antenna for the 2.45 GHz Wifi frequency. It was observed that the lens layer with metamaterial increased the gain of the antenna by about 22% by placing it in single layer and 87% by placing it in double layer in front of the conventional microstrip antenna.

**Keywords:** Metamaterial, substrate parameters, microstrip antenna

<sup>1</sup> Bülent Urul (**Orcid ID:** 0000-0003-2656-2450), Isparta Uygulamalı Bilimler University, Vocational School of Technical Science, Electronics and Automation Department, Isparta, Turkey

\*Sorumlu Yazar/Corresponding Author: Bülent Urul, e-mail: bulenturul@isparta.edu.tr

**Geliş tarihi / Received:** 11-01-2020

**Kabul tarihi / Accepted:** 14-03-2020

## INTRODUCTION

With the developing technologies, microwave antennas play a wide range of roles in our lives and many studies are being made by engineers in this direction. A lot of studies about microwave antennas have been added to the literature in recent years, such as more compact and high gain antenna designs, microwave absorbance and a smaller radar cross-sectional area of antenna (Tütüncü, 2019a; Tütüncü, 2019b). Especially, Wi-fi technology is the most widely used technology in everyone's life. Today's people can connect their phones, computers and televisions to the internet every day thanks to this technology and communicate with the world. There are also some standards for Wi-fi technology. For this, the IEEE 802.11b / g / n standard at 2.4 GHz or the IEEE 802.11ac standard at 5 GHz is available. However, with new technologies, devices are required to operate in a smaller size, higher gain and a wide frequency range. This forces the researchers to perform different antenna studies. It is desirable that the antennas being constructed have high gain and directivity and that these antennas have a wide bandwidth. Due to their small size, light weight, low cost, easy design and production, microstrip antennas are frequently used in many industries, medical and communication devices for this purpose. However, the low bandwidths and low gain levels of these antennas have been shown to be disadvantages. In order to overcome these deficiencies of classical microstrip antennas(CMA), many studies have been made with new techniques in the literature and new high gain antennas are being studied by researchers every day in this direction. One way to increase antenna gain is to use antennas with metamaterial structures, which are artificial materials with a negative refractive index which are called metamaterials(MM).

MM structures were first introduced by Veselago in 1968 (Veselago, 1968). Accordingly, if the electrical permittivity and magnetic permeability of a material is negative, there are a negative refraction, and this inverse refraction causes the electromagnetic focus to be collected at a point rather than scattering in different directions and weakening. Therefore, the antenna directivity and gain can be increased if MM structures are used on antenna structures or as electromagnetic lenses. In recent years MM has been used in many studies by researchers because of these unnatural negative refraction properties of structures. For example, in a study conducted by Esmail (Esmail et al, 2019), a dipole antenna was designed in the 3.5GHz frequency band (5G technology) and then a metamaterial structure called ASSR was placed on the antenna substrate in the same plane with the antenna and the angle of deflection was increased and the antenna gain was increased. In another study by Jie Lei (Lei, 2018), it has been shown that the antenna bandwidth can be increased significantly by adding SRR metamaterial structures to the ground plane of the microstrip antenna substrate. In 2014, DadGarpour showed that by placing a metamaterial lens layer in front of an antenna structure called a bow tie antenna, the antenna main beam could be directed in a desired direction and accordingly the antenna performance could be improved (Dadgarpour et al, 2014). In addition to these studies, there are also several antenna studies using MM (Kumar A and Kumar VD, 2013; Rahman et al, 2018; Arayeshnia et al, 2019; Singh HS et al, 2019; Singh M, 2019).

In this study, it is aimed to investigate the effect of dielectric substrates on antenna gain. For this purpose, dielectric substrate parameters were examined. In this study, firstly, conventional microstrip antenna (CMA) was designed. Then, the effect of dielectric lens layer dimensions on antenna gain was investigated by using dielectric lens layers only (without using MM). In the second step, the distance of the dielectric lens layer from the antenna was studied. Then the antenna gain was investigated by using dielectric layer in 2 layers. In the next step, a size and distance value was randomly selected for the

dielectric layer. MM lens layer having the same material properties as the dielectric lens layer was then designed. Antenna gain graphs were obtained by adding the obtained metamaterial lens layer in front of CMA in single and double layers as in the previous step. With these processes, it is aimed to determine how much of the gain of the newly proposed metamaterial antenna actually originates from the dielectric layer. In the next stage, firstly the gain graphs of the antenna obtained using metamaterial lens layers were compared with gain graph of CMA. Then, the gain graphs obtained by adding the lens layers made by using dielectric material in front of MYA without using metamaterials and the gain graphs obtained using metamaterials were compared.

## MATERIALS AND METHODS

The first work in this article is to design the CMA. All operations were made based on this CMA antenna comparison and all simulation operations with CST software. CMA has been chosen as the reference antenna because of its consistent electromagnetic propagation and easy to see comparisons. The CMA is designed as shown in Figure 1, with a resonant frequency of 2.45 GHz. For the antenna substrate, FR4 material, which was  $\epsilon_r = 4.3$  and the loss tangent  $\tan \delta = 0.025$ , was used. Antenna parameters are given in Table 1.

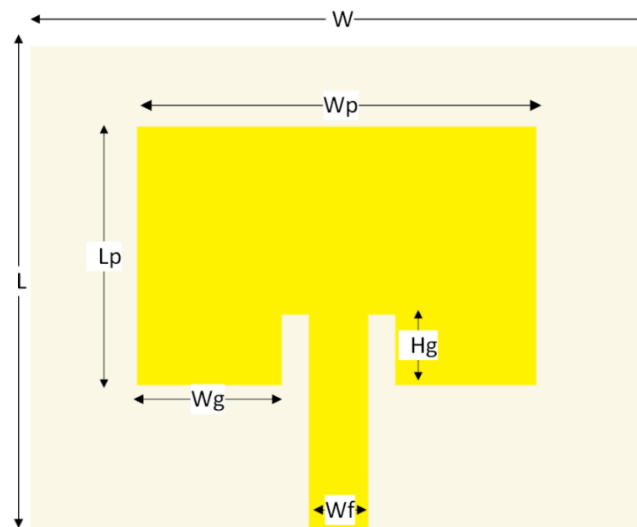

Figure 1. Conventional microstrip antenna (CMA)

Table 1. CMA design parameters

Parameters	Value(mm)
Antenna width (W)	65
Antenna length (L)	50
Patch width (Wp)	35
Patch length (Lp)	29
Substrate thickness (h)	1.55
Patch thickness (Mt)	0.035
Line width (Wf)	7
Hg	8.5
Wg	12.5

All electromagnetic simulation operations of the antenna were carried out in the frequency range of 1.4 GHz to 3.4 GHz with CST program which is an electromagnetic program. According to the results of the simulation process, the S11 graph of the antenna was obtained as shown in Figure 2 and the gain graph as shown in Figure 3. Figure 2 shows that the resonant frequency of the CMA at 2.45 GHz is 18.99 dB and Figure 3 shows that the antenna gain is 3.72 dBi.

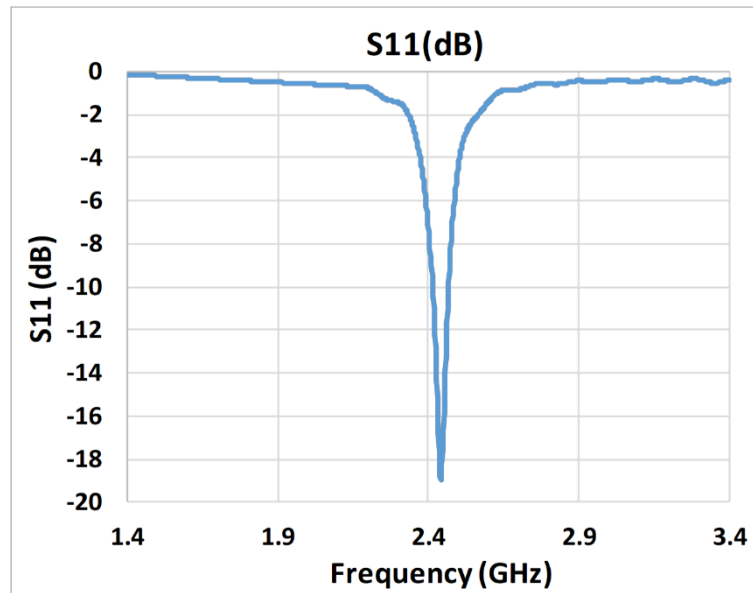

Figure 2. S11 graph of CMA

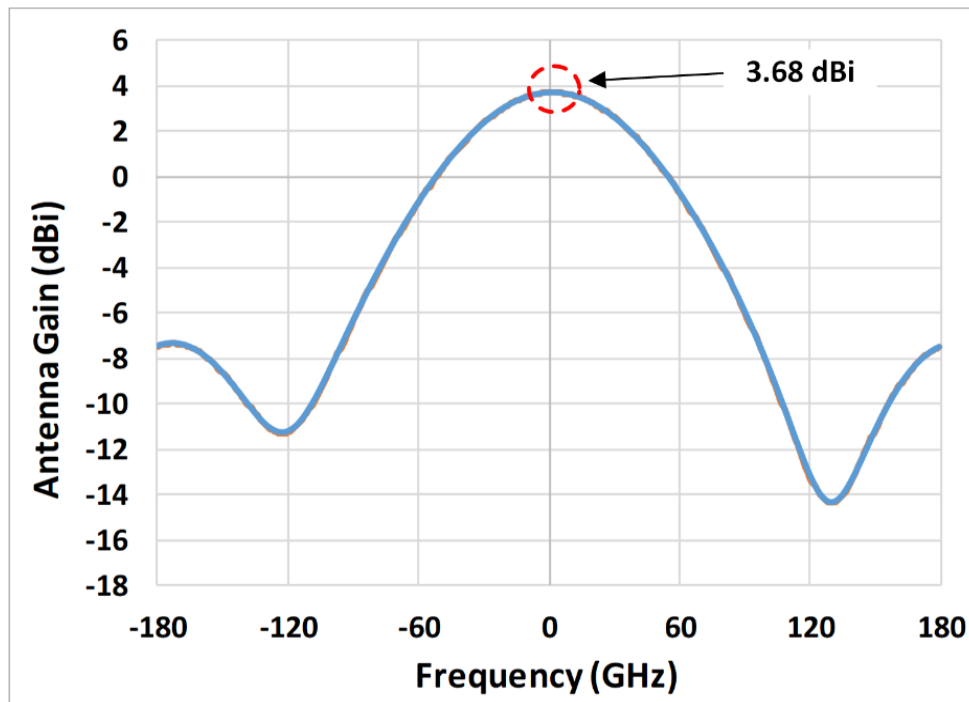

Figure 3. The gain graph of CMA

## RESULTS AND DISCUSSION

### The effect of dielectric lens layer's dimensions and the distance between the antenna and the lens layer on the antenna gain (Without MM layer).

In this section, only dielectric substrate was used as lens layer and the effect of the dielectric lens layer on antenna gain was observed by changing the dimensions. Initially, a layer having a dielectric material substrate (without a copper layer) of FR4 material was designed using the CST software. This lens layer was then placed in front of the previously designed CMA at a distance of  $\lambda / 4$  from the antenna as shown in Figure 4. The dimensions of the dielectric lens layer were selected to be square, multiples of  $\lambda / 16$  for 2.45 GHz and simulated for each lens size.

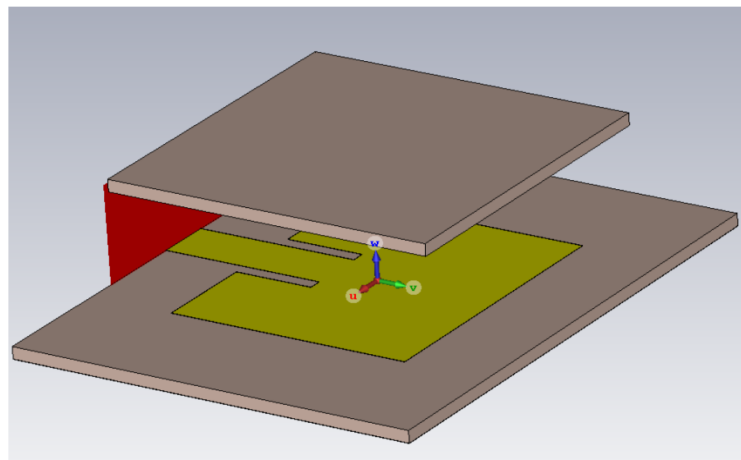

Figure 4. CMA with dielectric lens layer

For the dielectric lens used, FR4 material with  $\epsilon_r = 4.3$  and the loss tangent  $\tan \delta = 0.025$ , which is readily available, was used. The distance of the lens layer from the antenna was chosen to be 25mm. At the end of the simulation process, the gain graph for the lens layer in each dimension of the antenna is obtained as shown in Figure 5 and Table 2.

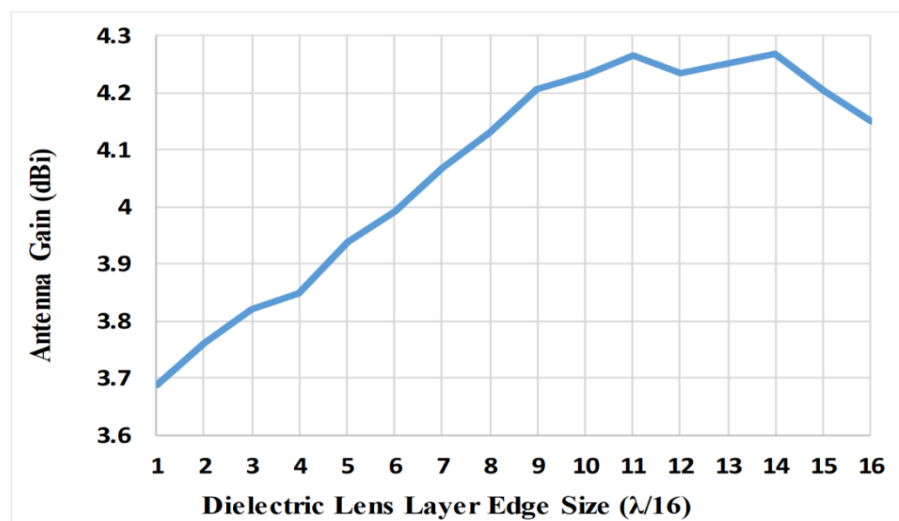

Figure 5. CMA gain variation graph by dielectric lens size

**Table 2.** CMA gain variation data and percentage increase according to dielectric lens size

Dielectric lens size	Gain (dBi)	Gain enhancement (%)
1 x $\lambda/16$	3.6877753	0.32%
2 x $\lambda/16$	3.7624687	2.35%
3 x $\lambda/16$	3.8209785	3.94%
4 x $\lambda/16$	3.8492234	4.71%
5 x $\lambda/16$	3.9375284	7.11%
6 x $\lambda/16$	3.9917832	8.59%
7 x $\lambda/16$	4.0691598	10.70%
8 x $\lambda/16$	4.1312341	12.38%
9 x $\lambda/16$	4.206475	14.43%
10 x $\lambda/16$	4.2321599	15.13%
<b>11 x <math>\lambda/16</math></b>	<b>4.266253</b>	<b>16.06%</b>
12 x $\lambda/16$	4.2347388	15.20%
13 x $\lambda/16$	4.2504347	15.63%
14 x $\lambda/16$	4.2668984	16.07%
15 x $\lambda/16$	4.2029981	14.34%
16 x $\lambda/16$	4.1493409	12.88%

As shown in Figure 6 and Table 2, it is seen that the gain of the obtained antenna varies according to the dielectric lens layer size. The simulation process was performed for 10 values such that the dimensions of the dielectric lens layer were multiples of  $\lambda / 8$ . According to these data, it is seen that by increasing the dielectric lens layer dimensions up to  $14 \lambda / 16$  (maximum 16.07%), antenna gain is increased and after  $14 \lambda / 16$  the amount of increase is decreased. As a result, it is seen that the dimensions of the dielectric lens layer have an effect on the antenna gain and that the lens dimensions should be selected correctly. In addition, the 3-dimensional volume of the antenna increases with increasing lens dimensions. Therefore, it is a disadvantage when the antennas used are desired to be smaller.

In the next stage, the effect of the distance between the antenna and the dielectric lens layer on the antenna gain is examined. For this purpose, firstly, dielectric lens layer made of FR4 ( $\epsilon_r = 4.3$ ,  $\tan \delta = 0.025$ ) and  $5 \lambda / 16$  (38.27 mm) sizes were chosen randomly and designed with CST program. This designed lens layer was then placed in front of the antenna and the simulated operation was performed sequentially by increasing the distance between the antenna and the lens layer from  $\lambda / 16$  to  $\lambda$  for 16 values. As a result of the simulation process, the gain change graph according to the distance between antenna-dielectric lens layer was obtained as shown in Figure 6 and Table 3.

As shown in Figure 6 and Table 3, according to these data, the distance between a lens layer made only with dielectric substrate and CMA antenna does not have a big effect on the antenna gain but it has a maximum effect of 7% for  $\lambda / 4$  distance. It is already known that the values with the lowest reflection will be in the multiples of  $\lambda / 4$ . As a result, considering the figures and tables, the best gain was obtained according to the best antenna size and distance as 4.266.

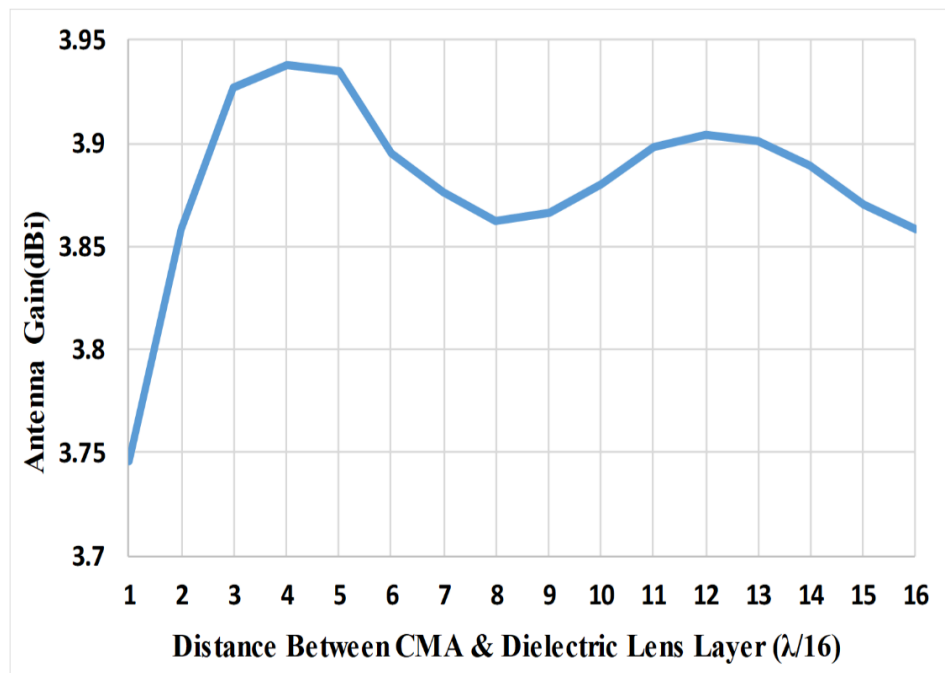

**Figure 6.** Antenna gain change graph according to distance between CMA and Dielectric lens layer

**Table 3.** Antenna gain change data and percentage increase over distance between CMA and dielectric lens layer

Distance between CMA & Dielectric Lens Layers	Gain(dBi)	Gain enhancement (%)
1 x $\lambda/16$	3.746369	1.91%
2 x $\lambda/16$	3.8577954	4.95%
3 x $\lambda/16$	3.9265873	6.82%
<b>4 x <math>\lambda/16</math></b>	<b>3.9375284</b>	<b>7.11%</b>
5 x $\lambda/16$	3.9348072	7.04%
6 x $\lambda/16$	3.8948381	5.95%
7 x $\lambda/16$	3.8760715	5.44%
8 x $\lambda/16$	3.8621266	5.06%
9 x $\lambda/16$	3.866516	5.18%
10 x $\lambda/16$	3.8805397	5.56%
11 x $\lambda/16$	3.8983188	6.05%
12 x $\lambda/16$	3.9036847	6.19%
13 x $\lambda/16$	3.9011069	6.12%
14 x $\lambda/16$	3.8892974	5.80%
15 x $\lambda/16$	3.8699352	5.28%
16 x $\lambda/16$	3.8577819	4.95%

### Effect of MM lens layer on antenna gain

The use of a reference patch antenna and the MM lens layer is frequently used by many researchers and engineers as it increases the gain and directivity of the antenna. Different MM cells are needed for different frequency ranges and applications. It is desirable for an MM cell to have a negative refractive index over a wider frequency range. Because if the MM used has a negative refractive index over a wide frequency range, the number of applications that can use this MM will increase. In this study, square split

ring resonator (SSRR) was used and the effect of MM lens layer on the CMA gain we designed was investigated. For this, a SSRR cell with a negative refractive index up to a frequency of 2.75 GHz was first designed as shown in Figure 7. The dimensions of the MM structure are given in Table 2.

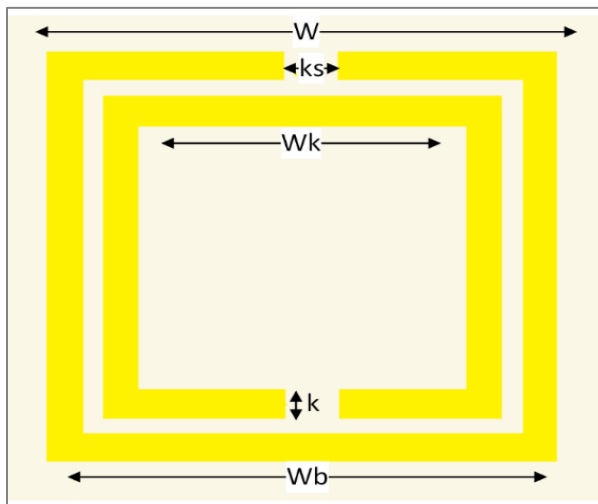

Figure 7-a. Top layer of SSRR

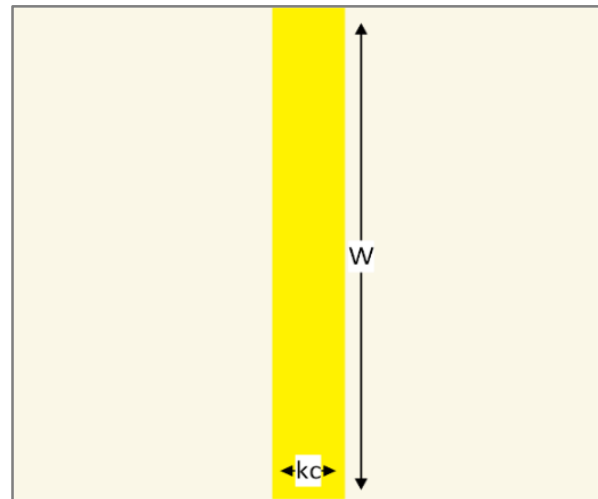

Figure 7-b. Bottom layer of SSRR

Table 4. Dimensions of SSRR cell

Parameters	Value(mm)
Substrate width (W)	7.653
Substrate thickness	1.55
Patch thickness	0.035
Wb	7
Wk	5.15
k	0.4
ks	0.5
kc	1

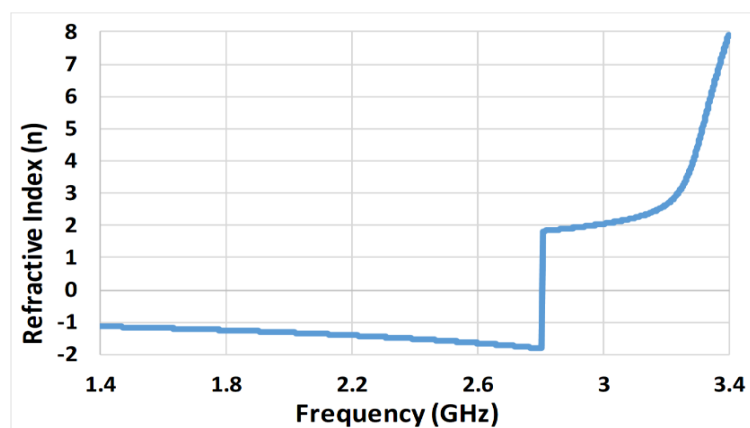
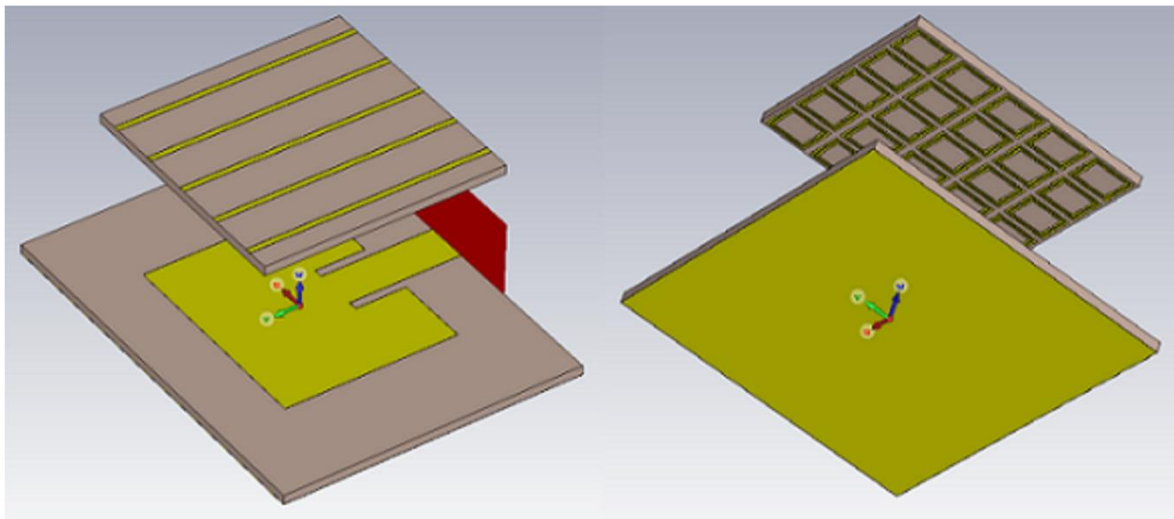

Figure 8. The refractive index of SSRR cell



The dimensions of the designed SSRR cell were chosen such that the refractive index was negative. As a result of the simulation with dual port operation, refractive index for 2.45 GHz was obtained as shown in Figure 8.

The MM lens layer shown in Figure 7 is designed with a CST program using 25 pieces in a 5x5 array. Then, by placing this designed lens layer in front of the CMA antenna, as shown in Figure 9, the proposed antenna structure is obtained. The MM was placed in front of the antenna at a distance of  $\lambda / 4$  from the CMA with a substrate width of  $5\lambda / 16$ . Here, the distance from the antenna is chosen as  $\lambda / 4$ , because it is the best result for the examination with the dielectric lens layer. The reason why the lens layer is selected as  $5\lambda / 16$  is to obtain a smaller size antenna. Because an antenna is more compact, it is preferred in developing technologies. Then, the antenna system with the dielectric substrate of the same dimensions was redesigned as shown in Figure 4 (Without MM patch shape). After this stage, both antenna with the MM lens layer and antenna with dielectric lens layer were separately simulated.



**Figure 9.** Top and bottom view of the recommended antenna

After the simulation process, gain models of both antenna systems were obtained as shown in Figure 10. When Figure 10 is examined, according to the simulation results, the gain of the reference antenna is 3.68 dBi, the gain of antenna obtained by using the reference antenna and the dielectric lens layer together is 3.95 dBi and finally, the gain is 4.5 dBi when the reference antenna is used with the MM lens layer. When these results are analyzed, it is observed that the effect of dielectric lens layer is 7.3% and the effect of MM lens layer is 22.2% in CMA antenna gain increase.

In the next study, it is aimed to see the change of antenna gain when the lens layer is placed in two layers. Therefore, in the first stage, dielectric lens layers of  $5\lambda / 16$  dimensions were placed and simulated in two layers, the first one being  $\lambda / 4$  away from MYA and the second as far as  $\lambda / 2$ , as shown in Figure 11. In the second stage, MM lens layers of the same distance and size were replaced and simulated as shown in Figure 12 instead of dielectric lens layers.

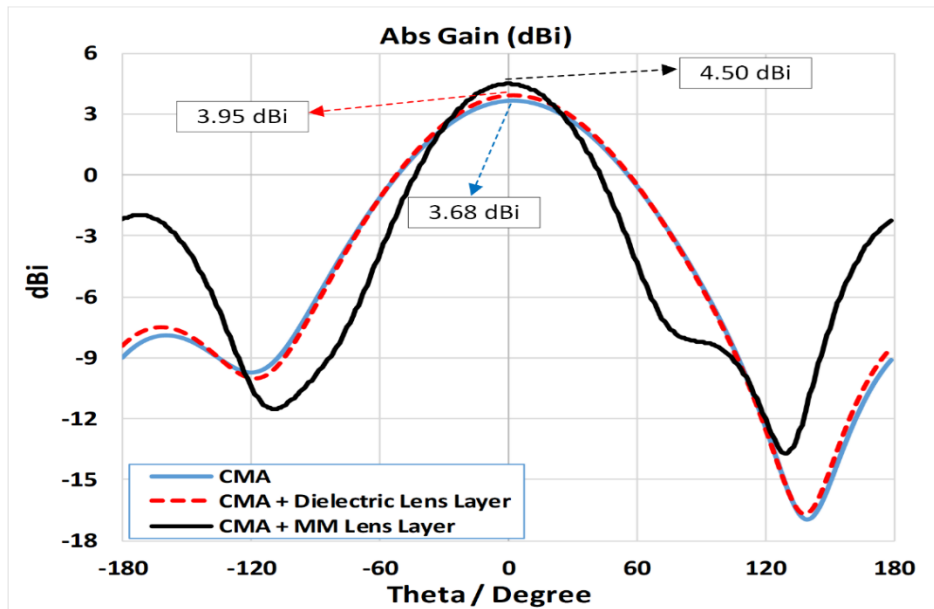

Figure 10. Gain graph of reference and proposed antennas

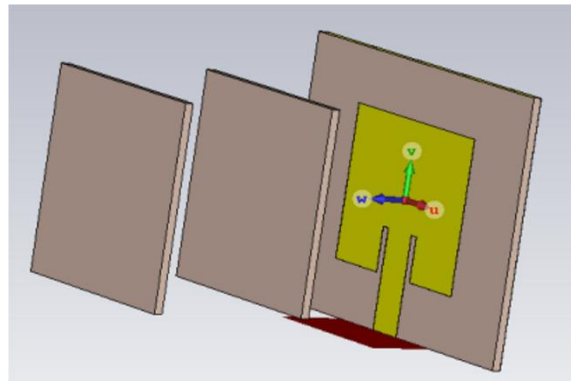

Figure 11. Dielectric double lens layer placed in front of CMA

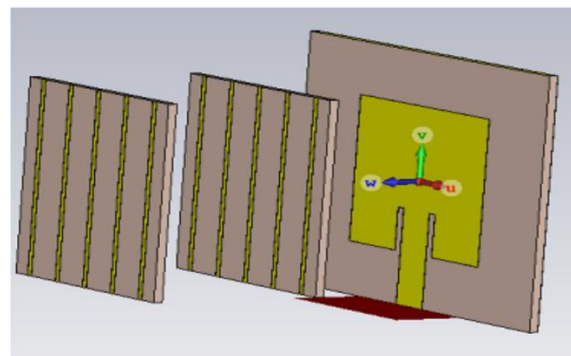
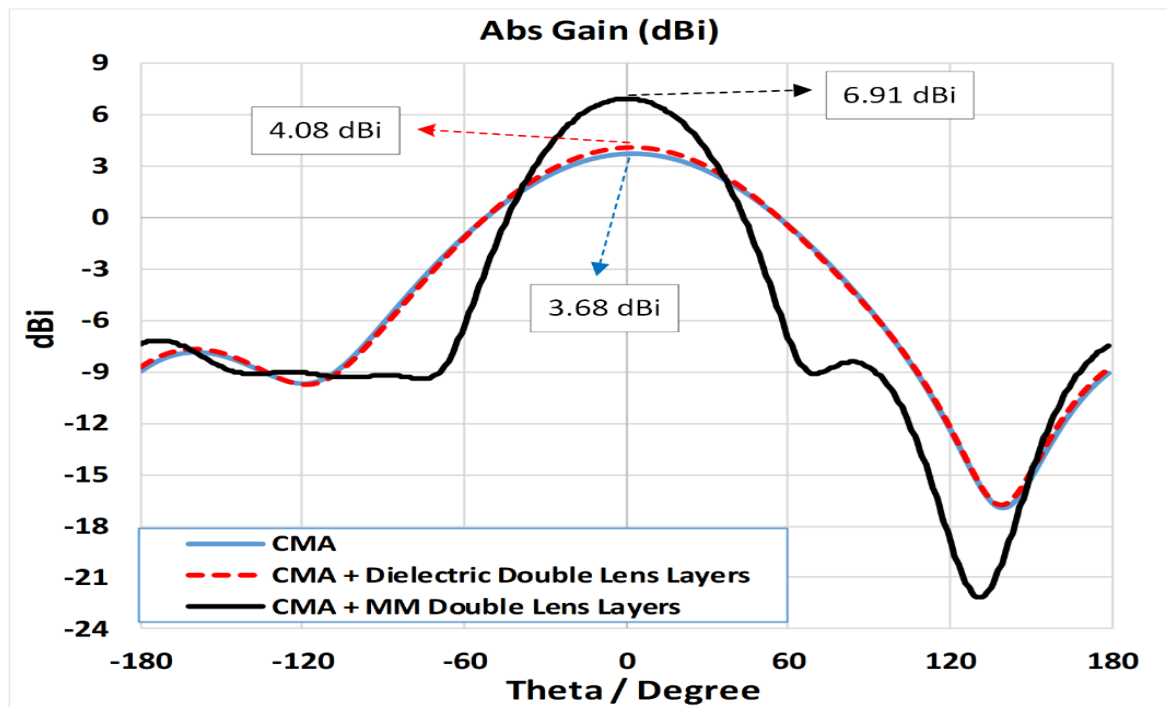

Figure 12. MM double lens layer placed in front of CMA

As a result of the simulation process, the gain diagrams of the dual dielectric lens layer and dual MM lens layer antenna structures are obtained in Figure 13.



**Figure 13.** The gain graph of CMA, CMA with dual dielectric lens layers and with MM lens layers

When Figure 13 is examined, according to the simulation results, the gain of the reference antenna is 3.68 dBi and the antenna gain is 4.08 dBi with the use of the reference antenna and the dielectric double lens layer and the gain of the antenna system obtained by using the reference antenna with the MM lens layer is 6.91 dBi. When these results were analyzed, it was observed that the effect of dielectric lens layer was 10.8% and the effect of MM lens layer was 87.8% in CMA gain increase. All data are collected in Table 5 to see the effect of all antenna configurations on the antenna gain.

**Table 5.** Gain graphs according to antenna configurations

Antenna Configurations	Gain (dBi)	Gain enhancement (%)
CMA	3.68	-
CMA + Dielectric Single Layer Lens	3.95	7.30%
CMA + Dielectric Double Layers Lens	4.08	10.80%
CMA + MM Single Layer Lens	4.5	22.20%
CMA + MM Double Layers Lens	6.91	87.80%

## CONCLUSION

In this study, the effect of dielectric substrate parameters (Sizes-Distance) used on lens layers on the gain of metamaterial antenna was investigated. For this purpose, the classical microstrip patch antenna was designed first. Then, a study was performed on the lens layer dimensions obtained using only dielectric FR4 substrate (without adding MM) and the lens size was increased by  $\lambda / 16$  each time. Accordingly, it was observed that increasing the size of the lens layer increased the antenna gain to a

certain size and a gain increase of up to 16.06% was achieved. However, this is a disadvantage as the size of the lens layer is large, which is not desirable in developing technologies. Then, the distance of the dielectric lens layer from the antenna was changed by  $\lambda / 16$  and the antenna gains were obtained and according to these results, a maximum gain of 7.11% was obtained by selecting the appropriate distance between the antenna-lens layer. In the next step, the MM lens layer and dielectric lens layers were selected at the same size and distance and simulated as single and double layers. According to these results, gain of 22.3% gain was obtained with single layer of MM lens and 7.30% gain increase with only dielectric lens layer. 87.8% gain was achieved with the use of double layer MM lenses, and 22.2% gain increase was achieved with the dielectric lens layer of the same dimensions and distances. As a result, the data obtained showed that increasing the dimensions of the dielectric lens layer had a positive effect on the antenna gain increase up to a certain size. It is also possible to increase the antenna gain by using MM in two layers.

## REFERENCES

- Arayeshnia A, Bayat A, Keshtkar-Bagheri M, Jarch S, 2019. Miniaturized low-profile antenna based on uniplanar quasi-composite right/left-handed metamaterial. *Int J RF Microw Comput Aided Eng.*, 2019, 29:e21888.
- Dadgarpour A, Zarghooni B, Virdee BS, Denidni TA, 2014. Beam tilting antenna using integrated metamaterial loading. *IEEE Transactions on Antennas and Propagation*, 2014, 62(5):2874-9.
- Esmail BA, Majid HB, Dahlan SH, Abidin ZZ, Rahim MK, Jusoh M, 2019, Planar antenna beam deflection using low-loss metamaterial for future 5G applications. *International Journal of RF and Microwave Computer-Aided Engineering*, 2019, e21867.
- Rahman MN, Islam MT, Isla, S, Samsuzzaman S, 2018. Resonator based metamaterial sensor to detect unknown materials. *Microw Opt Technol Lett.*, 2018, 60: 1681– 1685. <https://doi.org/10.1002/mop.31218>
- Singh HS, Kalraiya S, Meshram MK, Shubair RM, 2019. Metamaterial inspired CPW-fed compact antenna for ultrawide band applications. *Int J RF Microw Comput Aided Eng.*, 2019; 29:e21768. <https://doi.org/10.1002/mmce.21768>
- Singh M, Kumar N, Dwari S, Kala P, 2019. Metamaterial-inspired miniaturized antenna loaded with IDC and meander line inductor using partial ground plane. *Int J RF Microw Comput Aided Eng.*, 2019, 29:e21863. <https://doi.org/10.1002/mmce.21863>.
- Kumar A, Kumar VD, 2013. High-performance metamaterial patch antenna. *Microw. Opt. Technol. Lett.*, 2013, 55: 409-413. [doi:10.1002/mop.27304](https://doi.org/10.1002/mop.27304)
- Lei Jie, 2018. Design of 2.4G Wi-Fi antenna (Design of 2.4G Metamaterial and Stacked Microstrip Wi-Fi Antennas), Northumbria University Publications, 2018, 10.13140/RG.2.2.12057.52329.
- Tütüncü B, 2019a. Compact low radar cross-section microstrip patch antenna using particle swarm optimization. *Microw. Opt. Technol. Lett.* 2019, 61: 2288– 2294.
- Tütüncü B, 2019b. Polarizasyon Mod Bağımsız Üçlü Bant Mikrodalga Sinyal Emici. *Journal of the Institute of Science and Technology*, 2019, 9.1: 295-301.
- Veselago VG, 1968. The electrodynamics of substances with simultaneously negative values of  $\epsilon$  and  $\mu$ . *Sov. Phys. Uspekhi*, 1968, 10: 509-514.