

ELECTRICAL PROPERTIES OF THE NEURON AND ELECTRICAL MODELLING OF PASSIVE NEURON CELL MEMBRAN

M.F. Beyazyuz

Abstract— Neurons are linked to each other and other cells through an electrochemical mechanism. Understanding the electrical properties of neurons is essential for understanding the functioning of the brain. We can model the single neuron by standard electric circuits, and these models could be used for modeling of neuron networks. And modeling of neural networks is important for understanding the whole brain. Although we can model a single neuron by electric circuits, there is a difference between them in terms of the nature of electric charge carriers. While the main charge carrier is electrons in standard electrical circuits, neurons have a different mechanism. The main charge carriers in neurons is ions. The cell membrane is an insulator and there are some specific channels on it with different permeability for different ions. This structure of the cell membrane is very important for signal transmission in neurons. Passive modeling of the cell membrane is the basis of signal transduction in neurons.

Keywords—Neuron, Passive Cell Membrane, Electrical Modeling, Electrical Properties.

1. INTRODUCTION

NEURONS interact with each other and other cells in the body with electrochemical pulses. They form neural networks that create the control and decision mechanism of the organism. Each neuron can create thousands of connections with other neurons. At a typical brain, there are about 100 trillion synapses. Also, a typical neuron fires 5 - 50 times per second [1]. It is very difficult to understand the functioning of such a complex structure. To model this large and complex structure, passive neurons must first be understood. In this article, the electrical membrane model will be examined in case the membrane potential is below the threshold value. This model provides a basis for modeling the action potential that plays an important role in cell communication and then modeling neuronal networks that interact with each other. For this, the physical properties of neurons will be examined first. Then the structures that enable signal transmission in neurons and their electrical properties will be examined.

2. LITERATURE REVIEW

To model neural networks, the physiology of a single neuron must be well understood. In this way, neuron networks will be better understood. Many models examine the electrical structure of neurons passively or actively. One of the most famous models that model the functioning of the neuron is The Hodgkin – Huxley model.

This model examines the structure of the passive membrane and the propagation mechanism of the action potential. *Morris-Lecar Model* is another successful model that can model the active properties of the neuron. The feature of these two models is that they are models containing single neurons. In this study, the physiology of the neuron will be examined and a simple electrical modeling of the membrane will be made for the passive neuron [1-4].

3. PHYSIOLOGY OF NEURONS

A typical human neuron can be examined in three main sections as dendrite, axon, and soma. The cell body of the neuron, the soma, is about 20 μm in diameter and contains most of the organelles such as the nucleus, mitochondria, endoplasmic reticulum, ribosomes, and other organelles. At the cell body, the cell produces ATP, packs the neurotransmitters, contains genetic material and combines cell proteins [3]. Dendrites take impulses which are excitatory or inhibitory from other cells and transfer them to the cell body. Axon is a long nerve fiber that transmits a signal from the cell body to another nerve cell or muscle cell. Axons have various lengths and diameters. Mammal axons are usually around 1 to 20 μm in diameter, and some of them can reach 1 m in length. Some axons can be covered with an insulating layer called the myelin sheath. The myelin sheath is not continuous but is divided into sections separated by Ranvier nodes at regular intervals [1,3,4].

The place where the dendrite of one neuron interacts with the axon of another neuron is called the synapse. Each neuron has an average of 1,000 synapses, but this number can vary greatly [2]. The information goes unidirectionally from the axon side called as pre-synaptic terminal to the dendrite side called the post-synaptic terminal. There is a gap called the synaptic cleft between the terminals which is approximately 10 - 50 nm [3]. Neurotransmitters are specialized molecules packed in vesicles in soma, carried by the legs kinesin to the end of the presynaptic axon and released into the synaptic cleft to reach the post-synapse and excite or inhibit an electrical impulse to the receiver neuron, that process is the reason of unidirectionally signal flow through the pre-synapse terminal to the post-synapse terminal [3].

The cell membrane is about 7.5 to 10.0 nm in diameter and covers the entire cell. The main content of the cell membrane is phosphoglycerates, consisting of glycerides and phosphoric acid. This molecule consists of two main parts, the head of the molecule consists of phosphoric acid, which is hydrophilic, the molecule's tail consists of hydrophobic hydrocarbon chains. These molecules are arranged so that their hydrophilic portions face out [3].

Muhammed Furkan Beyazyüz is with Electrical Engineering Faculty Istanbul Technical University, Istanbul, Turkey, (e-mail: beyazyuz@itu.edu.tr) 

Manuscript received Sept 12, 2019; accepted Nov 20, 2019.

4. IONS AS CHARGE CARRIERS

Although the electrical properties in the neuron are very similar to the standard electrical circuit properties, there is a difference between them. The current flowing through the axon is carried out by ions, not electrons, and voltages are potential differences created by gradients in ionic concentrations.

There are two kinds of forces that affect the ions, one is the electrostatic force and the other is the diffusion force. Diffusion force is related to membrane permeability, the electrostatic force is related to interactions of charged particles. There is a kind of balance between the intracellular and extracellular ions in the passive neuron. This balance can be examined by the Nernst equation, which is using for single ions [1,2,5]. The Nernst equation is shown Eq.1. [2, 4].

$$V_{in} - V_{out} = \frac{RT}{zF} \ln \frac{[X]_{in}}{[X]_{out}} \quad (1)$$

V_{in} = Intracellular voltage

V_{out} = Extracellular voltage

R = The ideal gas constant

T = The temperature in Kelvin

z = The valence of the ion

F = Faraday's constant

$[X]_{in}$ = Intracellular concentration of the ion

$[X]_{out}$ = Extracellular concentration of the ion

Goldman-Hodgkin-Katz equation is an expanded version of Nernst equation; this equation only gives the relationship between multiple ions. The Goldman-Hodgkin-Katz equation is shown below; [2, 4].

$$V_{in} - V_{out} = \frac{RT}{F} \ln \frac{P_K[K^+]_{in} + P_{Na}[Na^+]_{in} + P_{Cl}[Cl^-]_{in}}{P_K[K^+]_{out} + P_{Na}[Na^+]_{out} + P_{Cl}[Cl^-]_{out}} \quad (2)$$

V_{in} = Intracellular voltage

V_{out} = Extracellular voltage

R = The ideal gas constant

T = The temperature in Kelvin

F = Faraday's constant

P_X = Permeability of each of the three ionic species

$[X]_{in}$ = Intracellular concentration of each ion

$[X]_{out}$ = Extracellular concentration of each ion

Intracellular fluid consists of an aqueous solution containing more dense potassium than extracellular fluid, but less dense chloride, sodium, calcium, and magnesium, also in the intercellular fluid, there are some organic anions which cannot leave the cell. Ions are the main factor that determines the electrical properties of neurons. There are some disadvantages to carrying electricity with ions, but they are vital for many activities of the brain. Ions transmit signals much slower compared to electrons because it is very difficult to move ions. However, the diversity in ions provides important capabilities for signal transmission [5,6].

5. ELECTRICAL PROPERTIES OF NEURONS

The cell membrane is the main structure responsible for receiving information from the cell's environment as an interface between inside the cell and outside the cell. The movement of ions in and out of the cell forms the basis of the electrical transmission of a signal [7].

There is a current that flows across the membrane called transmembrane current. Transmembrane current is the sum of the capacitive current, the ionic current, the synaptic current, and the stimulus current. The capacitive current is a result of the natural capacitance of the cell membrane. The ionic flux, the primary membrane current, can be the sum of currents of different ion types. When a synapse is activated by neurotransmitter released from presynaptic terminals, synaptic currents are generated. And the stimulus current is an external current applied to the membrane. The transmembrane current equation 3 is shown below [3,8].

$$I_m = I_{cm} + I_{ion} + I_{syn} - I_{stim} \quad (3)$$

I_m = The transmembrane current

I_{cm} = The capacitive current

I_{ion} = The ionic current

I_{syn} = The synaptic current

I_{stim} = The stimulus current

The cell membrane consists of a double-layer lipid layer and, at rest, there is a potential difference between the two sides of the membrane, as a result of which the cell membrane has a capacity value. Membrane capacitance can be calculated with the following equation 4 [2].

$$C_m = \frac{k\epsilon_0}{d} \quad (4)$$

C_m = The membrane capacitance

k = The dielectric constant of the insulator

ϵ_0 = The permeability of free space

d = The membrane thickness

Structures that are hollow proteins with pores in their middle and that allow ions to flow into or out of the cell are called ion channels. Channel proteins work like holes in the cell membrane. Most of the electrical properties of cells and tissues are formed by the movement of ions through these channels. Because of that, there is a voltage difference between intracellular and extracellular, called transmembrane potential. When cells not in transmission, transmembrane potential is about -60 mV, that value known as resting membrane voltage [3,4,9].

$$V_m = V_{in} - V_{out} \quad (5)$$

V_m = Transmembrane potential

V_{in} = Intracellular voltage

V_{out} = Extracellular voltage

Any positive change in membrane potential is called depolarization, negative change is called repolarization. If the membrane tension is below the resting membrane tension, it is called hyperpolarized. If the intracellular potential difference rises above a certain value which is called the threshold as a result of excitations from dendrites, this triggers the action potential flowing through axons [3,9].

6. THE ACTION POTENTIAL

The nerve axon acts as a very weak electrical conductor because the axoplasm, the cell fluid inside the axon, has a very high resistance. If we compare the resistances of a squid axon with copper wire of the same diameter, the resistance for the squid axon is 30 to 60 ohms-cm, while the copper wire is 1.8×10^{-6} ohms-cm, which means 107 times more voltage drop in the axon than copper wire [2].

The signals are carried over axons and transported from the synapse of the sending cell to the dendrites of other cells. The electrical resistance of axons is extremely high. Therefore, the signal is transmitted by a different mechanism. Action potential plays an important role in this transmission mechanism. It has a characteristic structure based on an all-or-nothing basis [10].

The action potential occurs in five stages as rising phase, peak phase, falling phase, sub-phase and refractory period. With the stimuli collected from the dendrites, some stimulating or inhibiting changes occur in the intracellular voltage value. These stimuli can come from receptor cells or other neurons. If the threshold value is exceeded as a result of these voltage-gated changes, the permeability of the voltage-gated Na^+ ion channels increases. The membrane potential becomes more positive as a result of the Na^+ ions entering, which also increases the permeability of the voltage-gated Na^+ channels so more Na^+ ions entering into the cell. However, this increase in membrane potential is short-lived, because, after a while, the voltage-gated Na^+ channels close and depolarization stops, this is called the peak phase. Following this, voltage-gated K^+ ion channels are opened and K^+ ions come out of the cell; thus, the membrane potential becomes more negative. After a while, the membrane potential temporary becomes under the resting membrane potential because the permeability of the voltage-transition K^+ ion channels is high. After a while, the permeability of the voltage-gated K^+ ion channels become a normal value, so the action potential ends [5,9,11].

The capacitance value of the cell membrane affects the time required to reach the threshold value because the amount of charge required to reach a certain potential is related to the capacitance. If the capacitance is high, the transmission speed decreases, if it is low, the speed increases. Resistance also affects the time it takes to reach the threshold value, so the speed also depends on the resistance of the environment inside and outside the membrane. In small resistances, the time required to reach the threshold value decreases [4,12].

Myelinated axons produce nerve impulses that spread from one node to another in Ranvier nodes, this type of propagation is called saltatory transmission. Membrane capacitance per length of myelinated axon is higher than the unmyelinated axon, which increases the transmission rate. The resistance of the axoplasm depends on the axon diameter since there is no change

in the axon diameter, the transmission rate increases in the myelinated axons [4,11].

7. EQUIVALENT CIRCUIT OF PASSIVE CELL MEMBRANE

The electrical behavior of the cell membrane can be modeled in terms of electrical circuits. The electrical circuit that models the cell membrane is called the equivalent circuit model. The circuit consists of three components, resistors, batteries, and capacitors. Resistors represent ion channels, batteries represent concentration gradients of ions, capacities represent the charge storage ability of the membrane. Stimulations that exceed the threshold create changes in the permeability of the ion channels. Since the permeability of the ion channels that could be modeled with a linear electrical resistance in the active membrane will change over time, they cannot be modeled with linear resistance elements. Modeling can be done using linear resistors for a passive cell membrane [5,10,12,13]. The modeling of passive neuron membrane is shown below. There is a voltage difference of approximately -60 V between the inside and the outside.

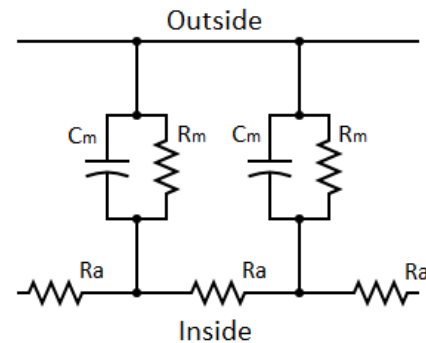

Fig.1. Electrical Modeling of Passive Membrane

R_m = Membrane resistance
 R_a = Axial resistance
 C_m = Membrane capacitance

Also, different ion channels could be determined in terms of different resistance elements. In this situation, the electrical analogy of passive cell membrane gets better. This model is shown below [2, 4].

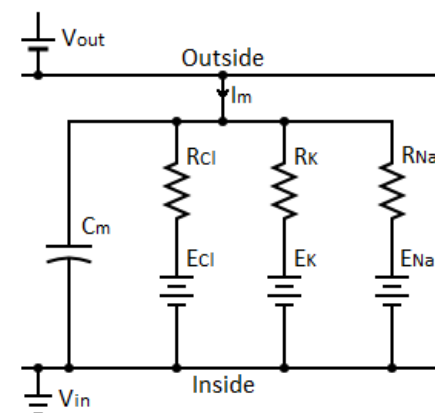

Fig.2. Electrical Modeling of Passive Membrane with Different Ion Channels

The following equations could be found by using electrical modeling of the passive membrane with different ion channels circuit. The capacitance current equal to the sum of the ionic currents and the current source [2,4].

$$V_m = V_{in} - V_{out}$$

$$C_m \frac{dV_m}{dt} = - \frac{V_m - E_{Cl}}{R_{Cl}} - \frac{V_m - E_K}{R_K} - \frac{V_m - E_{Na}}{R_{Na}} \quad (6)$$

I_m = Total transmembrane current

V_{out} = Intracellular voltage

V_{in} = Extracellular voltage

R_{Cl} = Reactance of single Cl^- ion channel

R_K = Reactance of single K^+ ion channel

R_{Na} = Reactance of single Na^+ ion channel

E_{Cl} = Cl^- Nernst potential

E_K = K^+ Nernst potential

E_{Na} = Na^+ Nernst potential

C_m = Membrane capacitance

8. CONCLUSION

As a result, it is important to know the electrochemical properties of neurons to understand neuron networks and the whole brain because neurons interact with each other and other cells with electrochemical mechanisms. An electrical model can be used to simplify signal transmission between neurons, a complex process involving ions and organic machines. An electrical model can be used to simplify signal transmission between neurons, a complex process involving ions and organic machines. In this way, neuron networks can be modeled and the functioning of the brain can be understood more easily. The examination of the electrical model of the passive state neuron is required for modeling the active neuron. The passive neuron cell can be modeled with linear circuit elements.

REFERENCES

- [1] J. Zhang, "Basic Neural Units of the Brain: Neurons, Synapses and Action Potential," pp. 1–38, 2019.
- [2] B. Ermentrout and D. Terman, "Foundations of Mathematical Neuroscience," p. 440, 2008, doi: 10.1007/978-0-387-87708-2.
- [3] J. V. Tranquillo, *Quantitative neurophysiology*, vol.21. 2008.
- [4] J. Malmivuo and R. Plonsey, "Bioelectromagnetism Principles and Applications of Bioelectric," *Oxford Univ. Press*, p. 512, 1995. J. Malmivuo,
- [5] P. E. Greenwood, L. M. Ward, *Stochastic Neuron Models*. 2016.
- [6] S. Alexander, A. Mathie, J. Peters, *ION CHANNELS: Ion Channels*, Vol.164, no. supplement s1. 2011.
- [7] R. A. Gatenby, "The role of cell membrane information reception, processing, and communication in the structure and function of multicellular tissue," *Int. J. Mol. Sci.*, vol. 20, no. 15, 2019, doi: 10.3390/ijms20153609.
- [8] A. Destexhe, Z. F. Mainen, and T. J. Sejnowski, "Synaptic Currents, Neuromodulation and Kinetic Models," *Handb. Brain Theory Neural Networks*, pp. 1–14, 1995.
- [9] B. Eisenberg, "Ionic channels in biological membranes - Electrostatic analysis of a natural nanotube," *Contemp. Phys.*, vol. 39, no. 6, pp. 447–466, 1998, doi: 10.1080/001075198181775.
- [10] R. Brette, "Theory of action potentials," *Theory of Action Potentials*, vol. 6, pp. 1–48, 2018.
- [11] M. Fluidity, N. Impulses, and T. A. Receptor, "The Structure and Function of the Plasma Membrane 4.1," pp. 120–171, 2007.

- [12] Bard Ermentrout, G., *Mathematical Foundations of Neuroscience*. 1990.
- [13] I. N. Sabir, J. A. Usher-Smith, "Electrical Properties of Cells," *A Think. Approach to Physiol.*, pp.1–36, 2008, doi: 10.1142/9789812832887_0001.
- [14] approach," presented at the Evolutionary Computation (CEC), 2010 IEEE Congress on, Barcelona 2010.

BIOGRAPHIES

Muhammed Furkan Beyazyüz is student of Electrical Engineering at Istanbul Technical University, Turkey.