

## Great Solutions for an Angle Question in the Triangle

Seyfullah Hızarcı

Atatürk University Faculty of Education, Erzurum, TURKEY

[seyfullahhizarci@atauni.edu.tr](mailto:seyfullahhizarci@atauni.edu.tr)

### ABSTRACT

In this study, we have shown that there are different solutions of an angle question in the triangle of secondary education.

Key words: Golden Ratio, Angle Question, Triangle and Euclid Geometry

### 1.INTRODUCTION

A major contributor to the field of geometry is [Euclid](#) (365-300 B.C.) who is famous for his works called "The Elements." Today we continue to use the rules for geometry. While continuing primary and secondary education, Euclidean geometry and plane geometry are studied.

When the literature is examined, there are multiple definitions for geometry. According to Coxeter, geometry is perhaps the most fundamental of the sciences that allow man to make predictions (based on observations) about the physical world through purely intellectual processes. The power of geometry is impressive in terms of the accuracy and utility of these inferences and has been a strong motivation to study logic geometry.

Perhaps it may be asserted, that there are no difficulties in geometry which are likely to place a serious obstacle in the way of an intelligent beginner, except the temporary embarrassment which always attends the commencement of a new study.

For a time, it had nowhere (in universities) because geometry was obedient to nothing but rigid facts. Hoobes uses the following expression for geometry; if any person who has the creativity of his nature had attained any degree of perfection there, he would generally think art as evil.

As abstract thinking progresses, geometry becomes much more about analysis and reasoning. Throughout high school there is a focus on analyzing properties of two- and three-dimensional shapes, reasoning about geometric relationships, and using the coordinate system. Studying geometry provides many foundational skills and helps to build the thinking skills of logic, deductive reasoning, analytical reasoning, and problem-solving.

In the following triangle we solved the angle problem in 36 different ways. We are pleased to offer these solutions to geometry lovers.

## 2. Questions and solutions

### 2.1. Questions:

$|AB| = |BD| = |DC|$  and  $m\angle ABD = m\angle DBC = 20^\circ$  if  $m\angle DCA = ?$  what is its degree?  
**(Figure.2.1)**

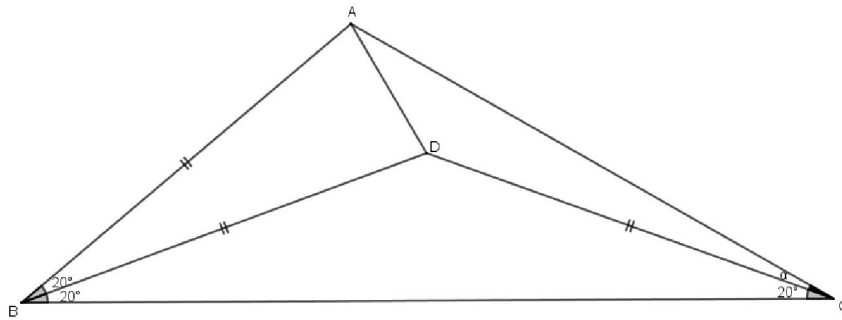

**Figure.2.1**

#### 2.1.1. The first solution:

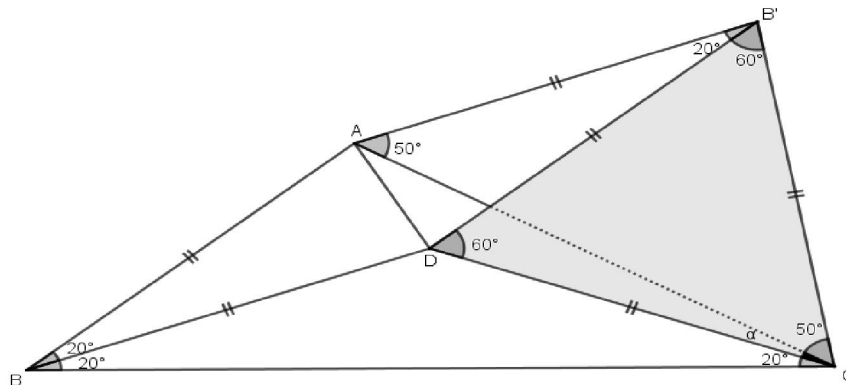
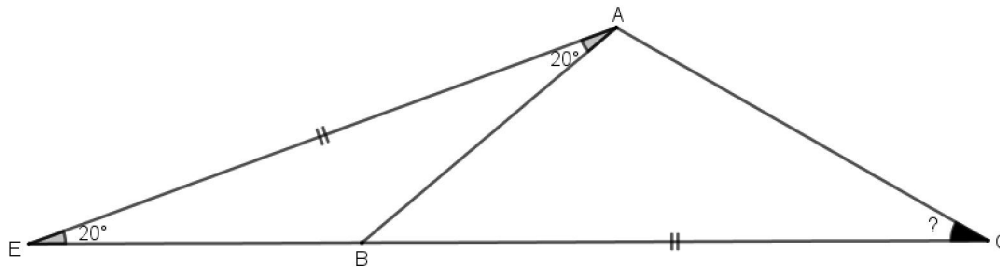

**Figure.2.2**

- Let us draw the symmetry of the ABD triangle against  $[AD]$  edge.
- The symmetry of point B is  $B'$ .
- $B'DC$  is the equilateral triangle and  $B'AC$  is the twin edge triangle.
- That will be  $m\angle DCA = 10^\circ$ .

For the second solution, we have use the following help.

**Lemma.2.1.1** Helpful questions and answers.

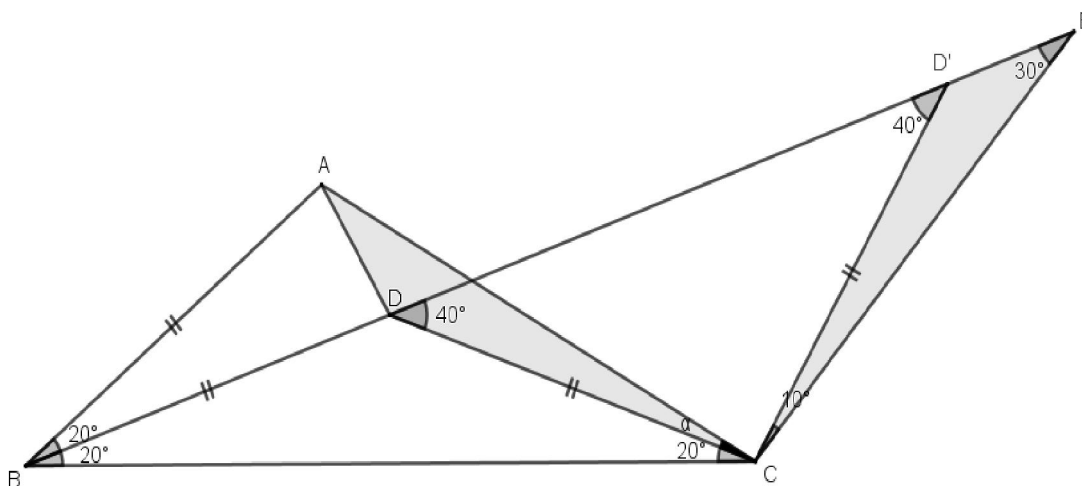

**Figure.2.3**

? = 30. We will use this in the second solution.

**2.1.2. The second solution:**

- On Figure 2.1, extend the correct segment  $[BD]$  and draw the  $DCD'$  twin edge triangle with  $|CD| = |CD'|$ .
- $D'EC = 30$  so that the E point on the  $\overline{BD}$ .
- $mECD' = 10$  is composed of  $ADC = ED'C$  coincident triangles.
- Lemma.2.1.1 gives us  $|CB| = |DE|$ .
- Equality. edge, angle, edge accompanied by axiom  $ABC = CDE$  and  $|CA| = |CE|$ .
- If so, the  $ADC = ED'C$  is  $mADC = 10, \alpha = 10$ . (Figure.2.4)



**Figure.2.4**

**2.1.3. The third solution:**

- Let us take point E so that  $|AB| = |BE|$ .
- On the CB vector and draw the ABE triangle. (Figure.2.5 ).
- Lemma 2.1.1 gives us  $m\angle ACB = 30$ , where  $m\angle ACD = 10$

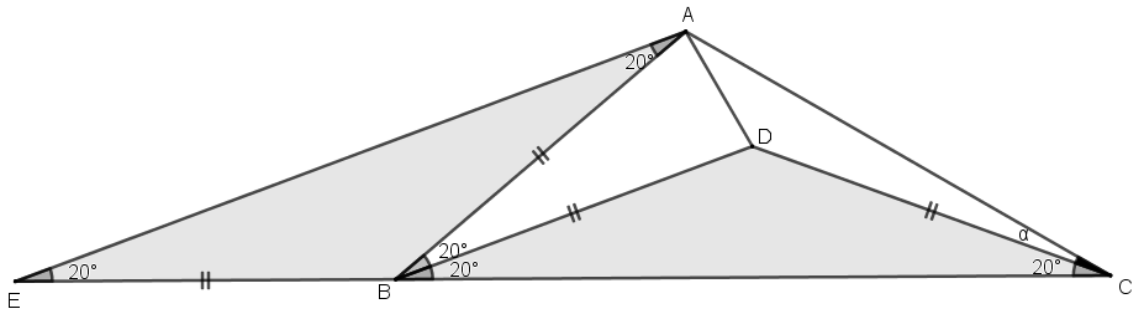

**Figure.2.5**

**2.1.4. The fourth solution:**

- Let's create the ABD equilateral triangle.
- Let's draw the right part of  $[CD]$  .
- ADC triangle is isosceles triangle and ADC angle is 80. From here it is seen that ACD angle is 10 degrees. (Figure.2.6)

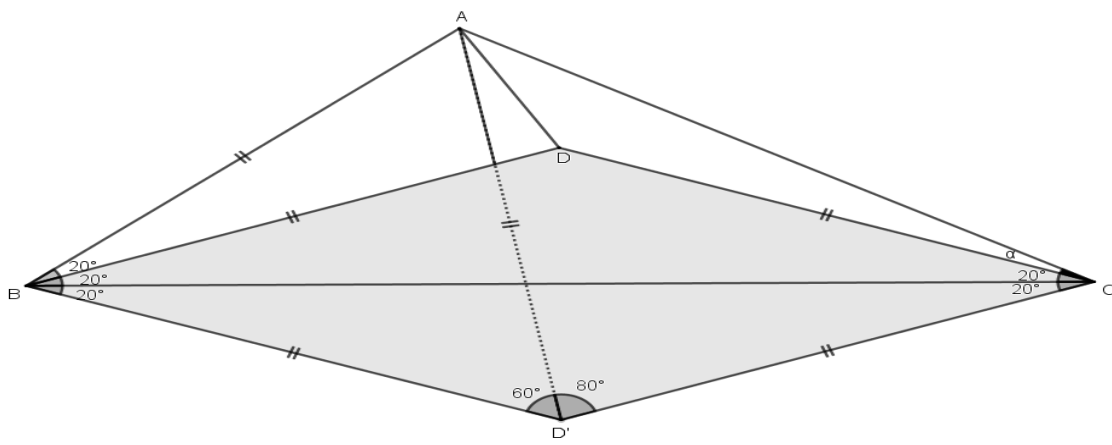

**Figure.2.6**

**2.1.5. The fifth solution:**

- Let's draw the  $C'BA$  equilateral triangle.
- Then combine the points  $C$  and  $C'$ . (Figure.2.7)
- $CBA$  and  $C'DC$  triangles become twin edge triangles.
- The base angles of both are 10.
- In this case the  $AC'$  and  $CC'$  overlap and  $m\angle ACD = 10$ .

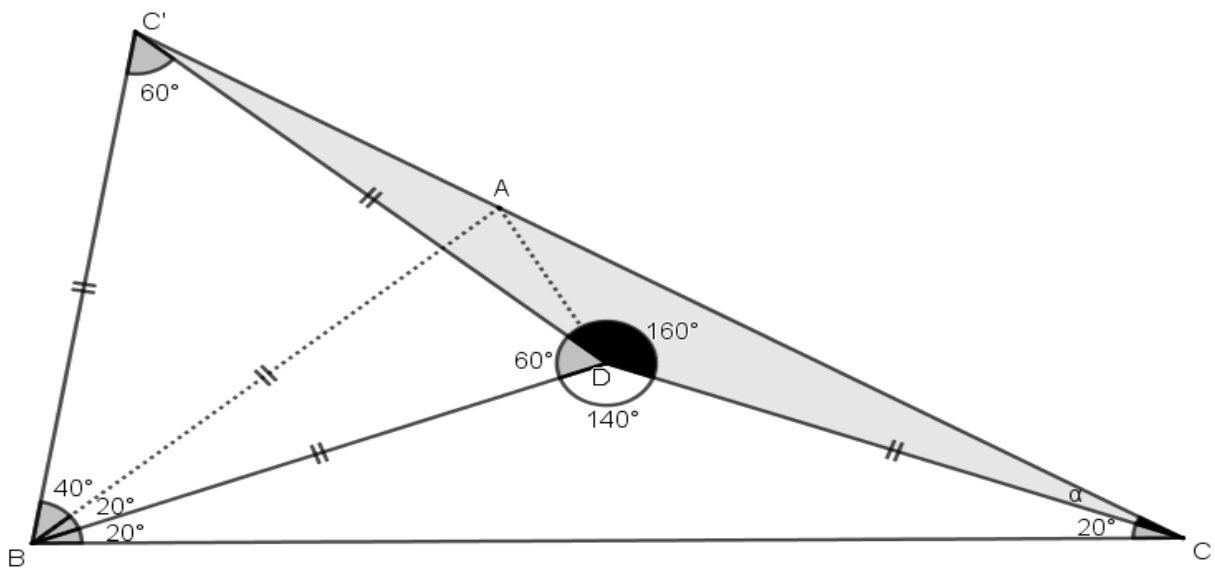

**Figure.2.7**

**2.1.6. The sixth solution:**

- Let's draw  $ABD = D'CD$  (Figure.2.8).
- $m\angle ADD' = 60$  ve  $ADD'$  equilateral triangle becomes
- $ADCD'$  is deltoid,  $[AC]$  becomes angle bisector. Then  $m\angle ACD = 10$

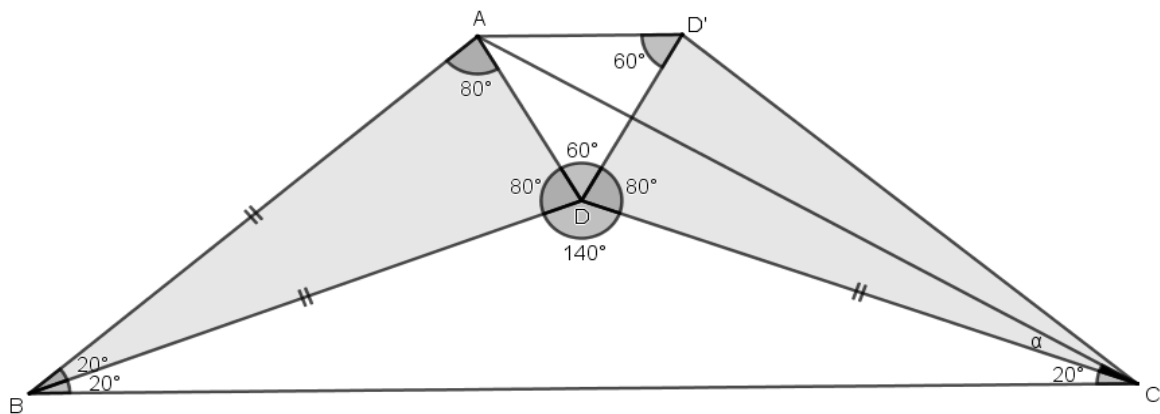

**Figure.2.8**

**2.1.7. The seventh solution:**

- $|BD| = |DC'|$  and  $C'DD'$  let's draw equilateral triangle. (Figure 2.9)
- The triangle  $DD'C$  is drawn.
- $\triangle ABD = \triangle DD'C$  (Edge-angle-edge accompaniment axiom)
- Then  $m\angle ACD = 10^\circ$

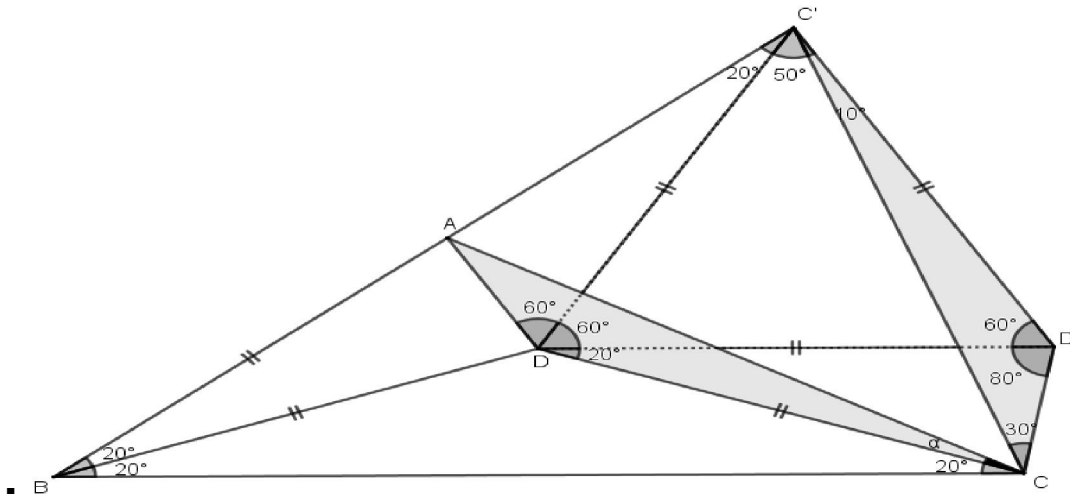

**Figure.2.9**

**3. Conclusion**

**3.1** This question is solved in about 36 ways. Other solutions are given below. I hope the readers will discover these solutions with pleasure. **Contact me when they are geared up.**

**3.2 Other solutions**

**3.2.1 Solutions:**

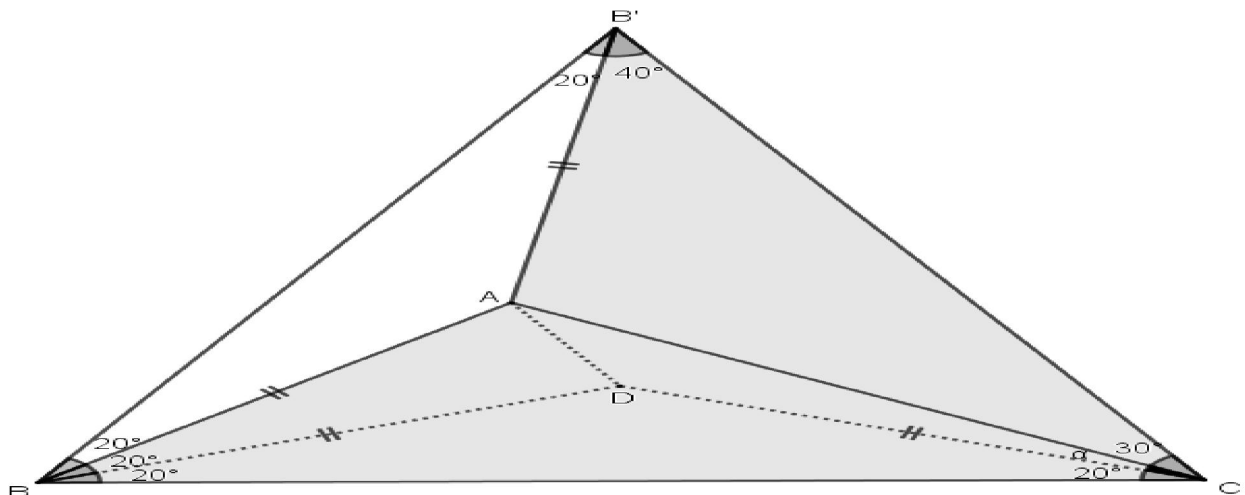

**3.2.2 Solutions:**

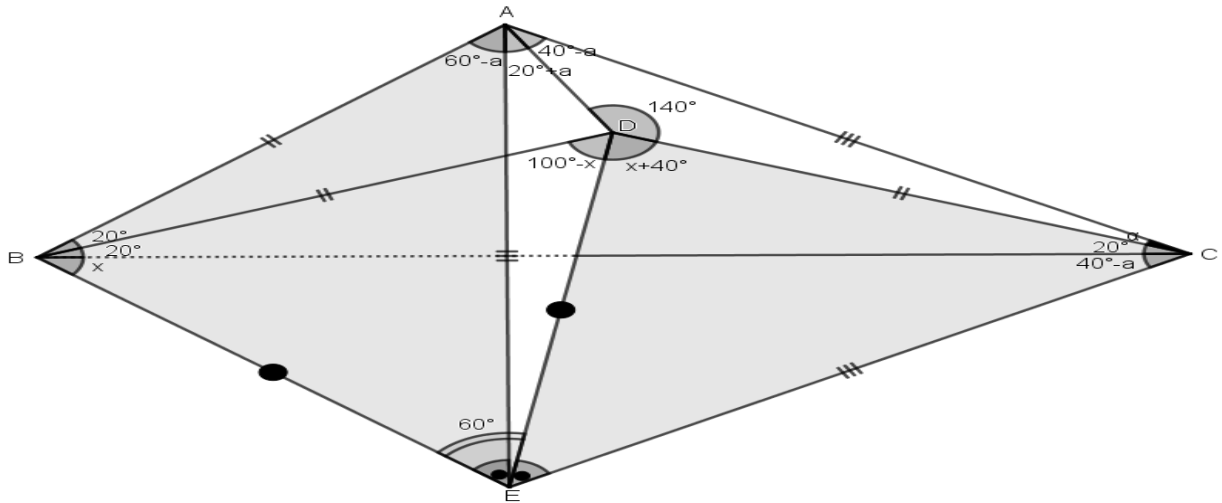

**3.2.3 Solutions:**

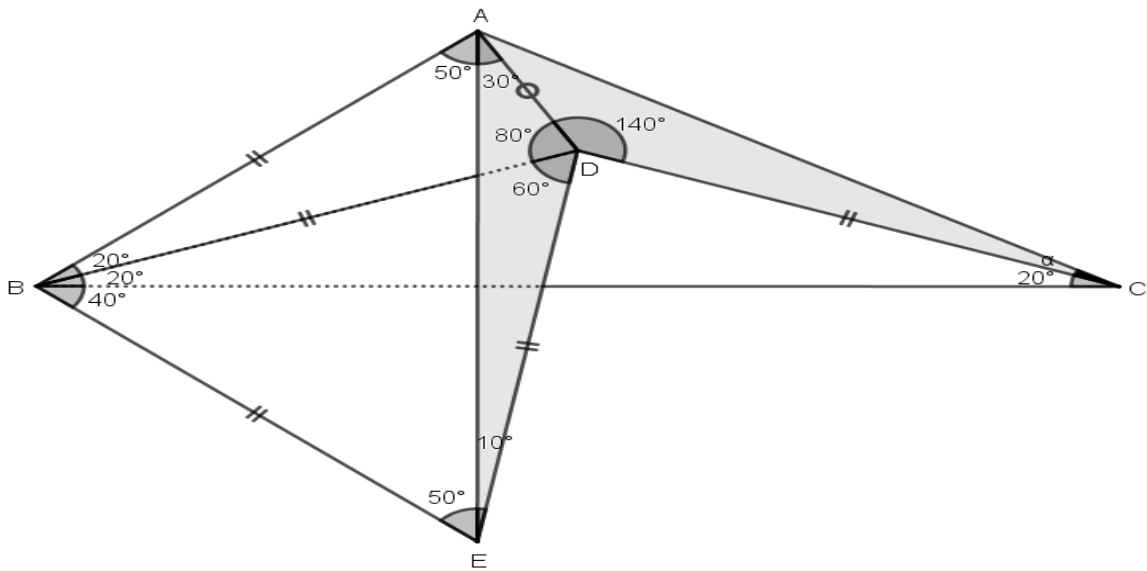

**3.2.4 Solutions:**

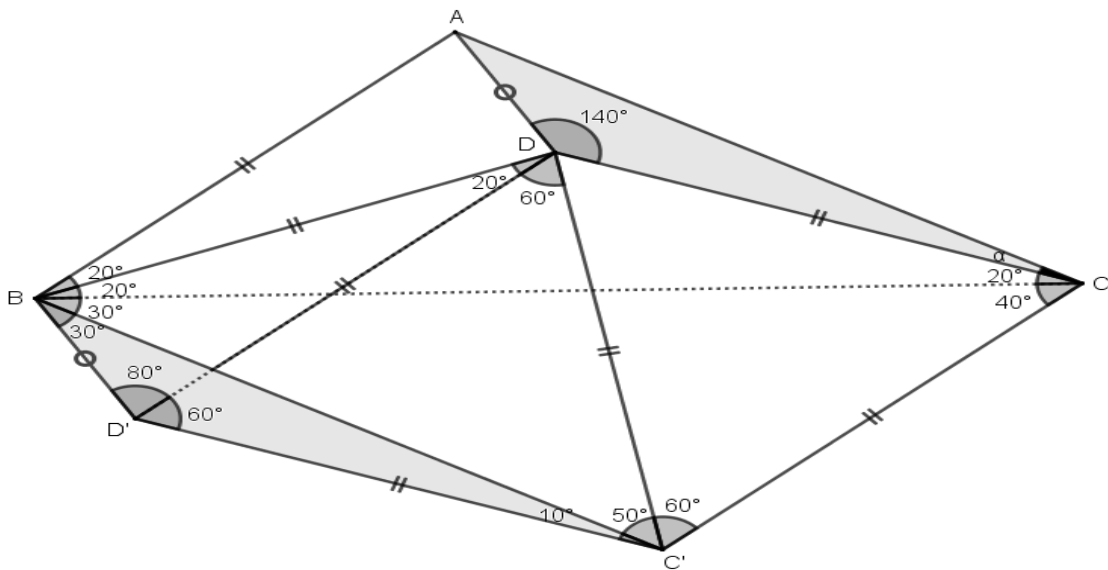

**3.2.5 Solutions:**

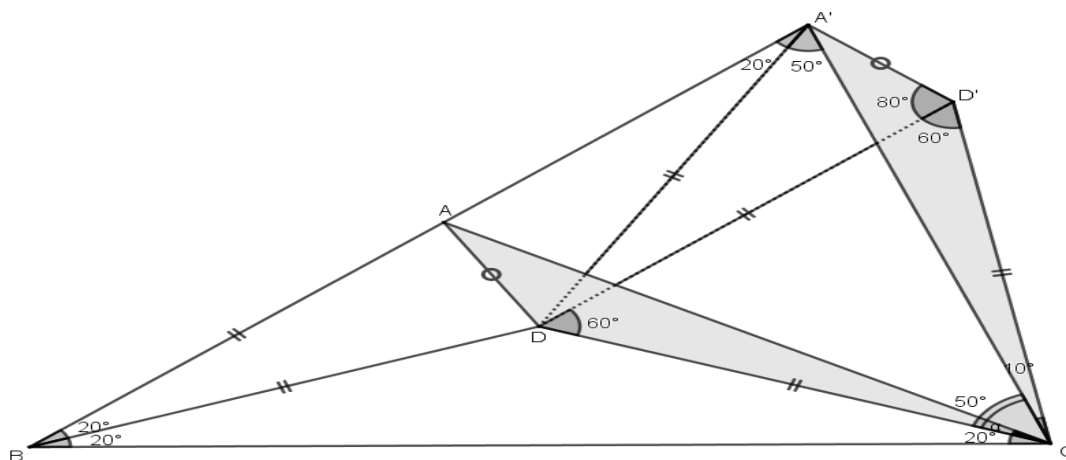

**3.2.6 Solutions:**

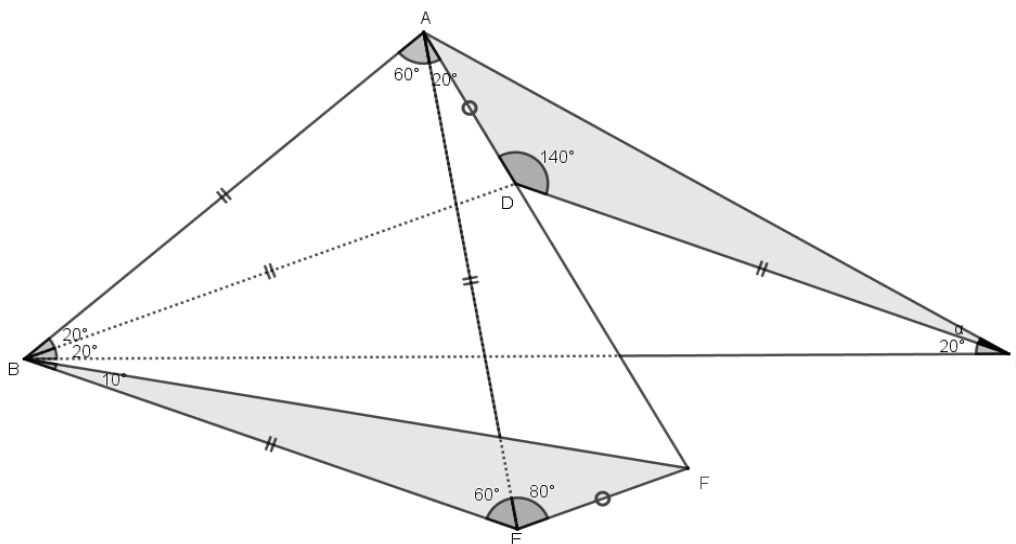

**3.2.7 Solutions:**

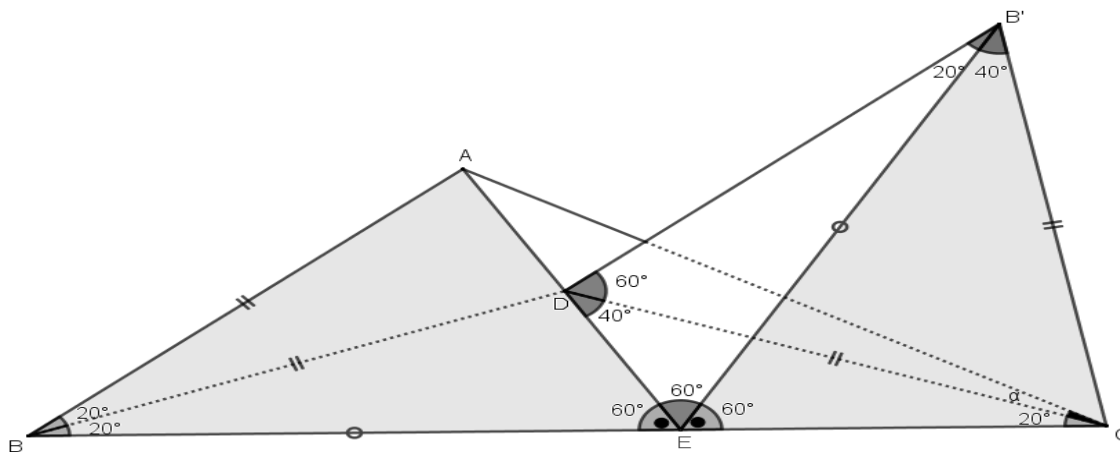



**3.2.8 Solutions:**

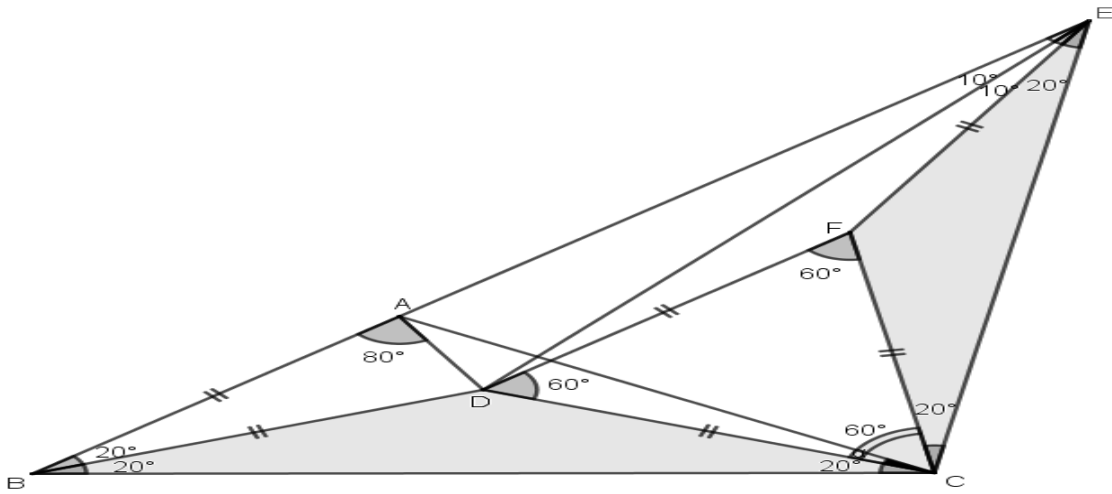

**3.2.9 Solutions:**

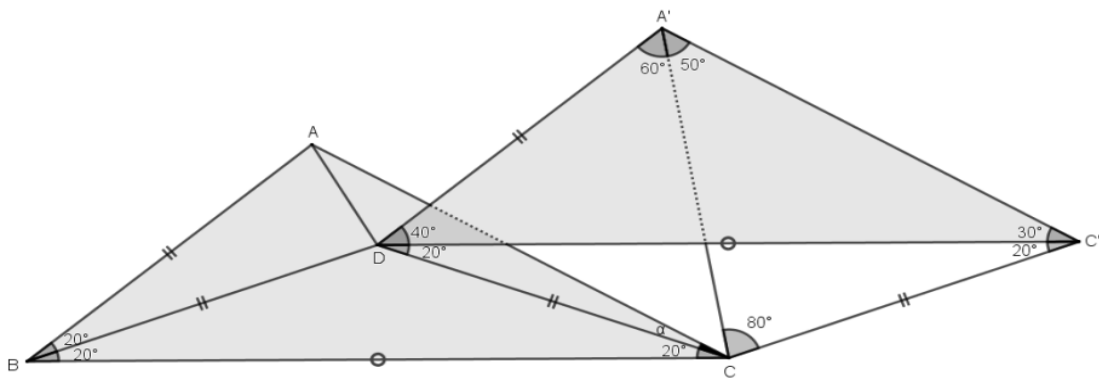

**3.2.10 Solutions:**

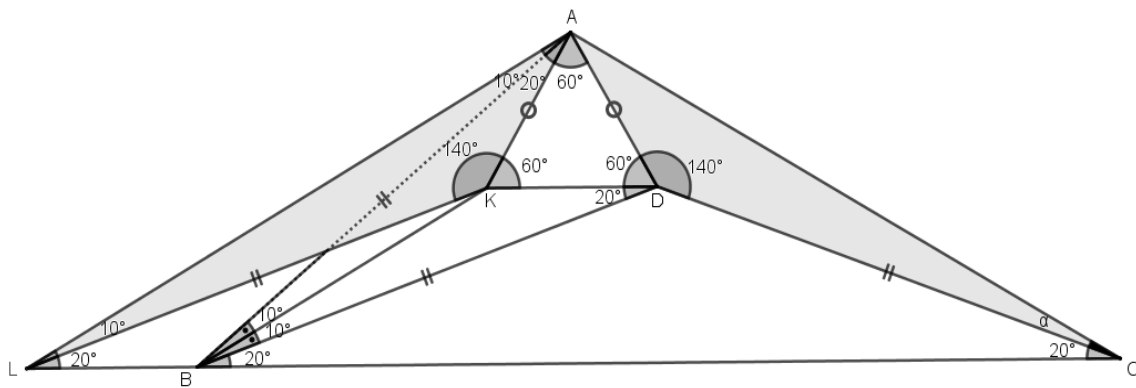

**3.2.11 Solutions:**

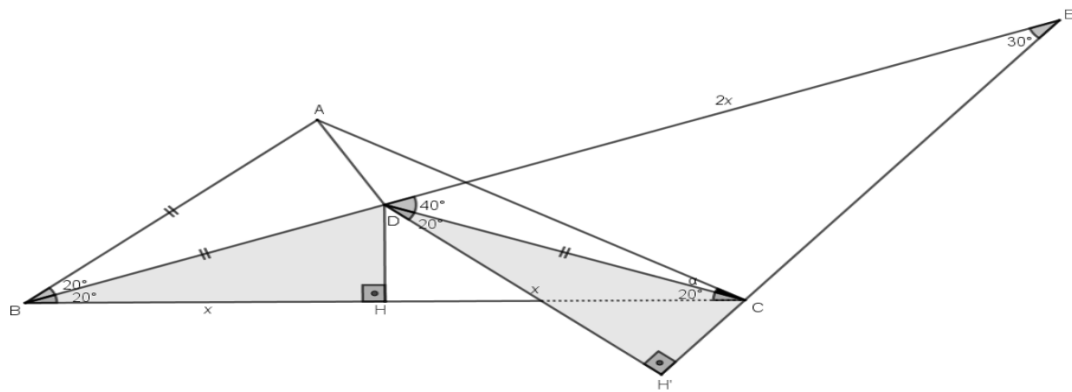

**3.2.12 Solutions:**

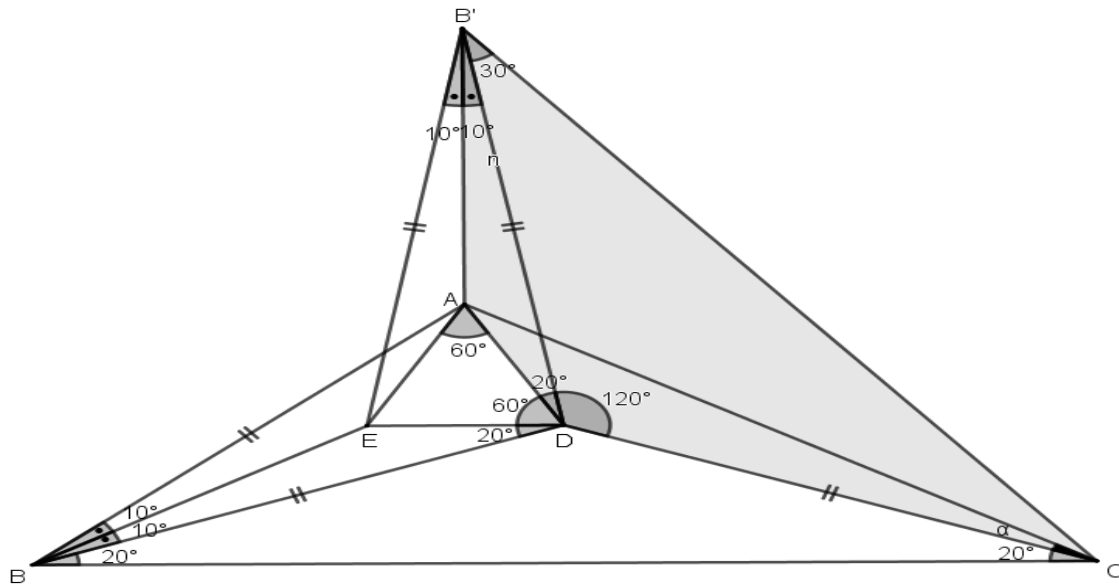

**3.2.13 Solutions:**

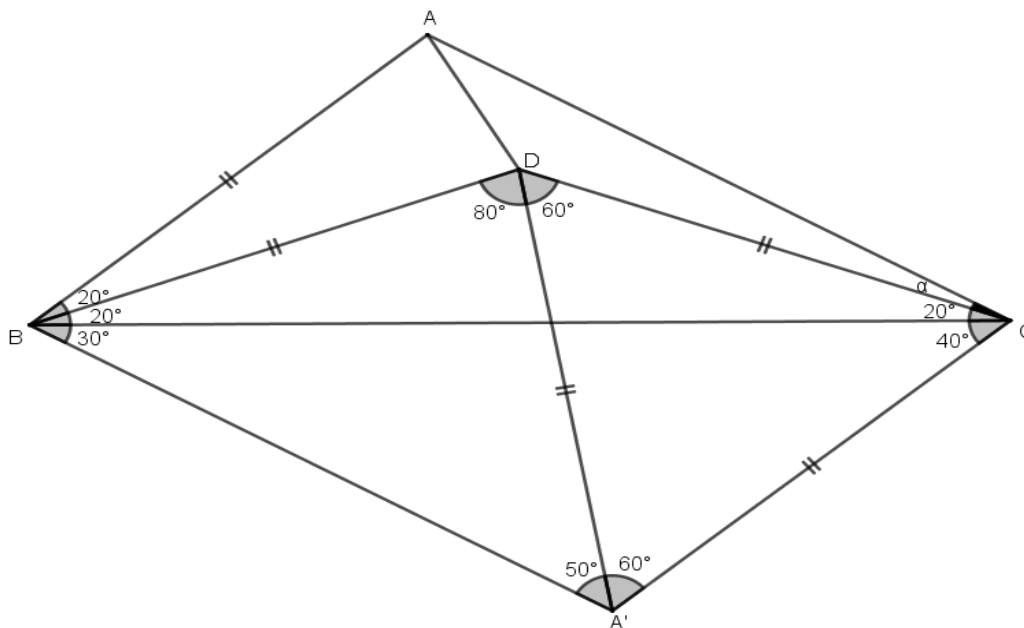

**3.2.14 Solutions:**

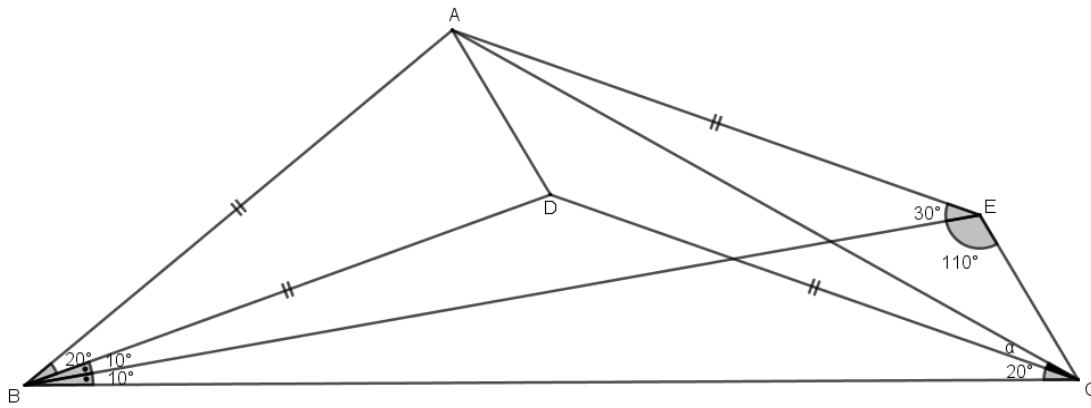

**3.2.15 Solutions:**

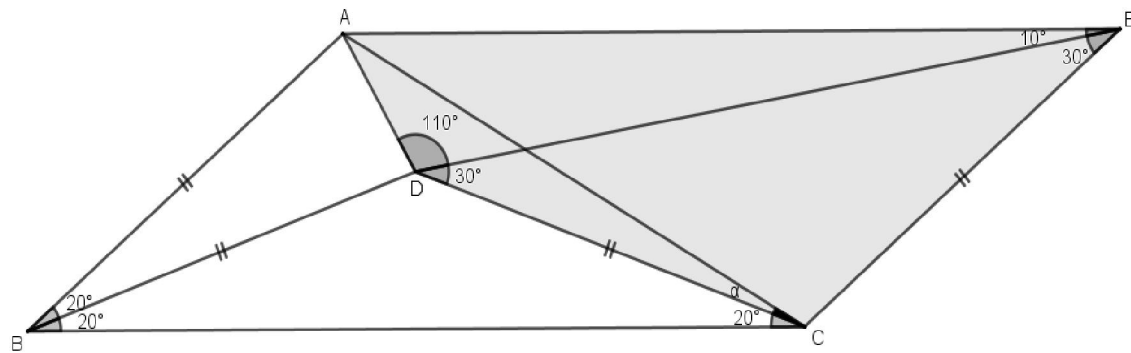

**3.2.16 Solutions:**

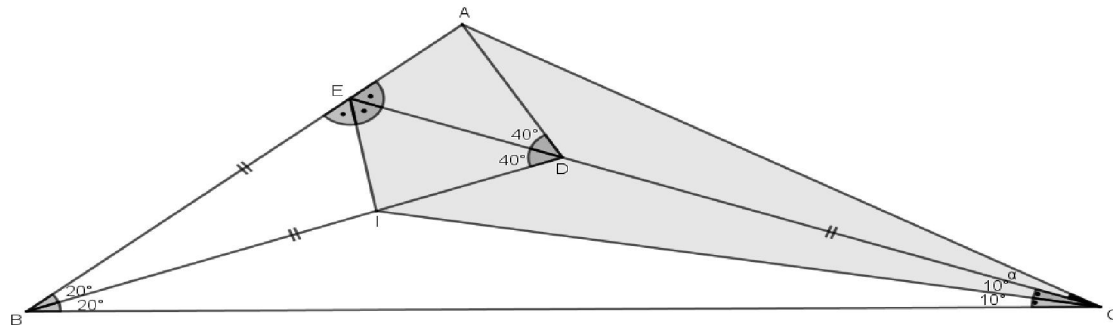

**3.2.17 Solutions:**

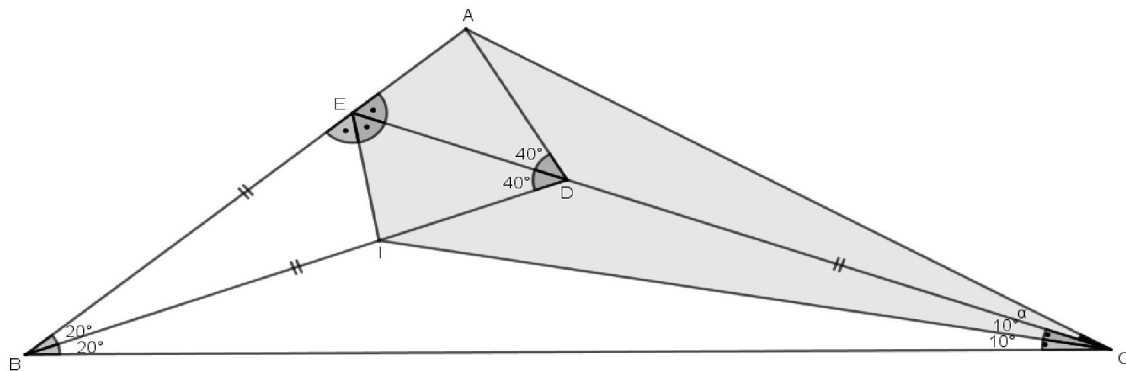

**3.2.18 Solutions:**

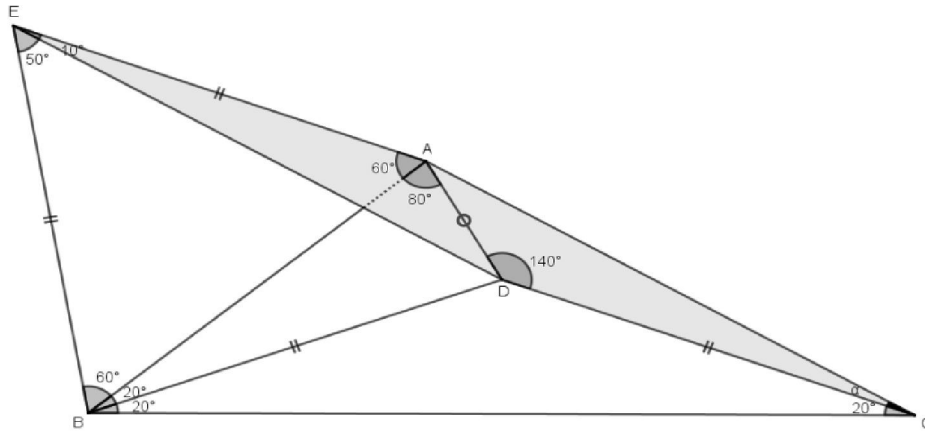

**3.2.19 Solutions:**

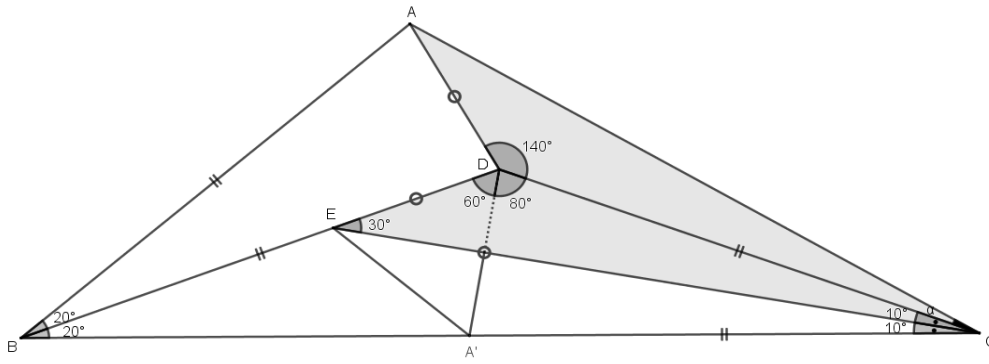

**3.2.20 Solutions:**

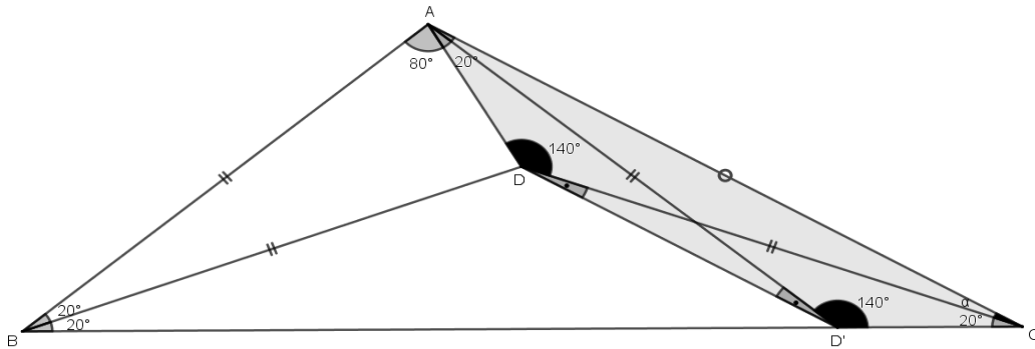

**3.2.21 Solutions:**

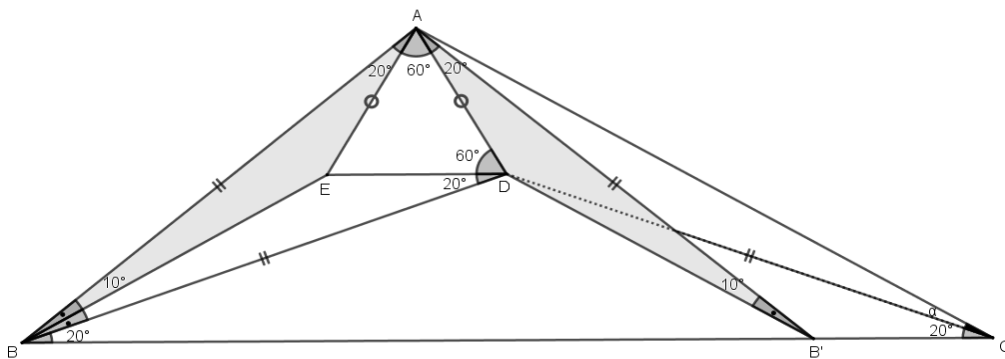

**3.2.22 Solutions:**

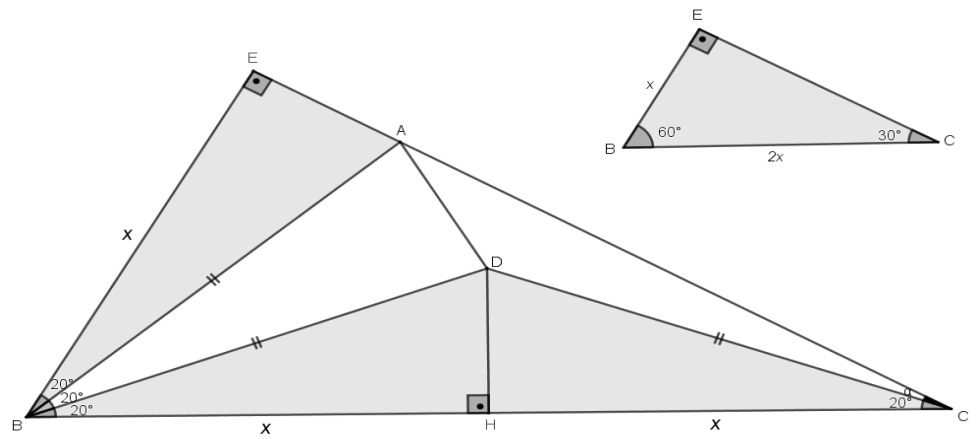

**3.2.23 Solutions:**

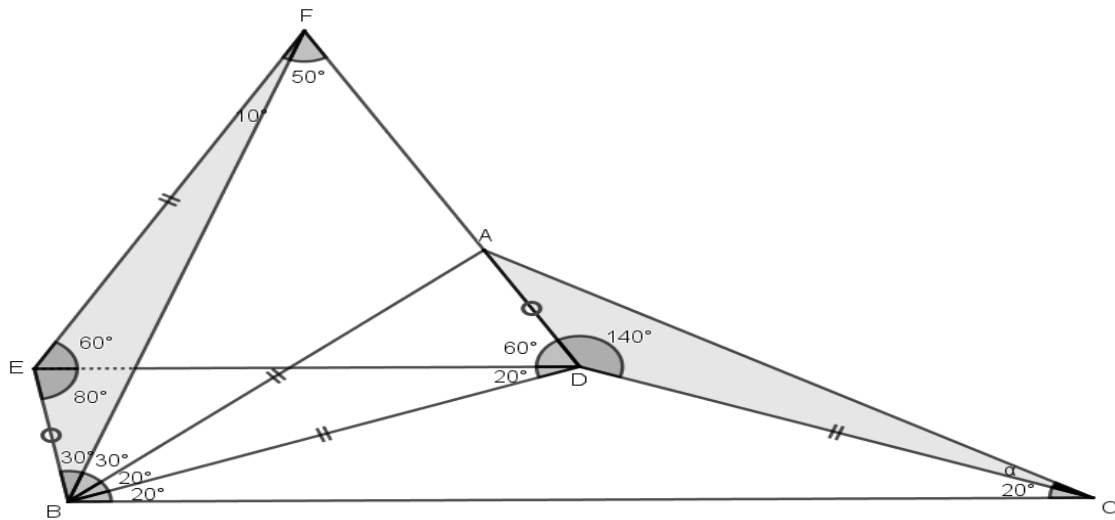

**3.2.24 Solutions:**

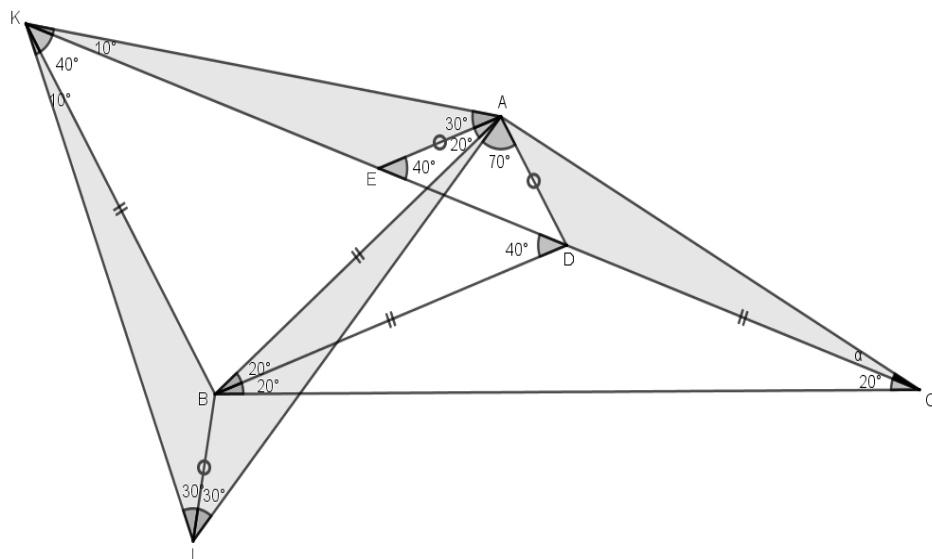

**3.2.25 Solutions:**

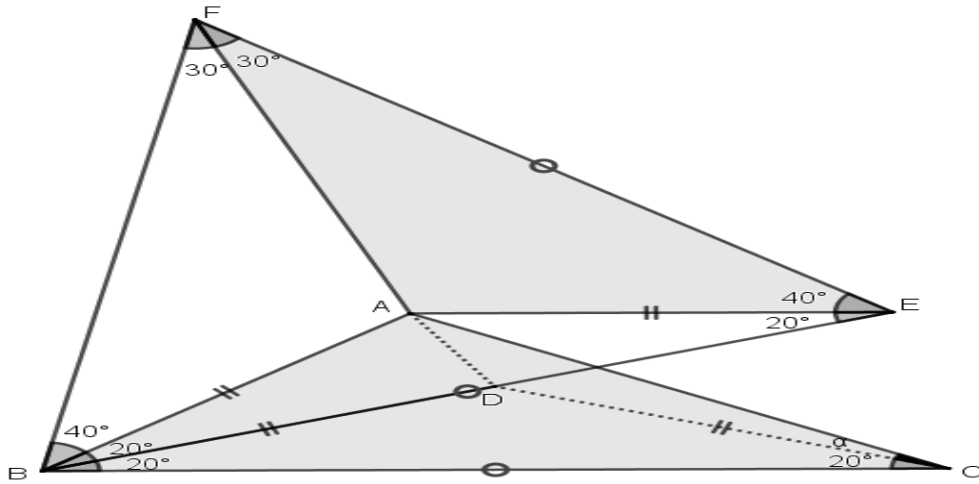

**3.2.26 Solutions:**

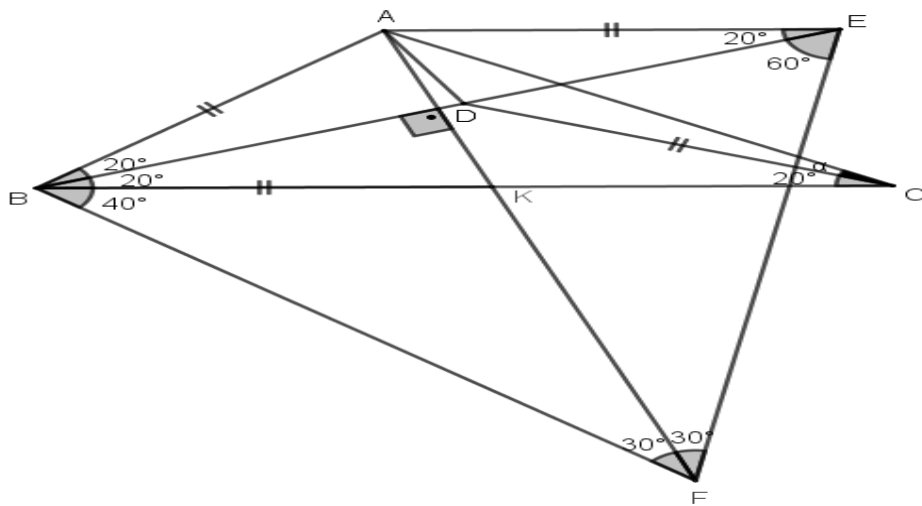

**3.2.27 Solutions:**

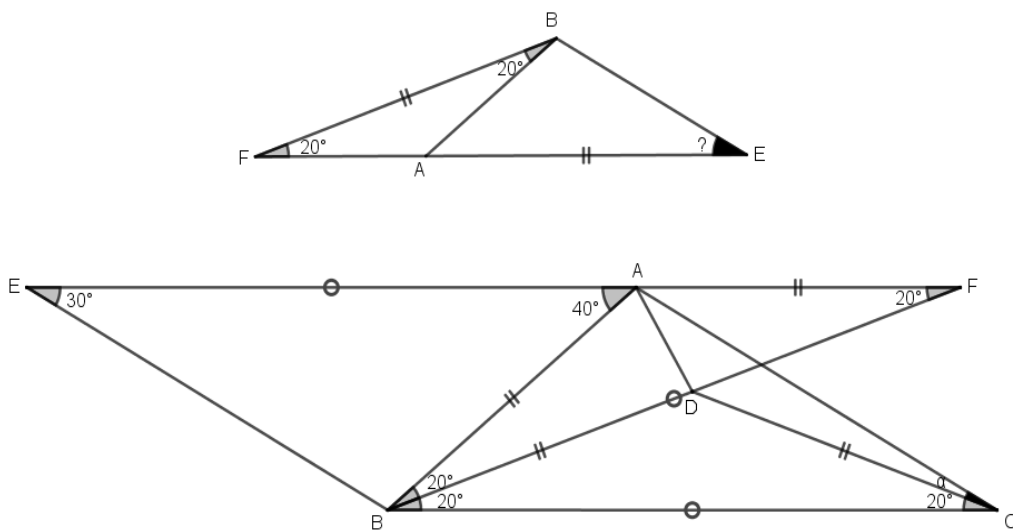

**3.2.28 Solutions:**

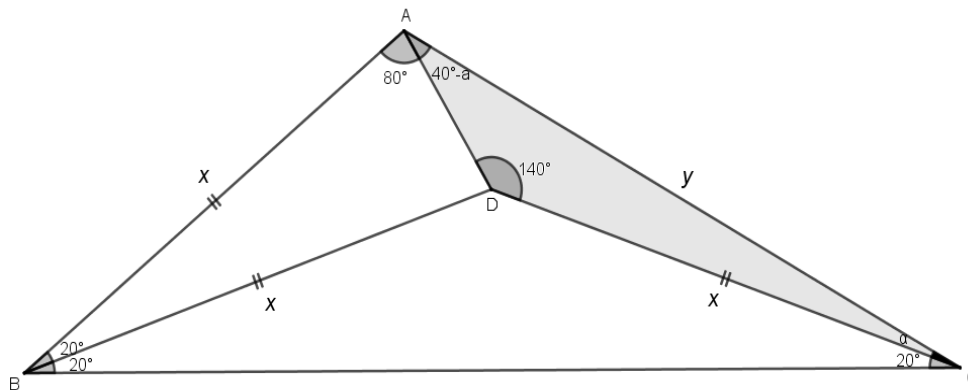

**3.2.29 Solutions:**

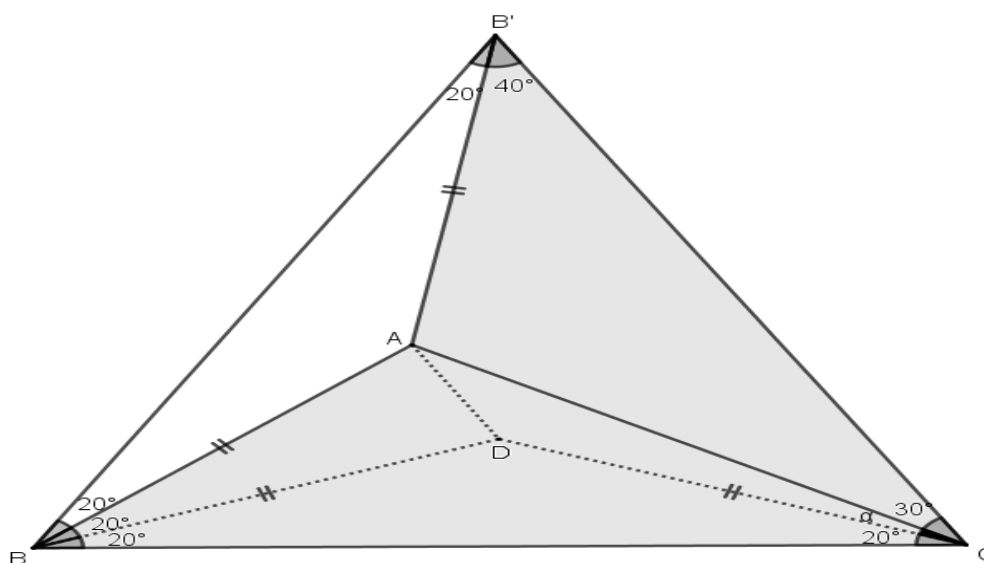

**References**

1. G. D. Birkhoff and R. Beatley, *Basic Geometry*, AMS Chelsea Publ., 2000, 3<sup>rd</sup> edition
2. D. A. Brannan, M. F. Esplen, J. J. Gray, *Geometry*, Cambridge University Press, 2002
3. J. N. Cederberg, *A Course in Modern Geometries*, Springer, 1989
4. A. De Morgan, *On the Study and Difficulties of Mathematics*, Dover, 2005
5. D. Hilbert, *Foundations of Geometry*, Open Court, 1999
6. T. Hobbes, *Leviathan*, ch. 46, Penguin Classics, 1982
7. B. Jowett, *The 3.2 Other solutions*
8. *Dialogues of Plato*, Random House, 1982
9. F. Klein, *Elementary Mathematics from an Advanced Standpoint: Geometry*, Dover, 2004
10. D. Pedoe, *Geometry: A Comprehensive Course*, Dover, 1988
11. C. Pritchard (ed.), *The Changing Shape of Geometry*, Cambridge University Press, 2003
12. S. Roberts, *King of Infinite Space*, Walker & Company, 2006
13. S.Hizarci, S.Elmas. A.Kaplan, A.S.Ipek, C.Isık, *Düzlem Geometri*,Palme Yayıncılık, Ankara,2009
14. **S.Elmas** ,**Golden Ratio in Plain and Spehere**,**International Journal Of Academic Research**, 2015
15. S.Elmas , S. Hizarci .A Different Look at the Pol Erdos-Mordell , International Journal of Science and Technology Volume 2 No. 4, April, 201
16. S.Elmas , S. Hizarci , Altın Oranın Farklı Formu ,Journal of the Fine Arts Institute (GSED),Number 38, Erzurum, 2017, 99-10

16. S.Elmas , S. Hizarci, The Golden Ratio, the Golden Number and a review on Fixed Point, *Ciencia e Tecnica Vitivinicola*. ISSN:0254-0223 Vol. 31 ,n. 12.2016.
17. Kaplan.A, Tortumlu .N,Hizarci. S, A Simple Construction of the Golden Ratio, *World Applied Sciences Journal* 7(7),833-833.2009.