

## **Development of a 4wd Prime Mover with Front Mounted Sprayer Unit for Circle Spraying of Immature Oil Palms**

**Darius EI PEBRIAN, Azmi YAHYA**

Department of Biological and Agricultural Engineering, Faculty of Engineering  
University Putra Malaysia 43400 Serdang, Selangor  
azmiy@eng.upm.edu.my

**Abstract :** A mechanized system for circle spraying palms of less than 3 years old has been developed for the oil palm plantation industry in Malaysia. This circle spraying is being carried out to every individual palms along the row and again repeated to every individual rows that are available within the field lot to be sprayed. Spraying at each individual palms is done at 1 meter radius from the palm center. A special single chassis 4WD multipurpose prime mover with a front mounted sprayer unit has been developed to mechanize this circle spraying operation. The prime mover runs on a 50.7 kW @ 2600 rpm KUBOTA V3300 water cooled diesel engine and equips with a Sauer Danfoss MPV46 axial piston pump with 210 bar maximum pressure @ 46 cm<sup>3</sup> per revolution, oscillating front and rear axles, and 12-16.5 tires with the rear tires having opposite turning direction to the front tires. Such a design configuration would provide the required traction and maneuverability for the machine system in the undulating terrain conditions. The spraying unit on the prime mover consists of a hexagonal curved boom mounted at the front of the prime mover, a 600 liters capacity polyethylene cylindrical tank at the rear, a 12V electrical SHURFLO 8000 series pump with 6.9 bar maximum operating pressure @ 6.8 liters per minutes flow, and the associated hydraulic system for the raising, lowering, opening and closing of the boom. The hexagonal curved boom is made into two equal halves frame with a hinge mechanism at the frame rear ends to facilitate for its openings and closings. Six SCX2 RB solid cone nozzles are arranged on the hexagonal curved boom structure to give a 72.5 cm equal spacing between nozzles. Both laboratory and field tests have been conducted to determine the machine traveled speed range with slippage and without slippage, the individual nozzle flow uniformity and the complete spraying pattern. Without any doubts, this mechanized system has great potential to replace the current manual method using knapsack sprayer or motorized blower for circle spraying of immature palm trees or any immature fruit trees in large scale planting. The 4WD prime mover has been designed to be used with other relevant machine attachments for seedling planting, fertilizer application, in-field collection-transportation of fresh fruit bunches and in-field collection-transportation of loose fruits for the oil palm plantation industry.

**Key words:** circle spraying, front mounted sprayer, multipurpose 4WD prime mover, field mechanization, tree crop, oil palm plantation

### **INTRODUCTION**

Weed control is a must in order to maintain the growth of immature oil palms in the field. Uncontrolled weed growth could overgrow the palms and seriously retard the tree development. For the palm to be productive, the circle area round the palm base has to be kept clear from any weed growth at all times. This circle area is about 1 m radius from the palm center at the time of planting and is expanded to about 2 m radius when the palm has reached 18 to 24 months. Such an increased in the radius is in pace with the growth of the frond canopy which is normally beyond 2 m radius from the palm center when palm age reaches 18 months (Turner and Gillbanks, 1974).

Currently, herbicides usage is the most effective approach for weed controls in the oil palm plantations. An efficient herbicides spraying team could normally cover five times the area of the same numbers of persons in manual weeding using hoe despite of giving a 40 percent increased in the weeding cost. Glyphosate, basta and paraquat are the commonly used herbicides for palms. Glyphosate and basta being classified as systemic herbicides show an efficacy of 4 to 5 days after spraying while paraquat being classified as contact herbicides show an efficacy of 2 to 3 hours efficacy (Ghani et. al, 2002).

The conventional knapsack sprayer (CKS) and semi mechanized system using controlled droplet applicator (CDA) are the common practice for circle and paths spraying in oil palm plantation in Malaysia (Orme, 2001). Before, a fully mechanized system for circle and path spraying of oil palm plantation has been introduced in the market. The system utilized a 28 hp 4WD tractor with a combination of a collapsible 27 m long rear boom sprayer unit for path spraying and a collapse curved front boom to for a circle spraying. The spraying unit consists of a diaphragm pump and a 300 liter capacity tank. However, the collapsible curve spray boom only performed when it touched the palm stems. The machine could not be used for the immature areas where the young palms have not yet developed rigid stems. Because of this, the conventional knapsack sprayer and controlled droplet applicator are being popularly used in a wide scale for circle spraying of immature palms in the plantations. Labor intensive, high labor cost per hectare and low productivity are some of the problems associated with conventional knapsack sprayer and controlled droplet applicator. There has not much technological advancement in the design of the system ever since it has been introduced in the oil palm plantations. Due its manual operation, the productivity still remains the same, whereas labor cost continues to increase with times.

The need to develop an efficient and fully mechanized system for circle spraying of palms in immature areas has been the prime interest for most oil palm plantations in Malaysia. The developed machine should be able to transverse effectively on both flat and undulating terrains of the plantations. Circle spraying operation with the machine should be fully mechanized with minimum damage to the immature palms. This paper describes on the attempt made by the researcher team at the Universiti Putra Malaysia to develop a 4WD prime mover with a front mounted sprayer unit for circle spraying of immature oil palms. The effort is part of the involvement by the team in trying to introduce "Mechanization in-totality Concept" to the Oil Palm Plantation Industry in Malaysia (Darius, 2007).

### **Prime Mover with Sprayer Attachment**

The following criteria were considered in establishing the prime mover basic design for the sprayer:

- Simple in design, construction and operation.
- Completely mechanized system for better field working environment.
- Single chassis type with articulating axles, four-wheel drive for better traction and floatation on undulating terrain.
- Four wheel steering with opposite front-rear wheel turning directions and optimum wheelbase and overall width for good in-field manoeuvrability and headland cornering in standard plantation field layout.
- Low centre of gravity for good machine stability and operator safety on inclined terrain.
- Robust in construction for good machine durability against the terrain ruggedness.
- Flexible main chassis with wide-open space for easy mounting of various implement attachments including seedling transplanter, fertiliser applicator, infield fresh fruit bunches evacuation, and infield loose fruits collection..
- Fully equipped with an auxiliary hydraulic system for running various implement attachments.

The prime mover which is to be used as the universal carrier for the various implement attachments is equipped with a 50.5 kW @ 2600 rpm water-cooled Kubota V3300 diesel engine that is directly coupled to a Sauer Danfoss serial MPV46 Axial Piston pump with displacement of 46 cm<sup>3</sup>/rev and continuous pressure of 210 bar. This hydraulic pump runs two units of Eaton 2000 hydraulic motors with displacement of 245 cm<sup>3</sup>/rev and continuous pressure of 205 bar. Each of the hydraulic motor is directly mounted to the differential gear of the axles. The close loop hydrostatic drive system has been designed with a selectable control valve that enables the prime mover to be propelled either in 2WD or 4WD mode options. The complete machine has an overall dimension of 3900 mm in length, 2000 mm in width, and 2600 mm in height. Tubular ladder structural frame has been adopted for the main chassis to support the engine and hydrostatic transmission, axles and drive wheels, driver compartment and controls, and implement attachment. The main

chassis is equipped with front and rear oscillating axles having a combination of spring and absorber suspension unit on either side to support the 12-16.5 tire. The rear portion of the prime mover has been designed to be open space to provide the mounting of the available machine attachments as per requirements. The types of machine attachments that are made available are for field transplanting of seedlings, crop fertilizing, crop spraying, and the infield fruit collection-transportation. An operator compartment has been ergonomically designed to provide an amble and comfortable space for the driver to perform all functional operations of the prime mover and the available machine attachment on the prime mover.

The circle spraying unit on the prime mover consists of a hexagonal curved boom mounted at the front of the prime mover, a 600 liters capacity polyethylene cylindrical tank at the rear, a 12V electrical SHURFLO 8000 series pump with 6.9 bar maximum operating pressure @ 6.8 liters per minutes flow, and the associated hydraulic system for the raising, lowering, opening and closing of the boom. The hexagonal curved boom is made into two equal halves frame with a hinge mechanism at the frame rear ends to facilitate for its openings and closings. Six SCX2 RB solid cone nozzles are arranged on the hexagonal curved boom structure to give a 72.5 cm equal spacing between nozzles. *Figure 1* shows the developed prototype prime mover with the sprayer attachments for circle spraying and blanket spraying.

### Prime Mover Performances

Computations were made on the theoretical travel speed of the prime mover at engine speed of 1200, 1400, 1600 and 1800 rpm when the drive wheels were running at zero slippages under both 2WD and 4WD mode options. Measurements on the theoretical drive wheel rpm at each drive wheels of the prime mover were made at the workshop with the used of a hand held tachometer when the machine front and rear axles were lifted from the ground. The required measurements were taken at the engine speed of 1200, 1400, 1600 and 1800 rpm under both 2 wheel and 4 wheel drive options. With the measured theoretical drive wheel rpm and the known drive wheel rolling radius, the measured average

theoretical speed of the prime mover at the respective engine rpm under both the 2WD and 4WD mode options were computed. These measured average theoretical speeds represent the travel speeds of the prime mover at zero wheel slippages. Determinations on the average actual travel speeds of the prime mover on asphalt surfaces were made in the field by taking the time for straight movements of the prime mover for a known distance. The required determinations were made at the engine speed of 1200, 1400, 1600 and 1800 rpm under both 2 wheel and 4 wheel drive options.

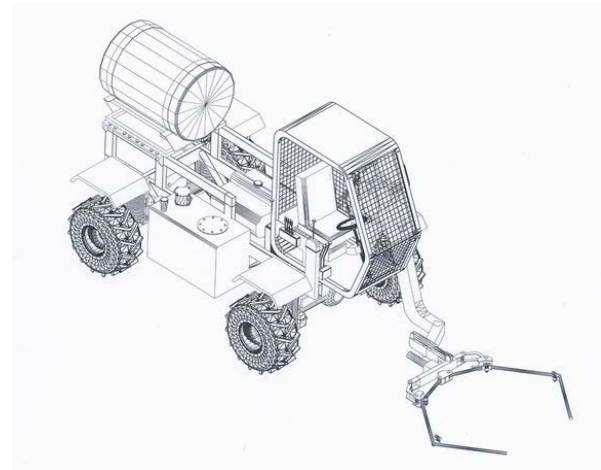

**Figure 1. The developed 4WD prime mover with the sprayer attachments**

*Table 1* shows the prime mover performances under 2WD and 4WD mode options. The proportion of measured over computed theoretically speed basically represents the efficiency of the hydrostatic drive system of the prime mover. While, the proportion of the difference between the measured average actual travel speed and measured average theoretical speed over the measured average theoretical speed represents the average drive wheel slippage of the prime mover on the tested running terrain. Observed that the measured average theoretical speed and the measured average actual travel speed of the prime in the 2WD option were in the range of 1.95 to 2.12% and 1.88 to 1.92% higher than in the 4WD option. The hydraulic efficiencies for the prime mover ranges from 81.83 to 84.79% while having not much efficiency differences under both drive mode options. The average drive wheel

slippages for the prime mover were respectively in the range of 8.27 to 11.76% and 4.82 to 6.17% under 2WD and 4WD mode options on the tested asphalt running surfaces; average reduction in the range of 3.45 to 4.93% under 4WD mode option. No specific trends were found in the hydraulic efficiencies and average drive wheel slippages of the prime mover with the engine speeds under both drive mode options.

### Spraying Characteristics

The sprayer was tested in the laboratory for the nozzle spraying angles, swath, flow rates and overall spray distribution. The sprayer boom was set to spray at 60 cm height from the ground level in a closed room. The nozzles on the spray boom were

numbered from 1 to 6 in a clockwise direction. A catch container was placed beneath each available nozzle on the spray boom. The spray delivered by the respective nozzles was measured and recorded for a time period of 15 seconds. The spray angles from each individual nozzle was also measured and recorded. The spray swath was computed from the known values of the spray angles and spraying height. Table 1 shows the nozzle spraying characteristics. Generally, spray swath increased with increasing of spray angles and increasing of spray flow rates. The smallest spray swaths were with nozzles 1 and 6 where the spray angles and flow rates were minimised. This occurred because both the nozzles were located at the end of the sprayer line. The spray swath of the respective nozzles as per the nozzle position on the hexagonal curved boom was drawn to scale for the purpose of determining the spraying circle diameter.

Table 1. Prime mover performances under 2WD and 4WD options

Drive mode option	Engine speed, rpm	Computed theoretical travel speed, km/hr	Measured average theoretical speed, km/hr	Measured average actual travel speed, km/hr	Proportion of measured over computed theoretical speed, %	Proportion of the difference between measured average actual travel speed and measured average theoretical speed over the measured average theoretical speed, %
2WD	1200	8.42	6.89	6.32	81.83	8.27
	1400	9.82	8.33	7.35	84.82	11.76
	1600	11.23	9.22	8.31	82.10	9.87
	1800	12.63	10.58	9.55	83.77	9.82
4WD	1200	4.21	3.53	3.36	83.85	4.82
	1400	4.91	4.14	3.83	84.32	7.49
	1600	5.61	4.66	4.43	83.07	4.94
	1800	6.31	5.35	5.02	84.79	6.17

The spraying area per palm for the sprayer is computed as follows :

$$A_c = \frac{1}{4} \pi D^2$$

where:

$A_c$  = Spraying area per palm, m<sup>2</sup>

$D$  = Spraying circle diameter, m

Having  $D = 2.40$  m, the computed values of  $A_c = 4.53$  m<sup>2</sup>.

The total spraying area covered by the sprayer is computed as follows :

$$S_p = \frac{A_c \times P}{10000}$$

where:

$A_c$  = Spraying circle area, m<sup>2</sup>

$P$  = Palm density, palms per hectare

Having  $A_c = 4.53$  m<sup>2</sup> and  $P = 148$  palms/ha, the computed value of  $S_p$  is 0.067 ha.

The sprayer actual field application rate per hectare by the sprayer is computed as follows :

$$V_a = V_r \times S_p$$

where:

$V_r$  = Recommended application rate per hectare, l/ha

$S_p$  = Spray area per hectare, ha

Having  $S_p$  is 0.067 ha and  $V_r = 600$  l/ha, the computed value of  $V_a$  is 40.2 l/ha.

The sprayer application rate per palm is computed as follows :

$$A_p = \frac{V_a}{P}$$

where:

$A_p$  = Application rate per palm, l/palm

$V_a$  = Application rate per hectare, l/ha

$P$  = Palm density, palms per hectare

Having  $V_a = 40.2$  l/ha and  $P = 148$  palms/ha, the computed value of  $A_p$  is 0.2716 l/palm.

The hexagonal curved boom has a total of 6 nozzles and the average flow rate of each individual nozzle is about 880 ml/min. Thus the total flow rate

from all the available nozzles on the curved boom is 5280 ml/min.

The expected spraying time per palm can be computed as follows:

$$T = \frac{A_p \times 60 \times 1000}{N_q}$$

where:

$T$  = Spraying time per palm, sec

$A_p$  = Application rate per palm, l/ha

$N_q$  = Total nozzle flow rate, ml/min

Having  $A_p$  is 0.2716 l/palm and  $N_q$  is 5280 ml/min, the computed value of  $T$  is 3 seconds.

On the basis of the above calculations, the timer switch that has been wired to the 12V electrical SHURFLO 8000 series pump was set to run the pump for 3 seconds whenever the switch was triggered for circle spraying.

**Table 2. Nozzle spraying characteristics**

Nozzles number	Spray angle, degree	Spray swath, cm	Flow rate, l/min
2	80 <sup>a</sup>	100.69 <sup>a</sup>	0.980 <sup>a</sup>
5	79.33 <sup>a</sup>	100.69 <sup>a</sup>	0.976 <sup>a</sup>
3	78.67 <sup>a</sup>	98.34 <sup>a</sup>	0.966 <sup>a</sup>
4	78.33 <sup>a</sup>	97.17 <sup>a</sup>	0.960 <sup>a</sup>
6	73.33 <sup>b</sup>	89.39 <sup>b</sup>	0.707 <sup>b</sup>
1	70 <sup>c</sup>	84.02 <sup>c</sup>	0.693 <sup>b</sup>

Means in a given column followed the same letter and numbers are not significantly different at the 0.05 level determined by DMRT.

### Spray Pattern Uniformity

Controlled laboratory test was conducted on the sprayer to determine the uniformity of its spray pattern onto the targeted area. A total of 49 Petri disks were arranged on the laboratory floor at 30 cm equal square spacing grids to cover a total area 180 cm<sup>2</sup>. The sprayer boom was at the centre of the prepared catchment's area and positioned to spray at 60 cm height from the floor level. The spraying time was set for 3 seconds and the collected spray droplets in each individual Petri disks were weighted. Surfer 7 software was used to produce the contour map of the spray distribution for the catchment's area. *Figure 2*

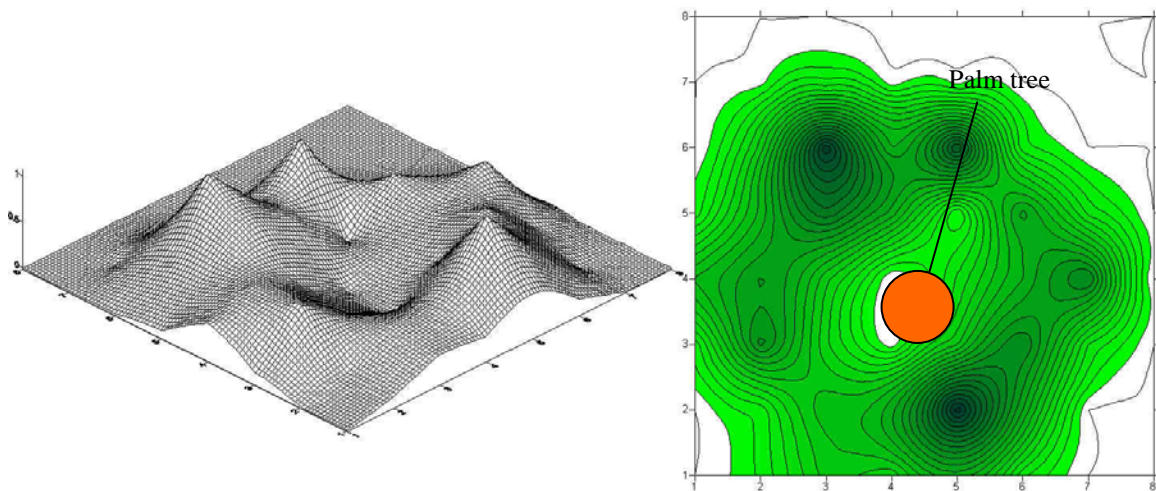

Figure 2. Pattern of uniformity of spray distribution

shows the typical contour map for the spray pattern for the sprayer as the result from the laboratory test. Green colored shows the spray distribution on targeted spraying area while the orange colored circle represents the palm trunk. Generally, the sprayer was able to distribute the spray droplets uniformly onto the targeted area. Higher spray distribution was found exactly below the each nozzle positions as indicated in the produced wireframe map. Overall, the sprayer was able to produce a spraying swath of about 2.1 m width and a circle spray area of about 3.46 m<sup>2</sup>; a difference of about 76.4 percent from the earlier computed value. The resultant total spraying swath and spraying area could be considered good enough to accommodate the requirement for the immature

palms spraying. The "Good Agriculture Practice" or GAP in the oil palm plantation in Malaysia for immature palms spraying is within diameter 1.5 m to 1.8 m circle diameter.

#### CONCLUSIONS

A 4WD prime mover with front mounted spraying unit for cycle spraying had been successfully been designed, fabricated and calibrated for the oil palm plantation in Malaysia. This mechanized system shows potential to replace the current manual method using knapsack sprayer or motorized blower for circle spraying of palms in large scale planting.

#### REFERENCES

- Darius El Pebrian and Azmi Yahya. 2007. A New Concept of Integrated Mechanization System for the Oil Palm Plantation Industry in Malaysia. Paper Presented at the Int'l Conf. on Crop Harvesting and Processing, Kentucky, Feb 11-14.
- Ghani, E.A, M.T. Dolmat, M.B Wahid. 2001. Planting and Maintenance of Oil Palm for Small Holder Sector. (in Bahasa Malaysia). MPOB, Kuala Lumpur. Malaysia.
- Orme, A. 2001. Evolving a New Estate Practice for Circle and Path Spraying. Libero. Kuala Lumpur. Malaysia.
- Turner and Gillbanks. 1974. Oil Palm Cultivation and Management. Incorporated Society of Planter, Kuala Lumpur. Malaysia.