

Improving the Power Quality of Wind Power Plants through Modifying the Instantaneous Active and Reactive Power Theory

Mahdi Heidari *

*Department of Electrical Engineering, Faculty of Engineering, University of Zabol, Zabol, Iran
(m.heidari@uoz.ac.ir)

‡Corresponding Author; Mahdi Heidari, Department of Electrical Engineering, Faculty of Engineering, University of Zabol, Zabol, Iran, Tel: +98 915 144 9103,

Fax: +98 54 3123 2020, m.heidari@uoz.ac.ir

Received: 09.04.2015 Accepted:24.05.2014

Abstract- One of the most important issues regarding clean energy is considered to be clean electricity generation with desirable quality. Low quality electricity causes the losses increase, mis-operation of the protection relays, saturation of iron core transformer amongst others. Hence, it seems necessary to supply electricity with acceptable quality satisfying related standards such as IEEE-519. The quality of the power generated by wind turbines should be investigated in order to adopt some strategies-if needed- to improve its performance. A wind turbine is connected to the grid through a converter. Traditional converters are fixed-speed whereas the advanced systems are variable-speed. The most important advantage of the advanced systems is related to the mitigated mechanical stress and the energy capacity increase. Rectifier and inverter are involved in the topology of variable-speed machines. This paper presents a mathematical model of this system i.e. a variable speed machine which is defined in the rotating reference frame of rotor. Rectifiers and inverters contain some power electronic elements which are the major causes of harmonic generation because of their nonlinear characteristics. Harmonics are considered as one of the most important phenomena decreasing the power quality. Therefore, mitigation of the harmonic seems necessary. The shunt active filter is used to reduce the current harmonics. This filter has three components, namely identification, modulation and inverter. Some of the identification methods are sensitive to the input voltage harmonics. So, an algorithm which shows the better performances has been used in the identification part. Finally, performance of the mentioned filter has been proved through the simulation.

Keywords Wind turbine, theory of instantaneous active and reactive power, filter, harmonic.

1. Introduction

Wind turbine is one of the renewable energy power plant developing fast [1] such that since 2004, the installed capacity of wind generation in the world has increased by 20% [2]. Because of some reasons such as the tower shadow and the wind conditions, power output of the wind power plants is variable [3]. Therefore, utilization of methods which can increase the wind power output is being important. Wind energy conversion systems may be divided into fixed-speed and variable-speed systems [4]. The former has some advantages like simplicity, reliability and low cost of the electrical components. However, factors such as the lack of the consumed reactive power control, mechanical stress and

poor power quality are major disadvantages of this type of conversion system [5] causing a decrease in the application of this system in recent years. Recently, the variable-speed conversion system has had a dominant position and the better performance of them has been demonstrated as it works in the wide range of speed. This system, in contrast to the fixed speed one, keeps the generator torque relatively constant and also the fluctuation of wind is taken into account by adjusting the generator speed [5]. Hence, compared with the fixed speed wind turbines, power quality of the variable speed wind turbines can be more controllable. Of the other advantages are less mechanical stress and more capability of the energy storing [6]. In these structures, power electronic converters are usually used. So, the higher cost and electrical

losses are also introduced as disadvantages [5]. In addition, due to the nonlinear characteristic, power electronic converters are the main causes of the generated harmonics in the grid that not only increase the losses, but also have major role in decreasing the power quality. In order to make reduction in the harmonics, passive filters were used in the past. In these filters, the specific harmonics are eliminated using the selection of the passive elements such as inductor and capacitor in proper sizes. The main drawback of these filters is the resonance occurring between the passive elements and grid impedance [7]. In order to avoid the problems of resonance, the idea of using the active filters was introduced by Sasaki and Machida [8]. In these filters, main signals of the system are sampled. Based on the sampling data, a current or a voltage is injected to the system in series or parallels, respectively to mitigate the harmonic emerged in the system. Active filters have three main parts called identification, modulation and inverter. Among the topics found on the active filter operation, the methods for generation of the reference signals have an important role in affecting the speed and the accuracy of the response. These methods are mainly divided in two categories: time domain and frequency domain [9]. Using the time domain based methods leads to faster operation where the higher accuracy is achieved by the frequency domain based methods. Some of the time domain based approaches such as p-q transformation (theory of instantaneous active and reactive power) have not significant performance in the presence of harmonic sources. This fact will be shown using mathematical analyses. In this paper, a time domain based method which avoids the above mentioned problem has been used.

Variety of the wind turbines are presented in section 2. A comprehensive and detailed analysis for the system of case study with instruction of its circuit model is demonstrated in section 3. Section 4, has analysed the proposed active filter considering suggested modification, for improving the performance, in detail. The results obtained by computer simulation of the proposed system are shown in section 5.

1. Types of wind turbine

Nowadays, regarding the actual price of energy, utilization of the relatively inexpensive energies is an inevitable fact. Therefore, wind energy is increasingly becoming more important. In [4-6], four types of wind turbines have been introduced whose systems which make the proper interference between the wind turbine and the grid are as following:

1. Squirrel Cage Induction Generator (SCIG) with Soft Starter (SS)
2. Wound Rotor Induction Generator (WRIG) with variable rotor resistance and SS
3. Double Fed Induction Generator (DFIG) with power electronics converter
4. Permanent Magnet Synchronous Generator (PMSG) with power electronics converter

In the first type, a SCIG is connected to the wind turbine. Soft connection is obtained by an SS. Since this

model consumes high amount of reactive power, capacitor banks may be installed at the terminals of the generator due to the reactive power compensation. It should be noted that this model is a fixed-speed wind turbine. A typical schematic of this model is shown in Fig.1.

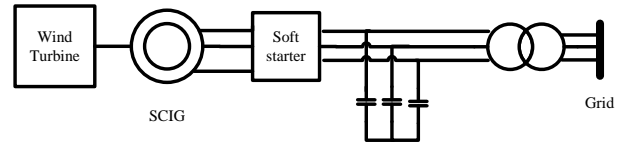

Fig. 1. Conversion system of wind turbine with SCIG and SS

Type 2 allows the wind turbine to be connected to the WRIG and also an SS. Similar to that of type 1, the capacitor banks are installed at the generator terminals for the purpose of compensating the reactive power. In the presence of variable rotor resistance, it is possible to control the generator speed in the specific ranges dependent on the value of the resistor. Usually, designing assumptions are determined in such a way that they allow the generator speed to approximately be 0-10 % higher than the synchronous speed. Fig.2 shows the structure of this system.

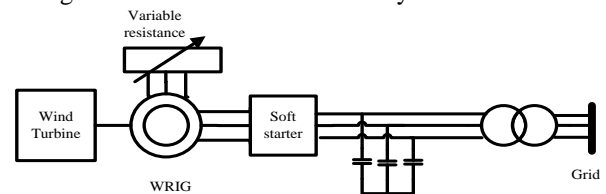

Fig. 2. Conversion system of wind turbine with WRIG, variable rotor resistance and SS

Capacitor banks cause the undesired effects including transient and sub synchronous resonances. Furthermore, since they are adjusted in a discreet region, they may be able to inject not every amount of the required reactive power. Therefore, power electronic devices have been used in the configuration of type 3 and also type 4 to isolate the generator from the grid. Consequently, the generator speed will not be limited by the grid frequency and the reactive power will be fully controlled. In type 3 of wind energy conversion systems known as DFIG, the stator of the induction generator is directly connected to the grid through a transformer, while its rotor is connected to the grid using a power electronic converter. The block diagram of this scheme is shown in Fig. 3. In the fourth type, an electrical machine called PMSG is used. The rotor and stator of this machine are connected to the wind turbine and two back- to- back converters, respectively. The structure of this system is presented in Fig. 4.

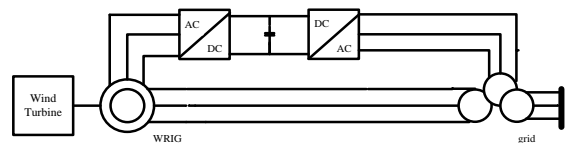

Fig. 3. Conversion system of wind turbine with DFIG and power electronic converters

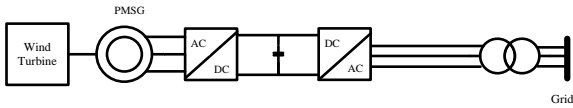

Fig. 4. Conversion system of wind turbine with PMSG and power electronic converters

Sometimes, wind turbines are assumed in the islanding mode i.e with no connections between turbine and grid, in order to analyze the harmonics [6]. The basics of the proposed diagram reported as such are shown in Fig. 5.

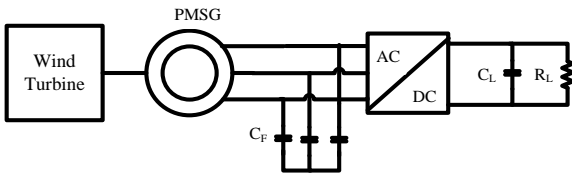

Fig. 5. studied system

2. Studied system

The main parts of a wind power plant are the wind turbine, permanent magnet generator and ac to dc converter (rectifier). In this section, wind turbine has been introduced at first. Next, a mathematical model of the elements of the wind energy conversion system in the rotor rotating reference frame is represented. So, the generator current and then ac to dc converter current are calculated.

3.1. Wind turbine

Wind turbine is described by the curve of the non-dimensional power coefficient C_p as a function of the speed ratio λ [10]. The speed ratio is the ratio of the linear speed of the turbine to the wind speed. In other words,

$$\lambda = \frac{r\omega_m}{V_w} \tag{1}$$

In Eq. (1), r is the rotor radius, ω_m is mechanical angular speed of the rotor and V_m is the wind speed. The relation between the power coefficient and the tip speed ratio is shown in Eq. (2) [11].

$$C_p = 0.043 - 0.108\lambda + 0.146\lambda^2 - 0.0602\lambda^3 + 0.0104\lambda^4 - 0.0006\lambda^5 \tag{2}$$

The output power of wind turbine is calculated using Eq. (3) [12].

$$P_t = 0.5C_p(\lambda)\rho AV_w \tag{3}$$

where ρ is the air density(kg/m^3) and A is the area of wind wheel(m^2). Torque produced by the wind turbine is determined trough dividing the output power by the mechanical angular speed.

$$T_t = \frac{P_t}{\omega_m} \tag{4}$$

Combining Eq. (3) and Eq. (4) results the wind turbine torque as following:

$$T_t = 0.5\rho AC_p(\lambda)\frac{V_w^3}{\omega_m} = 0.5\rho Ar\frac{C_p(\lambda)}{\lambda}V_w^2 \tag{5}$$

$$T_t = 0.5\rho ArC_T(\lambda)V_w^2 \tag{6}$$

Where, $C_T(\lambda)$, the torque factor, is the power coefficient to speed ratio. The curve of torque factor with respect to the speed ratio is depicted as Fig. 6 [6].

$$C_T(\lambda) = \frac{C_p(\lambda)}{\lambda} \tag{7}$$

After calculating the parameters related to the wind turbine, the converter system will be considered and the corresponding equations will be expressed. In the first step, characteristics of PMSG is given followed by those of the converter.

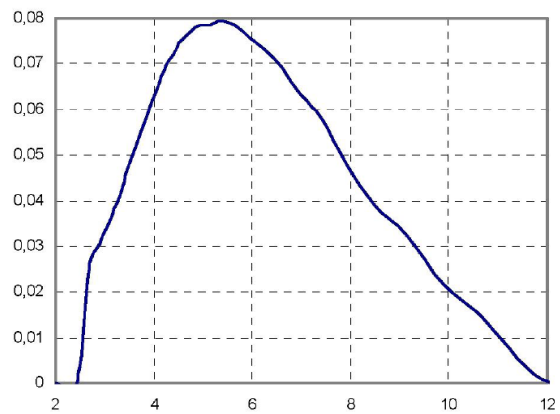

Fig.6. The curve of torque factor with respect to the speed ratio

3.2. Permanent Magnet Synchronous Generator (PMSG)

The wind turbine drives PMSG whose terminal voltage equation is described as Eq. (8) [13].

$$[V_{abc}^g] = -[R_{abc}^g][i_{abc}^g] + p[V_{abc}^g] \tag{8}$$

By transforming these voltages to the dqo frame we have

$$\begin{aligned} V_q^g &= -(R^g + pL_q^g)i_q^g - \omega_r L_d^g i_d^g + \omega_r \lambda_m \\ V_d^g &= -(R^g + pL_d^g)i_d^g - \omega_r L_q^g i_q^g \\ V_o^g &= 0 \end{aligned} \tag{9}$$

Where, R_g is the stator resistance, L_d and L_q are the inductance in d-axis and q-axis, respectively. ω_r is the angular speed of the generator, λ_m is the stator linkage flux and p is the differential operator.

Under the assumption that the stator voltage is a pure sinusoidal wave with amplitude of V_s^g , we have

$$\begin{aligned} V_a^g &= V_s^g \cos(\theta_r) \\ V_b^g &= V_s^g \cos(\theta_r - \frac{2\pi}{3}) \\ V_c^g &= V_s^g \cos(\theta_r + \frac{2\pi}{3}) \end{aligned} \tag{10}$$

These voltages is appeared as time invariant terms by transforming them to the rotor rotating reference frame.

$$V_q^g = V_s^g \tag{11}$$

$$V_d^g = 0 \tag{12}$$

Practically, one can say $L_q^g = L_d^g = L^g$ for a PMSG [14]. Therefore, the relation between the current in d and q axis can be determined by substituting Eq. (12) in the second equation of Eq. (9). Then, the voltage in q-axis is calculated using the first equation of Eq. (9) as expressed in Eq. (13).

$$V_q^g = -\left[\frac{(R^g + pL^g)^2 + \omega_r^2 (L^g)^2}{R^g + pL^g} \right] i_q^g + \omega_r \lambda_m \tag{13}$$

The term $\omega_r^2 (L^g)^2$ is negligible in comparison with $(R^g + pL^g)^2$. Hence, with acceptable accuracy, Eq. (14) is obtained by substituting Eq. (11) in Eq. (13).

$$V_s^g = (R^g + pL^g)^2 i_q^g + \omega_r \lambda_m \tag{14}$$

This equation represents the relation between the stator voltage and current and linkage flux in the assumed machine. According to Fig. 5, after describing the PMSG machine, the converter is, in turn, presented.

3.3. AC to DC converter

The output voltage of a typical rectifier has been expressed in Eq. (15)

$$V_R = \frac{3V_s}{\pi - 3\mu} \left[\left(\frac{\sqrt{3}}{2} - \frac{3}{2} \sin \mu + \frac{\sqrt{3}}{2} \cos \mu \right) * \cos \alpha + \left(\frac{3}{2} - \frac{\sqrt{3}}{2} \sin \mu - \frac{3}{2} \cos \mu \right) * \sin \alpha - 2l_{co} p I_R \right] \tag{15}$$

Where, α is the delay angle, μ is the commutation angle, l_{co} is the commutation inductance, I_R is the current of the rectifier and V_R is the dc output voltage. Neglecting the commutation, the term describing the rectifier output voltage will be simple as expressed Eq. (16).

$$V_R = \frac{3\sqrt{3}}{\pi} V_s \cos \alpha \tag{16}$$

The cosine of angle between V_s and fundamental harmonic of the current in ac side can be approximated with the cosine of the delay angle [11].

$$\cos \alpha = \cos \varphi \tag{17}$$

Neglecting the rectifier losses, the power in the ac and dc side are equal. Consequently,

$$V_R I_R = v_a i_a + v_b i_b + v_c i_c \tag{18}$$

By transforming ac side to the synchronous rotating reference frame, Eq. (19) is turned into Eq. (18)

$$V_R I_R = \frac{3}{2} (v_q^g i_q^g + v_d^g i_d^g) \tag{19}$$

Simultaneously using Eq. (12) and above equation results

$$V_R I_R = \frac{3}{2} (v_q^g i_q^g) \tag{20}$$

So, dc current is determined by substituting the Eq. (16) and Eq. (11) in Eq. (20)

$$I_R = \frac{\pi}{2\sqrt{3} \cos \alpha} i_q^g \tag{21}$$

In order to calculate the current in the d-axis, the term describing the power in ac side is written again.

$$S = P + jQ = \frac{3}{2} v_q^g (i_q^g + j i_d^g) \tag{22}$$

So, the reactive power is added to the both side of the equation.

$$Q = \frac{3}{2} (v_q^g i_q^g) = V_R I_R \sin \alpha \quad (23)$$

d-axis current is calculated by substituting Eq. (11), Eq. (16) and Eq. (21) in the Eq. (23)

$$i_d^g = i_q^g \tan \alpha \quad (24)$$

The equivalent circuit of dc-link which is the simplified one of the lead-acid model is composed of a capacitor and a series resistor with an ideal voltage source [14]. For the aim of creating a generator – rectifier equivalent circuit, all of the dc side parameters should be transformed to the rotor rotating reference frame. So, the following changes are applied.

$$V_R' = V_R \frac{\pi}{3\sqrt{3} \cos \alpha} \quad (25)$$

$$I_R' = I_R \frac{3\sqrt{3} \cos \alpha}{\pi} = i_q^g \quad (26)$$

$$E_R' = E_R \frac{\pi}{3\sqrt{3} \cos \alpha} \quad (27)$$

Where, E_b is the dc-link voltage. According to equation (25), since the ratio between the two voltages could be considered as the transformer ratio, the impedances could be transformed to ac side by square of the ratio between the two voltages. Therefore, resistance, inductance and capacitance of the dc side will be specified, in the ac side, with the values as following:

$$R' = R \frac{\pi^2}{18 \cos^2 \alpha} \quad (28)$$

$$L' = L \frac{\pi^2}{18 \cos^2 \alpha} \quad (29)$$

$$C' = C \frac{18 \cos^2 \alpha}{\pi^2} \quad (30)$$

Regarding the expression given above, the equivalent circuit of the wind energy conversion system is extracted as shown in Fig. 7.

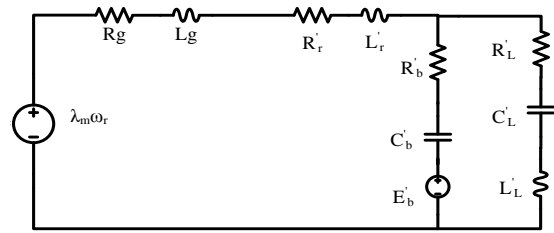

Fig. 7. Equivalent circuit of wind energy conversion system

4. Shunt active filter

As mentioned earlier, the shunt active filter is composed of three main parts namely identification, modulation and inverter. In the identification component, line parameters are sampled and the proper reference signals are generated. Next step is called the modulation which prepares the logic signals for driving the inverter transistors. Finally, the inverter generates a signal based on the reference signals produced in the identification step. It allows mitigating the current harmonics by injecting the generated signals into the line. The outline of this filter is shown in Fig. 8.

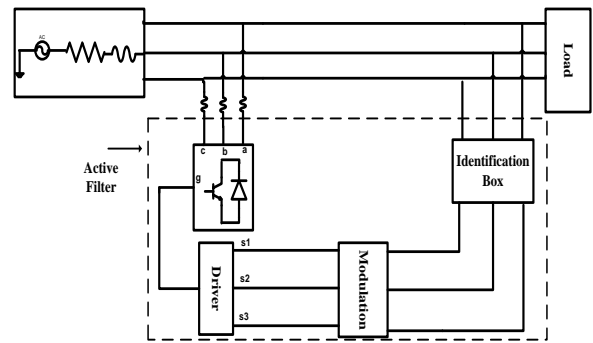

Fig.8. Diagram of shunt active filter

4.1. Identification Method

The methods introduced for reference signal generation are divided in two groups: time-domain and frequency-domain methods. The time-domain based approaches such as d-q transformation (synchronously rotating reference frame) and p-q transformation (theory of instantaneous active and reactive power) generally act with the three-phase measurements and transformations, while frequency based approaches are based on FFT. In comparison with the frequency domain, the time domain based methods are faster, but the frequency domain based methods have higher accuracy. In this theory, 3 phase voltages and currents are measured in the abs coordination and then they are transformed to the orthogonal frame ($\alpha\beta$) by applying Eq. (31) and Eq. (32).

$$\begin{bmatrix} v_\alpha \\ v_\beta \\ v_o \end{bmatrix} = \sqrt{\frac{2}{3}} \begin{bmatrix} 1 & -0.5 & -0.5 \\ 0 & \frac{-\sqrt{3}}{2} & \frac{\sqrt{3}}{2} \\ \frac{1}{\sqrt{2}} & \frac{1}{\sqrt{2}} & \frac{1}{\sqrt{2}} \end{bmatrix} \begin{bmatrix} v_a \\ v_b \\ v_c \end{bmatrix} \quad (31)$$

$$\begin{bmatrix} i_\alpha \\ i_\beta \\ i_o \end{bmatrix} = \sqrt{\frac{2}{3}} \begin{bmatrix} 1 & -0.5 & -0.5 \\ 0 & \frac{-\sqrt{3}}{2} & \frac{\sqrt{3}}{2} \\ \frac{1}{\sqrt{2}} & \frac{1}{\sqrt{2}} & \frac{1}{\sqrt{2}} \end{bmatrix} \begin{bmatrix} i_a \\ i_b \\ i_c \end{bmatrix} \quad (32)$$

Then active and reactive powers are calculated in the new frame using Eq. (33). These powers contain both dc and ac components. The power determined in order to reduce the harmonics of line current must be opposite of the ac component of the calculated power. Therefore, the reference currents for the aim of compensating can be obtained by Eq. (34). Finally, the currents resulted from Eq. (34) are returned to ABC coordination by the inverse transformation given as Eq. (35).

$$\begin{bmatrix} P \\ q \\ P_o \end{bmatrix} = \begin{bmatrix} v_\alpha & v_\beta & 0 \\ -v_\beta & v_\alpha & 0 \\ 0 & 0 & v_o \end{bmatrix} \begin{bmatrix} i_\alpha \\ i_\beta \\ i_o \end{bmatrix} \quad (33)$$

$$\begin{bmatrix} i_\alpha^* \\ i_\beta^* \\ i_o^* \end{bmatrix} = \begin{bmatrix} v_\alpha & v_\beta & 0 \\ -v_\beta & v_\alpha & 0 \\ 0 & 0 & v_o \end{bmatrix}^{-1} \begin{bmatrix} -P_{ac} \\ -q_{ac} \\ -P_{oac} \end{bmatrix} \quad (34)$$

$$\begin{bmatrix} i_a^* \\ i_b^* \\ i_c^* \end{bmatrix} = \left\{ \sqrt{\frac{2}{3}} \begin{bmatrix} 1 & -0.5 & -0.5 \\ 0 & \frac{-\sqrt{3}}{2} & \frac{\sqrt{3}}{2} \\ \frac{1}{\sqrt{2}} & \frac{1}{\sqrt{2}} & \frac{1}{\sqrt{2}} \end{bmatrix} \right\}^{-1} \begin{bmatrix} i_\alpha^* \\ i_\beta^* \\ i_o^* \end{bmatrix} \quad (35)$$

This approach is capable of providing the desired solution for the sinusoidal system. However, there is no proper result if the presence of the harmonic sources is considered. In order to prove this matter, we consider that the currents and voltages to be polluted according to Eq. (36) and Eq. (37).

$$\begin{cases} v_a = \sum_{n=1}^{\infty} \sqrt{2}V_n \sin(n\omega t + \psi_n) \\ v_b = \sum_{n=1}^{\infty} \sqrt{2}V_n \sin(n\omega t + 120 + \psi_n) \\ v_c = \sum_{n=1}^{\infty} \sqrt{2}V_n \sin(n\omega t - 120 + \psi_n) \end{cases} \quad (36)$$

$$\begin{cases} i_a = \sum_{n=1}^{\infty} \sqrt{2}I_n \sin(n\omega t - \phi_n) \\ i_b = \sum_{n=1}^{\infty} \sqrt{2}I_n \sin(n\omega t - \phi_n + 120) \\ i_c = \sum_{n=1}^{\infty} \sqrt{2}I_n \sin(n\omega t - \phi_n - 120) \end{cases} \quad (37)$$

Now, if voltages and currents are transformed to the orthogonal frame and also expressed based on the positive, negative and zero sequences, the followings will be resulted:

$$\begin{cases} v_\alpha = \sqrt{3} \sum_{n=1}^{\infty} V_n^+ \sin(n\omega t + \psi_n^+) + V_n^- \sin(n\omega t + \psi_n^-) \\ v_\beta = \sqrt{3} \sum_{n=1}^{\infty} -V_n^+ \cos(n\omega t + \psi_n^+) + V_n^- \cos(n\omega t + \psi_n^-) \\ v_o = \sqrt{6} \sum_{n=1}^{\infty} V_n^o \sin(n\omega t + \psi_n^o) \end{cases} \quad (38)$$

$$\begin{cases} i_\alpha = \sqrt{3} \sum_{n=1}^{\infty} (I_n^+ \sin(n\omega t - \phi_n^+) + I_n^- \sin(n\omega t - \phi_n^-)) \\ i_\beta = \sqrt{3} \sum_{n=1}^{\infty} (-I_n^+ \cos(n\omega t - \phi_n^+) + I_n^- \cos(n\omega t - \phi_n^-)) \\ i_o = \sqrt{3} \sum_{n=1}^{\infty} (I_n^o \sin(n\omega t - \phi_n^o)) \end{cases} \quad (39)$$

The powers in this new frame are calculated using Eq. (40).

$$\begin{cases} P = 3 \sum_{i=1}^{\infty} \sum_{j=1}^{\infty} \begin{bmatrix} V_j^+ I_i^+ \cos((i-j)\omega t + \phi_i^+ - \psi_j^+) \\ + V_j^- I_i^- \cos((i-j)\omega t + \phi_i^- - \psi_j^-) \\ - V_j^+ I_i^- \cos((i+j)\omega t + \phi_i^- + \psi_j^+) \\ - V_j^- I_i^+ \cos((i+j)\omega t + \phi_i^+ + \psi_j^-) \end{bmatrix} \\ q = 3 \sum_{i=1}^{\infty} \sum_{j=1}^{\infty} \begin{bmatrix} -V_j^+ I_i^+ \sin((i-j)\omega t + \phi_i^+ - \psi_j^+) \\ + V_j^- I_i^- \sin((i-j)\omega t + \phi_i^- - \psi_j^-) \\ + V_j^+ I_i^- \sin((i+j)\omega t + \phi_i^- + \psi_j^+) \\ - V_j^- I_i^+ \sin((i+j)\omega t + \phi_i^+ + \psi_j^-) \end{bmatrix} \\ P_o = 3 \sum_{i=1}^{\infty} \sum_{j=1}^{\infty} V_j^o I_j^o \begin{bmatrix} \cos((i-j)\omega t + \phi_i^o - \psi_j^o) \\ - \cos((i+j)\omega t + \phi_i^o + \psi_j^o) \end{bmatrix} \end{cases} \quad (40)$$

One can extract dc component from these equations as following:

$$\begin{cases} P_{dc} = 3 \sum_{n=1}^{\infty} V_n^+ I_n^+ \cos(\phi_n^+ - \psi_n^+) + V_n^- I_n^- \cos(\phi_n^- - \psi_n^-) \\ q_{dc} = 3 \sum_{n=1}^{\infty} -V_n^+ I_n^+ \sin(\phi_n^+ - \psi_n^+) + V_n^- I_n^- \sin(\phi_n^- - \psi_n^-) \\ P_{o,dc} = 3 \sum_{n=1}^{\infty} V_n^o I_n^o \cos(\phi_n^o - \psi_n^o) \end{cases} \quad (41)$$

It is clearly shown from Eq. (41) that in the transmission of the dc power from the source to the load, harmonics are also involved. So, it is not enough to mitigate the line harmonic by compensating ac powers. Therefore, the applicability of this theory in the presence of voltage harmonics is decreased.

4.2. Improved identification method

In order for the resulted currents to be capable of mitigating harmonic, it is suggested to consider the instantaneous active and reactive power as following [15].

$$p_l(t) = v_a(t) \times i_a(t) + v_b(t) \times i_b(t) + v_c(t) \times i_c(t) \quad (42)$$

$$q_l(t) = \begin{vmatrix} a & b & c \\ v_a(t) & v_b(t) & v_c(t) \\ i_a(t) & i_b(t) & i_c(t) \end{vmatrix} \quad (43)$$

It seems that the fundamental and harmonic components of the active power should be separated and harmonic contents be compensated by the filter. In addition, the total of the reactive power must be compensated in order to obtain the desired unity power factor. Hence, the rated power of the filter is determined by Eq. (44) and Eq. (45).

$$p_l(t) = p_s(t) + p_f(t) = p_{ll}(t) + p_{lh}(t) \rightarrow \begin{cases} p_s(t) = p_{ll}(t) \\ p_f(t) = p_{lh}(t) \end{cases} \quad (44)$$

$$\begin{cases} q_{fa}(t) = q_{la}(t) \\ q_{fb}(t) = q_{lb}(t) \\ q_{fc}(t) = q_{lc}(t) \end{cases} \quad (45)$$

Where, $p_l(t)$ and $p_s(t)$ are the instantaneous active powers of the load and source, respectively. $p_f(t)$ is the instantaneous active power of the shunt filter, $p_{ll}(t)$ is the fundamental component of the instantaneous active power, $p_{lh}(t)$ is instantaneous active power of harmonic components, $q_{fa}(t)$, $q_{fb}(t)$ and $q_{fc}(t)$ are the reactive powers produced by the a, b and c phases of the filter, respectively. Also, $q_{la}(t)$, $q_{lb}(t)$ and $q_{lc}(t)$ are the absorbed instantaneous active power by the nonlinear load. As shown in Fig. 1, the instantaneous reactive power and harmonic components of the active power

must be supplied by the shunt filter in order to generate only the fundamental active power from the power supply.

For the purpose of compensating the reactive power, we must have

$$\begin{bmatrix} q_{fa}(t) \\ q_{fb}(t) \\ q_{fc}(t) \end{bmatrix} = \begin{bmatrix} 0 & -v_c & v_b \\ v_c & 0 & -v_a \\ -v_b & v_a & 0 \end{bmatrix} \times \begin{bmatrix} i_{fa} \\ i_{fb} \\ i_{fc} \end{bmatrix} \quad (46)$$

And compensating the harmonic active power leads to expressing the following equation:

$$p_f(t) = v_a(t) \times i_{fa}(t) + v_b(t) \times i_{fb}(t) + v_c(t) \times i_{fc}(t) = p_{lh}(t) \quad (47)$$

In this case, In order to extract the reference currents by matrix addition of Eq. (46) and Eq. (47) we have

$$\begin{bmatrix} 0 & -v_c & v_b \\ v_c & 0 & -v_a \\ -v_b & v_a & 0 \end{bmatrix} \times \begin{bmatrix} i_{fa} \\ i_{fb} \\ i_{fc} \end{bmatrix} = \begin{bmatrix} q_{la}(t) + p_{lh}(t) \\ q_{lb}(t) \\ q_{lc}(t) \end{bmatrix} \quad (48)$$

Thereupon

$$\begin{bmatrix} i_{fa} \\ i_{fb} \\ i_{fc} \end{bmatrix} = \begin{bmatrix} 0 & -v_c & v_b \\ v_c & 0 & -v_a \\ -v_b & v_a & 0 \end{bmatrix}^{-1} \times \begin{bmatrix} q_{la}(t) + p_{lh}(t) \\ q_{lb}(t) \\ q_{lc}(t) \end{bmatrix} \quad (49)$$

The currents are calculated using Eq. (49) as following

$$\begin{aligned} i_{fa} &= \frac{1}{v_a^2 + v_b^2 + v_c^2} [(v_b^2 + v_c^2)i_{la} - v_a(v_b i_{lb} + v_c i_{lc}) + p_{lh} v_a] \\ i_{fb} &= \frac{1}{v_a^2 + v_b^2 + v_c^2} [(v_a^2 + v_c^2)i_{lb} - v_b(v_a i_{la} + v_c i_{lc}) + p_{lh} v_b] \\ i_{fc} &= \frac{1}{v_a^2 + v_b^2 + v_c^2} [(v_b^2 + v_a^2)i_{lc} - v_c(v_a i_{la} + v_b i_{lb}) + p_{lh} v_c] \end{aligned} \quad (50)$$

Following expression can be written based on the absorbed power from the load verified by Eq. (42)

$$\begin{aligned} p_l(t) - v_a(t) \times i_a(t) &= v_b(t) \times i_b(t) + v_c(t) \times i_c(t) \\ p_l(t) - v_b(t) \times i_b(t) &= v_a(t) \times i_a(t) + v_c(t) \times i_c(t) \\ p_l(t) - v_c(t) \times i_c(t) &= v_a(t) \times i_a(t) + v_b(t) \times i_b(t) \end{aligned} \quad (51)$$

Substituting Eq. (51) in Eq. (50) results in

$$\begin{aligned}
 i_{fa} &= i_{la} - \frac{P_l}{v_a^2 + v_b^2 + v_c^2} v_a + \frac{P_{lh}}{v_a^2 + v_b^2 + v_c^2} v_a \\
 i_{fb} &= i_{lb} - \frac{P_l}{v_a^2 + v_b^2 + v_c^2} v_b + \frac{P_{lh}}{v_a^2 + v_b^2 + v_c^2} v_b \\
 i_{fc} &= i_{lc} - \frac{P_l}{v_a^2 + v_b^2 + v_c^2} v_c + \frac{P_{lh}}{v_a^2 + v_b^2 + v_c^2} v_c
 \end{aligned} \tag{52}$$

It can be concluded from Eq. (52) that the active component of the load current should be supplied by the source and harmonic contents and the reactive component of the load current should be provided by the compensator. If the filter needs only to provide the reactive power compensation, then the third term of Eq. (52) must be omitted. Similarly, if the filter is only required to compensate the load harmonic power, the second term of Eq. (55) must be eliminated in this case. In any cases, harmonic power and reactive power components of the load current will be compensated through injecting the currents determined in Eq. (52) to the grid by the filter. The expressions described in Eq. (52) may be written as follow for simplification:

$$\begin{aligned}
 i_{fa} &= i_{la} - \frac{P_{l1}}{v_a^2 + v_b^2 + v_c^2} v_a \\
 i_{fb} &= i_{lb} - \frac{P_{l1}}{v_a^2 + v_b^2 + v_c^2} v_b \\
 i_{fc} &= i_{lc} - \frac{P_{l1}}{v_a^2 + v_b^2 + v_c^2} v_c
 \end{aligned} \tag{53}$$

As previously mentioned, p_{l1} is the fundamental power related to the load current.

5. Simulation results

A system is shown in Fig. 5 while its are presented parameters in Table 1. High and low order harmonics exist in the output current of the PMGS with simulation of system in PSIM software, as shown in Fig. 9. The compensation performance of the proposed active filter is tested on this system in order to reduce its harmonics.

5.1. Uncompensated system

Provided that this test system is simulated based on parameters given in Table 1, the output current of PMSG is as shown in Fig. 10. This current contains 13.92 % of the harmonic and hence, it is necessary to reduce its harmonics according to the IEEE-519 standard.

5.2. Compensated system

The current harmonic distortion level has been reduced to an acceptable value i.e 2.3 % as shown in Fig. 11, by applying the proposed filter and the compensation method.

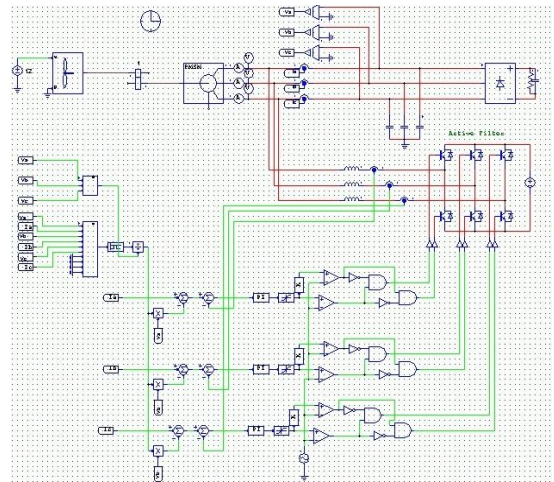

Fig. 9. The detailed model of system in PSIM software

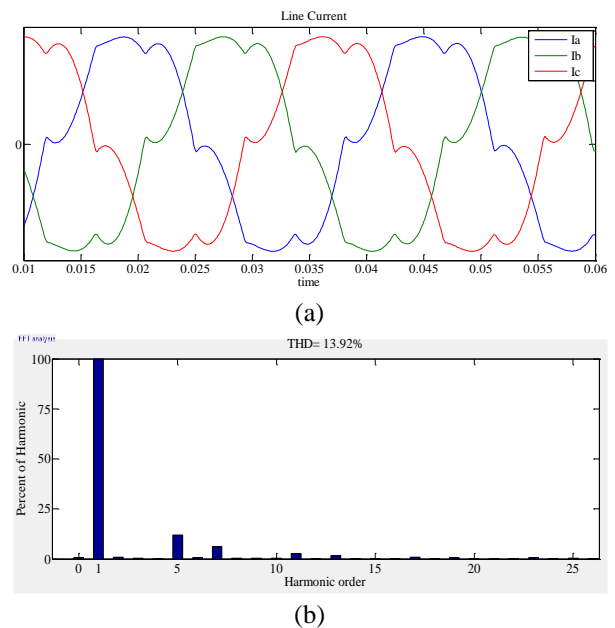

Fig. 10. The current without active filter: a) Time waveform b) frequency spectrum

5.3. Subsidiary advantage

As it can be observed in Figures 12 and 13, the voltage harmonic has been dropped from 29.48 % to 22.78 %. Although the aim of using the shunt filter is not to reduce the voltage harmonics, designed filter is capable of reducing them. Indeed, the filter is unable to satisfy the standard related to the voltage harmonics, but the mitigation of this harmonic can be considered as a subsidiary (not the main) advantage.

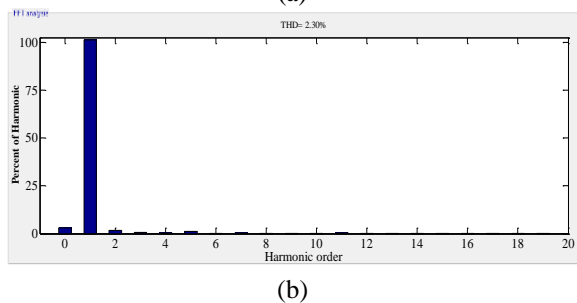
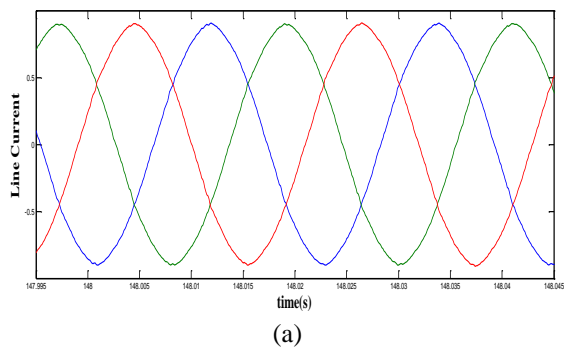

Fig. 11. The current with active filter: a) Time waveform b) frequency spectrum

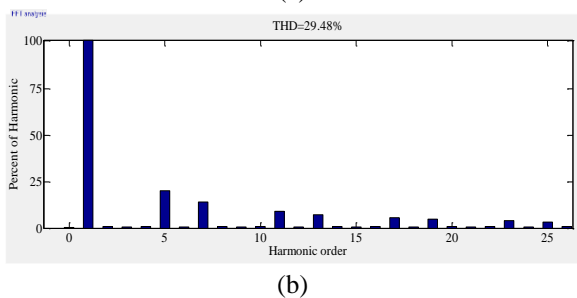
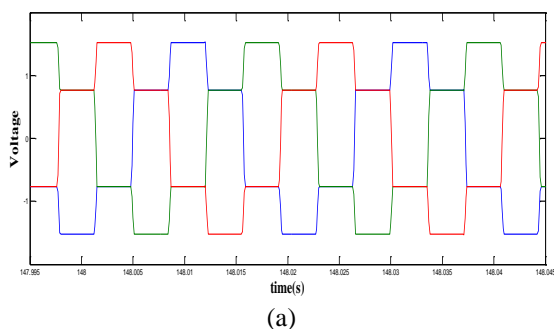

Fig. 12. The voltage without compensator: a) Time waveform b) frequency spectrum

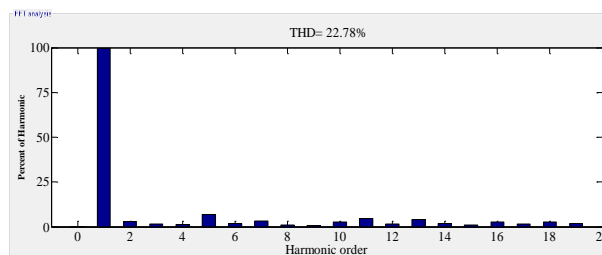
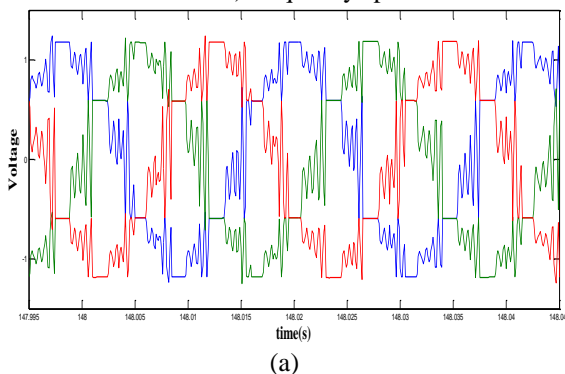

Fig. 13. The voltage with compensator: a) Time waveform b) frequency spectrum

Table 1. Parameters of wind turbine, converter system and load

Parameter	Description	Value
P_t	Rated Power of Turbine	20kw
V_m	Wind Speed	12m/s
J_t	Inertia of the turbine	1500
R_s	Stator's Resistance	0.432Ω
L_d	Inductance in d-axis	5.24mH
L_q	Inductance in q-axis	5.24mH
J_m	Inertia of the machine	1.954
C_L	Load Capacitance	5000 μ F
R_L	Load Resistance	6.5 Ω
C_F	Filter Capacitance	3.9 μ F

6. Conclusion

In this paper, a shunt active filter was proposed to reduce the current harmonics of the wind turbines. The method used in the identification box of the filter was designed regarding the system harmonics. This compensator is capable of not only reducing the voltage harmonics but also mitigating the current disturbance.

References

- [1] American Wind Energy Association website. Available: www.awea.org
- [2] G. W. E. Council, "Global wind power continues expansion," Retrieved June, vol. 24, p. 2005, 2005.
- [3] E. Allan, N. Jenkins, F. Castro, Z. Saad-Saoud, J. Roman, M. Rodrifues, et al., "Large wind turbines and weak rural electricity systems," in Proceedings of the BWEA Conference, Stirling, 1994.
- [4] F. S. dos Reis, S. Islam, K. Tan, J. Ale, F. Adegas, and R. Tonkoski, "Harmonic mitigation in wind turbine energy conversion systems," in Power Electronics Specialists Conference, 2006. PESC'06. 37th IEEE, 2006, pp. 1-7.
- [5] J. Li, N. Samaan, and S. Williams, "Modeling of large wind farm systems for dynamic and harmonics analysis," in Transmission and Distribution Conference and Exposition, 2008. T&D 2008. IEEE/PES, 2008, pp. 1-7.
- [6] F. S. dos Reis, J. Ale, F. Adegas, R. Tonkoski, S. Slan, and K. Tan, "Active shunt filter for harmonic mitigation in wind turbines generators," in Power Electronics Specialists Conference, 2006. PESC'06. 37th IEEE, 2006, pp. 1-6.
- [7] V. F. Corasaniti, M. B. Barbieri, P. L. Arnera, and M. I. Valla, "Hybrid active filter for reactive and harmonics compensation in a distribution network," *Industrial Electronics, IEEE Transactions on*, vol. 56, pp. 670-677, 2009.
- [8] A. Hoseinpour and R. Ghazi, "Harmonic Reduction in Wind Turbine Generators Using a Shunt Active Filter," *International Review on Modelling & Simulations*, vol. 5, 2012.
- [9] S. Rahmani, N. Mendalek, and K. Al-Haddad, "Experimental design of a nonlinear control technique for three-phase shunt active power filter," *Industrial Electronics, IEEE Transactions on*, vol. 57, pp. 3364-3375, 2010.
- [10] A. Hoseinpour, S. M. Barakati, and R. Ghazi, "Harmonic reduction in wind turbine generators using a Shunt Active Filter based on the proposed modulation technique," *International Journal of Electrical Power & Energy Systems*, vol. 43, pp. 1401-1412, 2012.
- [11] B. S. Borowy and Z. M. Salameh, "Dynamic response of a stand-alone wind energy conversion system with battery energy storage to a wind gust," *Energy Conversion, IEEE Transactions on*, vol. 12, pp. 73-78, 1997.
- [12] B. Sedaghat, A. Jalilvand, and R. Noroozian, "Design of a multilevel control strategy for integration of stand-alone wind/diesel system," *International Journal of Electrical Power & Energy Systems*, vol. 35, pp. 123-137, 2012.
- [13] P. C. Krause, "Analysis of Electric Machinery. 1986," ed: McGraw-Hill, New York.
- [14] W. Lynch, "Ni-Cd Battery Modeling, Evaluation and Applications in Electric Car," Doctoral Dissortation, University of Massachusetts Lowell, Lowell, MA, anticipated date of publication-June, 1996.
- [15] D. N. M. Teimouri, S. H. Hoseini, "New Method for Calculation of Reference Currents of ALPC for Reactive Power Control, Harmonics Elimination and Load Balancing in Unbalanced Conditions," presented at the 18 Conference of Electrical Engineering, Iran, 2003.