

Optimal Power Flow Management Control for Grid Connected Photovoltaic/Wind turbine/Diesel generator (GCPWD) Hybrid System with Batteries

Balamurugan.T^{*‡}, Manoharan.S^{**}

^{*}Department of Electrical & Electronics of Engineering, Karpagam University, India

^{**} Department of Electronics & Instrumentation Engineering, Karpagam College of Engineering, India

(balaeec.mtech@gmail.com, balathamizhan.be@gmail.com)

[‡]Corresponding Author; Balamurugan.T; Dr.Manoharan.S, Karpagam University, Coimbatore, Tamilnadu, India,
Tel: +91-98439 43308, balaeec.mtech@gmail.com

Received: 14.09.2013 Accepted: 16.10.2013

Abstract- This paper proposes a Optimal Power Flow Management control for Grid Connected Photovoltaic/Wind turbine/Diesel generator (GCPWD) Hybrid System with hybrid storage system. The energy system having a photo voltaic (PV) panel, wind turbine (WT) and diesel generator (DG) for continuous power flow management. A diesel generator is added to ensure uninterrupted power supply due to the discontinuous nature of solar and wind resources. The developed Grid Connected Photovoltaic/Wind turbine/ Diesel generator (GCPWD) Hybrid System has been applied to supply continuous power to the AC/DC loads. A Grid Connected Photovoltaic/Wind turbine/ Diesel generator (GCPWD) hybrid systems three power sources (PV, wind turbine and diesel generator) and two power sink (AC&DC loads). In this paper, the power flow management algorithm has five modes of operation namely, the PV mode, wind turbine mode, battery bank mode, hybrid mode and diesel generator mode. A prototype for the proposed system was designed, implemented and tested using a controlled load result show a DC linked/AC linked hybrid PV/Wind Turbine/diesel generator energy sources for standalone applications. The conventional boost converter decreases the efficiency of the system during turn On/Off during this interval, all switches in the proposed work perform zero-current switching (ZCS) by resonant inductor at turn-on and zero-voltage switching (ZVS) by resonant capacitor at turn-off. This switching pattern can reduce the switching losses and increases the efficiency of energy conversion of energy sources experimental results show that the hybrid energy system can deliver energy in a standalone installation with an acceptable cost.

Keywords PhotoVoltaic (PV) system, WindTurbine (WT) system, Diesel Generator (DG), Grid, Batteries.

1. Introduction

Now-a-days increasing the energy consumption has become a primary concern, the soaring cost and the exhaustible nature of fossil fuel, and the worsening global interest in renewable energy sources increase of fossil fuel resources and the need of reducing CO₂ emissions, grid connected renewable power systems have gained outstanding interest[1]. Energy is considered as an important mechanism in a country for the development, but in the current situation, the energy consumption is insufficient and the price is increasing [2]. PV cells convert the energy from sunlight into DC electricity wind turbine convert the energy from wind

into electricity. PV and wind turbine offer added advantages over other renewable energy sources in that they give off little noise and require practically little maintenance [5]. Hybridizing solar and wind power sources provide a realistic form of power generation. The electricity grid to accommodate higher percentage of renewable energy would need large quantities of conventional back up power and huge energy storage. These would be necessary to compensate for natural variations in the amount of power generated depending on the time of day, season and other factors such as the amount of sunlight (or)wind at any given time [6].

In this paper proposes, the power flow management for Grid Connected Photovoltaic/Wind turbine/ Diesel generator (GCPWD) with the forces on optimal scheduling. This hybrid system include PV panels wind turbine, diesel generator and battery bank etc. wind and solar power are the two most widely used renewable sources of energy among all renewable sources solar panels and windturbine are the main energy sources and the Battery Bank are the backup energy source for the system. The Hybrid system will focus to use of solar energy and wind energy as a Hybrid source, the Hybrid source has to be enough to support the AC loads and DC loads. If the energy is not enough, the system will start the Battery bank (or) the diesel generators automatically. In

Fig.1 shows, Grid Connected Photovoltaic/Wind turbine/ Diesel generator (GCPWD) Hybrid system. It comprises of Photovoltaic panel, Wind turbine, Diesel generator and Battery bank. Grid Connected Photovoltaic/Wind turbine/Diesel generator (GCPWD)Hybrid System technology is the key for an efficient use of distributed energy sources. PV and wind turbine are being major energy source enables the dc loads and AC loads to be connected directly to the DC bus and grid. In the hybrid generator system, they are integrated and complement with each other in order to meet performance targets of the generation system and access to the most economic power generation.

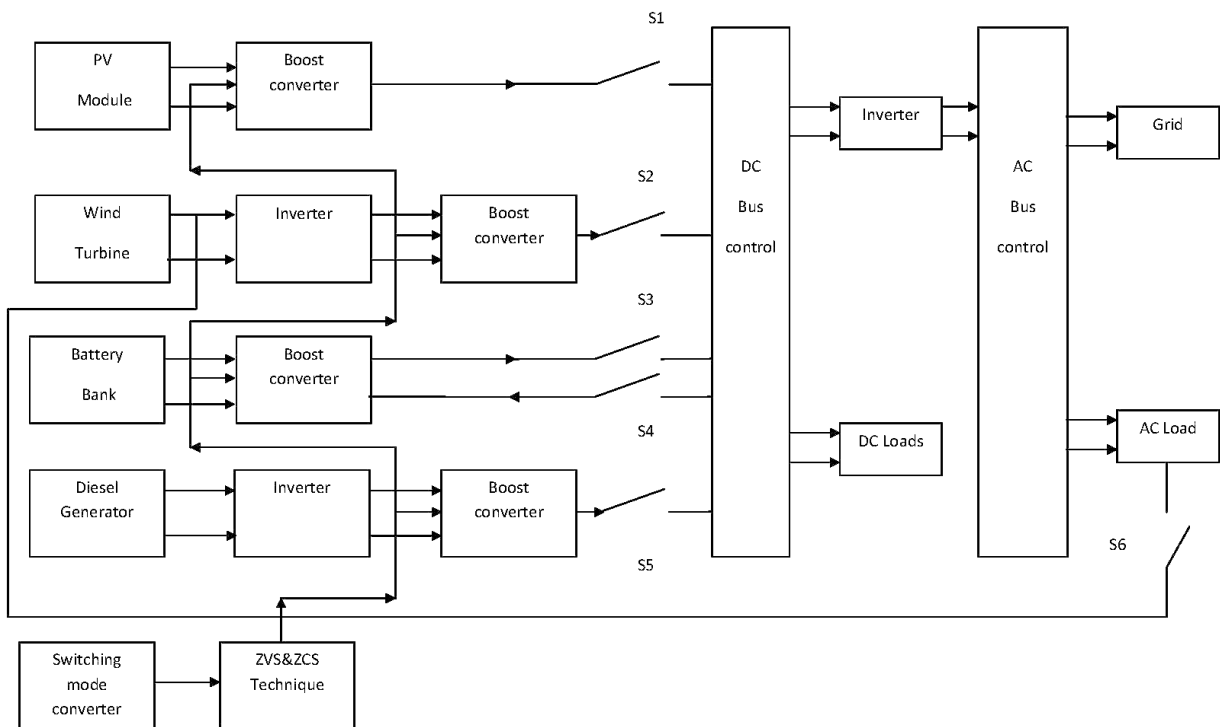

Fig. 1. Grid Connected Photovoltaic/Wind turbine/Diesel generator (GCPWD) Hybrid System

This paper deals with power flow management for Grid Connected Photovoltaic/Wind turbine/Diesel generator (GCPWD) hybrid system with an optimal control. Section II presents the system configuration and analyses of different modes of operation. Section III presents the Grid Connected Photovoltaic/Wind turbine/Diesel generator system. Sections IV are represented Modeling of Power flow management for Grid connected PV/Wind Turbine/Diesel Generator (GCPWD) hybrid system. Section V presents the Experimental result analysis of Grid connected Photovoltaic/Wind turbine/Diesel generator (GCPWD) hybrid system and Section VI are concludes the Grid Connected Photovoltaic/Wind turbine/Diesel generator(GCPWD) hybrid system

2. System Configuration and Overview

In this paper, a new power management topology for hybridizing the solar energy sources, wind energy sources, battery and diesel generator sources has been proposed. In this topology, solar and wind turbine energy source are incorporated together using a combination of boost converters using a combination of *boost* converter, so that if are of them is unavailable, then the other source can compensate for it. In Table 1 represents different modes of operation of Grid Connected Photovoltaic/Wind turbine/Diesel generator(GCPWD) hybrid system.

Table 1 Different Modes of Operation- GCPWD

MODE NO	State of switching device						MODE NAME	STORAGE DEVICE
	S1	S2	S3	S4	S5	S6		
Mode-I	ON	OFF	ON	OFF	OFF	OFF	PV MODE	BATTERY BANK
Mode-II	OFF	ON	ON	OFF	OFF	OFF	WT MODE	BATTERY BANK& GRID
Mode-III	OFF	OFF	OFF	ON	OFF	OFF	BATTERY BANK	BATTERY BANK
Mode-IV	OFF	OFF	OFF	ON	ON	OFF	DIESEL GENERATOR	BATTERY BANK& GRID
Mode-V	ON	ON	OFF	ON	OFF	OFF	HYBRID MODE	BATTERY BANK& GRID

In Fig 2 shows, the Mode-I operation of the Grid Connected Photovoltaic/Wind turbine/Diesel generator (GCPWD). In this PV mode, DC load are drive with the help of DC bus and during this mode battery are charged.

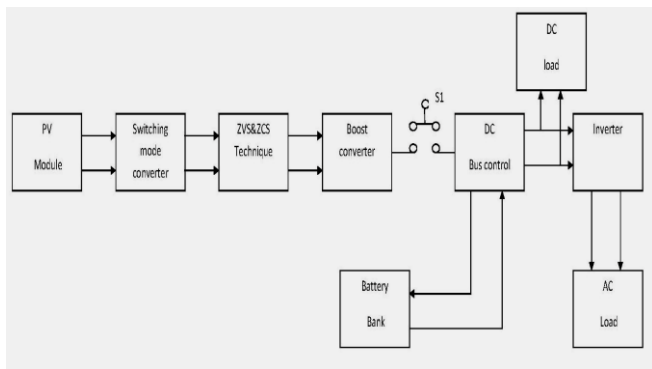

Fig. 2. Mode –I operation – PV Mode

In Fig 3 shows, the Mode- II operation of the Grid Connected Photovoltaic/Wind turbine/Diesel generator (GCPWD). In this Wind turbine mode, DC loads and AC loads are drive with the help of DC bus and Grid.

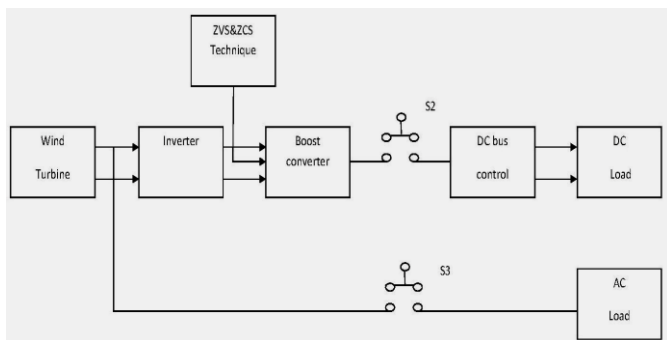

Fig. 3. Mode –II operation – WT Mode

In Fig 4 shows, the Mode-III operation of Grid Connected Photovoltaic/Wind turbine/Diesel generator

(GCPWD).In this battery mode, batteries are charged during the mode-I and mode-II. Battery are discharged, If the energy is not enough the system will start automatically.

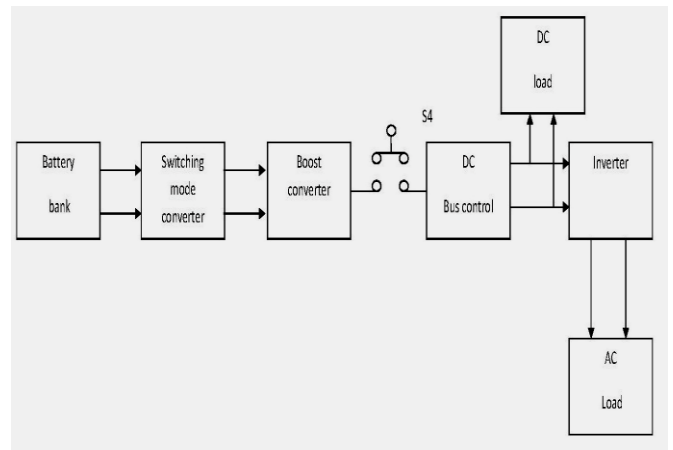

Fig 4 Mode –III operation – BATTERY Mode

In Fig.5 shows, the mode- IV operation of Grid Connected Photovoltaic/Wind turbine/Diesel generator (GCPWD). In this Diesel generator mode are turned ON, If the energy is not enough, the Diesel generator will start automatically.

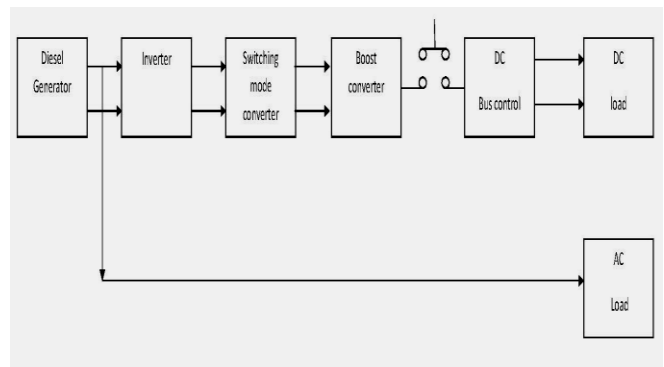

Fig 5. Mode –IV operation-Diesel generator Mode

In Fig 6 shows, the Mode- V operation of Grid Connected Photovoltaic/Wind turbine/Diesel generator (GCPWD) .In this hybrid mode, PV and Wind turbine (S1 & S2) are turned ON, and to drive the DC load and AC loads.

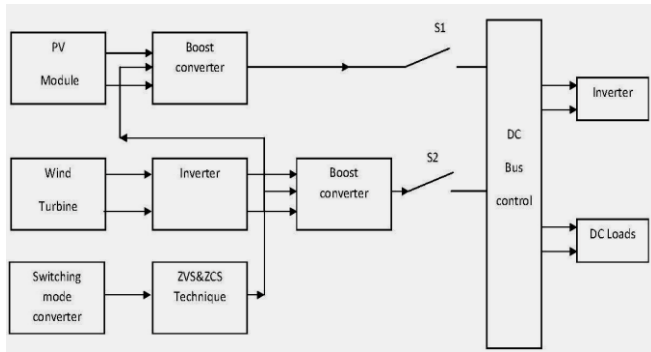

Fig 6. Mode-V operation –Hybrid mode

3. Grid Connected Photovoltaic/Wind turbine/Diesel generator (GCPWD) Hybrid System

3.1. PV Generation System

A Photovoltaic cell can be represented by a current source connected in parallel with a diode [7].The equivalent circuit model also includes a shunt resistance (Rsh) and series resistance (Rs). The PV sizing variable comprises of size of a PV Panel and the number of strings in a PV array [18]. The necessary number of PV panels to be connected in the series is derived by the number of Panels need to match the bus operating voltage.The output of PV panels must include the input of geographic location such as irradiation and temperature etc. Fig.7 shows the equivalent circuit of Photovoltaic panel. The output current and output power of Photovoltaic panels at any time ‘t’ can be calculated as:

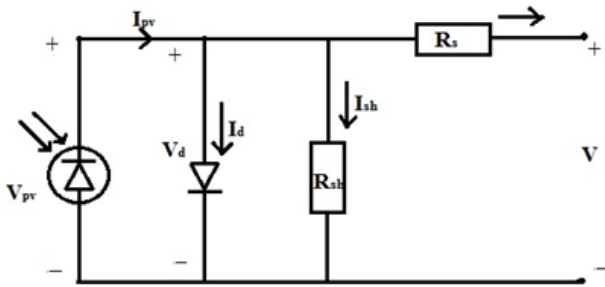

Fig 7:Equivalent circuit of PV Panel

$$I = I_{pv,cell} - I_d = I_{pv,cell} - I[\exp(qv/\infty KT) - 1] \tag{1}$$

$$I = I[\exp(V_d/V_T) - 1] \tag{2}$$

$$V = V_d - R_s I_{PV} \tag{3}$$

$$PPV = \eta_{PV} * (N_{PV})^p * (N_{PV})^s * (V_{PV}) * I_{PV} \tag{4}$$

Where,

I_{PV} is operating current of PV panels.

V_{PV} is operating voltage of PV panels.
 η_{PV} is conversion efficiency of PV panels.
 $(N_{PV})^p$ is the number of PV panel in parallel.
 $(N_{PV})^s$ is the number of PV Panel in series.
 PPV is the output power.

3.2. Wind Turbine System

Wind turbine system the power from the wind by means of aerodynamically designed blades and convert it to rotating mechanical power [8].The energy and current of the wind turbine Generator for each instant are depend on local weather conditions and actual installation weight of the wind turbines. Wind turbines are usually connected in parallel,not in a series. The equivalent circuit of wind turbine are represented as shown in Fig.8.

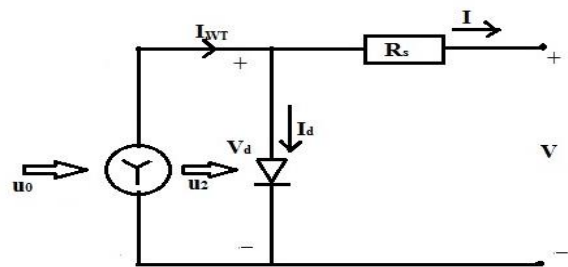

Fig. 8. Equivalent circuit of wind turbine

$$P_w = 1/2[m(u_0 - u_2)] \tag{5}$$

$$P_o = 1/2[\rho A u_0^3] \tag{6}$$

$$P(t) = \eta_w * \eta_g * 0.5 * \rho_a * C_P * A * V_r^2 \tag{7}$$

Where,

- P_w is the output power in watts
- P_a is the extracted output from wind in watts
- P_{wt} is the generated output power in watts
- η_w is the efficiency of wind turbine.
- η_g is the efficiency of generator.
- ρ_a is the density of air.
- C_P is the power co-efficient of wind turbine.
- A is the wind turbine swept area.

3.3. Storage Batteries

The batteries are used to store the excess energy during the low generation period. The equivalent circuit batteries are represented as shown the Fig.9.

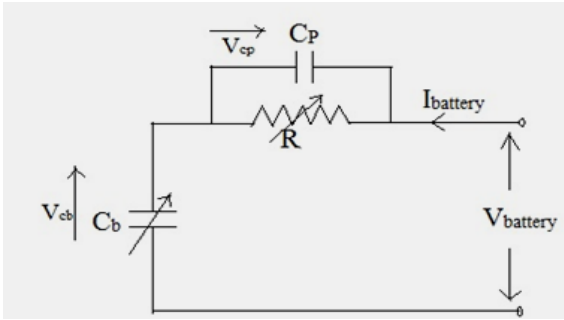

Fig. 9. Equivalent circuit of battery

The power input to the battery bank is calculated as

$$P_{battery} = P_{PV} + P_{WT} - P_{load} \quad (8)$$

$$P_{total} = \sum_{w=1}^{W_n} P_{WT} + \sum_{PV=1}^{S_n} P_{PV} \quad (9)$$

Where W_n, S_n are the total number of wind turbine generators and Photovoltaic respectively.

4. Modeling of Power Flow Management for Grid Connected Pv/Wind Turbine/Diesel Generator (GCPWD) Hybrid System

4.1. Modeling of Pv Array

Modeling of PV array has been designed by considering the irradiance, temperature and number of PV cells connected in series and parallel. PV array output is the input to the Boost converter [16]. Fig.10 shows the simulink model of PV array. Fig.11 shows the maximum power point tracking simulink model of PV array.

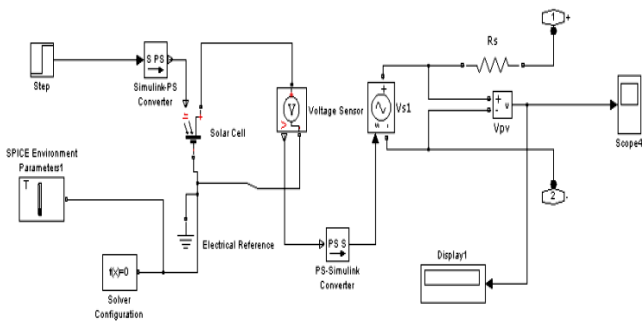

Fig. 10. Simulation of PV panel

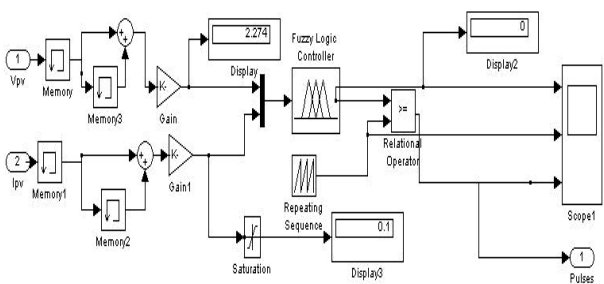

Fig. 11. MPPT for PV panel

Fig 12 shows the simulation parameters for the PV array. PV Models of reduced complexity can be specified in the mask. The quality factor varies for amorphous cells, and typically has a value in the range of 1 to 2. The physical signal input I_r is the irradiance (light intensity) in W/m^2 falling on the cell. The solar-generated current I_{ph} is given by $I_r \cdot (I_{ph0}/I_{r0})$ where I_{ph0} is the measured solar-generated current for irradiance I_{r0} .

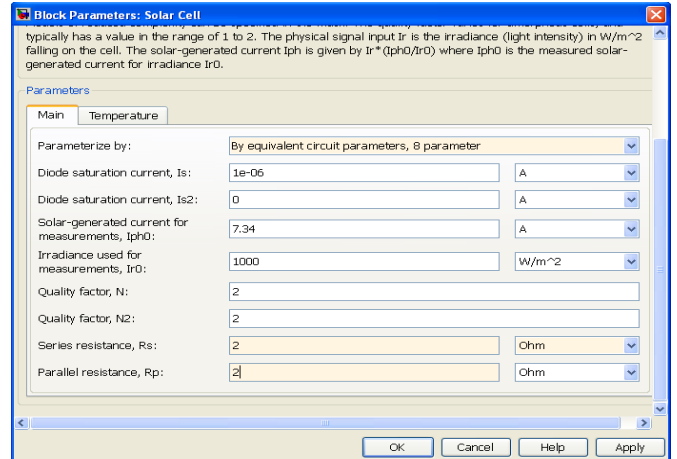

Fig. 12. Simulation Parameters for PV panel

4.2. Modeling of Wind Turbine

Modeling of Wind Turbine has been designed by considering the wind speed (m/s), pitch angle and generator speed. Wind Turbine output is the input to the Boost converter. Fig.13 shows the simulink model of Wind Turbine and also depends upon the rotor speed and electro magnetic torque values. Fig.14 shows the simulation output of wind turbine.

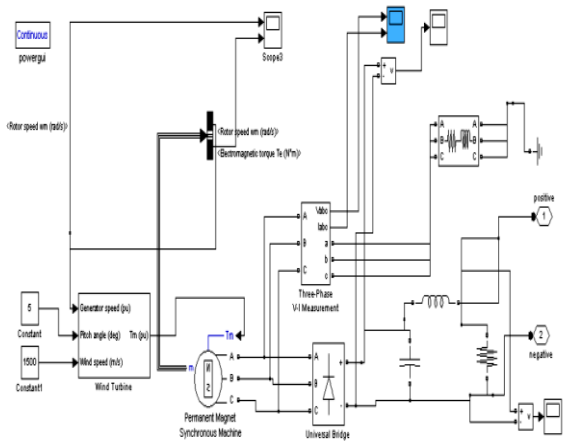

Fig. 13. Simulation of Wind Turbine

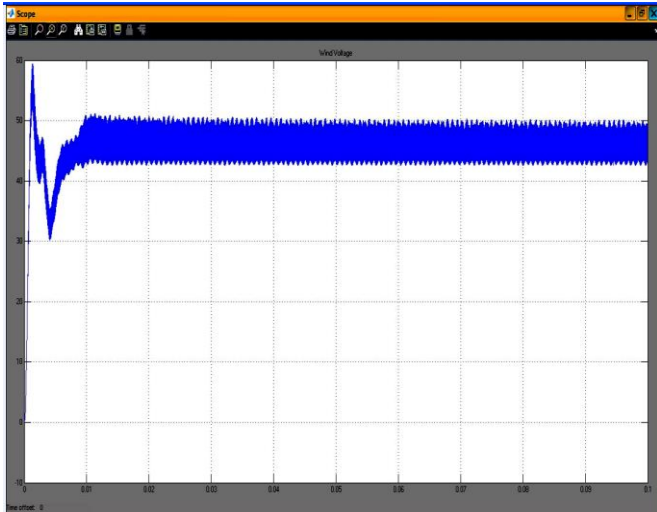

Fig. 14.Simulation output of Wind Turbine

Fig.15 shows the turbine power characteristics of wind turbine and the characteristics drawn between the turbine output power and turbine speed. Fig.16 shows simulation parameters and this block implements a variable pitch wind turbine model. The performance coefficient C_p of the turbine is the mechanical output power of the turbine divided by wind power and a function of wind speed, rotational speed, and pitch angle (β). C_p reaches its maximum value at zero β . Select the wind-turbine power characteristics display to plot the turbine characteristics at the specified pitch angle. The first input is the generator speed in per unit of the generator base speed. For a synchronous or asynchronous generator, the base speed is the synchronous speed. For a permanent-magnet generator, the base speed is defined as the speed producing nominal voltage at no load. The second input is the blade pitch angle (β) in degrees. The third input is the wind speed in m/s. The output is the torque applied to the generator shaft in per unit of the generator ratings.

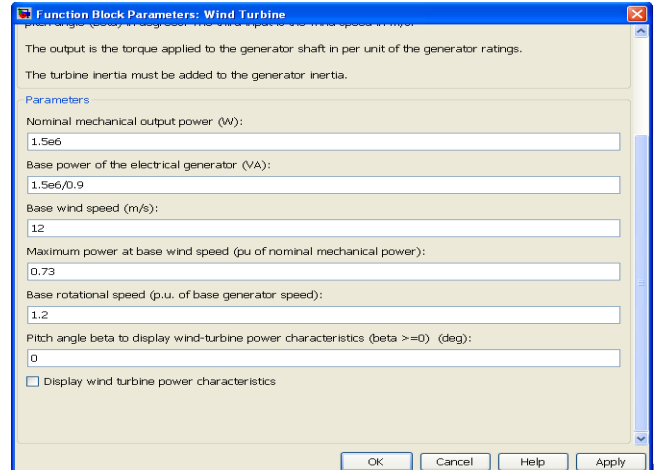

Fig. 16.Simulation parameters of Wind Turbine

4.3. Modeling of Grid Connected Pv/Windturbine/ Diesel Generator (GCPWD)

Modeling of grid connected hybrid system has been designed by considering the Photovoltaic, Wind Turbine, Diesel generator and battery bank. Modeling of PV array has been designed by considering the irradiance, temperature and number of PV cells connected in series and parallel. Modeling of Wind Turbine has been designed by considering the wind speed (m/s), pitch angle and generator speed. Fig.17 shows the Grid Connected PV/Wind turbine/Diesel generator (GCPWD) simulink model and fig. 18 shows the Grid Connected PV/Wind turbine/Diesel generator (GCPWD) simulink model output voltage and output current.

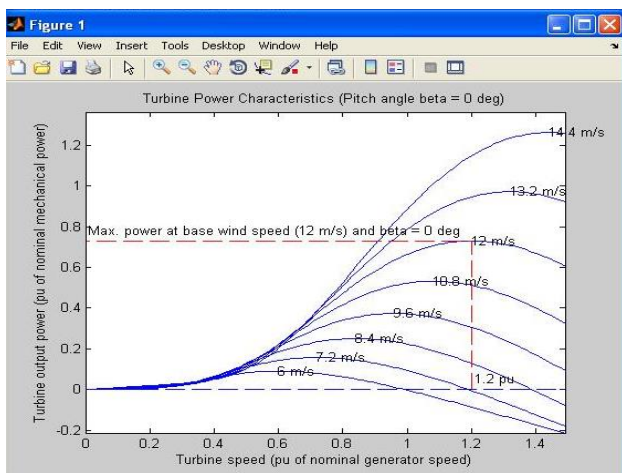

Fig. 15. Turbine Power characteristics of Wind Turbine

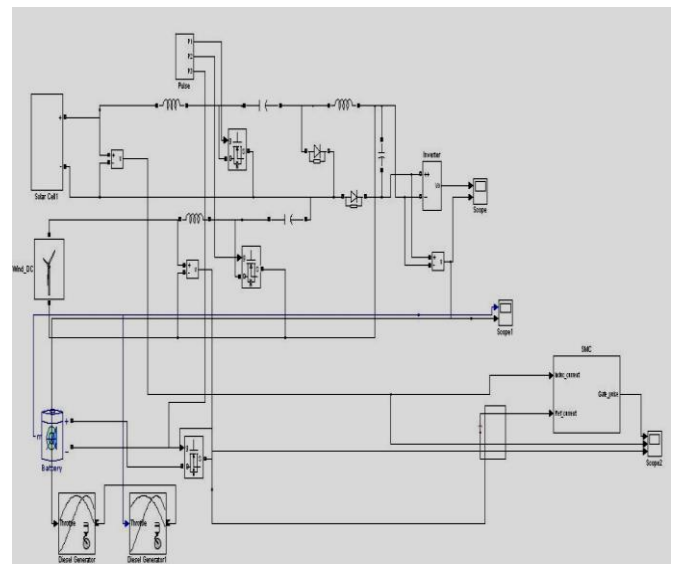

Fig. 17. GCPWD simulation circuit

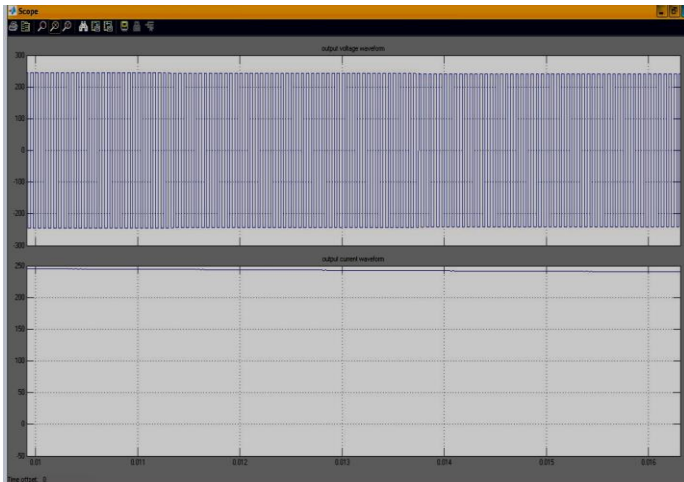

Fig. 18. GCPWD simulated result

Table 2. shows the simulation parameters of Grid Connected PV/Wind turbine/Diesel generator (GCPWD).

Table 2. Simulation Parameters

S.No	Parameters	Value
1.	Input voltage (Solar Panel)	70 V
2.	Input voltage (Wind Turbine)	60 V
3.	Output voltage (Boost converter)	230V
4.	Nominal mechanical power	1.5 e 6
5.	Base Wind Speed	12 m/s
6.	Maximum power at base wind speed	0.73 p.u
7.	Base rotational speed	1.2 p.u
8.	Solar irradiance	1000 w/m ²
9.	Output Voltage (GCPWD)	230 V

5. Hardware Setup of Gcpwd

Hardware implementation of proposed Grid Connected Photovoltaic/Wind turbine/ Diesel generator (GCPWD) hybrid system technology are represented as shown in Fig.19(A , B& C). In this paper, Grid Connected hybrid system include PV panels, wind turbine, diesel generator and battery bank etc. solar panels and windturbine are the main energy sources and the Battery Bank are the backup energy source for the system. If the energy is not enough, the system will start the Battery bank (or) the diesel generators automatically. Solar power generation and Wind power generation are the independent power generation can effectively solve the problem without electricity in the power demand conditions. The power flow management algorithm has three modes of operation namely, the PV mode, wind turbine mode and diesel generator mode. A prototype and tested using a controlled load result show a DC linked/AC linked

hybrid PV/Wind Turbine/diesel generator energy sources for standalone applications.

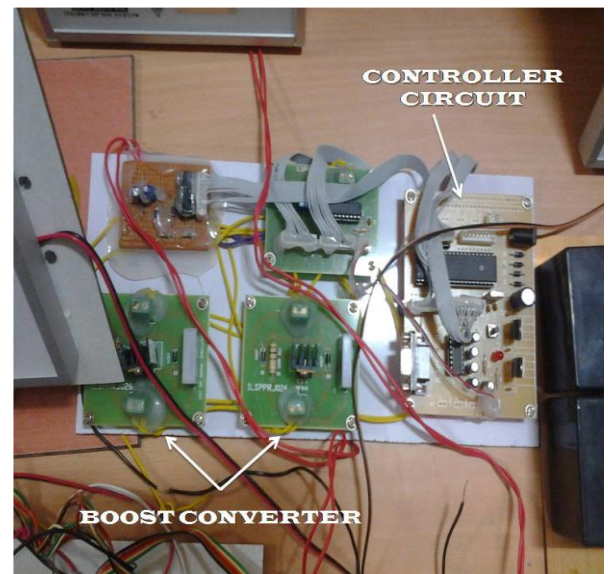

Fig. 19. (A , B& C)Experimental Setup of GCPWD

6. Conclusion

Hybrid systems are the right solution for a clean energy production and hybridizing solar and wind power sources provide a realistic form of power generation. In this proposed system, Grid Connected Photovoltaic/Wind turbine/Diesel generator (GCPWD) hybrid system can be used to supply

continuous power to the AC/DC loads. Zero voltage and Zero current switching pattern can reduce the switching losses and increases the efficiency of energy conversion of energy sources. Solar panels and wind turbine are the Main energy sources of the proposed grid connected system. Battery bank and Diesel generator are the Back up and auxiliary energy sources of the proposed grid connected system. Solar power generation and Wind power generation are the independent power generation can effectively solve the problem without electricity in the power demand conditions. The power management developed helps integration of PV power and Wind power in to the grid as peak loads are shaved. Depending of the reactive management in real condition, the power fluctuation of PV and wind turbine production is balanced to the power exchanged with the grid or with the batteries. Simulation results show the operation in real time operation in simulated real conditions has been performed and results are compared. In simulation over 24 hours, predictive optimization provides 15% of gain on the electricity bill for the economic context of the paper. MATLAB/Simulink software is used to model the PV panel, Wind Turbine, Battery bank, DC-DC converter, Inverter and Diesel generator. The power management of Grid connected PV/Wind turbine/Diesel generator (GCPWD) hybrid system technology was improved and verified by the simulation and experimental results.

References

- [1] Yann Riffonneau, Seddik bacha, Franck barruel and Stephanie Plane, "optimal power flow management for Grid connected PV system with Batteries"IEEE Transactions on sustainable energy, vor, no.3, PP.309-320, july 2011.
- [2] Rajesh Kumar, R.A.Gupta and Ajay Kumar Bansal,"Economic analysis and a Power Management of a stand-alone wind/Photovoltaic hybrid energy system using biogeography based optimization algorithm", smarm and evolutionary computation, Elsevier,PP33-43,2013
- [3] Trends in photo voltaic Applications survey Report of selected IEA countries between 1992 and 2007 IEA photo voltaic power systems program, IEA PVPS TI – 17, 2008.
- [4] Cristiana Dragos Dumitra , Adrian Gligor," SCADA based software for renewable energy management System, Elsevier, 262-267, 2012.
- [5] Shu – Hung et al., " A novel maximum Power point tracking Technique for solar panels using a SEPIC or Cuk Converters IEEE transaction on power electronic ,vol 18 [3], may 2003.
- [6] Kohsris,Plang klang B."energy management and control system for smart renewable energy remote power generation", Energy procedia2011,9:198-206.
- [7] P.Denhoma and R.M.Margolis,"evaluation the limits of solar Photovoltaics (PV) in electric power systems" Energy policy, Vol.35 PP.2852-2861,2007.
- [8] C.Wang and M.H.Nehir,"Power Management of a Stand-alone wind/Photovoltaic/fuel cell energy system",IEEE trans.Energy.Convers,Vol 23,no 3, PP-957-967,sep.2004
- [9] T. T. Ha Pham, F. Wurtz, and S. Bacha, "Optimal operation of a PV based multi-source system and energy management for household application," in Proc. IEEE Int. Conf. Industrial Technology (ICIT), Gippsland, Victoria, Australia, 2009, pp. 1–5.
- [10] B. Lu andM. Shahidehpour, "Short term scheduling of battery in a grid connected PV/battery system," IEEE Trans. Power Syst., vol. 20, no. 2, pp. 1053–1061, May 2005.
- [11] F. Besnard and L. Bertling, "An approach for condition-based maintenance optimization applied to wind turbine blades," IEEE Trans. SustainableEnergy, vol. 1, no. 2, pp. 77–83, Jul. 2010.
- [12] M. Ceraolo, "New dynamical models of lead-acid batteries," IEEE Trans. Power Syst., vol. 15, no. 4, pp. 1184–1190, Nov. 2000.
- [13] C. A. Shepherd, "Design of primary and secondary ceils—II. An equation describing battery discharge," J. Electrochem. Soc., vol. 112, no. 7, pp. 657–664, 1965.
- [14] J. B. Copetti, E. Lorenzo, and F. Chenlo, "A general battery model for PV system simulation," Prog. Photovoltaics, Res. Applicat., vol. 1, pp. 283–292, 1993.
- [15] A. Delaille, F. Huet, E. Lemaire, F. Mattera, M. Perrin, and M. Vervaart, "Development of a battery fuel gauge based on ampere-hour counting," in Proc. 21st Eur. Photovoltaic Solar Energy Conf., Dresden, Germany, Sep. 4–8, 2006.
- [16] C. Venu, Y. Riffonneau, S. Bacha, and Y. Baghzouz, "Battery storagesystem sizing in distribution feeders with distributed photovoltaic systems,"in Proc. IEEE Powertech Conf., Roumania, Bucarest, 2009.
- [17] Jun-Hai Shi, Xin-Jian Zhu and Guang-Yi Cao. Design and techno-economical optimization for stand-alonehybrid powersystems with multi-objective evolutionaryalgorithms. international journal of energy research 2007; 31:315–328
- [18] Celik AN. Optimization and techno-economic analysis of autonomous photovoltaic-wind hybrid energy systems incomparison to single photovoltaic and wind systems. Energy Conversion and Management; 2002: 43:2453–2468