

# Hybrid Control Strategy for Variable Speed Wind Turbine Power Converters

Kenneth E. Okedu<sup>\*,\*\*‡</sup>

<sup>\*</sup>Department of Electrical and Electronic, Faculty of Engineering, University of Port Harcourt

<sup>\*\*</sup>Massachusetts Institute of Technology, MIT International Science and Technology Initiatives (MISTI)

kenokedu@mit.edu

<sup>‡</sup>Corresponding Author; Kenneth E. Okedu, Amherst Street, E40 433, Cambridge, Massachusetts, USA,  
+16178066256, kenokedu@mit.edu

*Received: 28.01.2013 Accepted: 26.03.2013*

**Abstract-** This article employs a hybrid control strategy for variable speed wind turbine power converters. A voltage-controlled voltage source converter algorithm was used in the machine or rotor side of the variable speed wind turbine system. For the grid or stator side of the variable speed wind turbine, a current-controlled voltage source converter method was used. The effectiveness of the hybrid converter system was compared with those using only voltage or current controlled power converters for the variable speed wind turbine in a standard laboratory power simulation package of the Manitoba Research Centre in Canada (PSCAD/EMTDC). It is palpable and discernable from the results that the hybrid control strategy improves the performance of the variable speed wind turbine stability during transient compared to when only the voltage-controlled algorithm was used for the power converters. However, when only the current-controlled method is applied for the variable speed wind turbine power converters, the transient stability of the variable speed wind turbine was slightly improved compared to the hybrid converter system.

**Keywords-** Voltage-controlled voltage source converter; Current-controlled voltage source converter; Wind energy; Power converter; Transient analysis.

## 1. Introduction

Wind energy is a popular renewable energy source. The doubly fed induction generator (DFIG) is widely used by all wind generator manufacturers in wind energy power generation [1, 2]. However, to analysis a DFIG system, a simulation model is useful. DFIG is a variable speed wind generator with many advantages compared to other solutions of wind energy conversion system [3]. It is used more in wind turbine applications due to easy controllability, high energy efficiency and improved power quality. The induction generator and fixed speed generators has the disadvantages of having low power efficiencies at most speeds. To improve the efficiency, controlled power electronics converters are commonly used. Voltage source converters or inverters are used to convert the voltage magnitude and frequency to match the grid values.

In the DFIG system, the power converters only deal with the rotor power, thus, electronics cost are kept low, about 20-30% of the total generator power. This is due to the fact that the rotor voltage is lower than the stator voltage. This implies that the converter is dimensioned to suit the rotor parameters, hence making the system more economical than using a full power rated converter in series configuration like other solutions [4-7].

This work presents a hybrid control system for the DFIG driven variable speed wind turbine system. The hybrid converter control for DFIG variable speed wind turbine uses a voltage-controlled voltage source converter in the machine or rotor side and a current-controlled voltage source converter in the grid or stator side. The mathematical analysis and detailed control structures of the different strategies used for the voltage source converters were presented.

Results obtained using the hybrid converter strategy was compared with those using only the voltage or current controlled strategies. Better performance was achieved using the hybrid system during transient analysis of the variable speed wind turbine for a severe three line to ground fault. However, the current-controlled voltage source converter can further enhance the stability of the variable speed drive during the grid fault as reported in [8-10].

**2. Variable Speed Drive Equations**

The drive system operates in four quadrants. By this, it implies that a bidirectional flow of power is possible. The possibility of supplying and consuming reactive power enables the variable generator system to act as a power factor compensator. The controlling of the back to back converters enables the control of the slip also. In the case of the double cage squirrel induction machine, for instance, as the rotor cannot be driven, the slip only depends on the stator and load inputs. For synchronous machines, a relatively large torque may cause the machine to oscillate [11, 12]. The variable speed wind turbine that is driven by DFIG does not pose any synchronization problems.

Equations of the variable speed machine are presented as follows in the arbitrary reference frame speed ( ) based on [13]. The equations may be rewritten in the desired reference frame by replacing the arbitrary reference frame speed ( ) with the reference frame speed in light of [14-16].

The stator equation is presented as follow:

$$u_s = R_s i_s + \frac{d\psi_s}{dt} + j\omega_e \psi_s \tag{1}$$

Where,

$u_s$  is the stator voltage space vector

$i_s$  is the stator current space vector

$R_s$  is the stator resistance

$\psi_s$  is the stator flux

$\omega_e$  is the arbitrary reference frame speed

$j$  is a complex operator

The stator voltage may be expressed as the sum of the stator d and q voltage components:

$$u_s = u_{sd} + j u_{sq} \tag{2}$$

The stator and rotor current space vectors are also expressed in d and q components as

$$i_s = i_{sd} + j i_{sq} \tag{3}$$

$$i_r = i_{rd} + j i_{rq} \tag{4}$$

The stator and rotor flux space vectors can be expressed as:

$$\psi_s = \psi_{sd} + j \psi_{sq} \tag{5}$$

$$\psi_r = \psi_{rd} + j \psi_{rq} \tag{6}$$

The rotor voltage space vector equation is written for the rotor circuit as:

$$u_r = R_r i_r + \frac{d\psi_r}{dt} + j(\omega_e - \omega_r) \psi_r \tag{7}$$

Where,

$R_r$  is the rotor equivalent resistor and

$\omega_r$  is the rotor speed

$$u_r = u_{rd} + j u_{rq} \tag{8}$$

$$\psi_s = L_s i_s + L_m i_r \tag{9}$$

$$\psi_r = L_r i_r + L_m i_s \tag{10}$$

Where,

$L_m$  is the magnetizing inductance and

$L_s, L_r$  are the stator and rotor inductances

$$L_s = L_m + L_{s\sigma} \tag{11}$$

$$L_r = L_m + L_{r\sigma} \tag{12}$$

Where,

$L_{s\sigma}$  is the stator leakage inductance and  $L_{r\sigma}$  is the rotor leakage inductance.

The mechanical equation comprising the rotor inertia J, load torque  $T_L$ , electromagnetic torque  $T_e$  and the rotor speed  $\omega_r$  is written as follows:

$$J \frac{d\omega_r}{dt} = T_e - T_L \tag{13}$$

The electromagnetic torque is a function of the machine pole pairs (p) and the stator currents and fluxes:

$$T_e = \frac{3}{2} p (\psi_{sd} i_{sq} - \psi_{sq} i_{sd}) \tag{14}$$

Space vector representation of the machine is preferred due to the fact that the control strategies involve managing the d and q components of the system.

**3. Description of the Variable Speed drive and Controllers**

A dynamic model is normally needed to observe the flow of active and reactive power and the variable speed drive system. The machine may be simulated as an induction machine having 3 phase supply in the stator and three phase supply in the rotor [17]. The rotor circuit is connected through slip rings to the back to back converter arrangement

controlled by the pulse width modulation (PWM) strategies, as shown in Figures 1 and 2 respectively. The voltage magnitude and power direction between the rotor and the supply may be varied by controlling the switch impulses that drive the insulated gate bipolar transistors (IGBTs) [18-20].

the machine to that of the grid system. The stator is connected directly to the grid [22-24]. The energy obtained by processing the wind speed as an input is fed into the network by both the stator and the rotor for a normal generation regime.

The electrical control of the converters and the mechanical control of the blade pitch angle are the two major control areas of the variable speed wind turbine system.

However, the variable speed wind turbine needs to be protected against electrical transients that might damage the layout components. The implementation of the protective strategies is normally referred to as the fault or low voltage ride through capability [25].

It should be noted that the variable speed drive turbine based on DFIG system shown in Figures 1 and 2, has windings on both the stator and the rotor. The stator is connected to the 3 phase supply mains. To match the stator voltages with the ones of the mains a 3 phase transformer could be used as shown [26]. The shaft of the generator receives mechanical power through a coupling. The mechanical power originates from the wind powered blades of the wind turbine, for practical case of wind application.

The difference between the voltage-controlled voltage source converter and the current-controlled voltage source converter control strategies for the variable speed drive shown in Figures 1 and 2 respectively could be defined as follows: (1) In terms of structure, the dq/abc transformation is done twice in the voltage-controlled voltage source

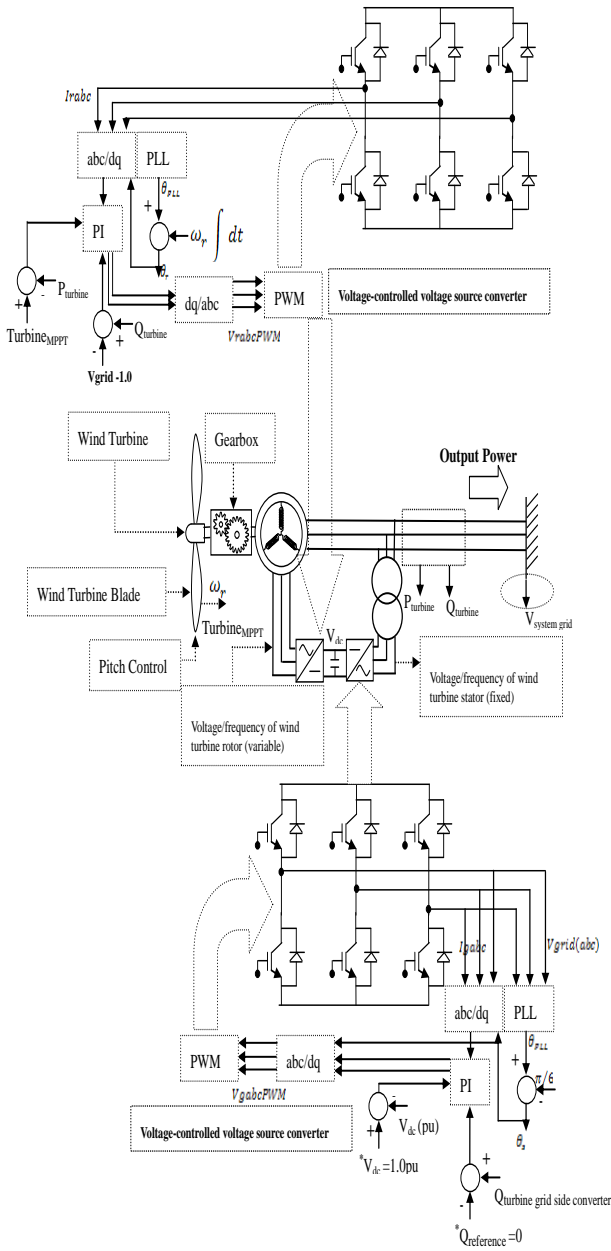

**Fig. 1.** Voltage-controlled voltage source converter strategy for variable speed drive wind turbine system.

The back to back converters shown in Figures 1 and 2 respectively, consists of two voltage source converters from ac to dc to ac, and having a DC-link capacitor connecting them. The machine or generator or rotor side converter takes the variable frequency voltage and converts it into DC voltage. The stator or line or grid side converter has the ac voltage from the DC-link as input and voltage at grid parameters as output [21].

The role of matching the speed between the blades and the rotor is done by the gearbox system. A transformer couples the generator to the grid and adjusts the voltage of

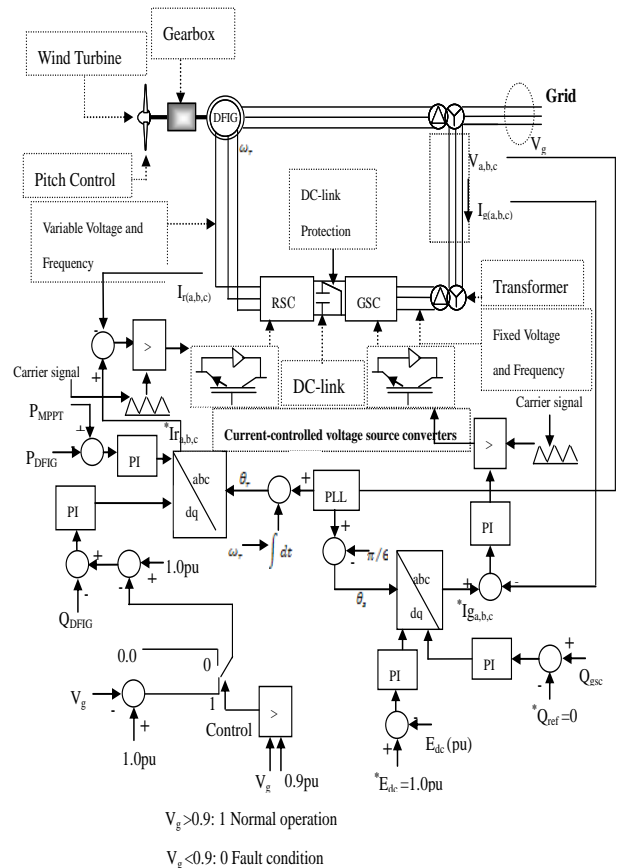

**Fig. 2.** Current-controlled voltage source converter strategy for variable speed drive wind turbine system.

-converter system, while once in the current-controlled voltage source converter system. (2) Consequently, from (1), the current-controlled voltage source converter has fewer intricacies in converter design, reduced components, lower cost and better performance during transient as presented in the simulation results.

Details of the voltage and current controlled control strategies for the variable speed drive and their responses in a multi-machine system during transient could be referred to in [8-10].

This work focuses on the hybrid system that is shown in Figure 3. The hybrid system falls between the voltage-controlled voltage source converter and the current-controlled voltage source converter system, because the variable speed drive wind turbine uses both of them for its rotor or generator or machine side and its stator or line or grid side converters respectively.

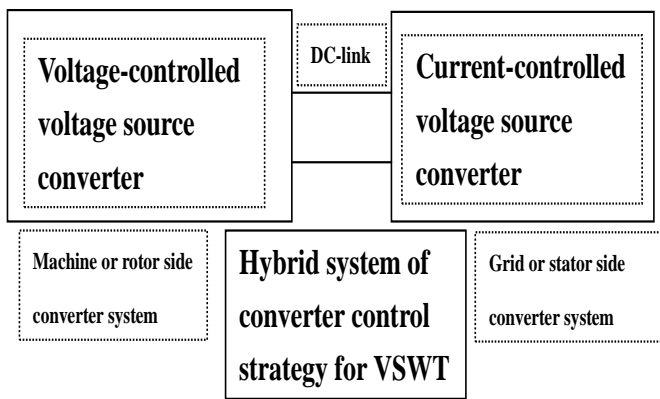

Fig. 3. Hybrid converter strategy for variable speed drive wind turbine system.

4. Simulation Analysis

A simulation standard laboratory package named power system computer aided design and electromagnetic transient including DC (PSCAD/EMTDC) [27], was used in this study. A simulation time step of 0.000001 sec was chosen for all the converter control strategies. The simulation was run for 5 sec and a severe case fault was considered, in which a three line to ground fault (3LG) occurred on the faulted line. At 100 ms of simulation run, the fault occurred for duration of 0.1sec. The circuit breakers operation sequences are as follows: the first and second circuit breakers on the faulted line open at 200 ms and recloses at 1000 ms respectively.

As seen in Figure 4, the introduction of the current-controlled voltage source converter in the grid or line or stator side of the variable speed wind turbine power converter system, improved the performance of the terminal voltage of the variable speed wind turbine during transient, compared to when only voltage-controlled voltage source converter was used in both converters.

Also, it is clearly seen from the simulated result in Figure 4 that, the performance of the variable speed wind turbine was further improved when the current-controlled

voltage source converter strategy was introduced in both power converters (i.e. rotor and grid side converters).

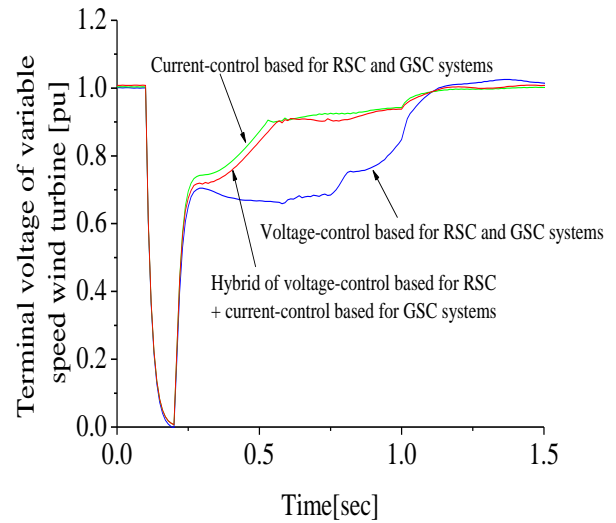

Fig. 5. Variable speed wind turbine terminal voltage

The response of a study case, where a fixed speed wind turbine that uses a double cage induction generator connected to the point of common coupling of the variable speed wind turbine is shown in Figure 5. From Figure 5, it is clear that the type of control strategy employed in the variable speed wind turbine power converter system do not only affect the variables of the variable speed drive, but also any other machine connected to the variable speed drive. An improved performance during transient condition was achieved also using the hybrid control strategy, though the current-controlled voltage source converter strategy on both power converters gave the best result.

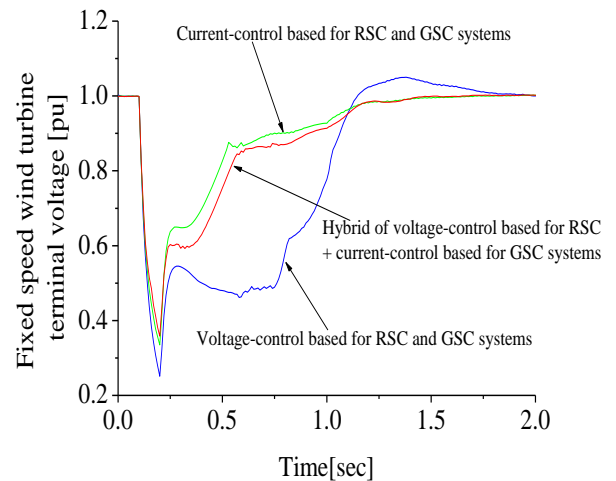

Fig. 6. Fixed speed wind turbine terminal voltage

4.1. Transient Stability Analysis of a System using the Various Controllers

This section discusses the transient stability of the various controllers used in this study. This is an additional convincing technique of the presented simulation results above. The parameters and model system used in testing this

analysis follow those used in [8], where DFIGs with the various controllers are connected to a multi-machine system composing of synchronous generators.

The transient stability index,  $W_c$ , [28] defined as follows is used in evaluating the transient stability of the system:

$$W_c(\text{sec}) = \int_0^T \text{abs}\left(\frac{d}{dt} W_{\text{total}}\right) dt / \text{system base power} \tag{15}$$

Where T is the simulation time (10.0sec here), and  $W_{\text{total}}$  is the total kinetic energy calculated by using the rotor speed of each synchronous generator as follows:

$$W_{\text{total}} = \sum_{i=1}^N W_i(J) \tag{16}$$

$$W_i = \frac{1}{2} J_i \omega_{mi}^2(J) \tag{17}$$

Where N is the number of synchronous generators, and  $J_i$  denote inertia moment and rotor speed of each synchronous generator. The smaller the value of  $W_c$ , the better the system transient stability. The transient stability index against 1LG (one-line-to-ground fault), 2LS (line-to-line fault), 2LG, and 3LG faults considering VC-VSC, CC-VSC and the proposed hybrid control VSC of DFIG control are shown in Table 1, for the different fault points in the model system. From these results it can be understood that the proposed hybrid VSC DFIG control and the CC-VSC DFIG control can improve the transient stability of the entire power system relatively compared to the VC-VSC DFIG control system.

**Table 1.** Transient Stability Index [ $W_c$ (s)] of a System

Fault	With VC-VSC Controlled DFIG			With Hybrid VSC Controlled DFIG			With CC-VSC Controlled DFIG		
	Fault Location			Fault location			Fault Location		
	F1	F2	F3	F1	F2	F3	F1	F2	F3
3LG	4.86	3.98	4.62	3.42	2.57	3.19	3.39	2.50	3.11
2LG	3.42	2.32	3.34	3.08	1.70	2.86	2.88	1.64	2.49
2LS	2.98	2.31	2.81	2.48	1.72	2.11	2.41	1.65	2.07
1LG	2.23	1.66	2.22	1.82	1.24	1.89	1.78	1.19	1.56

**5. Conclusion**

The performance evaluation of a hybrid power converter algorithm for a variable speed wind turbine has been presented in this paper. The hybrid power converter uses a voltage-controlled voltage source converter at the rotor or machine or generator side converter of the variable speed wind turbine, while the stator or grid or line side converter uses a current-controlled voltage source converter. The transient performance is evaluated with a three line to ground (3LG) fault which is a severe case or worst condition using the hybrid converter system and two other converter strategies that uses only voltage or current controlled voltage source converters in the variable speed wind turbine.

The results obtained in this study displays that, the hybrid system gives better performance of the variables of

the wind turbine during transient compared to responses obtained using only voltage-controlled voltage source converters for the variable speed wind turbine. However, the transient responses of the wind turbine variables could slightly be improved, when only current-controlled voltage source converter is used for the variable speed wind turbine system.

**Acknowledgements**

The author would like to acknowledge Prof. Junji Tamura of the Kitami Institute of Technology, Japan, who was his PhD supervisor.

**References**

- [1] T. Brekken, and N. Mohan, "A novel doubly-fed induction wind generator control scheme for reactive power control and torque pulsation compensation under unbalanced grid voltage condition", Power Electronics Specialist Conference, PESC '03, 2003.
- [2] S. D. Muller and M. De Doncker, "Adjustable speed generators for wind turbines based on doubly-fed induction machines and 4-quadrant IGBT converters linked to the rotor", Industry Applications Conference, Conference Record of the 2000 IEEE, ISBN: 0-7803-6401-5 DOI: 10.1109/IAS.2000.883138, 2000.
- [3] P.W. Carlin, A. X. Laxson, and E. B. Muljadi, "The history and state of the art of variable speed wind turbine technology", National Renewable Energy Lab., Tech. Rep. NREL/TP-500-28 607, 2001.
- [4] L. Yazhou, A. Mullane, G. Lightbody, and R. Yacamini, "Modeling of wind turbine with a doubly fed induction generator for grid integration studies", IEEE Transactions on Energy Conversion, vol. 21, no. 1, pp. 257-264, 2006.
- [5] V. Akhmatov, "Variable speed wind turbine with doubly fed induction generators, Part 1: modeling in dynamic simulation tools", Wind Engineering, vol. 26, no. 2, pp. 85-108, 2002.
- [6] M. Machmoum, R. L. Doeuff and F. M. Sargos, "Steady state analysis of a doubly fed asynchronous machine supplied by a current controlled cyclo-converter in the rotor", Proceedings of Institute of Electrical Engineering, vol. 139, no. 2, pp. 114-122, 1992.
- [7] P. G. Holmes, and N. A. Elsonbaty, "Cyclo-converter excited divided winding doubly fed machine as a wind power converter", Proceedings of Institute of Electrical Engineering, vol. 131, no. 2, pp. 61-69, 1984.
- [8] K. E. Okedu, S. M. Muyeen, R. Takahashi, and J. Tamura, "Wind farm stabilization by using DFIG with current controlled voltage source converters taking grid codes into consideration," IEEE Transactions on Power and Energy, vol. 132, no. 3, pp. 251-259, 2012.
- [9] K. E. Okedu, S M. Muyeen, R. Takahashi and J. Tamura, "Effectiveness of Current Controlled Voltage Source

- Converter Excited DFIG for Wind Farm Stabilization”, *Electrical Power Components and Systems (EPCS) Journal*, Taylor and Francis Publishing, vol. 40, no. 5, pp. 556-574, 2012.
- [10] K. E. Okedu, S. M. Muyeen, R. Takahashi R, and J. Tamura, “Comparative study on current and voltage controlled voltage source converter based variable speed wind generator”, *Proceedings of International Conference on Electric Power and Energy Conversion Systems (EPECS ‘2011)*, Sharjah, UAE, Vol. 2, pp. 1-6.
- [11] D. P. Sen Gupta, and J. W. Lynn, *Electrical Machine Dynamics*, Macmillan, ISBN: 0333138848, 1980.
- [12] I. Boldea, *Transformers and Electrical Machines*, Editura Politehnica Timisoara. ISBN: 973-9389-97-X, 2002.
- [13] J. G. Sloopweg, H. Polinder, and W. L. Kling, “Dynamic modeling of a wind turbine with doubly fed induction generator”, *Power Engineering Society Summer Meeting, IEEE*, ISBN: 0-7803-7173-9 DOI: 10.1109/PESS.2001.970114, 2001.
- [14] R. C. Pena, J. C. Asher, “Doubly fed induction generator using back-to-back PWM converters and its application to variable speed wind energy generation”, *Electric Power Applications, IEE Proceedings*, ISBN: 1350-2352. INSPEC Accession Number: 5292558, 1996.
- [15] M. Doradla, S. Chakrovorty and K. Hole, “A new slip Power Recovery Scheme with Improved Supply Power factor,” *IEEE Transactions on Power Electronic*, Vol. 3, no. 2, pp. 200- 207, 1998.
- [16] E. Tang, and L. Xu, “A flexible active and reactive power control strategy for a variable speed constant frequency generating system”, *IEEE Transactions on Power Electronic*, vol.10, no. pp. 472-478, 1995.
- [17] K. Pourbeik, R. J. Koessler, and D.L. Dickmader *Integration of wind farms into utility grids*, Ibid; Toronto, Canada, 2003.
- [18] I. Boldea, and A. Syed Nasar, *Vector control of AC drive* CRC, Press Florida, Boca Raton, Ann Arbor, London, Tokyo, 1992.
- [19] D. W. Novotny and T. A. Lipo, *Vector control and dynamics of AC drive*, Clarendon Press-Oxford, Oxford University Press, New York, 1996.
- [20] M. Andrzej Trzynadlowski, *The field orientation principle in control of induction motors*, Kluwer Academic Press, Boston, 1994.
- [21] A. Neris, N. Vovos, and G. Giannakopoulos, “A variable speed wind energy conversion scheme for connection to weak AC systems,” *IEEE Transactions on Energy Conversion*, vol. 14, no. 1, pp.122-127, 1999.
- [22] T. Sun, Z. Chen, and F. Blaabjerg, “Transient analysis of grid connected wind turbines with DFIG after an external short circuit fault,”*4th Nordic Wind Power Conference*. Chalmers University of Technology, Sweden, 2004.
- [23] R. J. Koessler, S. Pillutla, and L. H. Trinh, “Integration of large wind farms into utility grids (Part1- Modeling of DFIG),” *IEEE Power Engineering Society General Meeting*, Toronto, Canada, 2003.
- [24] J. Lianwei, O. Boon-Teck Ooi, J. G’eza, Z. Fengquan, “Doubly fed induction generator (DFIG) as a hybrid of asynchronous and synchronous machines,” *Electric Power System Research*, vol. 76, pp. 33-37, 2005.
- [25] *Grid Connection of Wind Turbines to Networks with Voltages below 100kV*, Regulation TF 3.2.6.Energinet, Denmark, 2004.
- [26] I. Boldea, and A. Syed Nasar, *Electric Drives*, 2nd Edition, CRC press Boca Raton, London, New York, Washington DC, 2005.
- [27] *PSCAD/EMTDC Manual*, Manitoba HVDC research center, 1994.
- [28] M. Yagami, S. Shibata, T. Murata and J. Tamura, “An analysis of superconducting fault current limiter for stabilization of synchronous generator in multi-machine system: A two-machine infinite bus system,” *IEEJ Trans. PE*, vol. 123, no. 2, pp. 133-142, 2003.