

Feasibility and Optimal Reliable Design of Renewable Hybrid Energy System for Rural Electrification in Iran

Farshid Mostofi*, Hossein Shayeghi**‡

*Department of Electrical Engineering, Ardabil Branch, Islamic Azad University

**Department of Technical Engineering, University of Mohaghegh Ardabili

fmos2fi@gmail.com, hshayeghi@gmail.com

‡Corresponding Author; Hossein Shayegh, Department of Technical Engineering, University of Mohaghegh Ardabili, Ardabil, Iran, hshayeghi@gmail.com

Received: 07.07.2012 Accepted: 17.08.2012

Abstract- A hybrid hydro/wind/photovoltaic base on hydrogen storage system is designed to supply power demand. The aim of the optimization problem is minimization of net present cost of the hybrid system to reliable supply of the demand. The system is investigated in the north west of Iran (Meshkinshahr) and the local data is applied. About 12 villages (corresponding to 680 people) are found in the upper Blue Qarahsou river gorge and far remote areas, which makes the task of their electrification via grid system very difficult. The hydro potentials are analyzed with the help of GIS data of Iran. Meteorological data from renewable energy organization (SUNA) of Iran and other sources, such as NASA, is used for the estimation of solar and wind energy potentials. In this paper, hydro/PV/wind/ fuel cell hybrid system is compared with above system without hydro unit. An advanced variation of genetic algorithm (GA) is proposed to solve the optimization problem. The developed algorithm is compared with HOMER software and the results show that GA accuracy is better than HOMER software. Result reveals the effects of components outages on the reliability and cost of the proposed hybrid system. Thus, they are directly dependent on component's reliabilities, i.e. Outages result need for a larger generating system for supplying the load with the acceptable reliability. Different system types and their component sizes are identified having a cost of energy less than 0.3 \$/KWh.

Keywords- Hybrid Renewable Energy System, Optimization, Rural Demand Supply, GA, HOMER software.

1. Introduction

Existence of problems in electricity transmission to remote region and it's high cost, also unsuitable condition in such region, make us to use other energy sources that are stand alone. There are some problems in use of renewable sources, the daily wind speed is not continual and solar irradiation cut-off at night and cloudy days, thus, the solar and wind hybrid system has a low reliability and can't supply the load at the peak times.

Several methods have been represented to minimization the cost of hybrid system. HOMER software has been used to simulation PV/micro hydroelectric hybrid system in the

north of Africa [2]. Several possible combinations of PV/wind generation capacities were obtained. The total annual cost for each configuration is then calculated and the combination with the lowest cost is selected to represent the optimal mixture. High cost of this method because of unsuitable combination is its problem. Moreover, HOMER Software has been suggested to minimization the cost of PV/wind/micro hydroelectric/diesel hybrid system in Malaysia [3]. This method had not considered the reliability; also use of diesel generator has environmental problems. In [4] use of micro hydroelectric and economic evaluation of it has been investigated. Another technique based on the evolutionary algorithms have been performed by Diaf et al. [5] for optimizing size of a PV/wind/fuel cell integrated

hybrid energy system. A methodology for optimum design of a hybrid PV/wind system has been reported by Koutroulis et al. [6]. The purpose of the methodology is to suggest, among a list of commercially available system devices, the optimum number and type of units ensuring that the 20-year round total system cost is minimized by Genetic Algorithm (GA) subject to the constraint that the load energy requirements are completely covered, resulting in zero load rejection. Yang et al. [7] proposed one optimum sizing method based on GA technique by using the typical meteorological year data. This optimization model is suggested to calculate the system optimum configuration which can achieve the desired LPSP with minimum annualized cost of system. Another heuristic technique based on the evolutionary algorithms has been performed by Ekren et al. [8] for optimizing size of a PV/wind integrated hybrid energy system with battery storage. The proposed methodology uses a stochastic gradient search for the global optimization. In the study, the objective function is the minimization of the hybrid energy system total cost. Bernal-Agustín et al. [9] present a multi-objective optimization (NPC versus CO₂ emissions) for a hybrid solar/wind/diesel system with battery storage based on Multi-Objective Evolutionary Algorithms (MOEAs). A triple multi-objective optimization to minimize simultaneously the total cost throughout the useful life of the installation, pollutant emissions (CO₂) and unmet load has been represented by Dufo-López and Bernal-Agustín [10]. For this task, a MOEAs and a GA have been used in order to find the best combination of components and control strategies for the hybrid system. According to the methods proposed by Chedid and Rahman [11] and Yokoyama et al. [12] the optimal sizes of the PV and wind power sources and the batteries are determined by minimizing the system total cost function using linear programming techniques. The total system cost consists of both the initial cost and yearly operation and maintenance costs. Yang et al. [13, 14] proposed an iterative optimization technique following the loss of power supply probability (LPSP) model for a hybrid solar-wind system. The number selection of the PV module, wind turbine and battery ensures the load demand according to the power reliability requirement, and the system cost is minimized. Similarly, an iterative optimization method was represented by Kellogg et al. [15] to select the wind turbine size and PV module number needed to make the difference of generated and Demanded Power (DP) as close to zero as possible over a period of time.

In this paper, with adding micro hydro electric system to PV/wind/fuel cell hybrid system, we increase the reliability of the system and the probability of supply the demand at the peak time. Furthermore, because of the low cost of micro hydro electric generators compared with PV panels and wind turbines the construction cost of system is decreased. In this way, a novel variation of GA and HOMER software is exploited to minimize costs of the system over its 20 years of operation, subject to reliability constraint. Wind speed and solar radiation data are available for Meshkinshahr province in North West of Iran (latitude: 38.17°, longitude: 48.15°, altitude: 1345 m), and system costs include Net Present Cost (NPC) of investment, replacement, and operation and maintenance, as well as costumers dissatisfaction costs.

Figure 1 shows the geographical layout of the project area. The hydropower potential is estimated with the help of recorded data obtained from GIS maps. The wind speed data is taken from NASA. Recorded sunshine data from the SUNA organisation of Iran is used to estimate the solar radiation at the site.

From this iterative procedure, GA method and HOMER software is used for optimization and reliability analysis of the small Hydro/PV/Wind/fuel cell hybrid system. Hydro, wind, solar and hydrogen data is input to optimization algorithm and HOMER software. In addition, the size, cost and lifetime of wind turbine, PV module, fuel cell, hydrogen tank, electrolyzer, converter and battery are defined. Furthermore, the installation cost, design flow rate and head of hydropower source are all input to the software. In the results feasible combinations of the hybrid components are displayed according to their net present cost in ascending order. In addition, the performance of each component cost of energy and reliability results can be observed from GA algorithm and HOMER output.

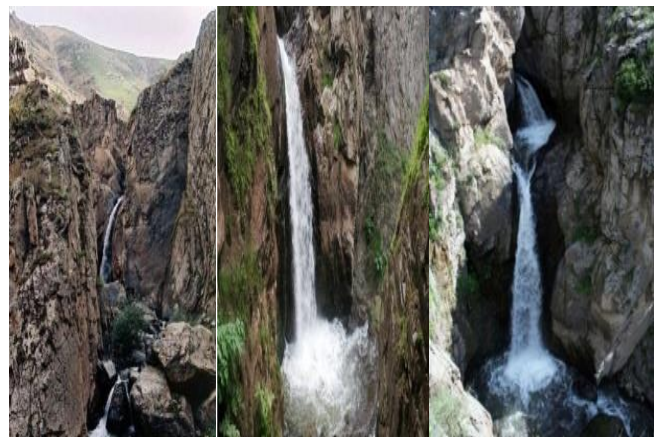

Fig.1.a. Sample photos taken during head measurement

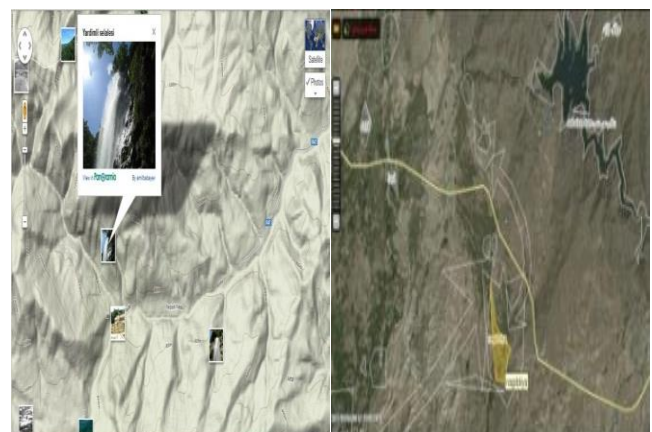

Fig.1.b. Geographical layout of the project area (Source: Google Map, 2012).

2. Micro Hydroelectric/ PV/Wind/Fuel Cell system

By using the local water, solar and wind potential we can supply the demand of consumers properly. The proposed system is combined of PV panels, hydro generators, wind

turbines, fuel cell, battery (to storage energy) and inverter to convert DC current to AC. As shown in Fig. 2, PV, WG, electrolyzer and battery bank are connected to DC bus and to AC bus with DC/AC converter. AC output connects to demand side to supply consumption.

Sizing optimization of a hybrid system is one of main parts of system design, because exceeding in sizing raises the cost mainly, conversely, small sizing of system reduces the reliability of system.

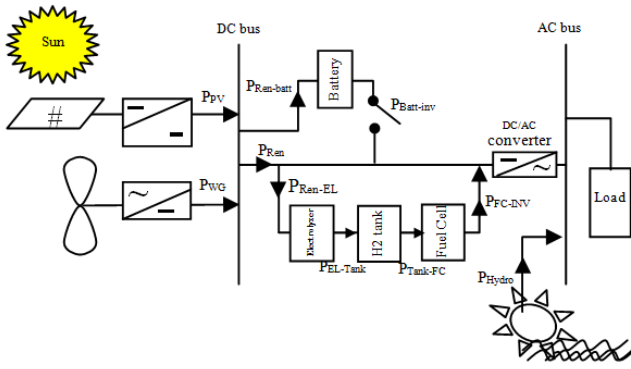

Fig.2. Block diagram of a hybrid hydro/PV/wind/fuel cell

2.1. Micro Hydroelectric System

The proposed hydropower system is runoff the river type which requires the determination of available head and flow rate at the pour points. Head can be measured using either of altimeters, pressure gauges, clear hose method, satellite images, sighting meter or level method [1]. In the this study, the selected sites have steep waterfalls so that their head is measured using rope.

There are several values for the hydro capital cost for simulating the effect of a subsidy. The real value is \$6000. Since components are locally made and the lifetime is not high, the replacement cost is also important. The turbine envisaged is a Banki turbine. Thus, we have simulated multiple values of the design flow rate to evaluate its influence on the system. The monthly flow data are obtained from the daily data (Table 1).

We measured two main parameters of local water, head of water (5m) and water flow 129 L/s or 0/129 m³/s. The potential of available water sources is calculated as follows:

$$P_{total} = P_h \times \eta_t \times \eta_g \tag{1}$$

Where, η_t is the turbine efficiency, η_g is the generator efficiency and P_h is the hydraulic power. The theory output power due to the turbine location is calculated as follows:

$$P_h = C_w \times \rho_e \times g \times h_f \tag{2}$$

Where, C_w is the water density, ρ_e is the coefficient of electrical discharge, g is the gravitational acceleration and h_f is the water head. With consideration the region topology and hydrologic information, Kaplan turbine (small scale and

high speed) has been used. The efficiency of turbine, regarded to the kind of turbine and its technical properties is equal to 0.9.

To produce variable speed, induction generator has been used. Because its rotor's speed is variable compared with the synchronic type [2], the generator efficiency is up to 0.9. The corresponding characteristics of generator are presented in Table 1.

Table.1. Generator Characteristics

Type	Nominal power	Efficiency	Frequency	Power Factor	Synchronic Speed	Rotor Speed	Rotor Inertia
Induction generator	7.5 KW	0.9	50Hz	0.8	1500 rpm	1560 rpm	0.02

2.2. PV Array

The output power of PV can be calculated by equations 3 to 5. In this model the effects of solar irradiation and environment temperature on the output power has been considered [3]. These equations in Maximum Power Point (MPP) are as follows:

$$P_{pv} = V_{mpp} \times I_{mpp} \tag{3}$$

$$V_{mpp} = V_{mpp,ref} \times P_{v,oc} (T_c - T_{c,ref}) \tag{4}$$

$$I_{mpp} = I_{mpp,ref} \times I_{sc,ref} (T_c - T_{c,ref}) \tag{5}$$

Where, P_{pv} is the panels power, V_{mpp} is the potential voltage, $V_{mpp,ref}$ is the V_{mpp} at standard condition (V), I_{mpp} and $I_{sc,ref}$ are the panel's current and short circuit current at standard condition, respectively and $P_{v,oc}$ is the open circuit (V/°c) temperature coefficients. $T_{c,ref}$ is the temperature of panel at standard operational condition that is equal to 250°c and T_c is the operational temperature of panel that is calculated as follows:

$$T_{C(t)} = T_{a(t)} + \frac{NOCT - 20}{800} \cdot G_T \tag{6}$$

Where, $T_{a(t)}$ is the ambient temperature (°C), $NOCT$ (Normal Operational Cellular Temperature), for 500 W/m² of solar irradiation and temperature of 20°c is in the range of 40 to 46°c and G_T is the average daily solar irradiation (W/m²).

2.3. Wind Turbine

The daily average speed at height of h_r has been used to calculate the strike speed to the turbine's blade. The turbine's model is given as follow:

$$V_{(t)} = V_{r(t)} \left(\frac{h}{h_r} \right)^r \tag{7}$$

Where, $V_{(t)}$ is the wind speed at height of h , $V_r(t)$ is the wind speed at height of h_r and r is the power-law exponent that is in the range of 0.14 to 0.25. This formula of wind speed is used to calculate the out-put power of the turbine, $P_{wt(t)}$, as follows:

$$P_{wt(t)} = \begin{cases} aV^3(t) - bP_R & V_{ci} < V < V_r \\ P_R & V_r < V < V_{co} \\ 0 & otherwise \end{cases} \quad (8)$$

Where:

$$a = \frac{P_r}{(V_r^3 - V_{ci}^3)}, \quad b = \frac{V_{ci}^3}{(V_r^3 - V_{ci}^3)}$$

and P_r is the rated power of the wind turbine (w) and V_{ci} , V_r , V_{co} are the cut-in wind speed, rated wind speed and cut-out wind speed of the wind turbine, respectively. The output power diagram of wind speed is shown in Fig.3.

2.4. Fuel Cell

Fuel cell is an electrochemical device that converts the chemical energy of a reaction into electrical energy. The output power of fuel cell is calculated as follows:

$$P_{FC-INV} = P_{Tank-FC} \times \eta_{FC} \quad (9)$$

Where, $P_{Tank-FC}$ is the delivered hydrogen power to the fuel cell and η_{FC} is the fuel cell efficiency.

2.5. Electrolyzer

Electrolyzer works through simple water electrolysis: a direct current is passed between two electrodes submerged in water, which thereby decomposes into hydrogen and oxygen. The hydrogen can then be collected from the anode. Most electrolyzers produce hydrogen at a pressure around 30 bars [4]. As a result, in most studies, electrolyzer's output is directly injected to a hydrogen tank. However, in some cases, for raising the density of stored energy, a compressor may pressurize electrolyzer's output up to 200 bar. In this configuration, electrolyzer's output is directly injected to a low-pressure tank and when this tank is fully charged, compressors pump the hydrogen into a second high-pressure tank. Thus, compressor does not work continuously and, as a result, it consumes lower amount of energy. In this paper, the electrolyzer is directly connected to the hydrogen tank; however, the developed software is flexible to handle the compressor model. Transferred power from electrolyzer to hydrogen tank can be given as follows:

$$P_{EL-Tank} = P_{Ren-EL} \times \eta_{EL} \quad (10)$$

where, P_{Ren-EL} is the electrolyzer input power, and η_{EL} is the electrolyzer efficiency. In this paper η_{EL} has been assumed constant in the operational period time.

2.6. Hydrogen tank

The storage energy in the hydrogen tank is calculated as follows:

$$E_{Tank(t)} = E_{Tank(t-1)} + (P_{EL-Tank} \times \Delta t) - (P_{Tank-FC} \times \Delta t \times \eta_{storage}) \quad (11)$$

Where, $P_{Tank-FC}$ is the transferred power from the hydrogen tank to fuel cell $\eta_{storage}$ is the system's storage efficiency that is considered 95% [6]. The mass of stored hydrogen, at any time step t , is calculated as follows:

$$M_{storage} = \frac{E_{storage}(t)}{HHV_{H2}} \quad (12)$$

Where, the Higher Heating Value (HHV_{H2}) of hydrogen is equal to 39.7 KWh/kg [7]. The maximum volume of hydrogen storage depends on the hydrogen tank capacity. Also because of some technical problems (hydrogen pressure drop) all of the hydrogen cannot be extracting, therefore:

$$E_{Tank, \min} \leq E_{Tank}(t) \leq E_{Tank, \max} \quad (13)$$

2.7. Battery Model

The imported power in battery is calculated as follows:

$$\Delta P(t) = P_{ren}(t) - P_L(t) \quad (14)$$

Where, $P_{ren}(t)$ is the total energy has been generated by renewable resources and $P_L(t)$ is equal to:

$$P_L(t) = \frac{P_{Load}(t)}{\eta_{inv}} \quad (15)$$

Where, $P_{Load}(t)$ is the required power and η_{inv} is the DC/AC converter efficiency. State of Charge (SOC) of battery is calculated as follows:

$$SOC(t+1) = SOC(t) + \eta_{batt} \left(\frac{P_{batt}^i(t)}{V_{bus}} \right) \cdot \Delta t \quad (16)$$

Where, $SOC(t)$ is the value of storage energy in the battery at lost day and η_{batt} is the battery efficiency and $P_{batt}^i(t)$ is the total storage energy in the battery at the same day.

2.8. DC/AC Converter

Inverter is used to convert the generated DC power by hybrid system to AC power with desired frequency. To calculate the injected power to the load by converter, we use the following equation:

$$P_{INV-Load} = (P_{FC-INV} - P_{Ren-INV}) \times \eta_{INV} \quad (17)$$

Where, η_{INV} is the inverter's efficiency that is as inverter's losses.

The required data such as daily solar irradiation and wind speed diagrams is shown in Figs . 3-4 that are used with load profile in the simulation that shows in Fig .5. The cost of investment, repair and maintenance, replacement and operational is given in Table. A.1. To compare the obtained results from GA algorithm, we simulate the hybrid system by the HOMER software. The combination of component is shown in Fig .6.

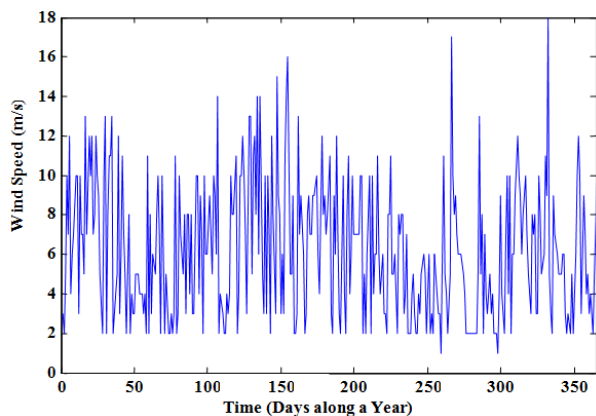

Fig. 3. Daily wind speed along a year

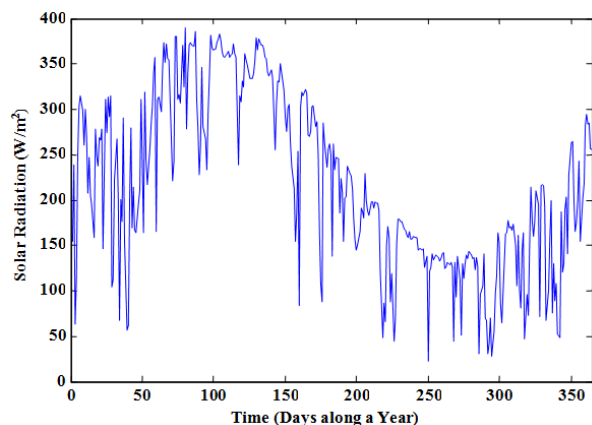

Fig. 4. Daily solar irradiation along a year

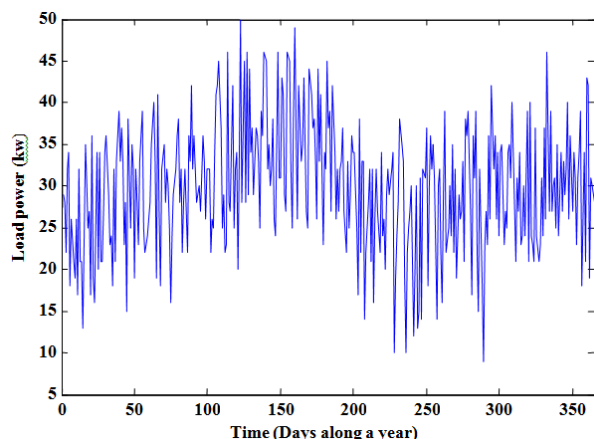

Fig. 5. load data profile along a year

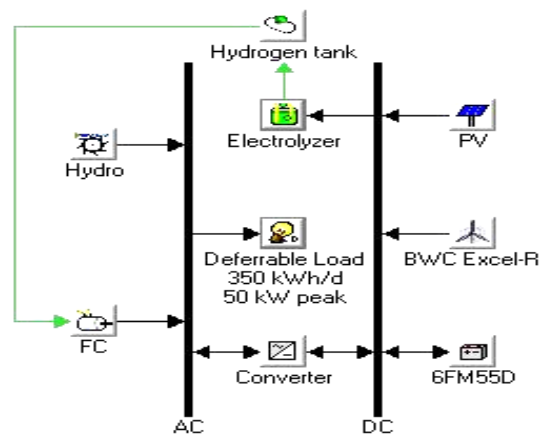

Fig. 6. hydro/PV/wind/fuel cell hybrid setup

3. Reliability of System

To get the real profit of renewable system and confidence of continual working of hybrid system to supply the load, we require calculating the system reliability.

Because of alternative energy production of PV/wind/fuel cell hybrid system, the reliability of system is reduced. Thus, the micro hydro electric is added to the above system to achieve high reliability and reduce the high cost of using PV panels and wind turbines. Several reliability indices has been used in previous method [15, 16, 17]. Loss of Load Expected (LOLE), Loss of Energy Expected (LOEE) or Expected Energy not Supplied (EENS), Loss of Power Supply Probability (LPSP), and Equivalent Loss Factor (ELF) are some of common used method in the reliability evaluation of generating system. LPSP is defined as the probability that an insufficient power supply results when the hybrid system (hydro system, PV array, wind turbine and hydrogen storage) is unable to satisfy the load demand [16]. It is a feasible measure of the system performance for an assumed or known load distribution.

From these methods, ELF is used to evaluation the reliability of system; furthermore, LOLE is a loss of load index, whereas other belongs to category of loss of energy indices. These two methods are defined in following sections.

3.1. Equivalent Loss Factor

$$ELF = \frac{1}{N} \sum_{i=1}^N \frac{Q(t)}{D(t)} \quad (18)$$

Where, N is the number of time steps in which system's reliability is evaluated (here, N=365). $Q(t)$ and $D(t)$ are total loss of load and total demand respectively at the t time step. ELF is chosen as the main reliability index of this study and its value for rural areas and stand-alone applications is equal to $ELF < 0.01$ [20].

3.2. Loss of Load Expected

$$LOLE = \sum_{t=1}^N E[LQL(t)] \quad (19)$$

Where, $E[LQL(t)]$ is the expected value of loss of load at time step t .

3.3. Loss of Energy Expected

$$LOEE = \sum_{t=1}^N E[LQE(t)] \quad (20)$$

Where, $E[LOE(t)]$ is the expected value of loss energy, or energy not supplied, at time step t .

3.4. Loss of Power Supply Probability

$$LPSP = \frac{LOEE}{\sum_{t=1}^N D(t)} \quad (21)$$

Where, $D(t)$ is the load demand (KWh) at time step t .

4. System Optimization Model with Genetic Algorithm

A Genetic Algorithm (GA) is an advanced search and optimization technique. It has been developed to imitate the evolutionary principle of natural genetics. Compared with traditional methods (the direct exhaustive search method and the gradient-directed search method) for function optimization, one of the main advantages of the GA is that it is generally robust in finding global optimal solutions, particularly in multimodal and multi-objective optimization problems. Generally, a GA uses three operators (selection, crossover and mutation) to imitate the natural evolution processes. The first step of a genetic evaluation is to determine if the chosen system configuration (called a chromosome) passes the functional evaluation, provides service to the load within the bounds set forth by the loss of power supply probability. If the evaluation qualified chromosome has a lower Net Present Cost (NPC) of system than the lowest NPC value obtained at the previous iterations, this system configuration (chromosome) is considered to be the optimal solution for the minimization problem in this iteration. This optimal solution will be replaced by better solutions, if any, produced in subsequent GA generations during the program evolution. After the selection process, the optimal solution will then be subject to the crossover and mutation operations in order to produce the next generation population until a pre-specified number of generations have been reached or when a criterion that determines the convergence is satisfied.

5. The objective function and optimization of system

The output of optimization algorithm in the proposed methodology is the number of PV panels, wind turbines, inverter, battery, fuel cells power, the electrolyzer power, capacity of hydrogen tank, the micro hydro electric power,

number of battery charger and optimum height of wind turbine installation. These parameters will be optimized to minimize the total cost of system at 20 year life time. The total cost of system i.e.: NPC(\$\$) includes of the capital cost and replacement cost and operation and maintenance costs. The objective function is given as follows:

$$\min\{NPC\} = \min\{\sum_S NPC(S)\} \quad (22)$$

$$NPC(S) = N \times (Capital\ Cost + (replacement\ Cost \times k)) + \left(Operation\ \&\ Maintenance\ Cost \times \frac{1}{CRF(ir, \pi)} \right)$$

Where:

$S = \{hydro, PV, WG, Batt, FC, EL, Tank, INV, Batt-ch, h\}$

Also, CRF and K are capital recovery factor and single payment present worth, respectively, which are defined as follows:

$$K = \sum_{n=1}^y \frac{1}{(1+ir)^{L \times n}} \quad (23)$$

$$y = \begin{cases} \left[\frac{R}{L} \right] - 1: & \text{if } R \text{ is dividable to } L \\ \left[\frac{R}{L} \right]: & \text{if } R \text{ is not dividable to } L \end{cases} \quad (24)$$

$$CRF(ir, R) = \frac{ir(1+ir)^R}{(1+ir)^R - 1} \quad (25)$$

Where, ir is a discount rate and R is the useful lifetime of the energy system. Considering the methodology of optimization, the proposed algorithm is shown in Fig.7.

6. Results and Discussion

The case study was are of Ardabil's remote area (north west of Iran), the water flow of river in this area obtained through the GIS maps and its value is variable in the range of 46-132L/s with the annual average equal to 129 L/s. The best height for water in this area is 5 m and water flow in this point is 129 L/s. Thus, it is the optimum place to install micro hydro generators. To simulate the hybrid system with HOMER information on water flow, solar irradiation and wind speed applied as monthly average. The load demand in this area is 50KW at peak time. The applied constraints in the simulation are supplying the load with high reliability.

To reach the optimum combination of component's we use MATLAB and HOMER software. In MATLAB we run the proposed algorithm with population of 60 and 200 iteration. With adding the micro hydro system to PV/wind/hydrogen hybrid system we raise the reliability of system as well as the cost of construction of system with micro hydro is 222856 (\$) is less than the cost of system without micro hydro system 268019 (\$\$).

Since reliable supply of the load at each time step, strongly depends on the amount of the stored energy, the daily expected amount of stored energy in the hydrogen tank,

during the year is shown in Fig. 8. It is evident that loss of load is mostly probable at the days that stored mass of hydrogen reaches to its minimum allowable limit. Figures 9 and 10 present the variation of the system total cost (fitness function) during the optimization procedure without and with hydro system, respectively. Also, amount of the hourly demand, in addition to the conditions of the stored energy, is another important factor in reliability assessment of the system. This fact is illustrated in Fig .11, where the daily reliability indices of the base case system are presented. This figure confirms that LOLE can't be a suitable index for reliability evaluations of such a hybrid system. In fact, this index only calculates the loss of load probability, regardless of the amount of load which is not supplied. In contrary, LOEE and ELF can be considered as useful indices in reliability evaluations of energy based generating systems. The results show that the optimized configuration produces high efficiency for LPSP of 1.23%. The optimal sizing method can also be applied to design systems whose power source consists either only of PV/Wind/fuel cell system. And the optimal sizing results for hybrid PV/Wind/fuel cell are given in Table. 3. It is obvious that in both cases, the optimal configurations result in a higher net present cost of system compared to the hybrid Hydro/PV/Wind/fuel cell system given in Table 3.

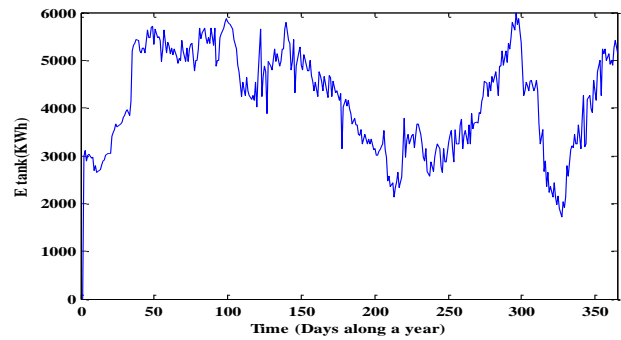

Fig. 8. Daily expected amount of stored energy in the hydrogen tank during a year.

Table. 3. simulation results of system

parameters	N_{PV}	N_{WG}	P_{FC} (kw)	P_{EL} (kw)	M_{Tank} (kg)	N_{Batt}	P_{hydro} (kw)	P_{INV} (kw)	$N_{Batt-ch}$	H (m)	$LPSP$ (%)	Cost (\$)
Optimal Results without hydro	14	9	8	12	4.6	64	-	23	6	18	1.96	268019
Optimal Results with GA With hydro	8	4	13	14	6.2	45	21.8	26	5	17	1.23	222856

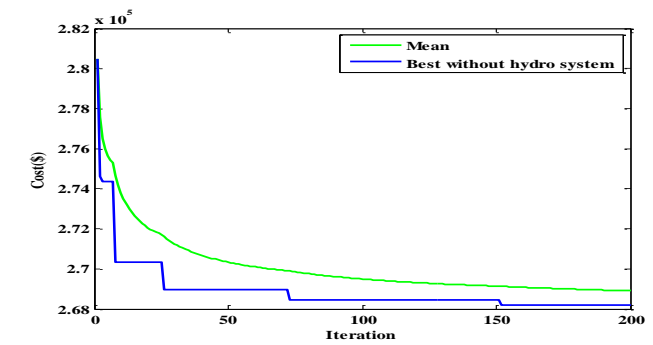

Fig. 9. Convergence of the optimization algorithm without hydro system.

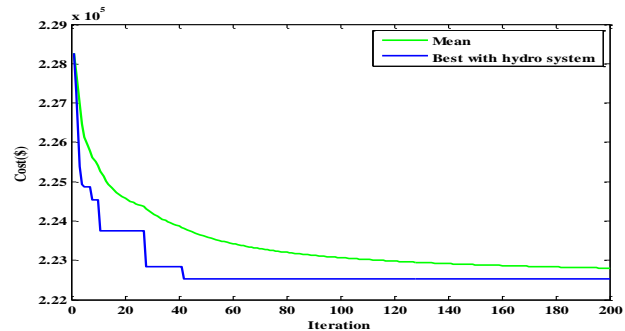

Fig. 10. Convergence of the optimization algorithm with hydro system.

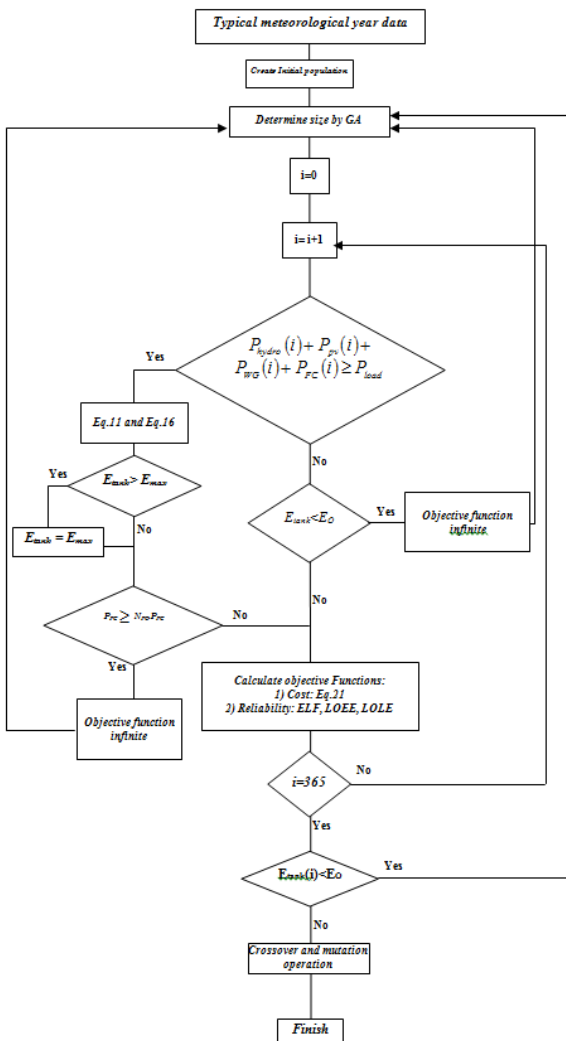

Fig.7. GA used for optimization process

We also use the HOMER software to simulation the proposed hybrid system. The optimization results of HOMER are presented in Figures (12.a and 12.b). The HOMER results show the strength of GA algorithm in calculation the minimum cost. Besides having high reliability of system, because of low cost hydro generators compared with PV panels and wind turbines, the cost difference between system with and without micro hydro is 45163\$. Furthermore the cost of energy (COE) in the system without micro hydro is 0.284(\$/KWh), whereas this value for system with micro hydro is equal to 0.261(\$/KWh).

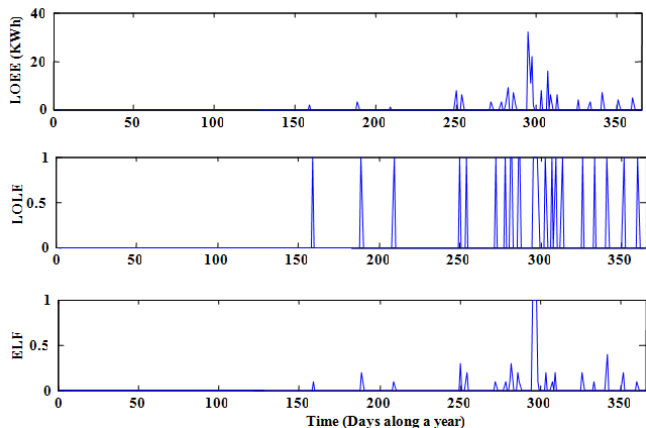

Fig. 11. Reliability indices of the base case system during a year.

PV (kW)	XLR	fc (kW)	S6CS25P	Conv. (kW)	Elec. (kW)	H2 Tank (kg)
12	9	10	45	16	5	12
Initial Capital	Operating Cost (\$/yr)	Total NPC	COE (\$/kWh)	Ren. Frac.	fc (hrs)	Batt. Lf. (yr)
\$ 235,583	3,934	\$ 271,288	0.284	1.00	23	12.0

Appendices

Table.A.1. Components specifications

Component	Capital cost (\$/unit)	Replacement cost (\$/unit)	O & M cost (\$/unit-yr)	Life time (yr)	Availability (%)	Efficiency (%)
Hydro	6000	2000	100	20	--	60
PV array	7000	6000	20	20	96	--
WG	19400	15000	75	20	96	--
Electrolyzer	2000	1500	25	20	100	75
Hydrogen tank	1300	1200	15	20	100	95
Fuel cell	3000	2500	175	5	100	50
Inverter	800	750	8	15	99.89	90

References

[1] J. Kenfack, F.P.Neirac, T.Tatietsse, D.Mayer, M. d.Fogue, A.Lejeune. "Microhydro-PV hybrid system: Sizing a small hydro-PV-hybrid system for rural electrification in developing countries", Renewable Energy 34 (2009) 2259-2263

[2] G. Bekele, B. Palm, "Wind energy potential assessment at four typical locations in Ethiopia", Applied Energy 2009; 86(3):388-96

[3] R. Luna-Rubio, M. Trejo-Perea, D. Vargas-Vázquez, G.J. Rios-Moreno. "Optimal sizing of renewable hybrids energy systems", A review of methodologies, Solar Energy 86 (2012) 1077-1088

[4] S. Diaf, "Design and techno-economical optimization for hybrid PV/wind system under various meteorological conditions", Applied Energy 85, 2008 (10), 968-987

Fig. 12.a. HOMER results without hydro system.

PV (kW)	XLR	Hydro (kW)	fc (kW)	S6CS25P	Conv. (kW)	Elec. (kW)	H2 Tank (kg)
12	6	10.3	10	36	14	15	40
Initial Capital	Operating Cost (\$/yr)	Total NPC	COE (\$/kWh)	Ren. Frac.	fc (hrs)	Batt. Lf. (yr)	
\$ 189,727	4,340	\$ 229,119	0.261	1.00	272	12.0	

Fig. 12.b. HOMER results with hydro system.

7. Conclusion

In this paper, an optimization model of hybrid energy system for a hybrid system implemented in the north part of Iran is presented. The optimization solution is provided by HOMER software compared with a solution given by a genetic algorithm implemented in MATLAB software. The paper presents an interesting source for the implementation of hybrid systems in isolate areas. The main purpose of combination PV, wind, fuel cell and hydro units is to reach a reliable applying with minimum initial and operation cost. The results show that the optimized configuration produces high efficiency for LPSP of 1.23%. Implementation of this energy system will supply the area's demand as well as it has no emissions and reduces the environment pollutions.

[5] E. Koutroulis, D. Kolokotsa, A. Potirakis, K.Kalaitzakis "Methodology for optimal sizing of stand-alone photovoltaic/wind-generator systems using genetic algorithms", Solar Energy 2006; 80(9):1072e88

[6] Yang HX, Zhou W, Lu L, Fang ZH, "Optimal sizing method for stand-alone hybrid solar-wind system with LPSP technology by using genetic algorithm", Solar Energy 2008; 82(4):354e67

[7] O. Ekren, By. Ekren, "Size optimization of a PV/wind hybrid energy conversion system with battery storage using simulated annealing", Applied Energy 2010; 87(2):592e8

[8] JL. Bernal-Agustín, R. Dufo-López, DM. Rivas-Ascaso, "Design of isolated hybrid systems minimizing costs and pollutant emissions", Renewable Energy 2006; 31 (14):2227e44

[9] R. Dufo-López, JL. Bernal-Agustín, "Multi-objective design of PV/wind/diesel/hydrogen/battery systems", Renewable Energy 2008; 33(12):2559e72

- [10] R. Chedid, S. Rahman, "Unit sizing and control of hybrid wind-solar power systems", *IEEE Transactions on Energy Conversion* 1997; 12(1):79e85
- [11] Yokoyama R, Ito K, Yuasa Y, "Multi-objective optimal unit sizing of hybrid power generation systems utilizing PV and wind energy", *Journal of Solar Energy Engineering* 1994; 116:167e73
- [12] Yang. HX, Burnett. J, Lu. L, "Weather data and probability analysis of hybrid photovoltaic/wind power generation systems in Hong Kong", *Renewable Energy* 2003; 28:1813e24
- [13] Yang. HX, Lu. L, Zhou. W, "A novel optimization sizing model for hybrid solarewind power generation system", *Solar Energy* 2007; 81(1):76e84
- [14] W. Kellogg, MH. Nehrir, G. Venkataramanan, V. Gerez, "Generation unit sizing and cost analysis for stand-alone wind, photovoltaic and hybrid wind/PV systems", *IEEE Transactions on Energy Conversion* 1998; 13(1):70e5
- [15] A. Kashefi Kaviani, G.H. Riahy, SH.M. Kouhsari, "Optimal design of a reliable hydrogen-based stand-alone wind/PV generating system, considering component outages", *Renewable Energy* 34 (2009) 2380-2390
- [16] A. Kashefi Kaviani, G.H. Riahy, SH.M. Kouhsari, "Optimal design of a reliable hydrogen-based stand-alone wind/PV generation system", *Proceeding of 11th international conference on optimization of electrical and electronic equipment (OPTIM'08)*, Brasov, Romania; May 22-24, 2008
- [17] G.C. Ghosh, B. Emonts, D. Stolen, "Comparison of hydrogen storage with dieselgenerator system in a PV-WEC hybrid system", *Solar Energy* 2003; 75:187-98
- [18] M. Tanrioven, M.S. Alam, "Reliability modeling and analysis of stand-alone PEM fuel cell power plants", *Renewable Energy* 2006; 31:915-33
- [19] F. Mostofi, M. Javadi, G. Ghezeli, H. Shayeghi, J. Javidan, "Modeling and design of hybrid renewable energy sources for rural electrification", 17 th Electric Power Distribution Conference (EPDC) ,Tehran, Iran, May 12-13 (2012)
- [20] M.Bin. Gadhi Salem, A. Mnkbel Mohammed, "A review of renewable energy activities in Yemen", *Renewable Energy* 1998; 14(1-4):459-65
- [21] H. Shayeghi, M. Ghiami, F. Mostofi, S. Lotfi, "Optimal sizing a hybrid hydro-PV-Wind system via ACO algorithm, The first international & third national conference on dams & hydropower, Tehran, Iran.Feb8-9(2012).
- [22] A. Menshari, M.ghiami, F. Mostofi, "A novel method for reliability improvement for hybrid hydro/PV/wind system using ACO algorithm", *International Conference of Science, High Technology & Environmental Sciences*, Kerman, Iran, July 11-12(2012).