

Enver SAĞIR\* – Hüseyin UZUNOĞLU\*\* – Koncağül HANÇER\*\*\*

### Three new sarcophagi from Kios (Gemlik)

*Abstract:* Three sarcophagi (fig. 2) dated to the Roman Imperial Period were recently unearthed in Gemlik (ancient Kios) (fig. 1) in a rescue excavation conducted by Bursa Museum's Directorate. Several small objects found in these sarcophagi, grave goods, were delivered to the Archaeological Museum of Bursa, while the sarcophagi are today in the garden of the Directorate of Technical Works (Fen İşleri Müdürlüğü) in Gemlik. The sarcophagi resemble each other in their iconography and stylistically. Upon the *tabulae ansatae* there are three inscriptions, two are on the façade of the chests of two of these sarcophagi, the other is on the long side of the lid of the third. Amongst the finds from the first sarcophagus was a gold coin dated to the reign of Valerianus I and Gallienus. An intaglio carrying a depiction of Isis and Sarapis was found in the second sarcophagus which was carved on behalf of Marcus Iulius Aelianus Iulianus for Kladaios, both his friend and doctor, and for his freedman Harmodios. The inscription on the lid of the third sarcophagus records the owner as Aurelius Numerius and that he was a councillor in the city, providing the first attestation of a βουλευτής in Kios. The high penalty of 100,000 denarii for tomb violation is not commonly found in the inscriptions.

*Keywords:* Bithynia; Kios; sarcophagus; Gemlik; small finds; intaglio; Isis; Sarapis; Valerianus I; gold coin.

In May 2009, the Museum's Directorate of Bursa unearthed (fig. 2)<sup>1</sup> during a rescue excavation three sarcophagi from the Roman Imperial Period in the ancient city of Kios.<sup>2</sup> The excavation area is on the west side of the Gemlik–Kumla (fig. 1) main road and is surrounded by modern buildings to both the south and the west. The sarcophagi of differing sizes were placed side by side, all orientated in an east–west direction; in sequence, the largest (no. 1) to the northwest, the smallest (no. 3) in the middle, and the other (no. 2) to the northeast. All these sarcophagi are marble, and two of them carry inscriptions in *tabulae ansatae* on one of the short faces, while the other has an inscrip-

---

\* Enver Sağır, Bursa Arkeoloji Müzesi Müdürü, Bursa (enver\_sagir@hotmail.com).

\*\* Arş. Gör. Hüseyin Uzunoğlu, Akdeniz Üniversitesi, Edebiyat Fakültesi, Eskiçağ Dilleri ve Kültürleri Bölümü, TR–07058 Kampus, Antalya (huseyinuzunoglu@akdeniz.edu.tr).

\*\*\* Koncağül Hançer, Bursa Arkeoloji Müzesi, Müze Uzmanı–Arkeolog, Bursa.

This paper has been accomplished within the framework of the project “*The archiving of Epigraphical Materials in the Archaeological Museums of İzmit (Kocaeli), İzmit and Bursa*”(2009.01.0105.003), which was conducted under the supervision of Assoc. Prof. Dr. N. Eda Akyürek Şahin and supported by the Akdeniz University Scientific Research Projects Coordination Unit. I (Hüseyin Uzunoğlu) am very grateful to Assoc. Prof. Dr. N. Eda Akyürek Şahin, who has permitted me to publish these inscriptions, as also to Enver Sağır, the director of Bursa Archaeological Museum and to the archaeologist Koncağül Hançer for their support and collaboration in this work.

<sup>1</sup> These sarcophagi were noticed by the building workers who intended to construct an apartment precisely in this place: Osmaniye Mah. Yeşildağ Sk. 5. 01 pafta, 797 ada, 28 parsel. After rescue work was completed, these sarcophagi were moved into the garden of the Directorate of Technical Works in Gemlik where they stand today.

<sup>2</sup> For the city of Kios, see RE XI 1 col. 486–488; Cramer, *Asia Minor* 174–176; Perrot et al., *Exploration* 12; Ehrhardt, *Milet* 47–49; Bondoux 2003, 391–392; Avram 2004, 982–983. The inscriptions of the city have already been collected by T. Corsten, see *IKios*. See also Corsten 1991, 90–97 nos. 4–8; Tanrıver 1994, 119–120.

tion on the lid. It is worth mentioning that a gold coin from the time of Valerianus I and an intaglio carrying a depiction of Isis and Sarapis were found inside these sarcophagi, in addition to many skeletons and other small objects including a ring, a bone pin, a pair of dice, a jar, pendant and weight, showing these sarcophagi had not been opened and the contents robbed. These grave goods indicate that the deceased would need these possessions in their life to come or they were placed in these tombs as grave gifts. Three more soundings were taken in order to determine if any further sarcophagi existed in the excavation area. Even though remains of a wall were uncovered at the first sounding taken on the west side of the first sarcophagus, work ceased due to the absence of archaeological finds from the other two soundings.<sup>3</sup>

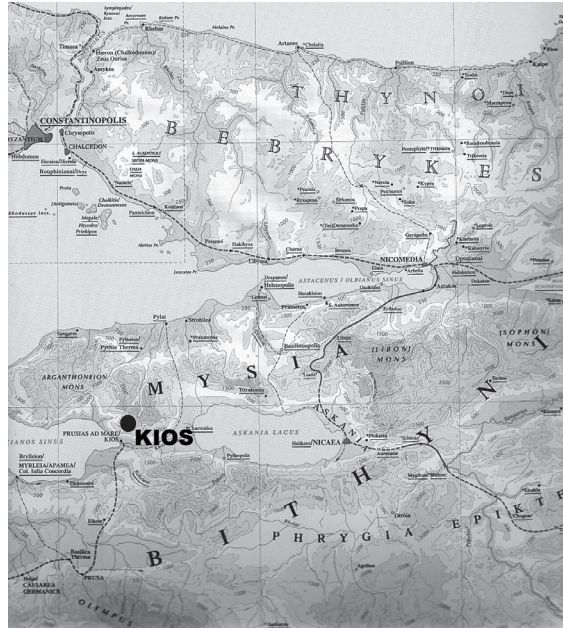

Fig. 1. Kios and its surroundings (Barrington Atlas, Map 52).

To date no systematic research has been conducted in the Bithynian city of Kios, located at the head of the Gulf of Gemlik, which functioned as the port of Nikaia. It was founded by Milesians as an emporium<sup>4</sup> in ca. 626/5 B. C. and was an important settlement in Classical, Hellenistic and Roman imperial times. However, not many remains have survived to the present day from this city; only parts of the acropolis and necropolis areas and some parts of the city walls are visible today.<sup>5</sup> To date three necropoleis belonging to Kios and its territory have been reported.<sup>6</sup> The first lies 2–3 km east of Gemlik, on the road to Nikaia<sup>7</sup>; the second is thought to be around Küçükçukur mevki,

<sup>3</sup> However, these three sarcophagi arranged in linear manner suggest the existence of a wide necropolis area lying beneath the modern buildings.

<sup>4</sup> Plin. *Nat. Hist.* V. 144: Postea sinus in quo flumen Ascanium, oppidum Bryalium, amnes Hylas et Cios cum oppido eiusdem nominis, quod fuit emporium non procul accolentis Phrygiae, a Milesiis quidem conditum, in loco tamen qui Ascania Phrygiae vocabatur... For the emporia of Asia Minor, see; INikaia II 1071; Robert, *A travers l'Asie Mineure* 74–76; Ruffing 2006, 123–150.

<sup>5</sup> Texier, *Asie Mineure* 112–113; Perrot et al., *Exploration* 12; RE XI 1 col. 487.

<sup>6</sup> For the necropoleis of Kios, see IKios, p. 11–13.

<sup>7</sup> Corsten (IKios, p. 13) reports that ca. 15 m. of this road could be seen behind the modern town in the direction of Nikaia. This road leading to Kios from the direction of Nikaia following the south shore of Lake Askania is mentioned by S. Şahin (INikaia II 1, p. 50) and is apparently connected to Apameia Myrleia and Prusa ad Olym-

which is ca. 2.5 km southwest of Gemlik on the road to Bursa<sup>8</sup>. On the basis of oral reports from the residents and city mayor, T. Corsten conjectures upon another necropolis located to the north of the city, in the direction of the village of Küçükkumla, though he indicates that precise information is missing and this area might have been engulfed by the sea.



Fig. 2. The sarcophagi in the course of their excavation.

It is well known that the region of Bithynia is very rich in respect to sarcophagi<sup>9</sup>, but this is not the case for Kios. Corsten reports<sup>10</sup> only two sarcophagi (one inscribed, the other uninscribed) and two cinerary chests preserved in the first necropolis area of Kios; one prefabricated garland sarcophagus belonging to Aur. Theodosius Rufus and his family<sup>11</sup> in the second area and one chamber room<sup>12</sup> close to this same area. The stylistic and iconographic features of this group of sarcophagi closely resemble each other. They all comprise a rectangular chest and a lid. The long sides of the chests are decorated with *tabulae ansatae*, in which Greek funerary inscriptions are carved. None of the chests have other decoration or ornament. The lids are in the form of a pitched roof with cornered acroteria and pediments. In Kios and its territory, not many sarcophagi are known to us<sup>13</sup> as mentioned above. Most of them were quite simple and this has led Corsten to comment that the east necropo-

---

pum. For the milestones which establish these connections, see INikaia II 13; IKios 14; French 1981, 150; 21; AE 2003 1650. For the detailed road system of the region, see INikaia II 1, p. 50–66; Marek, Pontus 56–59 Map V.

<sup>8</sup> IKios, p. 12.

<sup>9</sup> Akyürek Şahin 2011, 353. As she rightly observes, more detailed research is required on the Bithynian cinerary chests and sarcophagi in respect to their typology and iconography. For general information concerning the sarcophagi of Bithynia, see Dörner, Bithynien 20–26; Koch – Sichtermann, Sarkophag 509–514 Fig. 494–498; Koch, Sarkophag 169–171 Fig. 98; Koch, Lahitler 20–21 Fig. 32–36.

<sup>10</sup> IKios, p. 11–12.

<sup>11</sup> IKios 39.

<sup>12</sup> For a detailed description of this chamber room, see Mansel 1974, 181–189.

<sup>13</sup> Apart from the prefabricated garland sarcophagus cited above, some garland chests and lids of sarcophagi from the IV./V. century A. D. are known to have been destroyed after an illegal excavation at the road junction of Ulubey, a small town ca. 3 km south–west of Gemlik, see Yalman 1993, 362–363 Fig. 2–3. They are likely to have belonged to the south–west necropolis given their proximity to this area.

lis, where these sarcophagi were found, must have been for the lower-classes of the society.<sup>14</sup>

### 1. Grave of Rascanius Longinus and Flavianus Arkesilaos (figs. 3–11)

Marble sarcophagus. H: 140 cm (chest), 93 cm (lid); W: 254 cm (chest), 261 cm (lid); D: 144 cm (chest), 157 cm (lid); LH: 3,5 – 4 cm; Inv. no.: Gemlik 2009/1<sup>15</sup>

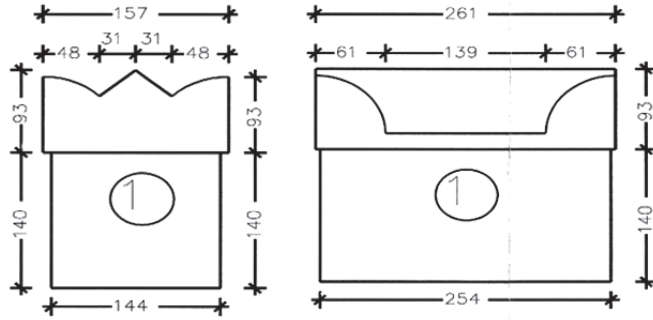

Fig. 3. Drawings of sarcophagus 1.

The sarcophagus consists of a chest and a roof-shaped lid, which has acroteria on all four corners and pediments. The lid has some small chips and cracks on the acroteria and pediment, and some scratches to the surface. The chest does not have feet and its surface is smoothly finished. On the long side of the chest there is a rectangular *tabula ansata*<sup>16</sup>, carrying an inscription of eleven carefully carved and neatly designed lines.



Fig. 4. Frontal view of sarcophagus 1.

<sup>14</sup> IKios, p. 12. Since this type of undecorated sarcophagi is typical for the region of Bithynia, it is quite difficult to justify this comment. In addition, it is highly probable that this recently unearthed cemetery area extended as far as the east necropolis on the road to Nikaia. That a city councillor and some other Roman citizens built tombs for themselves and their family members (see nos. 1–3) is another argument against this opinion.

<sup>15</sup> The sarcophagi have not been given permanent inventory numbers as yet.

<sup>16</sup> For the classification of the *tabula ansata* types of Asia Minor, see Asgari – Fıratlı 1978, 37–38. It is interesting that type 3 closely resembles our three sarcophagi, although interestingly they mention that this type has mostly the features of those found in southwest and inland Asia Minor. Cf. Rodenwalt 1942, 218–219; Koch, Sarcophagi 169–170.



- Ῥασκανία Σατουρνεῖνα Ῥασκα-  
 2 νίῳ Λογγεῖνῳ τῷ ἑαυτῆς πα-  
 τρὶ καὶ Φλαουιανῷ Ἀρκεσι- ρ  
 4 λάῳ τῷ ἑξαδέλφῳ καὶ ἐκ  
 παρθενεῖας ἀνδρὶ γενομέ-  
 6 νῳ τὸ σκεῦδος ἔθηκα· ὅς δ' ἂν  
 ἕτερον ἐπιβαλῆ, δώσει προσ-  
 8 τεῖμου τῷ ἱερωτάτῳ ταμείῳ  
 Ϟ ,ε χωρὶς εἰ μὴ τι ὁ υἱός μου ρ  
 10 Φλαουιανὸς Λογγεῖνος αὐτὸς  
 ἐθελήσει τεθῆναι πρὸς αὐτούς.



*“I, Rascania Saturnina, set up this container (sarcophagus) for my own father Rascanius Longinus and my cousin and husband Flavianus Arkesilaos from virginity. Whoever puts another body (into it), will pay to the most sacred treasury 5,000 denarii as punishment, except that if my son Flavianus Longinus himself wishes to be buried by them.”*

L. 1–2: The Latin names Rascania and Rascanius, of Etruscan origin, are not widely found in inscriptions, but they have already been documented on a stele found in the Bithynian city of Apameia–Myrleia, see IApameia 22 = AE 1991, 1463. Cf. Schulze, Eigennamen 92; 113; 396.

L. 4: Another instance of marriage between cousins is known in the genealogical inscription of the Licinnii, see IGR III 500, col. II 9–10 and 42. Cf. Adak 1996, 136–137.

Date: Presumably from the late 2<sup>nd</sup> or early 3<sup>rd</sup> century A. D. from the style of lettering employed and the high penalty recorded in l. 9. Thus it can be concluded that this tomb was re-used, either by the next generation of the family or it was exposed to violation, since it contained seven skeletons instead of three and the coin found inside the sarcophagus dates to the reign of Valerianus I (see below).

The genealogy of this family must be as follows:

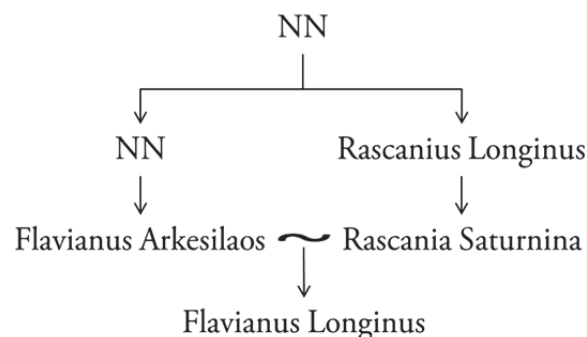

L. 4–5: It is understood that Rascania Saturnina was virgin when she married her husband Flavianus Arkesilasos and it is emphasized she remained married to her husband until his death. In his *Onomasticon* (3.39), the Graeco–Roman rhetorician Julius Pollux terms these women *πρωτόποσις*. Cf. LSJ. The expression ἐκ παρθενεῖας seen also as ἀπὸ παρθενεῖας, is not commonly found in inscrip-

tions. It has been attested in Pompeiopolis, a city in Paphlagonia, see Marek, Stadt 145, no. 31. Also cf. TAM II, 1 328; SEG 32, 612; Syll.<sup>3</sup> 983.

Small objects found inside the sarcophagus:

### 1.1. Gold coin<sup>17</sup> (fig. 5)

Aur.; Valerianus I (A. D. 253 – 260)

Wt: 2,60 g; Diam.: 0,21 cm; Inv. no.: 2009/462.

Obverse: IMP. C. P. LIC. VALERIANVS P. F.

AVG = Bust of the emperor facing right.

Reverse: FELICITAS AVGG=Felicitas standing left, holding long caduceus and cornucopiae.<sup>18</sup>

In RIC V 1, (p. 32) it is asserted that the titles “Pi-

us and Felix” were not used until A. D. 255 by either Valerianus I himself or his son and joint emperor Gallienus. Taking this into account, we can date this coin, and accordingly some of the burials in this sarcophagus to between A. D. 255 and 260, since the inscription “Augustorum” on the reverse side of coin makes it clear that Valerianus was still alive when it was minted.<sup>19</sup> After the death of Valerianus, the title Augustus on the coins consequently changed to AVG instead of AVGG.<sup>20</sup>



Fig. 5

### 1.2. Terracotta jar (fig. 6)

Mouth Diam.: 4 cm; Basis Diam: 2,9 cm; Shaft Diam: 13 cm; Inv. no.: 2009/173.

Jar with single handle; high base; circular mouth; spheroid shaft; cylindrical neck; made of red clay. From the neck down to the basis is covered with thick wheel made ridges.



Fig. 6

### 1.3. Bone Hair Pin (fig. 7)

H: 6,8 cm; D: 0,4 – 0,6 cm; Inv. no: 2009/174.

Consisting of a shaft and an ovoid-conical head. Beneath the head lies a reel. The shaft narrows towards the tip, and the end of the pin has been broken and is missing.



Fig. 7

<sup>17</sup> The actual dimension of the coin is not reproduced in this photograph.

<sup>18</sup> There are other examples of these types of coins carrying the same depictions on both faces minted in both Rome and Asia Minor, see RIC V 1 no. 34 and 282.

<sup>19</sup> Valerianus I and his son Gallienus were co-emperors from A. D. 253 to 260 until the death of Valerianus I, who was defeated at the battle of Edessa in A. D. 258 and was taken prisoner by the Persian king Shapur I. For the details of his humiliation and death, see Lact. *Mor. Pers.* V.

<sup>20</sup> RIC V 1, p. 33. Corsten (IKios, p. 44) claims that the mint in Kios ended in the 2<sup>nd</sup> half of 3<sup>rd</sup> century because of the general imperial ban on local coin minting for the cities of Asia Minor and due to the attacks of the Goths. The last known coin from Kios was minted in the reign of emperors Gallienus and his son Salonius. Cf. Waddington et al., *Asie Mineure* 331–332.

1.4. Beads (fig. 8)

The beads are of differing dimensions and probably once formed a necklace.



Fig. 8

2. The Grave of Kladaios and Iulius Harmodios (figs. 9–17)

Marble sarcophagus. H: 90 cm (chest), 60 cm (lid); W: 214 cm (chest), 230 cm (lid); D: 95 cm (chest), 109 cm (lid); LH: 1,5 – 2 cm; Inv. no.: Gemlik 2009/2.

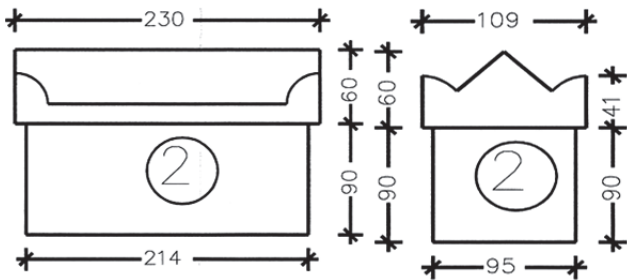

Fig. 9. Drawings of sarcophagus 2.



Fig. 10. The finds inside the chest

The sarcophagus consists of a chest and a roof-shaped lid which has acroteria at all four corners and pediments. Some small scratches and breaks are observable. The chest, of rectangular form, has no feet, its surface was smoothed and it contained seven skeletons. Along all four sides of the chest there is a horizontal scratch. On the long side of the lid is a tabula ansata, in which an inscription of two lines was carved.

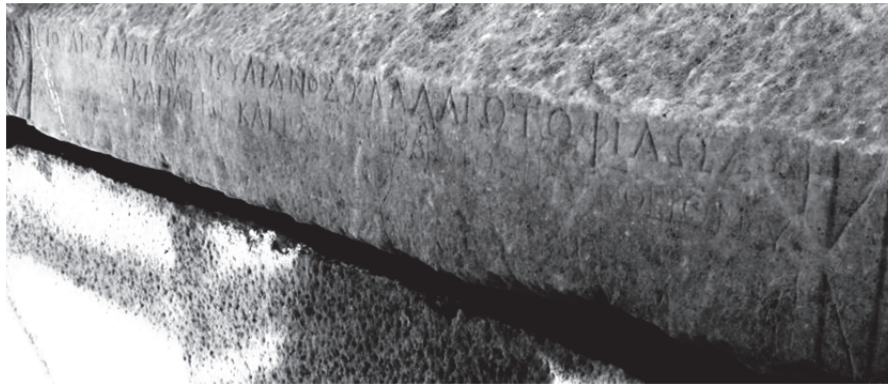

Fig. 11. The inscription on the sarcophagus lid.

M(ἄρκος) Ἰούλιος Αἰλιανὸς Ἰουλιανὸς Κλαδαίω τῷ φίλῳ ϐ  
 2 ϐ καὶ ἰατρῷ καὶ Ἰουλίῳ Ἄρμωδίῳ τῷ ἀπελευθέρῳ μου.

*“I, Marcus Iulius Aelianus Iulianus, (made this sarcophagus) for Kladaios, my friend and physician and for Iulius Harmodios, my freedman.”*

L. 1: For the name of Kladaios, see LGPN VA 246.

L. 2: Physicians were often chosen from amongst the slaves or freedmen in the Roman world, and

they were also considered as friends amongst the Romans, see CIL XIV 3030 = ILS II, 2 7788. Cf. Scarborough 1970, 299. M. Iulius Aelianus Iulianus apparently constructed this tomb for his slaves. Considering the fact that Iulius Harmodios's social status – of a freedman – was emphasized, while that of Kladaios was not, it can be inferred that Kladaios remained a slave. For another instance of a *servus medicus* attested as friend of a free citizen, see Prakken 1954, 321= AE 1955, 1. Cf. Kudlien, *Stellung des Arztes* 101 and 117.

Date: The style of lettering employed indicates a late 2<sup>nd</sup> or early 3<sup>rd</sup> century A. D.

The small objects found inside the sarcophagus:

### 2.1. Intaglio of Isis and Sarapis<sup>21</sup> (fig. 12)

W: 1,2 cm; D: 3 cm; H: 1,4 cm; Inv. no.: 2009/178.

The intaglio is made of red carnelian and on its face depicts two busts (one male and one female) in profile, side by side and facing left. The bearded male figure is apparently the god Sarapis from the kalathos on his head, and the female head is Isis, depicted wearing her crown with horns.<sup>22</sup> On the left-bottom of the intaglio is carved a sistrum (rattle), another of the important attributes of Isis.



Fig. 12

### 2.2. Gold Pendant (fig. 13)

H: 1,5 cm; Wt: 0,94 g; Diam: 0,8 mm; Inv. no.: 2009/179.

This pendant from a necklace has a soldered loop on its upper part, through which the string of the necklace passed. The pendant has the form of a globular vase decorated with flutes with a pointed base ending in a ball.



Fig. 13

### 2.3. A pair of gold earrings (fig. 14)

H: 1,1–1,3 cm; Wt: 0,175 – 0,331 g; Inv. no.: 2009/177.

These earrings are circular hoops consisting of spirally twisted wires, one is forming a loop ending in three coils (two coils end the other earring). The pendant is partially missing from one of these earrings.



Fig. 14

<sup>21</sup> For epigraphical evidence of the cult of Isis and Sarapis in Bithynia, see IPrusa ad Olympum I 48. For Anubis in Kios, see IKios 21 (= Merkelbach – Stauber, *Steinepigramme II* 135–136 no. 09/01/02); Also cf. IKios 22 and 23.

<sup>22</sup> We have been able to find precise parallels for these intaglios in respect to both iconography and style, see LIMC V 1 nos. 136; 138; 145; 148; LIMC VII 1 col. 680 no. 131a.; Zwierlein-Diehl, *Gemmen*, no. 203. For other depictions of Isis and Serapis, see LIMC V I col. 771–773 nos. 130–162; LIMC VII 1 nos. 121–148; Spier, *Gems*, no. 336. In Asia Minor, two similar depictions of Isis carved on intaglios are documented, see Konuk – Arslan, *Gems* 116–118 nos. 93–94. In her unpublished MA thesis, Uygun introduces another similar type of ring and intaglio from Patara, on which Isis is depicted which dates from the second half of the second century B. C., see Uygun, *Takılar* 40–43 Fig. 9 a–b (Y10). Cf. Hornbostel, *Sarapis* 161–167; Boardman – Scarisbrick, *Finger Rings* 32 no. 45.



## 2.4. 15 pieces of game stones (fig. 15)

Diam: 2,5x2,4 – 2,3x2,2 cm; D: 0,7–0,6 cm; Inv. no. 2009/176.

The stones, which are round and made of glass, have different dimensions and on their surfaces are seen colours such as green, blue and beige. During conservation, nine of these stones which were broken were joined back together again by the museum staff.

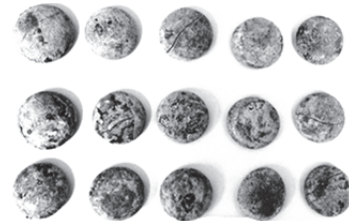

Fig. 15

## 2.5. A pair of bone dice (fig. 16)

Diam. (1): 0,6–8,8 mm; Diam. (2): 0,7–0,8 mm; Inv. no. 2009/175.

These brown bone dice are of typical Roman style, namely they are of cubic shape and are indicated by dots numbered from 1 to 6 and, as is typical of this type of Roman dice, when the dots on the uppermost face are added to those on the lowermost face, seven is always the sum of these two faces.<sup>23</sup>



Fig. 16

## 2.6. Marble weight (?) (fig. 17)

H: 7,2 cm; W: 12 cm; D: 0,7 cm; Wt.: 148,8 gr; Inv. no. 2009/180.

A thin tablet of polished green marble which may have been used as a weight.

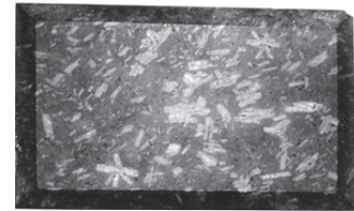

Fig. 17

## 3. Grave of Aurelius Numerius and his children (fig. 18–24)

Marble sarcophagus. H: 115 cm (chest), 66 cm (lid); W: 254 cm (chest), 270 cm (lid); D: 135 cm (chest), 144 cm (lid). LH: 2,8 – 3 cm; Inv. no.: Gemlik 2009/3.

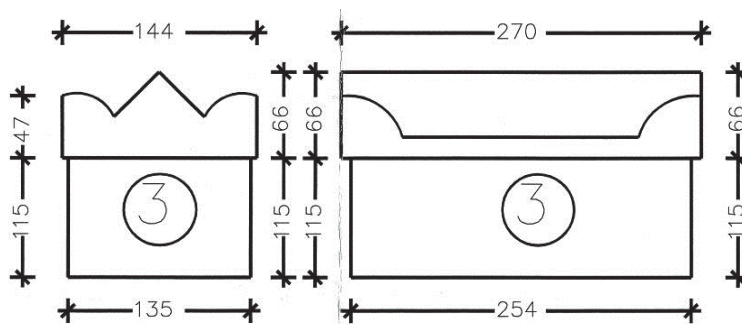
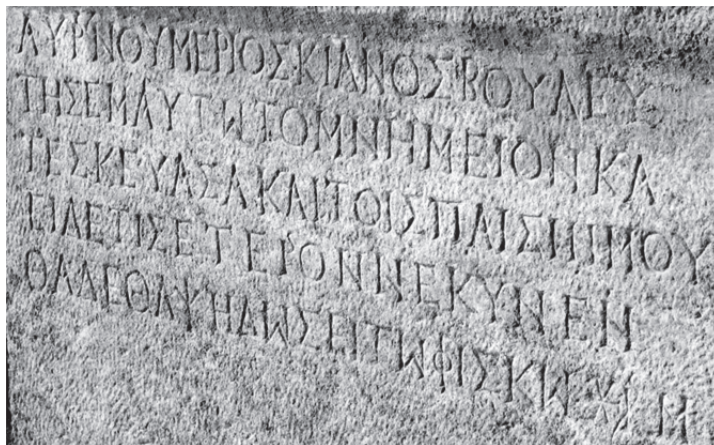

Fig. 18. Drawings of the Sarcophagus 3.

The sarcophagus consists of a rectangular chest a roof-shaped lid with four acroteria and pediments closely resemble nos. 1 and 2. Traces of mortar remain visible at the intersection of the lid and the chest. Both chest and lid are generally well preserved, except for some small cracks. The chest contained seven

skeletons as was the case with the other sarcophagi described above (nos. 1–2). On the front side of the chest there is a tabula ansata containing a neatly carved Greek inscription of five lines.

<sup>23</sup> For detailed information concerning dice and games with dice, see Rieche, *Gesellschaftsspiele* 16–17; Ineichen, *Würfel* 40–61. Cf. Backe-Dahme, *Kinder* 48–56.

*Fig. 19. Sarcophagus 3.**Fig. 20. The Inscription on the sarcophagus.**Fig. 21. Detail from the inscription.*

- Αὐρ(ήλιος) Νουμέριος Κιανὸς βουλευ-  
 2 τῆς ἑμαυτῶ τὸ μνημεῖον κα-  
 τεσκεύασα καὶ τοῖς παισίν μου·  
 4 Εἰ δέ τις ἕτερον νέκυν ἐν-  
 θάδε θάψη, δώσει τῶ φύσκῳ Ἣ ιμ'.

*“I, Aurelius Numerius, the citizen of Kios, the councillor, built this tomb for myself and my own children. If anyone buries another corpse, they will pay to the fiscus 100,000 denarii.”*

L. 1: Aurelius Numerius: No councillor has been attested in the inscriptions of Kios to date, and likewise to our knowledge, no other Numerius has been documented in Bithynia, however this name is known from some other inscriptions in Asia Minor, see ISmyrna I 198; 234; 704; IEphesos VI 2256. 1; IEphesos V 1573; SEG XIX 847; Körte 1899, p. 3.

L. 4: For a very similar statement, see IKios 77. Cf. TAM IV 249.

L. 5: δηναρῖων δέκα μυριάδας. A fine of a similar amount is attested in the Pisidian city of Termessos, see TAM III 318. Cf. IKyzikos I 49, 113 and 109. The reason for this astronomical amount might relate to the financial crisis of the age when this inscription was carved. In addition, Cormack specifies some other possible reasons for such high penalties, see Cormack, Death 130–131. In Kios itself there is recorded a funerary inscription, which has a penalty of 120, 000 denaria, but it accords with 20 *solidi*, dating this inscription to the fourth century A. D. as Corsten rightly points out.<sup>24</sup>

Date: After A. D. 212 on account of the name Aurelius and the high penalty amount mentioned in l. 5.

Small objects found inside the sarcophagus:

### 3.1. Gold ring (fig. 22)

Wt: 2,896 g; Diam: 1,6 cm; Inv. no.: 2009/181.

It is composed of seven elliptic rings attached to each other. Inside the circles were placed blue-coloured glass beads, one of them is missing.



Fig. 22

### 3.2. A pair of golden earrings (fig. 23)

Wt: 1,26 g; Diam.: 1,4 cm; D: 0,1 cm (for both of them); Inv. no. 2009/182.

This pair of earrings consists each of a hollow ring, the ends of which are connected by twisting one around the other.



Fig. 23

### 3.3. Spindle whorl (fig. 24)

H: 0,9 cm; Diam.: 2,3 cm; Inv. no: 2009/183.

This whorl made of green glass, is of a circular shape with a central hole. Its function was to spin the thread.

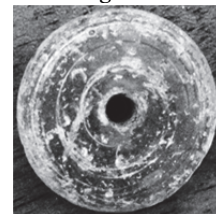

Fig. 24

<sup>24</sup> IKios 77. Cf. IParion 44.

## Abbreviated Literature

- Akyürek Şahin 2011 N. E. Akyürek Şahin, Nikomedeia'dan İki Entelektüel: Basilikos ve Kyrion'un Mezar Epigramları, *Olba XIX*, 2011, 349–370.
- Adak 1996 M. Adak, Claudia Anassa– eine Wohltäterin aus Patara, *EA 27*, 1996, 127–142.
- Asgari – Fıratlı 1978 N. Asgari – N. Fıratlı, Die Nekropole von Kalchedon, in: S. Şahin – E. Schwertheim – J. Wagner (ed.), *Studien zur Religion und Kultur Kleinasiens. Festschrift für F. K. Dörner zum 65. Geburtstag*, Leiden 1978, 1–107.
- Avram 2004 A. Avram, The Propontic Coast of Asia Minor, in: M. H. Hansen – T. H. Nielsen (ed.), *An inventory of Archaic and Classical Poleis*, Oxford 2004, 974–999.
- Backe-Dahmen, Kinder A. Backe-Dahmen, *Die Welt der Kinder in der Antike*, Mainz 2008.
- Boardman – Scarisbrick, Finger Rings J. Boardman – D. Scarisbrick, *The Ralph Harari Collection of Finger Rings*, London 1977.
- Bondoux 2003 R. Bondoux, Les Villes, in: B. Geyer – J. Lefort (ed.), *La Bithynie au Moyen Âge (Réalités Byzantines 9)*, Paris 2003, 377–409.
- Cormack, Death S. Cormack, *The Space of Death in Roman Asia Minor*, Vienna 2004.
- Corsten 1991 T. Corsten, *Neue Denkmäler aus Bithynien*, *EA 17*, 1991, 79–100.
- Cramer, Asia Minor J. A. Cramer, *A geographical and historical description of Asia Minor with a map*, Oxford 1832.
- Dörner, Bithynien F. K. Dörner, *Inschriften und Denkmäler aus Bithynien*, *IstForsch 14*, Berlin 1941.
- Ehrhardt, Milet N. Ehrhardt, *Milet und seine Kolonien. Vergleichende Untersuchung der kultischen und politischen Einrichtungen*, Frankfurt am Main 1983.
- French 1981 D. French, Milestones of Pontus, Galatia, Phrygia, and Lycia, *ZPE 43*, 1981, 149–174.
- Higgins, Jewellery R. Higgins, *Greek and Roman Jewellery*, London 1980.
- Hornbostel, Sarapis W. Hornbostel, *Sarapis. Studien zur Überlieferungsgeschichte, den Erscheinungsformen und Wandlungen der Gestalt eines Gottes*, *EPRO 32*, Leiden 1973.
- Ineichen, Würfel R. Ineichen, *Würfel und Wahrscheinlichkeit. Stochastisches Denken in der Antike*, Heidelberg–Berlin–Oxford 1996.
- Koch – Sichtermann, Sarkophage G. Koch – H. Sichtermann, *Römische Sarkophage*, München 1982.
- Koch, Sarkophage G. Koch, *Sarkophage der römischen Kaiserzeit*, Darmstadt 1993.
- Koch, Lahitler G. Koch, *Türkiye'deki Roma İmparatorluk Dönemi Lahitleri / Sarkophage der Römischen Kaiserzeit in der Türkei*, Antalya 2010.
- Körte 1899 A. Körte, *Kleinasiatische Studien IV. Ein Altphrygischer Tumulus bei Bos-öyük(Lamunia)*, *AM 24*, 1899, 1–46.
- Konuk – Arslan, Gems K. Konuk – M. Arslan, *Ancient Gems and Finger Rings from Asia Minor. The Yüksel Erimtan Collection*, Ankara 2000.
- Kudlien, Stellung des Arztes F. Kudlien, *Die Stellung des Arztes in der römischen Gesellschaft*, Stuttgart 1986.
- LGPN VA T. Corsten, *A Lexicon of Greek Personal Names V A. Coastal Asia Minor: Pontos to Ionia*, Oxford 2010.
- Mansel 1974 A. M. Mansel, *Gemlik Tümülüs Mezarı*, *Belleten 38 (150)*, 1974, 181–189.
- Marek, Stadt C. Marek, *Stadt, Ära und Territorium in Pontus–Bithynia und Nord–Galatia*, Tübingen 1993 (*IstForsch 39*).
- Marek, Pontus C. Marek, *Pontus et Bithynia. Die römischen Provinzen im Norden*



- Kleinasien, Mainz am Rhein 2003.
- Merkelbach – Stauber, Steinepigramme II R. Merkelbach – J. Stauber, Steinepigramme aus dem griechischen Osten II. Die Nordküste Kleinasien (Marmarameer und Pontos), München–Leipzig 2001.
- Perrot et al., Exploration G. Perrot – E. Guillaume – J. Delbet, Exploration archéologique de la Galatie et de la Bithynie, d'une partie de la Mysie, de la Phrygie, de la Cappadoce et du Pont, Paris 1872.
- Prakken 1954 D. W. Prakken, Funerary Inscriptions in New York, AJA 58.4, 1954, 321–322.
- Rieche, Gesellschaftspiele A. Rieche, Römische Kinder- und Gesellschaftspiele, Stuttgart 1984.
- Robert, A travers l'Asie Mineure L. Robert, A travers l'Asie Mineure. Poètes et prosateurs, monnaies grecques, voyageurs et géographie, Paris 1980.
- Rodenwalt 1942 G. Rodenwaldt, Ein Typus römischer Sarkophage, BJB 147, 1942, 217–228.
- Ruffing 2006 K. Ruffing, Städtische Wirtschaftspolitik im hellenistisch-römischen Kleinasien? Zur Funktion der Emporia, in: H. U. Wiemer (ed.), Staatlichkeit und politisches Handeln in der römischen Kaiserzeit, Berlin 2006, 123–151.
- Scarborough 1970 J. Scarborough, Romans and Physicians, CJ 65, 1970, 296–306.
- Schulze, Eigennamen W. Schulze, Zur Geschichte lateinischer Eigennamen, Berlin 1904.
- Spier, Gems J. Spier, Ancient Gems and Finger Rings: Catalogue of the collections / The J. Paul Getty Museum, California 1992.
- Tanrıver 1994 C. Tanrıver, Kios'tan iki yeni mezar steli, in: H. Malay (ed.), M. (Usman) Anabolu'ya Armağan: Presented to M. (Usman) Anabolu, Arkeoloji Dergisi II, 1994, 119–120.
- Texier, Asie Mineure C. Texier, Asie Mineure: Description géographique, historique et archéologique des provinces et de villes de la Chersonnèse d'Asie, Paris 1862.
- Uygun, Takılar Ç. Uygun, Patara Geç Hellenistik – Roma Dönemi Takıları, Antalya 2000 (Unpublished Master Thesis).
- Yalman 1993 B. Yalman, İznik ve Çevresinde Belirlenen Eski Eser Tahribatları ve Önere Koruma Tedbirleri, A. Ü. Dil Tarih Coğrafya Fakültesi Dergisi, 36, 1.2, 1993, 461–479.
- Waddington et al., Asie Mineure W. H. Waddington – E. Babelon – T. Reinach, Recueil Général des Monnaies Grecques d'Asie Mineure, Paris 1908.
- Zwierlein-Diehl, Gemmen E. Zwierlein-Diehl, Die antiken Gemmen des Kunsthistorischen Museums in Wien Band 1. Die Gemmen von der minoischen Zeit bis zur frühen römischen Kaiserzeit, München 1973.

## Özet

### Kios'dan (Gemlik) Üç Yeni Lahit

Bu makalede, 2009 yılında Bursa'nın Gemlik (antik Kios kenti) ilçesinde bir inşaat yapımı sırasında fark edilen ve Bursa Arkeoloji Müze Müdürlüğü tarafından yapılan kurtarma kazıları sonucu gün yüzüne çıkarılan Roma İmparatorluk Dönemine ait üç lahit ve lahitlere mezar armağanları olarak konulan küçük objeler tanıtılmaktadır. İkonografik ve stilistik açıdan birbirlerine benzeyen lahitler üzerinde herhangi bir kabartma ya da bezeme bulunmamaktadır. İki tekne üzerinde, diğeri ise kapığın yan uzun yüzünde bulunan tabula ansalarda özenle yazılmış Yunanca mezar yazıtları mevcuttur. İlk lahit içerisinde ele geçen buluntular arasında imparator Valerianus I ve ortak imparator Gallienus devrine ait altın bir sikke dikkat çekmektedir. Marcus Iulius Aelianus Iulianus tarafından

doktoru ve azatlı kölesi için yaptırılan ikinci lahitten çıkartılan bir yüzük kaşı üzerinde Isis ve Serapis büstleri bulunmaktadır. Üçüncü lahdi kendisi ve ailesi için yaptıran Aurelius Numerius, Kios kentinden şu ana kadar bilinen ilk meclis üyesi olma özelliğini taşımaktadır. Bu lahde yapılacak başka bir gömü için belirlenen cezanın 100,000 dinar gibi yüksek bir meblağ olması yazıtlarda sıkça görülen bir durum değildir. Yazıtların çevirileri ise şöyledir:

1. Lahit = Rascanius Longinus ve Flavianus Arkesilaos'un mezarı:

*“Ben, Rascania Saturneina, babam Rascanius Longinus için, kuzenim ve genç kızlığımdan (bakireliğimden) kocam olan Flavianus Arkesilaos'a bu lahdi yaptırdım. Eğer birisi buraya başka bir (cesedi) gömersen, kutsal kasaya ağırlaştırılmış (ceza olan) beş bin denaria verecektir! Ve oğlum Flavianus Longinus bunun dışında kalacak ve (eğer) kendisi isterse onların yanına gömülebilecektir!”*

2. Lahit = Doktor Kladaios'un ve azat edilmiş kişi Iulius Harmodios'un Mezarı:

*“Ben, M(arcus) Iulius Aelianus Iulianus, hekim dostum Kladaios ve azatlım Iulius Harmodios için (bu mezarı yaptırdım).”*

3. Lahit = Kioslu Aurelius Numerius ve çocuklarının mezarı:

*“Ben, Kioslu meclis üyesi Aurelius Numerius bu mezarı kendim ve çocuklarım için yaptırdım. Eğer birisi buraya başka bir cesedi gömecek olursa, kent kasasına 100,000 denaria verecektir (ceza ödeyecektir)!”*

*Anahtar Sözcükler:* Bithynia; Kios; lahit; Gemlik; küçük objeler; Isis; Sarapis; yüzük kaşı; I. Valerianus; altın sikke.