

PERFORMANCE OF ROTATING BIOLOGICAL CONTACTORS OPERATING AT DIFFERENT TEMPERATURES

Ali BERKTAY

Selçuk University, Department of Environmental Engineering, Konya

ABSTRACT

An investigation was carried out to define the effects of temperature change on the biological wastewater treatment using a Rotating Biological Contactors (RBC). The major investigation was to establish the optimum operational conditions of the unit and to determine how its efficiency was affected by temperature. During the investigation, the substrate employed was a synthetic wastewater made up frequently in the laboratory. Experimental works were conducted at three constant temperature, 10 °C, 20 °C and 30 °C. There was a considerable increase in efficiency of the unit, measured by removal of organic material, between 10 °C and 20 °C, but much less of a change from 20 °C to 30 °C. These variations were reflected by the rate of formation of total oxidized nitrogen in the unit.

Key Words : Biological wastewater treatment, Rotating biological contactors, Temperature

DEĞİŞİK SICAKLIKLARDA İŞLETİLEN BİR BİYODİSK ÜNİTESİNİN PERFORMANSININ BELİRLENMESİ

ÖZET

Bu çalışma, bir biyodisk ünitesi kullanarak sıcaklık değişimlerinin biyolojik atıksu arıtımı üzerine etkisinin belirlenmesi için gerçekleştirilmiştir. Çalışmanın büyük çoğunluğunda biyodisk ünitesi için optimum işletim şartları belirlenmeye çalışılmış ve bu esnada ünite performansının sıcaklık değişimleri tarafından nasıl etkileneceği araştırılmıştır. Çalışmada atıksu kaynağı olarak laboratuvar şartlarında hazırlanmış sentetik atıksu kullanılmıştır. Deneysel çalışmalar üç değişik sıcaklıkta, 10 °C, 20 °C ve 30 °C'ta sürdürülmüştür. Sıcaklığın 10 °C ile 20 °C arasında değişmesi halinde organik madde gideriminde önemli miktarlarda artışlar olmasına rağmen sıcaklığın 20 °C ile 30 °C arasında değişmesi halinde çok fazla olmamıştır. Bu değişimler ünite içerisindeki toplam okside olmuş nitrojen oluşumunun ölçülmesi ile belirlenmiştir.

Anahtar Kelimeler : Biyolojik atıksu arıtımı, Biyodisk ünitesi, Sıcaklık

1. INTRODUCTION

Over the past years, an increasing interest has been shown in the development and application of Rotating Biological Contactors (RBC) as a means of treating wastewater, particularly those from small communities. The particular problems of wastewater treatment plants for small communities are related to such factors as lack of skilled supervision, variable

loading with hydraulic surges several times that of the average flow and a relatively strong sewage.

The RBC system is a secondary biological wastewater treatment process. In this process, a series of closely spaced discs are mounted on a horizontal shaft which continually rotates. The discs are partially submerged (approximately 40 %) in the wastewater and they are rotated at a speed of 1-10 rpm (Antonie, 1976). The design organic loading,

for domestic wastewater is about $6.0 \text{ g BOD}_5/\text{m}^2 \text{ day}$ (Pike, 1978; Strom and Chung, 1985). According to Metcalf and Eddy (1991), this parameter ranges from 7.35 to $14.5 \text{ g BOD}_5/\text{m}^2 \text{ day}$. Torpey and co-workers (1971) treated settled wastewater with a 10 stage, 0.9 m diameter RBC with an overall retention time of 1 hour. They achieved 93 % BOD_5 removal and 92 % suspended solids removal. Pike and co-workers (1982) reported on a long term experiment using a full-scale RBC treatment plant. With the organic loadings of 5.5 to $7.1 \text{ g BOD}_5/\text{m}^2 \text{ day}$, more than 90 % BOD_5 removal 82 % suspended solids removal together with 59 % ammoniacal nitrogen removal was achieved.

The performance of the system dealing with the BOD_5 removal was affected by the limitation of Dissolved Oxygen (DO) concentration during the summer. The system performance for the removal of ammoniacal nitrogen was affected by the rate of substrate removal in the earlier stages and by the pH levels (Hidlebaugh and Miller, 1981).

The total surface area required can simply be calculated by the design organic loading. The required surface area is translated into the number and size of the discs necessary. It is essential to consider the effect of temperature for design purposes for any RBC unit. Temperature correction can be made by using a temperature correction factor.

As with all biological processes, temperature can have an important effect on decay rate. Most of the experimental works were carried out at temperatures around $20 \text{ }^\circ\text{C}$ in the literature. When a full-scale RBC plant design is based on the essential controlling variables of influent, a scale-up factor should be considered. The process scale-up factor was found to increase from 1.067 at $3 \text{ }^\circ\text{C}$ to 1.227 at $25 \text{ }^\circ\text{C}$ (Wu and Smith, 1983). Correction factors have been developed for lower temperature operation (Ellis and Bannaga, 1976; Poon et al., 1981). Higher temperatures appear to have little effect on removal of BOD_5 , but may improve nitrification (Weng and Molof, 1974).

2. MATERIAL AND METHODS

In this investigation, a rotating biological disc unit consisted of 27 circular perspex discs was used. Each disc was 200 mm in diameter, 3 mm thickness and mounted on a single shaft. The total disc surface area was 1.7 m^2 . The unit was divided into 7 stages. Each stage held 4 discs except for the last one which

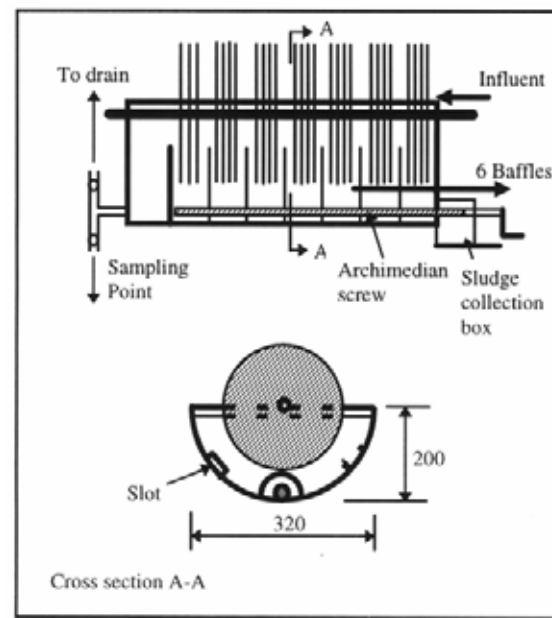

Figure 1. Experimental unit

held 3 discs. Each stage was separated from adjacent stages by using a slotted baffle which was designed to reduce short circuiting. The bottom of each of the baffles was also cut away to facilitate the passage of the sludge (Figure 1).

There was no final settlement tank so that the vessel was operated as a reaction vessel and a secondary clarifier in which settlement of the sludge was accomplished. The volume of the wastewater in each vessel was 19 liters. The volume of water in the unit was maintained by an overflow weir which was installed at the outlet end of the vessel. The unit was then operated at a constant disc submergence of 40 % at all times. The discs were rotated at a speed of 4 rpm.

The reaction tank for the rotating biological disk unit was constructed of a galvanized mild steel semicircular tube, 320 mm width, 200 mm height and 520 mm length with a wall thickness of 4 mm . An Archimedian screw was installed inside the unit. The settled sludge was then removed by this Archimedian screw and was collected in a box attached to the front of the reaction tank. The Archimedian screw was 30 mm in external diameter and was rotated manually by means of handle.

Samples taken from influent and effluent were tested for pH, Suspended Solids (SS), Biochemical Oxygen Demand (BOD_5) and Chemical Oxygen Demand (COD), Ammonia, Nitrite, Nitrate, Total Oxidized Nitrogen (TON) and Detergents. Synthetic wastewater was used throughout the investigation to simulate domestic wastewater. The use of synthetic

wastewater provided certain advantages i.e. having relatively uniform characteristics, having no toxic chemicals, and being prepared in laboratory at any time and to the strength desired. Synthetic wastewater prepared for the unit was stored in a storage tank for a period of between 2 to 4 days, depending on the quality required. The average composition of the inflow is shown in Table 1. In general, this synthetic wastewater possessed similar characteristics to that of settled domestic wastewater and had a sufficient nitrogen and phosphorus content for the unlimited growth of microbial populations.

It is of importance to have some knowledge of the amount of organic matter in the wastewater that can be biochemically oxidized. An indication of the degree of treatability of wastewater can be obtained from the BOD₅/COD ratio. For this synthetic wastewater the average ratio of BOD₅/COD was found to be 0.59. These values seem to be similar to those for a domestic wastewater as reported by Boon and Burgess (1972).

Table 1. The Average Strength of the Influent

Parameters	Range		Mean
	Min.	Max.	
Temperature (°C)	8.7	23.9	16.0
pH	7.1	7.9	7.5
Suspended Solids (mg/L)	53.0	229.0	105.0
Biochemical Oxygen Demand BOD ₅ , (mg/L)	82.0	292.0	200.0
Chemical Oxygen Demand COD, (mg/L)	182.0	509.0	335.0
Ammoniacal Nitrogen (mg/L)	20.4	47.3	32.9
Organic Nitrogen (mg/L)	11.2	31.5	17.8
Total Organic Carbon TOC, (mg/L)	36.0	80.0	60.5

3. EXPERIMENTAL RESULTS AND DISCUSSION

The RBC is a fixed film treatment device, essentially simple in design with a low power requirement. Besides the variables of hydraulic and organic loading, important factors affecting the efficiency of the process are the speed of rotation of the discs, their degree of immersion in the liquid and as with all biological processes, the temperature of operation. During the investigation all comparisons between results operating under different conditions were made when the steady state had been achieved. This steady state was defined as that time when the rate of removal of organic material and detergents had become constant as well as the rate of nitrification.

The investigation was divided into two principal sections. Initially the unit was operated for a

preliminary period to establish the general capabilities of the design, to gain reasonable experience in operating the unit and particularly to establish an optimum rotational speed for the discs. The major investigation was then to establish the optimum operational conditions of the unit and to determine how its efficiency was affected by temperature.

During the preliminary operations, the unit was operated at the ambient temperature and the liquid retention period in the reaction vessel during this phase was 4 hours and the water level was set so that 40 % of the disc surface was below liquid level. Disc rotational speeds of 2, 4, 5 and 10 rpm were investigated. Of the rotational speeds investigated it was found that the lowest speed of 2 rpm allowed excessive amounts of biological growth to develop on the discs with the possibility of its bridging between adjacent surfaces and therefore materially reducing the available disc area. At the highest speed of 10 rpm only a thin active slime remained on the surfaces of the discs but the turbulence produced in the reaction vessel by the high disc speed hindered the settlement of SS and caused the effluent to deteriorate. The results of this preliminary work indicated that a speed of disc rotation of about 4 rpm produced the best results for design and this speed was subsequently used for all the following operations.

During the major investigation, the unit was maintained in three constant temperature rooms at 10 °C, 20 °C and 30 °C at different time intervals and an attempt was made to discover an optimum liquid retention period. Due to cooling effect of evaporation, the actual reaction temperatures of the unit were 18 °C and 27 °C at higher temperatures. Also, difficulties in cooling the substrate meant that the reaction temperature of the unit at lower temperature was 11 °C at lower temperature.

Operating with a constant rotational speed of 4 rpm for the unit, hydraulic retention periods of 4 hours, 3 hours, 2.4 hours and 2 hours were investigated. Under these conditions and with a 3 h retention period for the unit operating at 20 °C and 30 °C and 4 h retention period for the unit operating at 10 °C, more than 90 % of the applied BOD₅ was removed (Figure 2). These liquid retention periods corresponded with a BOD₅ loading of 12.2 g BOD₅/m² and 9.1 g BOD₅/m², respectively. There was a considerable increase in efficiency of the unit, measured by removal of organic material, between 10 °C and 20 °C, but much less of a change from 20 °C to 30 °C. These variations were reflected by the rate of formation of total oxidized nitrogen in the unit.

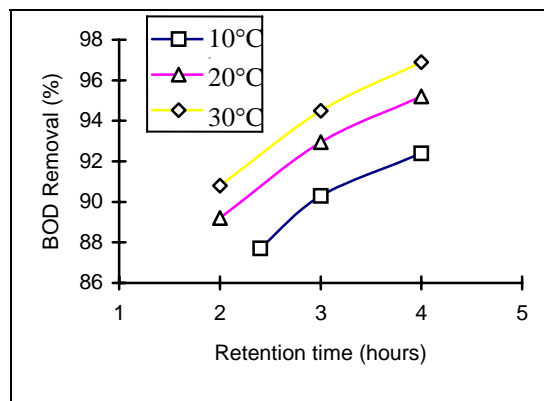

Figure 2. Variation of efficiency with retention time

At this time it was known that the optimum rotational speed of the discs was 4 rpm and the liquid retention period producing the maximum efficiency was 3 h for the unit operating at 20 °C and 30 °C and 4 h for the unit operating at 10 °C.

For three months operating at 4 rpm, the liquid retention period was consecutively reduced from 180 min to 132 min, to 97 min and to 60 min. As shown in Figure 3, with a retention period of 97 min, the percentage removal of BOD₅ for the unit was greater than 90 % with the unit operating at 30 °C being as high as 95 %. These percentages dropped significantly when the retention period was reduced to 60 min and with the same reduction the ability to nitrify nearly completely disappeared from the unit.

The variation of BOD₅ removal are shown in Figure 4 as a function of organic loading at three temperatures. During the investigation, nominal retention times of 180, 132, 97 and 60 min corresponded to organic loadings of 9.3, 11.0, 16.2 and 23.2 g BOD₅/m² day, respectively.

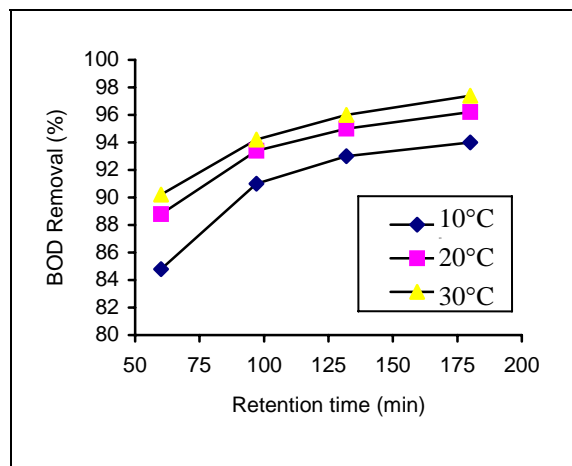

Figure 3. Variation of efficiency with retention time

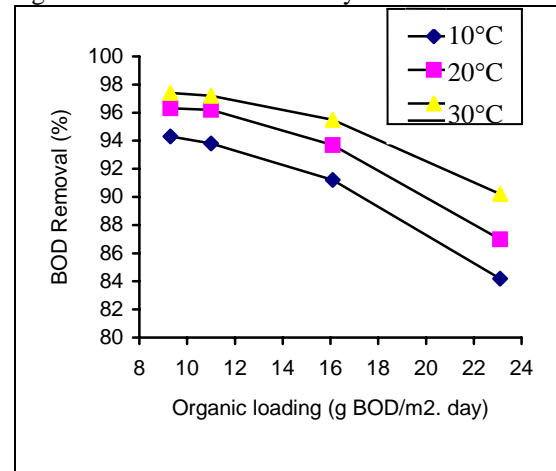

Figure 4. Variation of efficiency with loading

The literature review revealed that these applied organic loadings were appreciably greater than most recommended organic loadings.

Table 2. Effluent Quality (All Analytical Results Expressed in mg/L)

Temperature (°C)	Retention period (min)	BOD ₅	COD	SS	Detergents
10	180	9.5	44.0	10.0	0.8
	132	10.0	47.5	9.0	1.0
	97	17.0	65.0	14.0	1.3
	60	29.0	121.0	31.0	1.8
20	180	7.5	32.0	8.0	0.7
	132	8.0	35.0	8.0	0.7
	97	13.0	47.0	10.0	1.0
	60	22.0	107.0	23.0	1.4
30	180	6.5	26.0	8.0	0.5
	132	7.0	28.5	7.0	0.5
	97	9.5	38.5	9.0	0.8
	60	21.0	100.0	21.0	1.3

Table 3. Effluent Quality (All Analytical Results Expressed in mD/L)

Temperature (°C)	Retention period (min)	Amm. N	Nitrite	Nitrate	Total Oxid. Nitrogen
10	180	4.0	1.1	12.3	13.4
	132	12.0	1.2	9.1	10.3
	97	19.0	0.6	5.7	6.3
	60	23.0	0.0	0.0	0.0
20	180	2.5	2.2	21.2	23.4
	132	6.0	0.8	15.5	16.3
	97	15.0	0.4	8.2	8.6
	60	18.0	0.6	0.0	0.6
30	180	1.0	4.3	15.0	19.3
	132	4.0	0.9	14.5	15.4
	97	11.0	3.5	7.7	11.2
	60	17.0	1.6	0.0	1.6

Effluent quality from the unit operating at different temperature are shown in Table 2 and Table 3. As stated above; quite acceptable results were obtained with retention periods as low as 97 min when even the low temperature, the RBC unit was capable of producing an effluent with a BOD₅ of 17.0 mg/L, a

SS concentration of 14.0 mg/L and 6.3 mg/L total oxidized nitrogen. The equivalent standard of the effluent from the unit operating at 30 °C and at the same retention period was 13.0 mg/L, 10.0 mg/L and 8.6 mg/L. With a 60 min retention period, the unit operated at 20 °C and 30 °C still produced acceptable effluents but that the unit operated at 10 °C was outside normally acceptable limits.

It has been stated that one of the features of the unit is that it does not have a final effluent settlement tank. So that, the suspended solids content of effluent depends on the ability of the last compartment to settle out settleable solids. The results for SS content in effluents invariably include settleable solids as the sample containers were swirled before the portions for SS determination were taken.

Under varying conditions of retention period it was nearly always the unit (at 20 °C) which produced a slightly higher total oxidized nitrogen concentration than the warmer temperature (at 30 °C). Under near optimum conditions at 180 min retention period the relative figures for total oxidized nitrogen were 13/23/19 in the unit operating at 10 °C, 20 °C and 30 °C, respectively. This ratio repeated at a 132 min retention period. As the conditions became more severe with a retention period of 97 min this ratio altered to 6/8/11, and at 60 min became 0/0.7/ 1.7. The nitrite concentration of the effluent from the warmest temperature was invariably higher than that from the unit operating at 20 °C and sometimes reached 5-6 mg/L.

Borchardt (1966) has reported that temperature has little effect on nitrification, and Jenkins (1969) suggested that nitrification continued to increase with temperature within the range investigated as long as a minimum essential DO concentration was available at all times for the nitrifying bacteria. However, the results obtained from this investigation apparently agree with those of Zanoni (1967) who considered the optimum temperature for nitrification to be 22 °C.

These figures, obtained from a laboratory scale RBC unit under conditions of constant feed and temperature, cannot be directly related to operational unit but they do indicate a substantial potential for this type of treatment process, particularly when the low power requirements are compared to those for the activated sludge process and when it is appreciated that no final settlement tank was incorporated in this design.

Sludge was removed daily from the unit and the amounts determined gravimetrically. From the results obtained, it was possible to calculate the rate of conversion of the applied load into sludge solids. Under optimum conditions this was found to be 0.56 g dry solids/g BOD₅ removed for the unit operated at 10 °C and 0.41 at 20 °C and 0.33 at 30 °C. Following the period of operation at optimum conditions the reaction vessel was emptied and the quality of solids in the vessel, on the sides and adhering to the discs was determined. This figure gave an equivalent MLSS concentration of 23 000 mg/L, or between four and eleven times that maintained in activated sludge plants (Metcalf and Eddy, 1991).

4. CONCLUSION

It has been demonstrated that a laboratory scale RBC unit is capable of removing 97.5 % of the applied BOD₅ loading, and can operate efficiently at a loading in excess of 20 g BOD₅/m² day. The ability to remove organic materials increases appreciably with temperature between 10 °C and 20 °C and a lesser extent between 20 °C and 30 °C. Oxidation of ammonia improves significantly from 10 °C to 20 °C but apparently falls off again slightly between 20 °C and 30 °C.

At a disc speed of 4 rpm and a liquid retention period of 97 min, the unit operating in ambient temperatures of 10 °C, 20 °C and 30 °C all produce effluents well within the standards.

5. REFERENCES

- Antonie, R. L. 1976. Fixed Biological Surfaces Wastewater Treatment, Chemical Rubber Company (CRC) Press, Inc., Cleveland, Ohio.
- Boon, A. G. and Burgess, D. R. 1972. Effects of Diurnal Variations in Flow of Settled Sewage on the Performance of High Rate Activated Sludge Plants, *Water Pollut. Control*, 71 (5), 493. P.
- Borchardt, J. A. 1966. Nitrification in the Activated Sludge Process, Div. of San. and Water Resources Eng., University of Michigan, Ann Arbor.
- Ellis, K. V. and Banaga, S. E. I. 1976. A Study of Rotating-disc Treatment Units Operating at Different Temperatures, *Water Pollut. Control*, 10 (1), 73.

- Hittlebaugh, J. A. and Miller, R. D. 1981. Operational Problems with Rotating Biological Contactors, J. Water Pollut. Control Fed., 53 (8), 1283.
- Jenkins, S. H. 1969. Nitrification, Water Pollut. Control, 68 (6), 610.
- Metcalf and Eddy, 1991. Wastewater Engineering: Treatment, Disposal and Reuse, 3rd Edition, McGraw-Hill Book.
- Pike, E. B. 1978. The Design of Percolating Filters and Rotary Biological Contactors, Including Details of International Practice, Water Research Centre, Technical Report, TR93, Medmenham.
- Pike, E. B. Smith, C. H. C. Evans, R. H. and Harrington, D. W. 1982. Performance of Rotating Biological Contactors under Field Conditions, Water Pollut. Control, 81 (1), 10.
- Poon, C. P. C., Chin, H. K. Smith, E. D. and Mikucki, W. J. 1981. Upgrading with Rotating Biological Contactors for BOD Removal, J. Water Pollut. Control Fed., 53 (4), 474.
- Strom, P. F. and Chung, J. C. 1985. The Rotating Biological Contactor for wastewater Treatment, Advances in Biotechnological Processes, 5, 193.
- Torpey, W. Heukelekian, N. H. Kaplovsky, A. J. and Epstein, R. 1971. "Rotating Disks with Biological Growths Prepare Wastewater for Disposal or Reuse", J. Water Pollut. Control Fed., 43 (11), 2181.
- Weng, C. N. and Molof, A. H. 1974. Nitrification in the Biological Fixed-film Rotating Disk System, J. Water Pollut. Control Fed., 46 (7), 1674.
- Wu, Y. C. and Smith, E. D. 1983. Temperature Effect on RBC Scale-up, Pollution Technology Review, 104, 287.
- Zanoni, A. E. 1967. Wastewater Deoxygenation at Different Temperatures, Water Research, 1 (7), 543.
-
-