

## A Novel Generation PV Panel Assisted Hybrid Rotary Energy System with Improved Performance and Design Qualities

Abdurrahman YAVUZDEGER<sup>1\*</sup>, Fırat EKINCI<sup>2</sup>

<sup>1</sup>Adana Alparslan Türkeş Science and Technology University, Energy Systems Engineering, Adana

<sup>2</sup>Adana Alparslan Türkeş Science and Technology University, Energy Systems Engineering, Adana

<sup>1</sup><https://orcid.org/0000-0001-8058-4672>

<sup>2</sup><https://orcid.org/0000-0002-4888-7881>

\*Corresponding author: ayavuzdeger@atu.edu.tr

### Research Article

### ABSTRACT

#### Article History:

Received: 11.02.2022

Accepted: 10.02.2023

Published online: 05.07.2023

#### Keywords:

Renewable energy

Solar energy

Building integrated photovoltaic

Engineering optimization

Greenhouse gases emission have become a worldwide issue. Various research and development studies have been carried out to mitigate the damage caused by global warming to the environment. The number of applications of solar and wind energy in various hybrid structures has greatly expanded. Planning the amount of space necessary for solar and wind energy system installations is one of the most difficult aspects of these energy systems. A novel generation rotary energy system (RES) is proposed in this paper for places with high solar and wind energy potential. By supplying energy demand from a hybrid construction, space will be saved. Solar panels are mounted on the side surfaces of RES. The designed controller for the RES has recorded the power produced by the RES by operating it at various rotational speeds in experimental studies on the roof of Adana Alparslan Turkes Science and Technology University (ATU). The RES that has been developed is intended to be integrated into high-rise buildings. According to the results of the experiments, the RES has a great deal of potential to become an industrial product, if it can be manufactured at higher power levels.

## Geliştirilmiş Performans ve Tasarım Özelliklerine Sahip Yeni Nesil Bir PV Panel Destekli Hibrit Döner Enerji Sistemi

### Araştırma Makalesi

### ÖZ

#### Makale Tarihiçesi:

Geliş tarihi: 11.02.2022

Kabul tarihi:10.02.2023

Online Yayınlanma: 05.07.2023

#### Anahtar Kelimeler:

Yenilenebilir enerji

Güneş enerjisi

Binaya entegre fotovoltaik

Mühendislik optimizasyonu

Sera gazları emisyonu dünya çapında bir sorun haline gelmiştir. Küresel ısınmanın çevreye verdiği zararı azaltmak için yenilenebilir enerji kaynaklarına dayalı enerji sistemleri geliştirilmelidir. Çeşitli hibrit yapılarda güneş ve rüzgar enerjisi uygulamalarının sayısı önemli ölçüde artmıştır. Güneş ve rüzgar enerjisi sistem kurulumları için gerekli alan miktarının planlanması bu enerji sistemlerinin en zor yönlerinden bir tanesidir. Bu makalede, güneş ve rüzgar enerjisi potansiyeli yüksek yerler için yeni nesil bir döner enerji sistemi (DES) önerilmiştir. Enerji talebini hibrit bir yapıdan karşılayarak yerden tasarruf sağlanacaktır. DES için tasarlanan kontrolcü, Adana Alparslan Türkeş Bilim ve Teknoloji Üniversitesi (ATU) çatısında yapılan deneysel çalışmalarda DES'i çeşitli dönme hızlarında çalıştırarak ürettiği gücü kaydetmiştir. Geliştirilen DES'in yüksek binalara entegre edilmesi amaçlanmıştır. Deneylerin sonuçlarına göre, DES daha yüksek güç seviyelerinde üretilebilirse endüstriyel bir ürün olma potansiyeline sahiptir.

**To Cite:** Yavuzdeğer A., Ekinci F. A Novel Generation PV Panel Assisted Hybrid Rotary Energy System with Improved Performance and Design Qualities. Osmaniye Korkut Ata Üniversitesi Fen Bilimleri Enstitüsü Dergisi 2023; 6(2): 1421-1433.

## 1. Introduction

Energy is a necessary phenomenon for human life to continue in a safe and comfortable manner. The dependency and need of people for energy are clearly observed in every aspect of our lives. Energy means almost the same as oxygen to survive for humans. More energy supply is evaluated as an advanced indicator for the countries. Today, there are many different ways to meet energy needs with new technological developments. Energy demand has become an important criterion for measuring the level of development of countries (Tasaki et al., 2021). Improvements in environmental technologies play a significant role in reducing the energy use of developed countries. These countries should consider environmental technologies when developing energy-saving policies (Paramati et al., 2022; Żywiołek et al., 2022). Alternative energy production systems such as hybrid solar and wind energy systems have emerged to provide energy demand. Although wind and solar energy are environmentally friendly, unfortunately, these energy sources also have disadvantages. In order to minimize the disadvantages of solar and wind energy, hybrid energy systems created using these two renewable energy sources are recommended. Many studies have been carried out on size-cost optimization algorithms, techno-economic analysis and power electronics converter topologies to ensure maximum efficiency from hybrid energy systems (Khan et al., 2018; Roy et al., 2022). To solve the power quality problems that occur in hybrid energy systems, optimum sizing studies should be performed (Badwawi et al., 2015; Jayasankar and Vinatha, 2016). The fluctuations of energy production in renewable energy can be mostly occurred in one day. In order to eliminate this problem studies focusing on subjects such as Maximum Power Point Tracking (MPPT), solar and wind power prediction are seen in literature (Calcabrini et al., 2019; Shuvho et al., 2019; Singh and Mohapatra, 2019). Furthermore, solar radiation estimation, cost analysis and optimization algorithms has been working on among the most studied topics. The main purpose of these studies is to increase the energy efficiency from solar and wind energy systems.

Many research and development studies have been carried out on solar and wind energy systems to improve the performance of these energy systems. Successful integration of the photovoltaic (PV) energy system and the swirling wind turbine energy system has been achieved. The vertical axis wind turbine used in this new energy system has a helical three-blade. Performance results of helical blade models with six different twist angle angles were observed. According to the analysis results obtained, the proposed system has 69% efficiency and the optimum rotational speed range has 67 kW output power at 30-34 revolutions per minute (rpm). In addition, the proposed system is presented to be more economical than the single PV energy system (He et al., 2019). In China, use of a photovoltaic energy system and an energy storage method are provided as an auxiliary power source to meet the energy needs of a passenger train. The control of this auxiliary power system are examined in detail. Energy-saving and emission reduction are clearly observed with the proposed system (Wei et al., 2016). In order to improve the performance of photovoltaic energy systems under partial shading conditions, a

new analytical model is proposed considering the effect of both series and shunt resistance. According to the obtained data, the reliability of the developed analytical model has been demonstrated. It has also been proven that it can be used to model grid-integrated photovoltaic energy systems (Vankadara et al., 2022). As a result of overheating of solar PV panels, panel efficiency decreases so various studies are carried out to increase the energy produced by keeping the panel temperature at an optimum level. Due to the rapidly increasing global water crisis, strategies are being developed to ensure environmental sustainability. (Khan et al., 2022). A novel application in which water in reverse osmotic systems is used to cool PV panels has been proposed in the literature. The payback time, electrical and thermal performance of the solar energy system in the solar PV panel-supported reverse osmotic system have been investigated experimentally (Talebnejad et al., 2022). Inadequate insulation systems in buildings directly affect energy consumption. The effects of the integration of the solar PV panel with the most suitable insulation system according to the roof structure on the energy consumption of the buildings are examined in detail. In addition, it is concluded that the shadow of the PV arrays on the roofs reduces the consumed energy for cooling by 17% in the summer period (D'Agostino et al., 2022). Partial shading conditions are one of the most important problems that negatively affect the power produced in solar PV energy systems. To eliminate the situations where this problem arises, a comprehensive review of recent MPPT techniques is presented. According to the use of various MPPT methods, the reduction rates of power losses are examined comparatively (Mishra et al., 2022; Jalil et al., 2022). Hybrid MPPT algorithms are widely recommended to improve the performance of maximum power tracking techniques. The performance of a hybrid algorithm consisting of a combination of Harris Hawk optimization and traditional Perturb and observe (P&O) algorithms is observed in MATLAB software in different weather conditions. The performance of the developed hybrid algorithm is compared with four different algorithms and the superiority of the proposed algorithm is presented in detail (Hafeez et al., 2022). It is observed that the performance of the MPPT algorithm is increased by modifying the traditional MPPT algorithms introduced in the literature. A modified P&O algorithm has been developed to improve the MPPT efficiency in photovoltaic panels. The PV system tracking efficiency of the proposed algorithm, which reaches 99.7%, has been proven in MATLAB by comparing it with traditional MPPT algorithms (Ali et al., 2022). In order to utilize solar energy with maximum efficiency, performance results of ten different MPPT algorithms have been compared and presented in detail. In addition, it is explained that solar energy is an indispensable energy source for our future. The optimized Incremental Conductance and P&O algorithms are clearly observed in terms of their cost and performance. Also, MPPT systems are compared in terms of cost (Faranda et al., 2008). The effect of the developed control algorithm and the P&O algorithm on the output power of the PV panel is presented comparatively. The results obtained provide high gain with the proposed transducer and quickly track maximum power point in moving partial shading conditions (Raizada and Verma, 2018). The design and performance analysis results of a new energy system consisting of rotational PV panels are performed. The availability of this system

has been observed in supplying the energy need for buildings. The efficiency of the proposed new design PV system under different artificial light has been tested. Among the seven different artificial lights, Metal Halide Lamp has artificial light that increases the efficiency of the proposed system the most. High-pressure sodium lamp has the lowest artificial light performance in obtaining energy from the proposed system (Bagheritabar et al., 2018). For the hybrid energy system at maximum efficiency, an MPPT controller is developed. Thus, the power quality problem caused by loading and ambient conditions is minimized. Simulation results obtained from MATLAB software and the effects of the designed controller on the hybrid energy system are presented in detail (Sharma et al., 2018).

The main aim of this paper is to present an effective hybrid RES in places with high solar and wind energy potential. The design and manufacture of the developed system are discussed in detail in the following sections of the paper.

## 2. Material and Method

Hybrid energy systems, in particular, can be made up of various structures that combine solar and wind energy. Hybrid energy system topologies vary depending on whether the loads are alternating current or direct current. The I-V characteristics and efficiency of PV panels are based on mathematical modeling of PV cells. The equivalent circuit model of the solar cell was presented by Lorenzo in 1994 (Lorenzo, 1994). Single-diode mathematical model of a PV cell is shown in Figure 1.

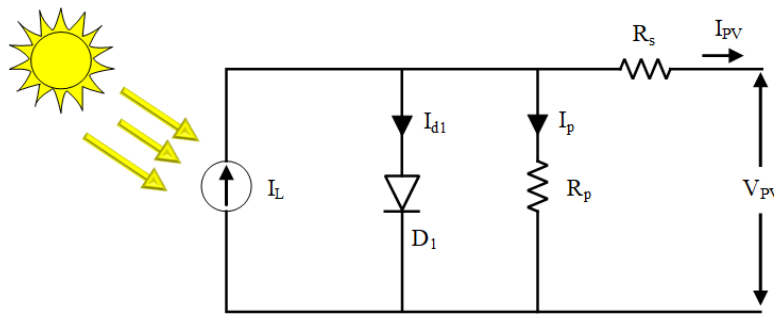

**Figure 1.** Mathematical modeling of PV cells with one diode

The I-V characteristic of a solar cell is basically the practical model of PV cell based on Equations (1) and (2) below.

$$I_{PV} = I_{d1} \left[ \exp\left(\frac{q \cdot V_{PV}}{kT} - 1\right) \right] \quad (1)$$

$$I_{PV} = I_L - I_{d1} \left[ \exp\left(\frac{q(V_{PV} + R_s \cdot I_{PV})}{n \cdot k \cdot T} - 1\right) \right] - \frac{V_{PV} + R_s \cdot I_{PV}}{R_p} \quad (2)$$

where ideality factor is ( $n$ ), series resistance is ( $R_s$ ), parallel resistance is ( $R_p$ ), Boltzmann constant is ( $k$ ) ( $1.381 \times 10^{-23}$  J/K), electron charge is ( $q$ ) ( $1.602 \times 10^{-19}$  C), and solar cell temperature is ( $T$ ). Equation (3) can be utilized to express the solar cell voltage by using Equation (2). Also, ( $R_p$ ) has been ignored.

$$V_{PV} = \frac{n \cdot k \cdot T}{q} \ln \left[ \frac{I_L + I_{d1} - I_{PV}}{I_{d1}} \right] - R_s \cdot I_{PV} \quad (3)$$

In the solar cell module, the number of serial cells is expressed as  $N_s$  and the number of parallel cells is expressed as  $N_p$ . Figure 2 illustrates the equivalent circuit model for various PV cell configurations. Serial cells are increased in order to increase the voltage level in PV modules.

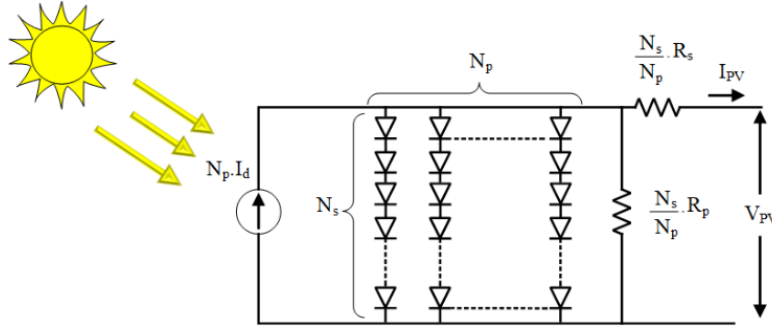

**Figure 2.** Solar cell module electrical equivalent circuit with diode in series/parallel

The total current and voltage expression of the solar cell module whose equivalent circuit is as in Figure 2 is shown in Equation (4) and Equation (5), respectively.

$$I_{PV} = N_p \cdot I_d - N_p \cdot I_{d1} \left[ \exp \left( q \left( \frac{V_{PV}}{N_s} + \frac{I_{PV} \cdot R_s}{N_p} \right) k \cdot T \cdot A \right) - 1 \right] - \left( \frac{N_p \cdot V_{PV}}{N_s} + I_{PV} \cdot R_s \right) / R_p \quad (4)$$

$$V_{PV} = \frac{N_s \cdot n \cdot k \cdot T}{q} \ln \left[ \frac{I_L + I_{d1} - I_{PV} + N_p}{I_{d1} \cdot N_p} \right] - \frac{N_s}{N_p} R_s \cdot I_{PV} \quad (5)$$

where  $A$  is area of cell, the output current of the solar cell module is  $I_{PV}$  and the output voltage of the solar cell module is  $V_{PV}$ .

There are many critical parameters that affect the efficiency of photovoltaic energy systems. These parameters include shading, dusting, reflection, humidity, temperature, panel location, panel angle, air pollution, environmental factors, location, and panel cleaning. To obtain maximum efficiency from solar energy, the effects of these parameters on solar energy systems should be examined in detail. Because the changes in these critical parameters directly affect the amount of energy to be obtained from solar energy systems. Temperatures rises are undesirable in PV energy systems. As shown in Figure 3, special air ducts and the rotation movement of the RES has been prevented the panels from overheating.



**Figure 3.** The special air ducts of the RES

The some parts of prototype are produced utilizing 3D printer. The production method has been made more cost-effective. Moreover, the RES is made up of lightweight components. The RES is 210 mm in height and 295 mm in diameter. Number of ten solar panels have been integrated on the RES at certain intervals. During rotational motion, the wires of the panels installed on the developed RES become entangled. To overcome this problem, a slip ring was used in the RES. The RH50.S0605 hollow shaft series slip ring for RES has been used. Figure 4 illustrates the dimensions for the slip ring utilized in the RES. The successful integration of RES components produced by 3D printer with PV panel and slip ring is presented in Figure 5.

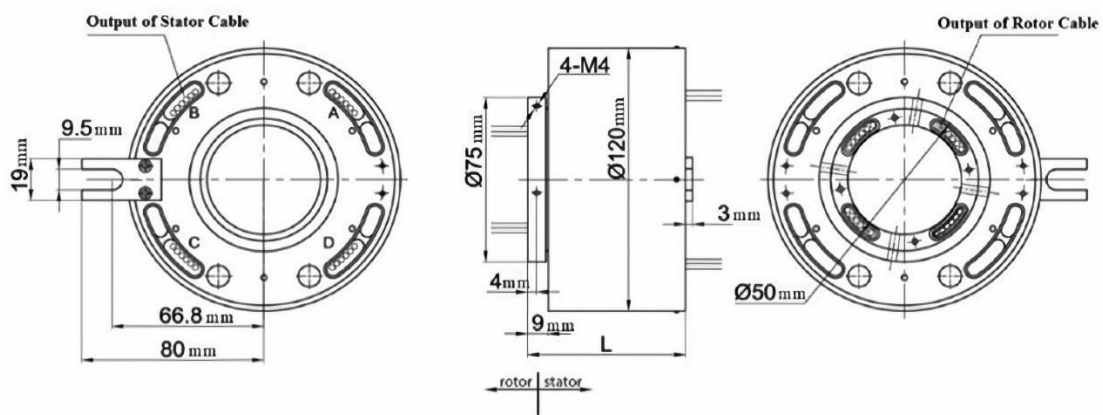

**Figure 4.** Dimensions of the slip ring

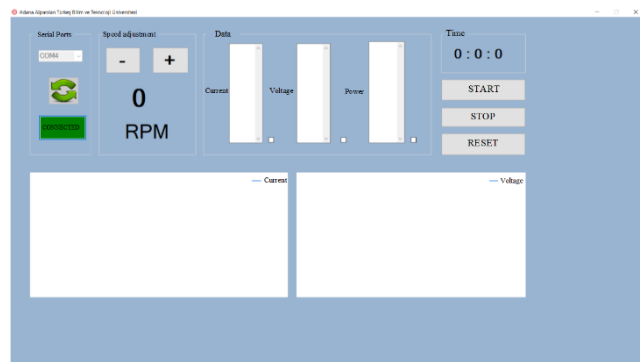

**Figure 5.** The proposed RES

In experimental studies, the controller interface controls the rotational speed of the RES. The rotating speed of RES can be adjustable up to 100 rpm. Thanks to the developed controller, the graphics of current and voltage values are created instantly in controller interface. In this way, these values of the RES can be observed at the time. Figure 6 illustrates the controller and controller program's interface. The "RS-232" serial communication provides data flow between the developed program and the proposed RES. In this serial communication, the program interface receives the output voltage and current data of the rotary system. Rotational speed (rpm) data is sent to the controller through the program interface. This program shows the time-dependent graph of the current and voltage values it receives. The received and sent data are recorded in the Comma Separated Values (CSV) format. Thus, this data can be used in data processing programs such as Matlab, Excel, etc.



(a)



(b)

**Figure 6.** (a) The controller of the RES (b) the controller program's interface



### 3. Results and Discussion

The performance analysis are conducted to assess the prototype system's reliability and efficiency under various climate conditions. The proposed RES has been installed on the roof of the ATU as shown in Figure 7.



**Figure 7.** The experimental setup consisting of RES, controller and PLC measuring station

The controller of the RES has recorded output power, current, and voltage data with one-second logging interval. The RES's data curves at 0 rpm, 10 rpm, 50 rpm and 100 rpm are shown in Figure 8, respectively.

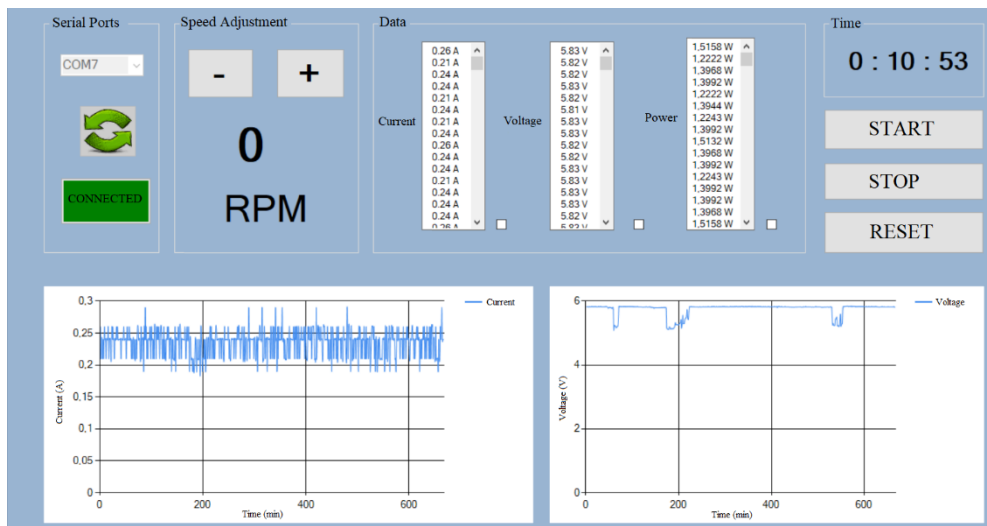

(a)



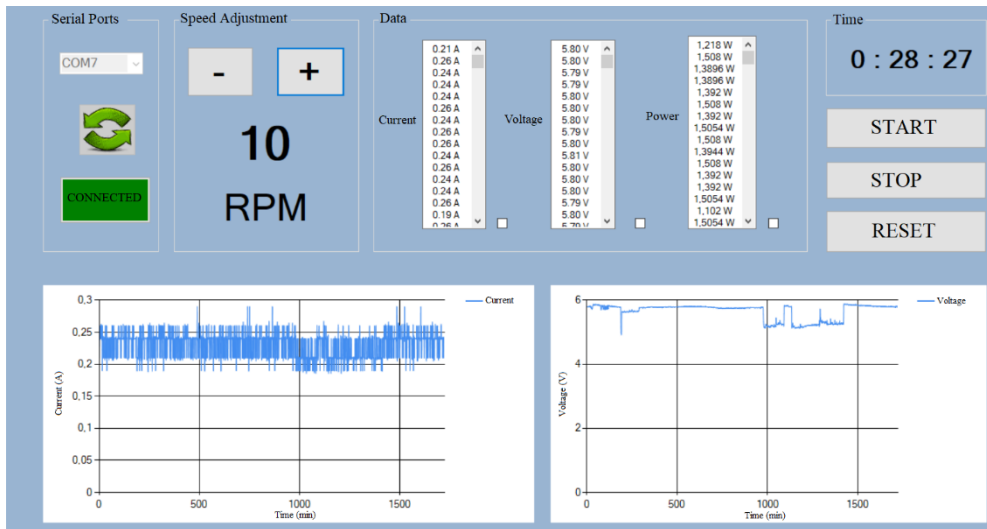

(b)

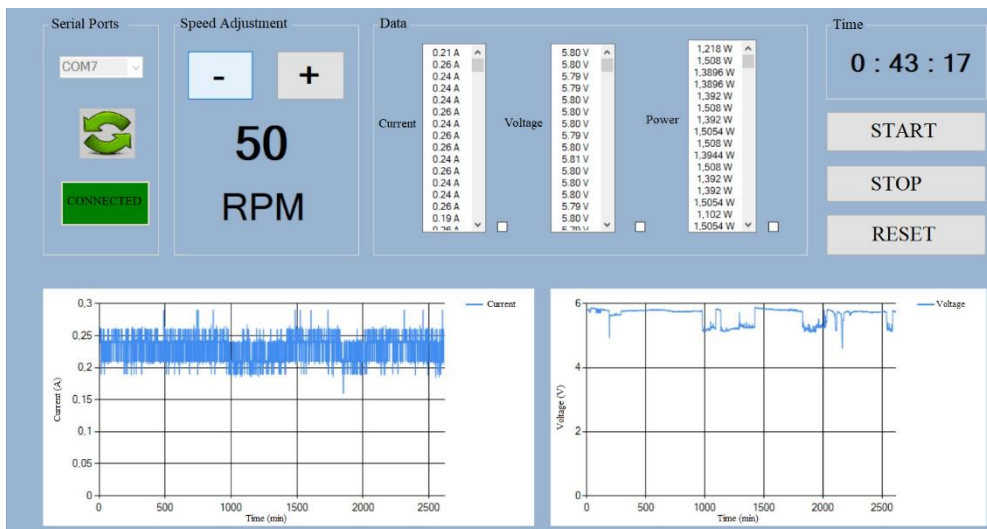

(c)

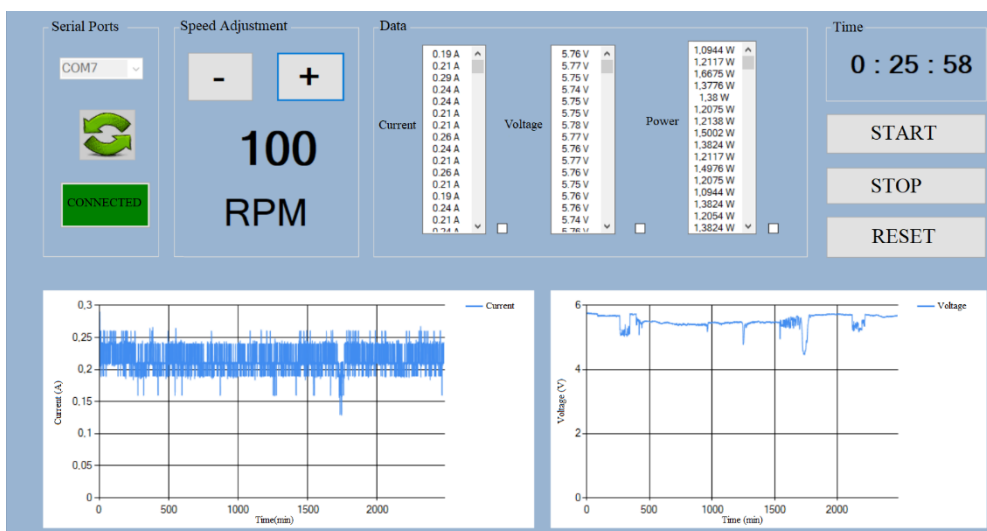

(d)

Figure 8. The RES's current and voltage curves at 0 rpm, 10 rpm, 50 rpm and 100 rpm, respectively.

The PLC measuring station collects data the solar radiation and ambient temperature in the experimental studies. These data have been instantly examined from the Human-Machine Interface display in the PLC measuring station. The solar radiation and RES's output power values under various climate conditions are given in Table 1. It is observed that the lowest and highest solar radiation values at the experimental studies are 110 W/m<sup>2</sup> and 1210 W/m<sup>2</sup> respectively. According to the experimental results, the effect of rotation speed up to 50 rpm on the output power could not be observed significantly. The highest output power is measured 1.8067 W at 100 rpm and 1089 W/m<sup>2</sup>.

**Table 1.** The solar radiation and output power values of the RES.

<b>Rpm</b>	<b>Solar Radiation (W/m<sup>2</sup>)</b>	<b>RES Output Power (W)</b>
0	1155	1.6120
10	1210	1.7893
50	1035	1.7777
100	1089	1.8067

As dusting on the solar PV panel surface and panel temperature directly affect the energy produced these two parameters are of vital importance in solar PV panel applications. A RES has been developed to minimize these two problems. Thanks to the rotation movement creating a natural cooling effect, heat accumulation on the surface of the Solar PV panel is prevented. Moreover, as a result of the rotational movement of the proposed RES and the position of the PV panels on RES, dust accumulation on the PV panels is prevented. Thus, it has been observed that in the developed RES, these problems are overcome by rotational motion. The RES in the coming years will be designed at higher power levels and will contribute to daily energy consumption in homes.

#### **4. Conclusion**

Energy demand has increased with the rapid growth in technological developments in recent years. Carbon emissions increase significantly due to energy production systems based on fossil fuels to meet the energy demand. To overcome this negative situation should be studied environmentally friendly energy systems by developing energy systems based on renewable energy sources. This paper, it is aimed to bring a novel rotary hybrid system to the literature and to provide the necessary data for the transformation of this prototype into a product. It is presented that the design and manufacturing of RES. The 3D printer technology is used in the manufacture of the proposed RES. As a result, low cost, lightness, extended life, and reliability are all guaranteed. A detailed evaluation has been made thanks to the data obtained from experimental results. Experimental studies of the RES at operated different rpm have been performed to observe the effect of the rotation speed on the output power between 110 W/m<sup>2</sup> and 1210 W/m<sup>2</sup> solar radiation. It's likely that the RES will be developed into a commercial product with more power levels.

## **Acknowledgment**

The authors would like to acknowledge the Scientific Project Unit of Adana Alparslan Turkes Science and Technology University (Project Number: 19103006) for full financial support.

## **Statement of Conflict of Interest**

Authors have declared no conflict of interest.

## **Author's Contributions**

The contribution of the authors is equal.

## **References**

- Ali AIM., Mohamed HRA. Improved P&O MPPT algorithm with efficient open-circuit voltage estimation for two-stage grid-integrated PV system under realistic solar radiation. *International Journal of Electrical Power & Energy Systems* 2022; 137: 107805.
- Badwawi RA., Abusara M., Mallick T. A review of hybrid solar pv and wind energy system. *Smart Science* 2015; 3: 127–138.
- Bagheritabar M., Bagheitabar H., Kashani MMR., Khodashenas, NS. Photovoltaic systems with rotational panels to harvest natural and artificial light for electrical production. *5th International Conference on Electrical and Electronic Engineering (ICEEE)*, 2018; 211–214.
- Calcabrini A., Ziar H., Isabella O., Zeman M. A simplified skyline-based method for estimating the annual solar energy potential in urban environments. *Nature Energy* 2019; 4(3): 206–215.
- D'Agostino D., Parker D., Melià P., Dotelli G. Optimizing photovoltaic electric generation and roof insulation in existing residential buildings. *Energy and Buildings* 2022; 255: 111652.
- Faranda R., Leva S., Maugeri V. MPPT techniques for PV systems: Energetic and cost comparison. *IEEE Power and Energy Society General Meeting-Conversion and Delivery of Electrical Energy in the 21st Century*, 2008; 1–6.
- Hafeez MA., Naeem A., Akram M., Javed MY., Asghar AB., Wang Y. A novel hybrid MPPT technique based on harris hawk optimization (HHO) and perturb and observer (P&O) under partial and complex partial shading conditions. *Energies* 2022; 15: 5550.
- He Y., Zhang M., Li W., Su J., Kase K., Yu CW., Gu Z. Feasibility of a new helical blade structure for a PV integrated wind turbine in a heat-driven swirling wind field. *Energy* 2019; 185: 585–598.
- Jalil MF., Khatoon S., Nasiruddin I., Bansal RC. Review of PV array modelling, configuration and MPPT techniques. *International Journal of Modelling and Simulation* 2022; 42: 533–550.
- Jayasankar VN., Vinatha U. Implementation of adaptive fuzzy controller in a grid connected wind-solar hybrid energy system with power quality improvement features. *2016 Biennial*

- International Conference on Power and Energy Systems: Towards Sustainable Energy (PESTSE), Bangalore: IEEE; 2016, p. 1–5.
- Khan FA., Pal N., Saeed SH. Review of solar photovoltaic and wind hybrid energy systems for sizing strategies optimization techniques and cost analysis methodologies. *Renewable and Sustainable Energy Reviews* 2018 ; 92: 937-947.
- Khan SAR., Ponce P., Yu Z., Golpîra H., Mathew M. Environmental technology and wastewater treatment: Strategies to achieve environmental sustainability. *Chemosphere* 2022; 286: 131532.
- Lorenzo E. *Solar electricity: Engineering of photovoltaic systems*, Earthscan/James & James, 1994.
- Mishra VL., Chauhan YK., Verma KS. A critical review on advanced reconfigured models and metaheuristics-based MPPT to address complex shadings of solar array. *Energy Conversion and Management* 2022; 269: 116099.
- Paramati SR., Shahzad U., Doğan B. The role of environmental technology for energy demand and energy efficiency: Evidence from OECD countries. *Renewable and Sustainable Energy Reviews* 2022; 153: 111735.
- Raizada S., Verma V. Step up gain converter with fast MPPT control under moving partial shading for train rooftop PV-DC- $\mu$ G. *IEEE International Conference on Electrical Systems for Aircraft, Railway, Ship Propulsion and Road Vehicles & International Transportation Electrification Conference (ESARS-ITEC)*, 2018; 1–6.
- Roy P., He J., Zhao T., Singh YV. Recent advances of wind-solar hybrid renewable energy systems for power generation: A review. *IEEE Open J Ind Electron Soc* 2022; 3: 81–104.
- Sharma A., Singh HP., Sinha SK. Performance enhancement of integrated solar-wind hybrid energy system using MPPT. *3rd International Innovative Applications of Computational Intelligence on Power, Energy and Controls with Their Impact on Humanity (CIPECH)*, 2018; 1–4.
- Shuvho MBA., Chowdhury MA., Ahmed S., Kashem MA. Prediction of solar irradiation and performance evaluation of grid connected solar 80KWp PV plant in Bangladesh. *Energy Reports* 2019; 5: 714–722.
- Singh SN., Mohapatra A. Repeated wavelet transform based ARIMA model for very short-term wind speed forecasting. *Renewable Energy* 2019; 136: 758–768.
- Talebnejad R., Kamfiroozi S., Ebadi H., Vahabi SH., Sepaskhah AR., Ghobadian B., Savoldi L. A new cooling method for photovoltaic panels using brine from reverse osmosis units to increase efficiency and improve productivity. *Energy Conversion and Management* 2022; 251: 115031.
- Tasaki T., Tajima R., Kameyama Y. Measurement of the importance of 11 sustainable development criteria: How do the important criteria differ among four Asian countries and shift as the economy develops? *Sustainability* 2021; 13: 9719.
- Vankadara SK., Chatterjee S., Balachandran PK. An accurate analytical modeling of solar photovoltaic system considering  $R_s$  and  $R_{sh}$  under partial shaded condition. *Int J Syst Assur Eng Manag* 2022; 13: 2472–2481.

Wei M., Wei W., Ruonan H., Ziyi W. Auxiliary power supply system of passenger train based on photovoltaic and energy storage. IEEE 11th Conference on Industrial Electronics and Applications (ICIEA), 2016; 784–788.

Żywiołek J., Rosak-Szyrocka J., Khan MA., Sharif A. Trust in renewable energy as part of energy-saving knowledge. Energies 2022; 15: 1566.