

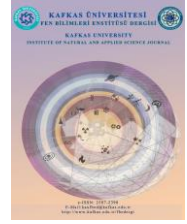

Kafkas Üniversitesi Fen Bilimleri Enstitüsü Dergisi Institute of Natural and Applied Science Journal

Dergi ana sayfası/ Journal home page: <https://dergipark.org.tr/tr/pub/kujs>



E-ISSN: 2587-2389

The Development of a Cooling System App for Immobile Patients

Ramiz SALAMA ^{1*}

¹Department of Computer Engineering, AI and Robotics Institute, Research Center for AI and IoT, Near East University, Nicosia, Cyprus

(İlk Gönderim / Received: 05. 07. 2022, Kabul / Accepted: 24. 11. 2022, Online Yayın / Published Online: 12. 12. 2022)

Keywords:

Microcontroller,
speed,
temperature,
liquid crystal display (LCD),
sensor.

Abstract: In the 21st century, as technology advanced and individuals sought to maximize their use of time, there was an increase in the usage of automated systems, which led to the prominence of microcontrollers. The well-known Arduino tiny portable microcontroller is one of the finest in the world today for creating quick, effective automated gadgets that support daily living. This paper is entirely dedicated to the COOLING SYSTEM driven by ARDUINO. This is a look at a flexible project that may be utilized in a variety of settings, including places and things that people use on a regular basis. With the development of technology in the twenty-first century, people are increasingly seeking for ways to save time, which has led to an increase in the usage of automated systems, with microcontrollers emerging as key actors. One of the greatest in the world today for creating quick, effective automated gadgets that support daily living is the well-known little portable microcontroller called Arduino. The ARDUINO driven COOLING SYSTEM is the focus of this article. This is a glimpse into a flexible project that may be utilized in a variety of contexts, including everyday items and public spaces. This book is intended for a wide range of audiences, including students studying the expressive arts, middle and senior secondary school students, students studying building structures, as well as practicing researchers and architects. The book has been divided into sections to accommodate this large audience and satisfy the needs of each reader. The book includes a ton of product and equipment information that can assist readers in constructing a wide range of structures. The Arduino Mega 2560 equipped with the Atmel ATmega 2560 and the Arduino UNO R3 supplied with the Atmel ATmega 328 are two different Arduino products that are covered in the book. The third release has been refreshed with the most recent on these two handling sheets, changes to the Arduino Development Environment, and different expanded models.

Hareketsiz Hastalar İçin Soğutma Sistemi Uygulaması Oluşturma

Anahtar Kelimeler:

Mikrodenetleyici,
hız,
sıcaklık,
sıvı kristal ekran (LCD),
sensör.

Özet: 21. yüzyılda teknolojinin gelişmesiyle birlikte otomatik sistemlerin kullanımında bir artış var, insanlar zamanı en çok denemek ve kullanmak için sabırsızlanıyorlar ve bununla birlikte Mikrodenetleyiciler önemli oyuncular haline geldi. Popüler küçük taşınabilir mikrodenetleyici Arduino, günlük yaşamda yardımcı olan hızlı verimli otomatik cihazlar yapma açısından günümüzün en iyilerinden biridir. Bu belge tamamen ARDUINO destekli SOĞUTMA SİSTEMİ ile ilgilidir. Bu, günlük kullanılan nesnelere ve insanlar tarafından alanlar dahil olmak üzere farklı alanlarda uygulanabilen çok yönlü bir projeye ilişkin bir fikirdir. Bu SOĞUTMA uygulamasının insan yaşamını iyileştireceğine ve ayrıca insanları mikrodenetleyicilerin kullanımını ve gücü konusunda eğiteceğine inanıyorum. Bu kitap Arduino mikrodenetleyicisi ve Arduino fikri hakkındadır. Massimo Banzi, David Cuartillas, Tom Igoe, Gianluca Martino ve David Mellis'ten oluşan vizyoner Arduino grubu, 2005 yılında mikrodenetleyici ekipmanında açık kaynak ekipmanı fikri olan başka bir gelişmeyi harekete geçirdi. Metodolojileri, düşüncelerin paylaşımını canlandırmak ve gelişimi ilerletmek için mikrodenetleyici tabanlı ekipman planı aşamalarının inceliklerini doğrudan paylaşmaktı. Bu fikir, ürün dünyasında uzun süredir yaygın. Bu kitap, dışavurumcu sanatlar yedeği, merkez ve ortaokul yedeği, bina strüktür yedeği ve prova araştırmacıları ve mimarları da dahil olmak üzere çok çeşitli insan toplantıları için planlanmıştır. Bu geniş izleyici grubunu karşılamak için kitap, her kullanıcının ihtiyacını karşılamak üzere

bölmelere ayrılmıştır. Kitap, okuyucunun çok çeşitli çerçeveler oluşturmasına yardımcı olacak çok sayıda ürün ve ekipman kılavuzu içerir. Kitap iki farklı Arduino ögesini kapsar: Atmel ATmega 328 ile donatılmış Arduino UNO R3 ve Atmel ATmega 2560 ile donatılmış Arduino Mega 2560. Üçüncü sürüm, bu iki işleme sayfasındaki en son sürüm, Arduino Geliştirme Ortamındaki değişiklikler ve farklı genişletilmiş modellerle yenilendi.

*İlgiliyazar: ramiz.salama@neu.edu.tr

1. INTRODUCTION

The project's Arduino cooling system monitors and regulates the ambient temperature. The Arduino microcontroller, which is increasingly being used to actualize power over frameworks, was used to design the framework. Considering that the framework is supposed to regulate the cooling system. Understanding Arduino-controlled frameworks is so essential. These days, thanks to the advancement of innovation, particularly in the area of microcontrollers, every aspect of daily life has become a kind of data innovation, and we have found controllers in every single application (Buonocunto P. et al., 2014; Buonocunto P. et al., 2016; Restuccia F. et al., 2022). The design is geared at small-scale controller-based conducting work in this way. The main objective of this file is to display the temperature and, when it reaches a certain maximum, to manage it in order to return it to the appropriate temperature in order to reduce energy and time waste and assist those who are disabled and unable to control the temperature to their preferences. It might also be used to monitor situations changing as quickly as possible. It may very well be used in a variety of businesses and electrical devices. Assembling a programmable framework using a microcontroller and its interaction with other devices is another design.. The Arduino turns out to be progressively prevalent given its numerous favorable circumstances like straightforward programming and conservative size. It likewise underpins various gadgets, so we will likely accomplish the capacity to do programming and get thought regarding the Arduino framework. In any sort of venture which requires a useful, modified or exploratory field test, there are problems experienced because of vulnerabilities and testing issues. In this venture, we can say for each segment of the assignments, there were challenges that we experienced. Since we will be dealing with circuitry, arranging a circuit without testing in the event that it works might be an issue. There are such a large number of types of automatic (self-operating) systems out there, some with various hardware structures and choosing the one to take needs a type of solid confidence that it will work (Heimerdinger W.L. et al., 1992; Yuan D. et al., 2014; Stonebraker M. et al., 2018). So, I experienced preliminaries and mistakes until I found the correct circuit. There are a large number of approaches to developing an automatic system as there are many controllers out there nowadays. One can use Raspberry pi and other controllers with or without a Wi-Fi connection, Wi-Fi connection for interface and notifications and easy control. I tried with raspberry pi. It did not work well due to different part and the simplicity of the project goal, and more of the accessories were expensive. The other problem was the choice of selecting the sensor, mainly the temperature sensor, because the sensor should give an almost accurate temperature for the project to run to specifications. The problem I faced here is that I first used a sensor which reads the temperature correct but when it was time to cool down

and read the current temperature, it would give out the wrong values. Then they chose to use another sensor, the LM35 sensor, which did pretty well at handling these temperatures. Other problems were with making the device wirelessly connected so users or users could operate and use the system adjusted to their wants. But, this failed as the ESP8266 WIFI module I wanted to use is a microcontroller on its own and merging it into the whole project made the whole project complex. Hence, it is supposed to be simple. One of the big problems was buying all the accessories for the project. They would bought and get damaged, and would be sent back and, with time, I had to work with what I had as I couldn't get replacements due to the great pandemic of 2020. Taking into account how smart the bleeding edge improvement is affecting, adaptable or controlled frameworks are and by anticipating focal occupations in supporting individuals on the planet. These self-working frameworks can be evaluated to fit into various regions and work vary. This obligation is valuable for security and observation if there is an occurrence of attack assignments or workers blame and unfortunate behavior where a human can neglect to be accessible or disregard the specific undertaking, utilization of helpful or self- working frameworks sneaks in, people spot where they can spare and improve the circumstance without everyday checking, and for the proficiency of both human agents and machines, Programmed self-working frameworks can be worked with various methodologies that draw in them to go into bound spots where it is perilous or not appropriate for a human individual to stay and work, particularly because of working time. In cutting edge life, asset abuse has expanded because of the expansion of the populace on the planet. Thus, the interest and use and shortage of power has made the charges high. This sort of self-working framework chips in spring and, furthermore, improves the world by dispensing with the over the top utilization of vitality and furthermore of putting another person to staying taking care of specific machines.

One other enormous obligation of this arrangement is in training understudies. This subject can assist them with understanding the chance of mechanical and electronic advances behind applying self-governance, how significant it is in various territories, and how to improve its presentation and help individuals who are not in the field to comprehend robots on how they help us not to on an exceptionally essential level displace us. Facing the subject, we can credit students for business openings in the related field of study. Since we are moving into a future where you will see self-working frameworks all over, this endeavor arrangement may help build up a couple of systems for different activities.

Any sort of task takes a number of occasions and works to get to its end. The occasions and work are performed in various parts along a specific time span. Figure 1 is the Gantt outlined portrayal of the course of events of the undertaking project design. From the fourth of May to roughly the end of December, goals have been spread in the middle as indicated

by the data on the graph. The graph shows that the first initial goal was the design selection and the task choice for each group member and it took the last time to finish, i.e. two days. After that came one of the long span goals, termed proposition composing and research arc 1 which took twenty-five and thirty days individually and respectively. The first research arc was, for the most part, connected with the design proposal, yet some pieces of it were connected to the listing of elements to build the robotic design with all things considered ten days to finish. What followed was the programming adapted for the first session in ten days. These ten-day programming arcs on the graph are one of the most important events of this design, along with the second arc in the tenth place after ordering listed components, the beginning of report writing, the research arc number 2 then the potential time for the shipments to arrive. All these took a period of five, fifteen, twenty and seven days respectively.

Above shows the expected timeline of the project in the form of a Gantt chart representation. It is roughly estimated to reach completion in the course of six months, ranging from December 2019 to July 2020. The initial step involves the

selection of the project and the designated tasks on 5 December 2019, followed by a research phase when members in the group will study the main objectives and how to implement the project as a whole and the designated tasks. For the whole month of January it was the programming test the code finding the shortest and easiest program whereby will be choosing the best alternative, Aquino platform IDE and respective components codes. After all the components are available, then comes the task of assembling and modelling the system, starting by sketching the flow chart, which is the first objective of the project. The next 15 days involve the third objective, which is the component testing as many components arrive damaged after completion of this task. Will then move on to the testing phase so as to improve efficiency and reduce errors from the 15th of May to the 1st of March. Then, according to the results of our testing, we will make the necessary modifications. All these steps done on the project will be very near completion and, for the whole of April to June, will comprise writing a report, preparation of the graduation presentation alongside with the poster then followed the presentation itself thus concluding the timeline.

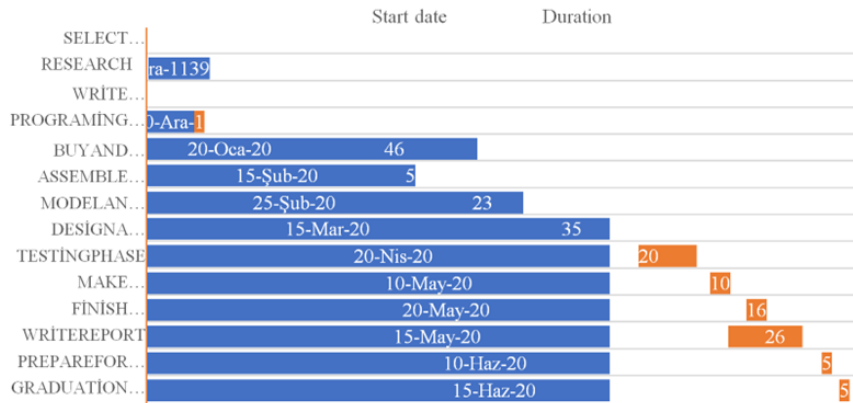

Figure 1. Layout of the timeline of event for the Design.

2. MATERIAL AND METHOD

2.1. Budget

Materials are expected to make this venture a triumph. In light of that there will be a rundown and the measure of monetary consumption for everything available.

Table 1 is the materials and cost price for the project. The table is showing the items required with a total of fifty-seven pieces and a total cost of sixty-four US dollars, fifty-three cents to be share among five members. It will be twelve dollars and ninety-one cents per member. The current cost prices are from Gear best, Amazon and Ali-express websites (Heimerdinger W.L. et al., 1992; Guglielmetti J.L. et al., 1996; Yuan D. et al., 2014).

Table 1. Materialistic elements and cost for the design.

ITEM	EXPLANATION	UNIT (pcs)	UNIT COST (\$/pcs)	AGGREGATE (\$) shipping cost
Arduino Uno R3	Microcontroller (Brain of the robot)	2	9,84	19,68
Liquid crystal display	1602d, 16pin	1	2.99	3.20
Jumper Wires	200mm Male to female and male to male connection cables	40	0,11	4,40
Breadboard	MB102, 830 point unsoldered printed circuit board	2	2,03	4,09 + 0,29 shipping cost
Battery	AA rechargeable (lithium)	4	6,93	27,72
DC Fan	12v (power source) the cooling source	1	1,12	2,50
Resistors	control the flow of current to other components	3	0.10	-
TOTAL	Total cost of the components	66	Varies	118.34

2.2. Review of Literature and Theories Employed

As observed from the section title, it contains two segments which will be separated in a similar order, the initial segment is for dialogues relating to previous work that has been done identical to this design and the subsequent part has a plan on a similar subject to be finished by the end of the year 2019. In this file, everything is focused and aligned with the use of microcontrollers. A microcontroller is a PC. All PCs - regardless of whether we are discussing an individual personal computer or a huge centralized computer PC or a microcontroller - share a few things. Microcontrollers are "installed" inside some other gadget (frequently a shopper item) with the goal that they can control the highlights or

activities of the item. Another name for a microcontroller, in this way, is the "inserted controller." Microcontrollers are regularly low-control gadgets. A work station is quite often connected to a divider attachment and might expend 50 watts of power. A battery-worked microcontroller may expend 50 milliwatts. A microcontroller has a committed information gadget and frequently (yet not generally) has a little LED or LCD show for yield. A microcontroller likewise takes contribution from the gadget it is controlling and controls the gadget by sending a sign to various segments in the gadget. For instance, the microcontroller inside a TV takes a contribution from the remote control and shows the yield on the TV screen.

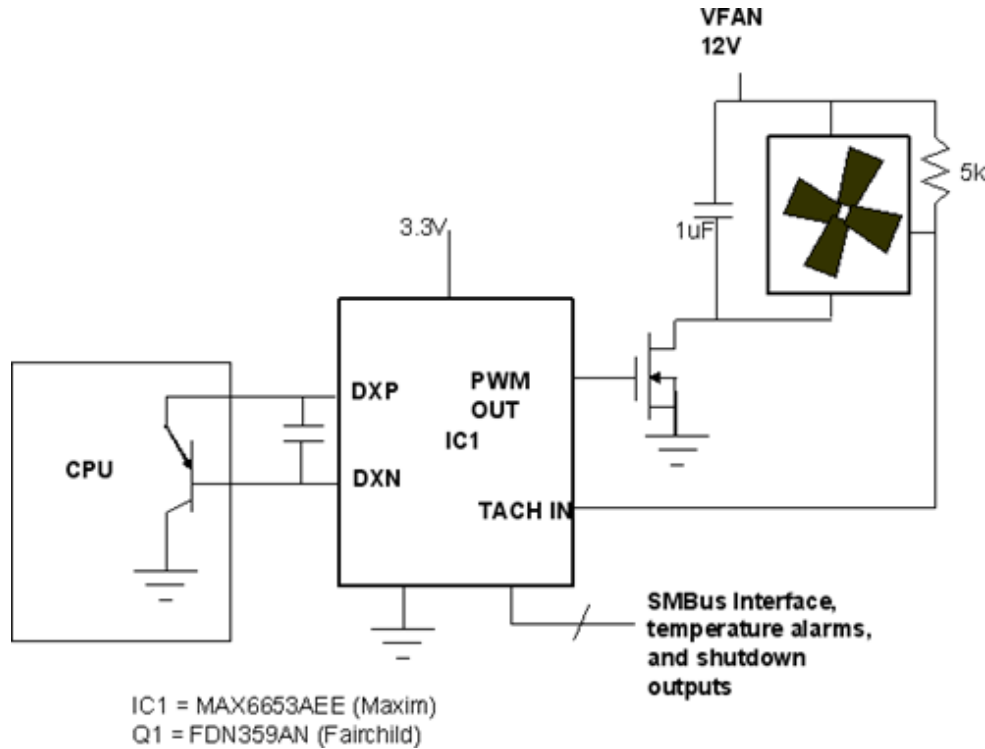

Figure 2. Circuit and gate pathways.

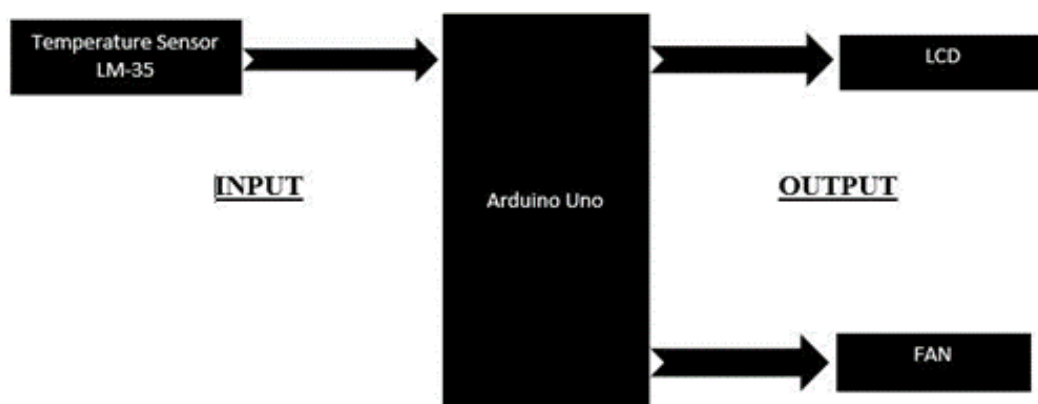

Figure 3. Block diagram representation.

In these circuits the microcontroller is used to control the fan according to the temperature variation. The LM35 functions to measure the changes of temperature surrounds

the area. All the operations are controlled by the arduino to produce the output. The LCD, fans are the output where they are set with the pseudo code. There is a broad diversity of

automatic cooling systems varying from different microcontrollers utilized, different circuitry design arrangement and the materials used to construct the whole system. In this current chapter, will discuss upon the design of the cooling system. We will later bring up other alternatives for attaining the same design.

2.3. Components

The following is a register of elements used to shape up our robot;

2.3.1. Arduino Micro-processor

Needing something to control our framework and go about as the head or the thinking mind about our framework so any kind of chip would work. We can discover numerous kinds of smaller-scale processors like the Arduino Uno with its various adaptations and the Raspberry pi moreover. In my

cooling framework I can, on the other hand, decided to utilize the Arduino Uno to control the fan and to deal with all capacities and occupations. The Arduino Uno is one of the littlest smaller-scale processors on the planet and its development is extremely muddled as there are introduced pins with a particular number and furthermore a particular number of pucks all dependent on the capacity the Arduino Uno is utilized for (Guglielmetti J.L. et al., 1996; Hertzog P.E. et al., 2016). There are a ton of capacities for the pins as there is a pin for power another for info and one for simple, reset, yield, etc. I additionally need a programing language to have the option to program my chip and as a PC engineer, we know an immense programming dialect however the most widely recognized language for us is the C language and by the assistance of the IDE programming application, I will amass the task. Programming in the Arduino Uno is finished unequivocally in the joined progression condition (IDE). Successfully programmable is the best good choice of the chip contrasted and different microchips.



Figure 4 is the Arduino Uno installed in the project as the head, main controller.

2.3.2. Temperature Sensing Device

The Temperature Sensor LM35 series are precision integrated-circuit temperature devices with an output voltage linearly proportional to the Centigrade temperature. The LM35 device has an advantage over linear temperature sensors calibrated in Kelvin, as the user is not required to subtract a large constant voltage from the output to obtain convenient Centigrade scaling. The LM35 device does not require any external calibration or trimming to provide typical accuracies of $\pm 1/4^{\circ}\text{C}$ at room temperature and $\pm 3/4^{\circ}$ cover a full -55°C to 150°C temperature range.

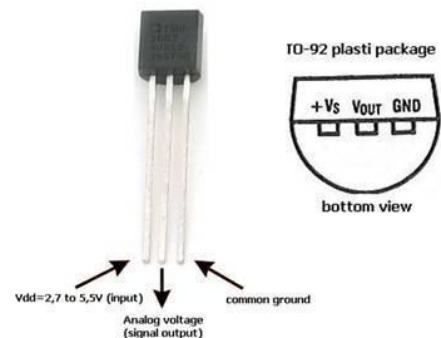

Figure 5. Temperature Sensing Device (LM35).

2.3.3. DC Fan (12V)

A fan is a powered machine used to create flow within a fluid, typically a gas such as air. A fan consists of a rotating arrangement of vanes or blades which act on the air. The rotating assembly of blades and hub is known as an impeller, rotor, or runner. Usually, it is contained within some form of housing or case (Buonocunto P. et al., 2016). This may direct the airflow or increase safety by preventing objects from contacting the fan blades. Most fans are powered by electric motors, but other sources of power may be used.



Figure 6. DC Fan (12V).

2.3.4. Potentiometer the Potentiometer

Potentiometer the potentiometer is a three-terminal resistor with a sliding or rotating contact that forms an adjustable voltage divider.

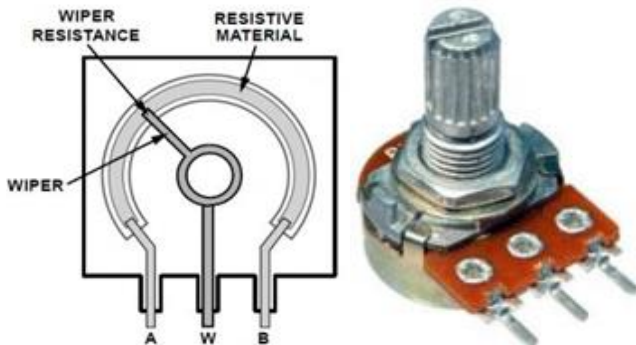

Figure 7. Potentiometer.

2.3.5. Jumper wires

Figure 8 shows a bundle of small cables named jumper wires. They possess connector pins at every end, granting them to be used to interface two points to one another without binding. These types of wires are regularly utilized with other prototyping instruments such like breadboards so as to make it uncomplicated to alter a circuit as desired. Genuinely it is straight-forward. Truth be told, it doesn't get considerably more fundamental than jumper wires.



Figure 8. A bundle of jumper wires.

2.3.6. LCD

An LCD is an electronic display module which uses liquid crystal to produce a visible image. The 16×2 LCD display is a very basic module commonly used in DIYs and circuits. The 16×2 translates to a display 16 characters per line in 2 such lines. In this LCD each character is displayed in a 5×7-pixel matrix.

2.3.7. Batteries

We must have a source of voltage and electrical energy to be converted into mechanical energy to be used in the movement of the robot. Two of any of the 9 volts batteries will be enough for our robot to work but we will bring two other batteries as a spare because the consumption of electrical power is high.



Figure 9. Batteries.

Shows a breadboard which is a solderless platform for brief mock-up with hardware and experiment circuit sketches. Many electronic elements in electronic circuits are to be interconnected by embedding their leads or terminals into the holes and then after that make connections through wires where proper. The breadboard has portions of metal underneath the board and interface the gaps on the surface points of the board. The metal strips are spread out as demonstrated. Notice how the surface and bottom row lines of the holes are associated horizontally on a level plane and split at the center as the rest of the gaps are associated vertically. Notice how all the holes in the chosen row line are associated together, so do the gaps in the chosen column section. The group of connected openings are known as nodes. To interlink the chosen row and column lines, node A and node B, a cable has to link from any gap in the row line to any gap in the column.

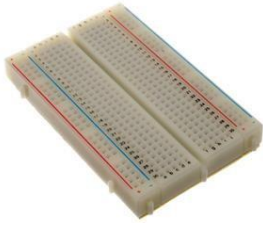

Figure 10. Breadboard.

2.3.8. LED

LEDs. An LED is a small light (it stands for "light emitting diode") that works with relatively little power.



Figure 11. LED.

2.3.9. Resistors

When building your Arduino projects, you use resistors to limit the amount of current going to certain components in the circuit, such as LEDs and integrated circuits. To calculate the resistance, you should use a modified version of Ohm's Law.

2.3.10. ESP8266MOD Node MCU Module (Wi-Fi)

Figure 13 is the Wi-Fi module termed ESP8266MOD. This specific Wi-fi module is a small chip used to connect the

robot with other devices to be allowed to command the robot through a computer or a mobile phone using a certain wizard. Here we are going to use ESP-8266-Wifi module. This type of Wi-Fi module is to be programed before with AT command set which is a well-known software so it will be easy to connect with our Arduino. The ESP8266 is prepared to do eit-



Figure 12. Resistors.

her the job of facilitating in hosting an application or offloading all Wi-Fi organizing capacities from an additional application processor hence it can act as a micro-controller enabling it to be correlated with the sensors and other application explicit devices via its GPIOs with negligible improvement in advance and insignificant stacking during runtime. Its high level of on chip joining considers negligible outside hardware, plus the front-end module, is intended to involve insignificant PCB region. The ESP8266 underpins APSD for VoIP applications and Bluetooth conjunction interfaces, it has a self-adjusted RF enabling it to work under every single working condition, and requires no outside RF parts. There is a practically boundless wellspring of data accessible for the ESP8266. The use of WiFi modules is widely increasing recently and is included in a lot of electronic fields.

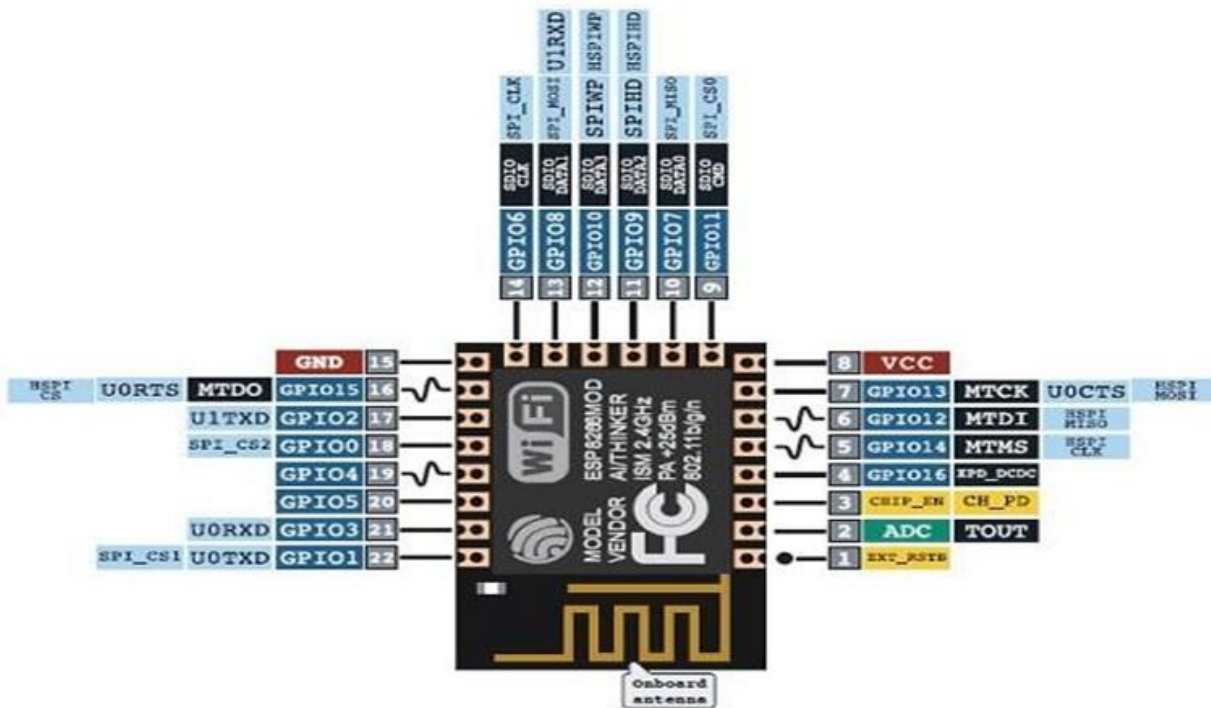

Figure 13. ESP8266MOD Node MCU Module.

2.4. System Model /Architecture

The framework formation of the system created utilizing the temperature sensor is provided in Figure 1, the cooling system device comprises of two methods of control in

particular the client control and automated control method for change of code and update to suit needs have given platform. This design will deliver a self-operating cooling system that can work efficiently and fulfil users need inside specific limits.

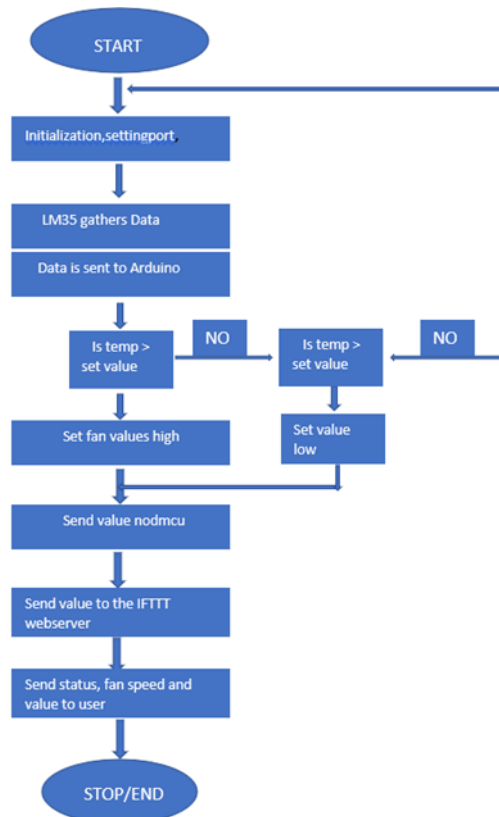

Figure 14. Model of the system design.

2.5 Material and Method

This chapter, is going to provide details of all the work that has been done leading to the final design. Since the main subject can be made in different ways, this split through four different designs leading up to our final successfully working design (Appendix A.1). The mechanical design is the first step of the project.

Figure 15 shows the method of connecting the dc motors to the motor shield (L294D specifically) to the Arduino and the wheels used in the robot movement. This design can take in up to twelve volts and has a local voltage controller aboard which yields five volts, the ideal sum for fueling our Arduino (Boxall J. 2021). One can connect everything as indicated by the Figure 15 above. Nevertheless, with four engine motors, we can at present get this design to turn toward any path by causing the two sides to go in inverse ways. The red and black wires are for power with the red ones as taking current from the positive terminal of the battery whilst the black wires are grounded with the negative terminal. Therefore, power is supplied to the Arduino module, all the DC motors and the L293d shield. In Figure 1 (a), the Bluetooth module connections to the Arduino are shown (Zhengyan W. et al., 2011). In any kind of Arduino project which utilizes this kind of module, these connections (Arduino to Bluetooth module) never change. The GND and VCC pins on the module are always connected to the GND pin and 5 Volts pin respectively

on the Arduino. The TX and RX pins on the Arduino are connected to the RX and TX pins respectively on the module. Figure 15 is the Arduino to Ultrasonic connections. In this case, the Trig and Echo pins of the sensor are connected to the Analogue pin zero (A0) and Analogue pin one (Badamasi Y.A. 2014).

(A.1) respectively on the Arduino. Just like the Bluetooth module, the sensor’s power pins (VCC and GND) are to be linked to the 5 Volts pin and GND pin on the microcontroller. The servo motor is additionally utilized in this design. The sensor is mounted on the servo and by turning the motor to various turns, we will get the readings from the ultrasonic sensor in those direction of turns. This will assist the operator with detecting the definite pathway to explore (Haidar A.M. et al., 2013). The design is set to operate in two modes, the Bluetooth controlled mode (or manual control) and automated mode (capable of obstacle hindrance innovation). On the same robotic body is a phone in camera mode with its interface being screened on a personal computer or laptop. There will be an external radar that will help to map the environment of our robot car. Our robotic vehicle is comprised of an Arduino Uno, Arduino motor L293D shield, Bluetooth module, 9 Volts or 12 Volts battery (preferably rechargeable), Direct Current motors, Ultrasonic sensor HC-SR04, HC-06 Ultrasonic Sensor working standard and an on-board camera (Feng C. et al., 2021). Temperature sensor LM35 senses the temperature and converts it into an electrical

(analog) signal, which is applied to the ATmega328 microcontroller of the Arduino UNO Board. The analog value is converted into a digital value (Liu C. et al., 2011). Thus the sensed values of the temperature and speed of the fan are displayed on the LCD. When the temperature exceeds 30°C the fan starts rotating. A low-frequency pulse-width

modulation (PWM) signal, whose duty cycle is varied to adjust the fan's speed is used. An inexpensive, single, small pass transistor-like 2N222 or BD139 can be used here. It is efficient because the pass transistor is used as a switch (Burke W. et al., 2009).

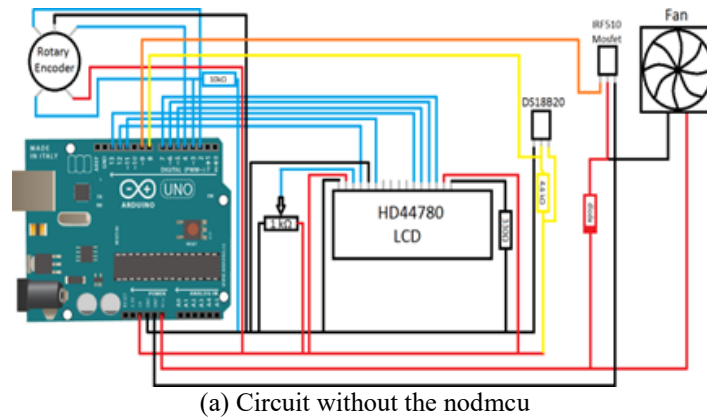

Figure 15. The connections and the Design.

3. RESULT AND DISCUSSION

3.1. Code/Program

Our radar system's code will be in A.2. The code and explanations for the two mode controlling will be in A.3. The algorithm flowchart for the Arduino Bluetooth RC Car application is shown in Figure 3, however. The entire circuit was put up and tested using various codes on several occasions. The creation and implementation of an auto cooling system was the main objective of this project. As was previously said, the entire project was tested, and the results were given, however every system eventually needs an upgrade or enhancement for improved performance. This chapter will detail the project's test findings.

Some data sets are needed to test the techniques and code employed in order to validate the work that was done. I came to a sound conclusion on the effectiveness of the codes and algorithms utilized thanks to the data set I used. In this project, one of the data sets was utilized to build a fairly straightforward perfuming cooling system. I had to do research and watch as many test videos as I could from other individuals to be able to view different versions with varied performance and results in order for me to be able to acquire a temperature sensor model that's very effective. After dividing the dataset into testing data and outcomes, the model was built using the data that had been gathered.

3.2. Testing and Results

There was a 50/50 possibility that I would get excellent or negative results while testing the models based on various setups and codes. I initially tried to check the code's output and got a respectable accuracy of roughly 0.5. Testing accuracy of roughly 76% was archived following a second

run of the model and changes to some of the parameters and codes.

4. CONCLUSION

Robotization systems are on show in light of the home connection being researched. Examining the microcontroller, user interface, communication interface, and display factor. There are several do-it-yourself (DIY) platforms that enable the creation of Home Automation structures rapidly, viably, and flawlessly, such as the Raspberry Pi, Arduino, various microcontrollers, etc. This review clarified many homes computerization structures, including electronic, cloud-based, Internet-based, email-based, Bluetooth-based, adaptable-based, SMS-based, ZigBee-based, Dual Tone Multi Frequency-based, and so on. In the future, home automation will be consistently fast and crisp. In places like schools, workplaces, manufacturing factories, etc., it is encountered on an immense scale We could have used the TMP36 sensor or the DHT sensor, but the LM35 is at least 0.25 degrees Celsius accurate and this is great for a project like this. As a result, the new system is relatively inexpensive because the components were carefully picked and are highly accessible. However, it needs some time to cool down before it can measure the surroundings' shifting temperatures.

5. APPENDIX

Appendix 1. First Failed Design and Its Source Code

Our first attempt to make the robot had the following scheme in "Figure A1".

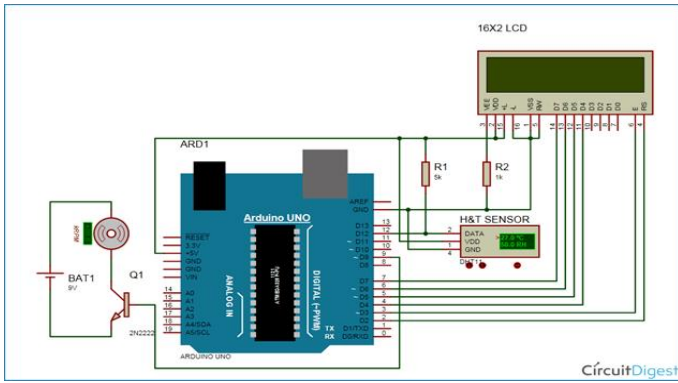

Figure A1. Failed design.

```
#include
//source: https://www.electroschematics.com/9540/arduino-fan-speed-controlled-temperature/
LiquidCrystal lcd(7,6,5,4,3,2);
int tempPin = A1; // the output pin of LM35
int fan = 11; // the pin where fan is
int led = 8; // led pin
int temp;
int tempMin = 30; // the temperature to start the fan
int tempMax = 70; // the maximum temperature when fan is at 100%
int fanSpeed;
int fanLCD;

void setup() {
  pinMode(fan, OUTPUT);
  pinMode(tempPin, INPUT);lcd.begin(16,2);
}

void loop() {
  temp = readTemp(); // get the temperature
  if(temp < tempMin) { // if temp is lower than minimum temp
    fanSpeed = 0; // fan is not spinning
    digitalWrite(fan, LOW);
  }
  if((temp >= tempMin) && (temp <= tempMax)) { // if temperature is higher than minimum temp
    fanSpeed = map(temp, tempMin, tempMax, 32, 255); // the actual speed of fan
    fanLCD = map(temp, tempMin, tempMax, 0, 100); // speed of fan to display on LCD
    analogWrite(fan, fanSpeed); // spin the fan at the fanSpeed speed
  }
  if(temp > tempMax) { // if temp is higher than tempMax
    digitalWrite(led, HIGH); // turn on led
  } else { // else turn of
    digitalWrite(led, LOW);
  }

  lcd.print("TEMP: ");
  lcd.print(temp); // display the temperature
  lcd.setCursor(0,1); // move cursor to next line
  lcd.print("FANS:");
  lcd.print(fanLCD); // display the fan speed
  speedLcd.print("%");
  delay(200);
  lcd.cle

int readTemp() { // get the temperature and convert it to celsius
  temp = analogRead(tempPin);
  return temp * 0.48828125;
}
```

Figure A2. Source code.

We connected all the dc motors and we made them face the same direction. We connected the box of the batteries into the downside of the chassis, then we went on to use a motor shield or a H bridge to connect the motors with the Arduino. As each side motors will be connected together so as to be controlled as one motor because the controller of the motor can only control three motors at the maximum level.

Appendix 2. Set Up and the Code

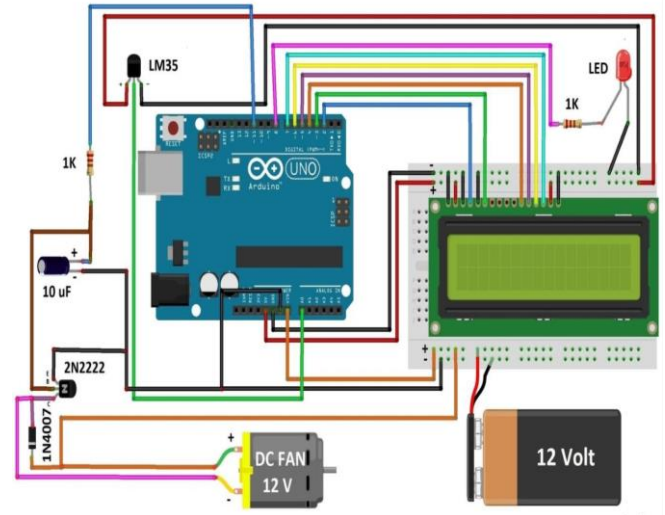

Figure A3. The connection chart of chosen alternative.

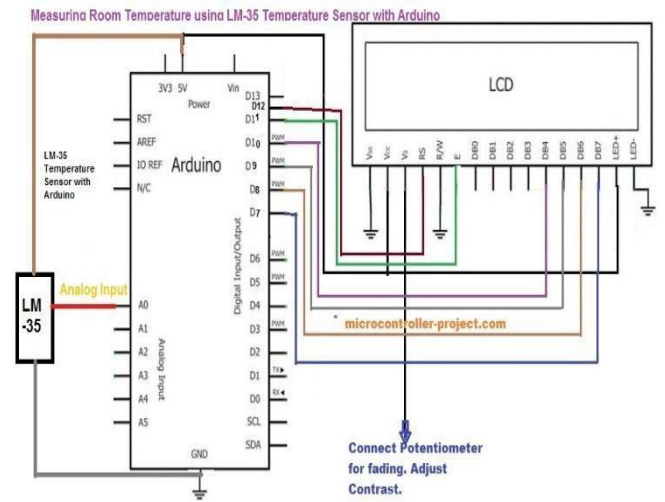

Figure A4. The picture of our design.

Appendix 3. Arduino Code Full Code

```

#include <LiquidCrystal.h>
LiquidCrystal lcd(2,3,4,5,6,7);
int tempPin = A0; // the output pin of LM35
int fan = 11; // the pin where fan is
int led = 8; // led pin
int temp;
int tempMin = 30; // the temperature to start the fan 0%
int tempMax = 60; // the maximum temperature when fan is at 100%
int fanSpeed;
int fanLCD;

void setup()
{
  pinMode(fan,
  OUTPUT);pinMode(led,
  OUTPUT);
  pinMode(tempPin, INPUT);
  lcd.begin(16,2);
  Serial.begin(9600);
}

void loop()
{
  temp = readTemp(); // get the temperature
  Serial.print( temp );
  if(temp < tempMin) // if temp is lower than minimum temp
  {
    fanSpeed = 0; // fan is not spinning
    analogWrite(fan, fanSpeed);
    fanLCD=0;
    digitalWrite(fan, LOW);
  }
  if((temp >= tempMin) && (temp <= tempMax)) // if temperature is higher than minimum temp
  {
    fanSpeed = temp;//map(temp, tempMin, tempMax, 0, 100); // the actual speed of fan/map(temp,
    tempMin, tempMax, 32, 255);
    fanSpeed=1.5*fanSpeed;
    fanLCD = map(temp, tempMin, tempMax, 0, 100); // speed of fan to display on LCD100
    analogWrite(fan, fanSpeed); // spin the fan at the fanSpeed speed
  }

  if(temp > tempMax) // if temp is higher than tempMax
  {
    digitalWrite(led, HIGH); // turn on led
  }
  else // else turn of led
  {
    digitalWrite(led, LOW);
  }

  lcd.print("TEMP: ");
  lcd.print(temp); // display the temperature
  lcd.print("C ");
  lcd.setCursor(0,1); // move cursor to next line
  lcd.print("FANS: ");
  lcd.print(fanLCD); // display the fan speed
  lcd.print("%");
  delay(200);
  lcd.clear();
}

int readTemp() { // get the temperature and convert it to celsius
  temp = analogRead(tempPin);
  return temp * 0.48828125;
}

```

Figure A5. Arduino Design SOURCE CODE.

6. REFERENCES

- Badamasi Y.A. (2014). 11th international conference on electronics, computer and computation ICECCO IEEE, 1-4.
- Boxall J. (2021). Arduino workshop: A Hands-On introduction with 65 projects. No Starch Press, Place, Published.
- Buonocunto P., Biondi A. and Lorefice P. (2014). in Proceedings of the 9th IEEE International Symposium on Industrial Embedded Systems SIES IEEE, 1-4.
- Buonocunto P., Biondi A., Pagani M., Marinoni M. and Buttazzo G. (2016). in Proceedings of the 31st Annual ACM Symposium on Applied Computing, 1724-1731.
- Burke W. and Auslander D. (2009). in International Design Engineering Technical Conferences and Computers and Information in Engineering Conference, 291-297.
- Feng C., Wang X., Li Z., Lin W., Ji H. and Shen S. (2021). in Journal of Physics: Conference Series IOP Publishing, 012028.
- Guglielmetti J.L., Chien C.J.H. and WASTES I. (1996). Containment Technology and Industry's Approach. 28, 127-133.
- Haidar A.M., Benachaiba C. and Zahir M. (2013). Software interfacing of servo motor with microcontroller.
- Heimerdinger W.L. and Weinstock C.B. (1992). Carnegie-Mellon Univ Pittsburgh Pa Software Engineering Inst.
- Hertzog P.E. and Swart A.J. (2016). IEEE Global Engineering Education Conference EDUCON IEEE, 66-73.
- Liu C., Ren W., Zhang B. and Lv C. (2011). in Proceedings of 2011 International Conference on Electronic & Mechanical Engineering and Information Technology IEEE, 1825-1828.
- Restuccia F., Pagani M., Mascitti A., Barrow M., Marinoni M., Biondi A., Buttazzo G., Kastner R. (2022). ARTe: Providing real-time multitasking to Arduino. 186, 111185.
- Stonebraker M. and Çetintemel U. (2018). " One size fits all" an idea whose time has come and gone, Place, Published, 441-462.
- Yuan D., Luo Y., Zhuang X., Rodrigues G.R., Zhao X., Zhang Y., Jain P.U. and Stumm M. (2014). in 11th USENIX Symposium on Operating Systems Design and Implementation OSDI 14, 249-265.
- Zhengyan W., Wei Y., Xingling S. and Hongqiang Z. (2011). Third International Conference on Measuring Technology and Mechatronics Automation IEEE, 911-914.