

APPLICATIONS OF BIN PACKING MODELS THROUGH THE SUPPLY CHAIN

Ugur ELIYI

Dokuz Eylul University,
Tinaztepe Campus, 35160 Izmir, Turkey
E-mail: ugur.eliyi@ogr.deu.edu.tr

Deniz Tursel ELIYI

Izmir University of Economics,
Sakarya Caddesi, No:156, 35330 Izmir, Turkey
e-mail: deniz.eliyi@ieu.edu.tr

—Abstract—

The Bin Packing Problem is defined as the placement of a set of different-sized items into identical bins so that the number of bins used is minimized. Specific cases of the problem vary according to the dimensions of items/bins, priority and placement constraints, and the planning horizon. The problem has important applications in Supply Chain Management, including vehicle, container, pallet or cargo loading, cutting stock and trim loss problems, packaging design, resource allocation, load balancing, scheduling, project management and financial budgeting. This study reviews various bin packing models, solution approaches, and several applications through different stages of the supply chain.

Key Words: *Bin Packing Problem, Optimization, Supply Chain Management.*

JEL Classification: C61

1. INTRODUCTION

A supply chain contains numerous different activities performed by various agents in different stages of procurement, transportation, production, distribution and storage. Therefore, the problem of managing a supply chain is a tedious job, involving many intricate subproblems. In most cases, the efficient and satisfactory solution to one of the subproblems requires a trade-off somewhere in the supply chain, meaning that another agent has to bear with a probably non-efficient solution to his subproblem.

As an example, if a supplier always tries to maximize his own profit, the commitment to a single-sourcing supply chain system may be suboptimal for him, since the utility of the facility may be below the desired level at some times. However, this decision may optimize the lead time and inventory levels when the whole system is considered. This example is just one of the many illustrating the fact that decisions in a supply chain require compromises from almost all acting parties. In centralized supply chain systems, these problems are solved centrally by a single decision maker considering the welfare of the whole system; while in decentralized chains, the

acting parties may have some freedom in determining their own solutions considering their isolated subsystems.

Centralized or decentralized, the many decisions in a supply chain, starting from sourcing, procurement and ending in distribution and storage has to be made sequentially most of the time, since the operations are dynamic and complicated.

The field of operations research (or management science), pursuing a scientific approach to decision making, aims to determine how best to design and operate a system under scarce resources. In this study, we examine a popular problem in operations research, namely the Bin Packing Problem (BPP), which may be of great help in answering critical questions in the field of supply chain management. Although the problem is well-known and well-studied analytically, it has not lost its attraction through the decades. In a supply chain, many decisions including vehicle and container loading, cutting stock, packaging design, resource allocation, project management and financial budgeting can be made through the use of algorithms developed for solving different variants of the BPP.

In the basic BPP, objects of different volumes must be packed into a finite number of bins of capacity V in a way that minimizes the number of bins used. Closely related problems are knapsack and cutting stock problems. In the next section, we provide the basic mathematical formulation of the problem, and review its variants. Some techniques for obtaining optimal or approximate solutions will be overviewed. We provide several supply chain applications to the problem in the third section. We present a summary and discussion in the final section.

2. THE BIN PACKING PROBLEM

In section 2.1, we provide the mathematical formulation of the basic BPP. The problem has variants including one, two, three or four dimensions, which will be reviewed in section 2.2, together with various solution approaches from the literature. Similar problems from the same family, namely knapsack and cutting stock problems will be discussed in section 2.3.

2.1. Problem Definition

BPP can be defined as follows: We have several containers or bins (of the same size), and we wish to pack n items in as few containers as possible. The BPP is an NP-hard problem (Garey and Johnson, 1979). The problem is modeled with the use of binary indicator variables.

The mathematical formulation of the problem is as follows:

$$\text{Minimize } z = \sum_{j=1}^n y_j \text{ subject to:} \quad (1)$$

$$\sum_{j=1}^n v_j x_{ij} \leq V_i y_i \quad 1 \leq i \leq m \quad (2)$$

$$\sum_{i=1}^n x_{ij} = 1 \quad 1 \leq j \leq n \quad (3)$$

$$x_{ij}, y_i \in \{0,1\} \quad 1 \leq i \leq m, 1 \leq j \leq n \quad (4)$$

The objective function in (1) tries to minimize the total number of bins that are used for packing all items. The variable y_i takes the value of 1 if bin i is used for storage, otherwise it takes the value zero. Constraint set (2) ensures that the bin capacity is not exceeded for any bin. The variable x_{ij} is 1 if item j is packed in bin i , zero otherwise. Constraint set (3) sets that all items should be packed. Finally, constraint set (4) ensures binary variables.

This formulation of the BPP is also known as the one-dimensional or the basic bin packing problem. The problem has many applications including the loading of containers, loading trucks with weight capacity, or creating file backup in removable media. The problem also has many realizations in manufacturing environments.

Since the problem is NP-hard, obtaining an optimal solution is very time consuming, and in most of the cases not preferred for this reason especially for large instances. Therefore, the most of the popular efficient algorithms use heuristic procedures to obtain approximate solutions, which provide nice suboptimal values. As an example, the first fit algorithm generates a good (though non-optimal) solution very quickly through placing each item into the first bin in which it will fit. Obtained from first fit algorithm, best fit algorithm assigns each item to a feasible bin having the smallest residual capacity. Johnson et al. (1974) showed that these algorithms can differ from an optimal packing by at most 70%. Sorting the items in nonincreasing order of their sizes, and then applying the mentioned algorithms improves the asymptotic performance to 22.2% despite the increase in time complexity due to the sorting procedure.

Branch and Bound technique is an optimization technique used for the exact solution of BPP, as other problems in operations research. The branch and bound method performs an implicit enumeration of all the feasible solutions of the problem, generally using some approximation algorithms and lower bounds for obtaining more efficient solutions. Similarly, dynamic programming is another method for the optimal solution of the problem. Both of these approaches, together with reduction procedures concerning the feasible solution space, may become effective depending on the specific features of the items and the bins.

For interested readers of this area, Skiena (1998) presents an extensive review on the BPP and developed approximation algorithms.

Variations of the BPP include two, three and four-dimensional BPP, with additional constraints pertaining to positioning of items in the bins, bin shapes, or fuzzy information, which will be reviewed in the next section.

2.2. Variants of the Bin Packing Problem

A two-dimensional bin packing problem is involved with packing various-sized items of different geometrical shapes into fixed sized, two-dimensional bins, using as few of the bins as possible. Most commonly, the shapes of items and containers are taken as rectangles, which is not far from being realistic. This problem is harder than the one-dimensional problem, as expected; since the 1-D BPP is NP-hard, the 2-D BPP is NP-hard, also.

The 3-D BPP is closely related to other three-dimensional loading problems, such as knapsack loading and container loading. Naturally, it finds many industrial applications like packaging, mechanical and electrical design, vehicle and pallet loading, loading area, multiprocessor scheduling, task assignment, and several scheduling problems.

In the knapsack loading of a container each item has an associated profit, and the problem is to choose a subset of the items that fits into a single container (bin) so that maximum profit is loaded. If the profit of an item is set to its volume, this corresponds to the minimization of wasted space. In the container loading version, all the items have to be packed into a single bin, having an infinite height. The problem is thus to find a feasible solution that minimizes the height to which the bin is filled.

In general, the complexity of a specific BPP is dependent on the shapes and sizes of the items to be packed, and the containers to hold the items. While in 1-D BPP, the size of an item is represented by a single integer number, in 2-D BPP the size and shape performs a large role in packing. In 3-D BPP, the volume of the item and the positioning or orientation brings further complexity. For example, in loading a truck, boxes labeled as "this side up" require a certain orientation, restricting flexibility in packing and most likely increasing the optimal number of bins. Similarly, boxes with delicate objects may be labeled as "do not stack" and thus are to sit on top of a pile of boxes, taking into account load bearing strengths of the items (Bischoff, 2006). Furthermore, balancing conditions and weight distribution of the placed items should be considered in most real-life cases. Each of these different variants of the problem may be online or offline, depending on whether the complete set of objects that will be packed are known at the start or not.

Another variation includes rejection penalties for unpacked items, where not all items have to be packed. An item can be either unpacked, in which case its rejection penalty is paid, or put into one bin provided that the total load of the bin does not exceed 1. No item can be divided between bins. The objective is to minimize the total number of used bins plus the total penalty paid for the rejected items (Dósa and He, 2006). The authors of this problem present an approximation algorithm.

Several real-life situations require alternative admissible solutions, taking into account the decision maker's priorities. Similar to the multi-objective decision approaches, sources of fuzziness are to be determined, and should be employed for quick and nice solutions. A previous study defines fuzzy bin packing as a problem of packing non-rigid rectangles into an open rectangular bin (Kim et al., 2001). The goal of the authors is to minimize both the height of a packing and the extra cost due to the size reduction of each piece. Nasibov (2004) considers a new statement of the bin packing problem with the evaluation of the packing quality under fuzzy source constraints, developing a finite interactive algorithm for the solution. He defines fuzzy relations between the items and the containers, so that the decision maker can impose certain constraints on the placement of items. These relations reflect degree of mutual attachment and mutual compatibility between items and containers.

It is often observed in the literature of 2-D and 3-D BPP that, new lower bounds are defined by comparing their performances and dominance relations with the previous ones and each other, and worst-case analysis of these bounds are examined. In one such study, an exact algorithm for

selecting a subset of items that can be packed into a single bin by maximizing the total volume packed (see Figure-1) is developed (Martello et al., 2000). They use their lower bound definitions to implement two approximation algorithms and an exact branch-and-bound algorithm.

Fekete and Schepers (2004), present a new approach using a graph-theoretical characterization of feasible packings. Their characterization allows us to deal with classes of packings that share a certain combinatorial structure, instead of having to consider one packing at a time. Using elegant algorithmic properties of certain classes of graphs, the characterization becomes the basis for a successful branch-and-bound framework.

In many studies, metaheuristics approaches for the problem are employed. In a very recent study, a two-level tabu search is presented, the first-level of which aims to reduce the number of bins, and the second optimizes the packing of the bins (Crainic et al. 2009).

Figure-1: Single bin filling in 3-D Bin Packing Problem

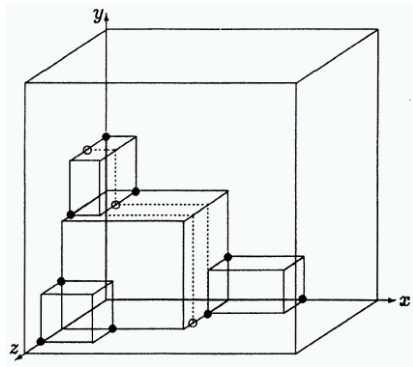

Source: Martello et al., 2000: 261.

2.3. Knapsack and Cutting Stock Problems

Very similar to the BPP are the knapsack and cutting stock problems, which will be briefly reviewed in this section. In the NP-hard knapsack problem (Garey and Johnson, 1979), we have one knapsack of volume V and n items, having different sizes (volumes) and values (weights). The objective is to determine which of the items should be placed in the knapsack so as to maximize the total value without exceeding the total volume of the knapsack. The name derives from the scenario of choosing treasures to fit inside a knapsack when one can only carry limited weight. The knapsack problem, coming from the same family of problems as the BPP, is a very popular problem in operations research, due to its broad area of practical applications.

Numerous versions to the knapsack problem include the unbounded knapsack problem, the bounded knapsack problem, and the 0-1 knapsack problem. In the unbounded problem, the main feature is that there are m types of items, and the number of items from each type is unlimited. Hence, as long as there is room in the knapsack, many items from the same type may be packed in. In the bounded problem, there are bounds on the size of each type. So the number of items that can be stored in the knapsack is limited for each type. The 0-1 knapsack problem is another special

case, which restricts the number of each type of item to zero or one. Another variation is the fractional knapsack problem, which assumes that fractional amounts of items can be stored in the knapsack. A greedy algorithm finds the optimum solution for this problem. The algorithm packs as much as possible of the most valuable item per unit volume as long as there is room in the knapsack.

Knapsack problem has been studied extensively in literature. The problem is especially studied for fixed-dimension containers. Pisinger (2002) has considered the container loading problem. The problem is loading a subset of rectangular boxes into a rectangular container of fixed dimensions such that the volume of the packed boxes is maximized. The author has proposed a new heuristic for the suboptimal solution of the problem. Brunetta and Grégoire (2005) have presented a fast and efficient heuristic algorithm for solving a large class of three-dimensional knapsack problems.

Cutting stock problem arises in a variety of manufacturing problems. Suppose that you are manufacturing widgets with parts cut from sheet metal, or pants with parts cut from cloth. To minimize cost and waste, the parts should be laid out so as to minimize the number of fixed-size metal sheets or bolts of cloth. Identifying which part goes on which sheet in which position is a bin-packing variant called the cutting stock problem. After the products have been successfully manufactured, another bin packing problem of loading onto trucks the boxes of items will be encountered (Skiena, 1998). The cutting stock problem is in fact identical to the bin packing problem, but since practical instances usually have far fewer types of items, another formulation is used for the problem.

Single stock-size cutting include the 1-D Cutting Stock Problem (Gilmore and Gomory, 1963; Wäscher and Gau, 1996), where a standard material of a specific, single length has to be cut down into a set of ordered lengths (small items). In the 2-D problem, a set of ordered rectangles has to be cut from stock sheets of specific length and width.

Since the cutting stock problem is identical to the BPP, but with fewer types of items, the techniques developed for the solution of the BPP can be applied to this problem, as well.

3. APPLICATIONS OF THE BPP THROUGH THE SUPPLY CHAIN

In this section, we go over some functions of the supply chain to identify application areas for the BPP, in addition to the ones presented in the previous sections. Interestingly, many decisions from different functional areas can be modeled and solved as variations of the BPP, as it will be stated below.

3.1. Production

This is one of the most obvious stages in a supply chain, where the BPP can find its applications. As it was stated in the previous sections, the cutting stock problem has direct implementations in manufacturing or service environments in different industrial sectors.

Applications in this stage are often found in stock cutting or trim loss examples, where quantities of material such as glass or metal, are produced in standard sized, rectangular sheets. Orders for pieces of the material are for rectangles (or other shapes) of arbitrary sizes. The problem is to use the minimum number of standard sized sheets in meeting orders. For instance, suppose a number

of pipes of different lengths are required for plumbing a house, and pipe stock is available in 5 meter lengths. How can we cut the 5 meter pipes to waste as little as possible (minimize the cost of pipe)? In trim loss problems, the objective is to minimize wasted material from these sheets.

Another application is the tiling problem. Using a fixed-dimension tile, the objective is the maximization of the amount of floor space that can be covered. The cookie cutter problem is an application from the service sector. This problem deals with maximizing the number of cookies you can cut from a given expanse of dough (Hoffman, 1998). The cookie cutter problem can also be applied to the manufacturing environments where resource allocation is a critical problem.

Assembly line balancing or load balancing is another application of the BPP in a different context. Here, the goal is to balance the workloads of workstations along an assembly line, trying to minimize the production cycle time and the number of workstations. This problem resembles the BPP since many different activities are tried to be loaded on machines in such a manner that the total time of the activities on a machine cannot exceed a prespecified target cycle time. The number of workstations are to be kept at minimum.

Other application areas of some variants of the BPP in the production stage include the assignment of tasks to personnel, and scheduling of different tasks and resources.

3.2. Distribution & Inventory

There are numerous applications of the BPP in this stage of the supply chain, some of which are identified in the previous sections such as truck and container loading. The items are often of various sizes and shapes, and certain orientation and positional constraints are present. Some items may require special technological conditions to be transported (such as a specific temperature level), and some items may call for spherical containers. The weight distribution over the pallet or the stability aspects regarding the container may be considered. Application examples from this stage include the Multi-Pallet Loading Problem (Terno et al., 2000) and the Multi-Container Loading Problem (Scheithauer, 1999), in which a set of boxes is to be packed on a minimum number of pallets or into a minimum number of containers maximizing space utilization.

As another interesting application, Schumann et al. (2005) presented the potted plant packing problem as a variation of a bin packing problem. In this problem, the plants are packed on standardized trolleys for transportation, with transport costs being directly dependent upon the number of trolleys used. As a result, the effective packing of trolleys is an important practical problem.

Design of packaging is another application area for the BPP. The success of IKEA in minimizing inventory space is attributed to its clever “flat” package designs. This example demonstrates the fact that, instead of trying to store predetermined size and shape packages in a fixed area of storage, the decision makers of the supply chain may come up with optimal designs for packaging of items in order to maximize space utilization.

3.3. Other Functions

Project scheduling is an issue in all stages of a supply chain. It is concerned with the efficient utilization of given resources (time, people, budget) to complete a sequence of activities, which

have precedence relations among themselves. Obviously, the decision makers in all stages of the supply chain, starting from suppliers' tier reaching to the customers', have to deal with their own projects.

Project scheduling resembles the BPP in many aspects. The problem of task allocation along a timeline can be modeled and solved as a multi-dimensional BPP. The specific algorithms developed for the BPP may be adapted effortlessly, in this case.

Financial budgeting is another general problem in supply chains, which deals with resource allocation. The characteristics of this problem are very similar to the knapsack problem, where a certain amount of monetary budget is to be distributed among a number of activities having different costs. Considering this resemblance, one can benefit from the solution procedures for the knapsack problems in managing long and short term cash flows.

4. SUMMARY AND CONCLUSION

In this study, we review the Bin Packing Problem, which is defined as the placement of a set of different-sized items into identical bins so that the number of bins used is minimized. We present the problem, mathematical model, some variants and solution procedures.

The problem has important applications in supply chains in many different contexts, ranging from container loading to financial budgeting decisions. We briefly review these application areas, in which solution procedures to the BPP may be of great help.

Like BBP, many other popular problems in operations research have a great many application areas. However, the practitioners in the industry are not usually aware of the advantages that the accumulated theory in operations research may bring to their practices. Another setback is that the practitioners cannot relate their problems to the existing and well-known models with ready solution approaches. Our study points out to the decision makers in various stages of a supply chain that, once this information lag is overcome, advances may be achieved. In particular, adapting BPP to their environments may produce more profitable outcomes, even for their very specific systems.

BIBLIOGRAPHY

- Bansal, Nikhil, Jose R. Correa, Claire Kenyon and Maxim Sviridenko (2006), "Bin packing in multiple dimensions: inapproximability results and approximation schemes", *Mathematics of Operations Research*, Vol. 31, pp. 31-49.
- Bischoff, E.E. (2006), "Three-dimensional packing of items with limited load bearing strength", *European Journal of Operational Research*, Vol. 168, No. 3, pp. 952-966.
- Crainic, Teodor G., Guido Perboli and Roberto Tadei (2009), "TS²PACK: A two-level tabu search for the three-dimensional bin packing problem", *European Journal of Operational Research*, Vol. 195, No. 3, pp. 744-760.
- Dósa, G., Y. He, (2006), "Bin packing problems with rejection penalties and their dual problems", *Information and Computation*, Vol. 204, No. 5, pp. 795-815.

Fekete, Sandor P. and Jörg Schepers (2004), "A combinatorial characterization of higher-dimensional orthogonal packing", *Mathematics of Operations Research*, Vol. 29, No. 2, pp. 353-368.

Garey, Michael R., David S. Johnson (1979), *Computers and Intractability: A Guide to the Theory of NP-Completeness*, New Jersey: W.H. Freeman.

Gilmore, P.C. and R.E. Gomory (1963), "A linear programming approach to the cutting-stock problem part II", *Operations Research*, Vol. 11, pp. 864-888.

Hoffman, P. (1998), *The Man Who Loved Only Numbers: The Story of Paul Erdos and the Search for Mathematical Truth*, New York: Hyperion.

Johnson, David S., A. Demers, J.D. Ullman, M.R. Garey and R.L. Graham (1974), "Worst-case performance bounds for simple one-dimensional packing algorithms", *SIAM Journal on Computing*, Vol. 3, pp. 299-325.

Kim, Jong-Kyou, H. Lee-Kwang and Seung W. Yoo (2001), "Fuzzy bin packing problem", *Fuzzy Sets and Systems*, Vol. 120, No. 3, pp. 429-434.

Martello, Silvano and Paolo Toth (1990), *Knapsack Problems: Algorithms and Computer Implementations*, Chichester: John Wiley & Sons.

Martello, Silvano, David Pisinger and Daniele Vigo (2000), "The Three-Dimensional Bin Packing Problem", *Operations Research*, Vol. 48, No. 2, pp. 256-267.

Nasibov, Efendi N. (2004), "An Algorithm for Constructing an Admissible Solution to the Bin Packing Problem with Fuzzy Constraints", *Journal of Computer and Systems Sciences International*, Vol. 43, No. 2, pp. 205-212.

Pisinger, David (2002), "Heuristics for the container loading problem", *European Journal of Operational Research*, Vol. 141, No. 2, pp. 382-392.

Scheithauer, Guntram (1999), "LP-based bounds for the container and multi-container loading problem", *International Transactions in Operations Research*, Vol. 6, pp. 199-213.

Schumann, R., J. Behrens and J. Siemer (2005), "The potted plant packing problem", (in: J. Sauer-Ed., *Workshop Plan, Scheduling und Konfigurieren/Entwerfen*), Koblenz: Universitat Koblenz-Landau Fachbereich Informatik.

Skiena, S.S. (1998), *The Algorithm Design Manual*, New York: Springer.

Terno, Johannes, Guntram Scheithauer, Uta Sommerweiß and Jan Riehme (2000), "An efficient approach for the multi-pallet loading problem", *European Journal of Operational Research*, Vol. 123, No. 2, pp. 372-381.

Wäscher, Gerhard and T. Gau (1996), "Heuristics for the Integer one-dimensional cutting stock problem: a computational study", *OR Spectrum*, Vol.18, pp. 131-144.