

## Design and Analysis of a Topology-Optimized Quadcopter Drone Frame

Berke BAY<sup>1</sup> , Meltem ERYILDIZ<sup>1\*</sup> 

<sup>1</sup>Istanbul Beykent University, Department of Mechanical Engineering, Faculty of Engineering and Architecture, Istanbul, Turkey

### Article Info

Research article  
Received: 19/06/2023  
Revision: 05/10/2023  
Accepted: 13/10/2023

### Keywords

Drone  
Drop test  
Topology Optimization  
FEA Analysis  
Flow Simulation

### Makale Bilgisi

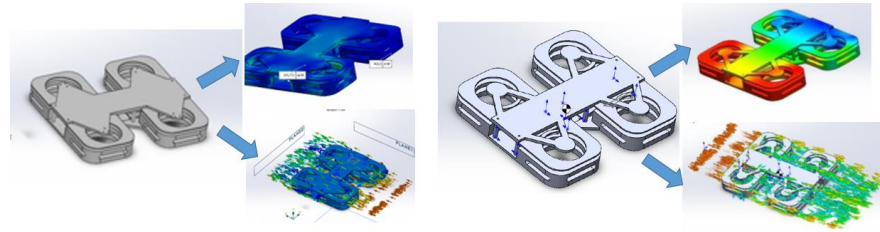
Araştırma makalesi  
Başvuru: 19/06/2023  
Düzeltilme: 05/10/2023  
Kabul: 13/10/2023

### Anahtar Kelimeler

Drone  
Düşme testi  
Topoloji Optimizasyonu  
FEA analizi  
Akış Simülasyonu

### Graphical/Tabular Abstract (Grafik Özet)

Three different drone frames were designed. The best design was chosen based on stress, displacement, and flow analysis results. Topology optimization was applied to achieve a 30% weight reduction for this design. Analyses were conducted on this optimized design to verify the results. / Üç farklı drone gövdesi tasarlanmıştır. Gerilme, uzama ve akış analizleri sonucunda en iyi tasarım seçilmiştir. Bu tasarıma yüzde 30 ağırlık azaltma amacıyla topoloji optimizasyonu uygulanmıştır. Ve bu tasarıma da analizler yapılarak sonuçlar kontrol edilmiştir.



**Figure A:** After the design phase, analyses were conducted, topology optimization was applied, and then analyses were performed again. /**Şekil A:** Tasarım aşamasından sonra analizler gerçekleştirilip topoloji optimizasyonu uygulanmış, ardından analizler yeniden gerçekleştirilmiştir

### Highlights (Önemli noktalar)

- Innovative drone design/ İnovatif drone tasarımı.
- Weight Reduction Through Topology Optimization/ Topoloji optimizasyonu ile ağırlık azaltma
- Enhancing drone frame design for Improved performance and reliability/ İyileştirilmiş performans ve güvenilirlik için drone gövde tasarımının geliştirilmesi

**Aim (Amaç):** The main aim of this study is to assess the potential of topology optimization in enhancing drone frame design, and to utilize finite element analysis (FEA) and topology optimization techniques to achieve an optimal design during the initial phase, ultimately leading to the construction of an ideal full-scale drone prototype. / Bu çalışmanın temel amacı, drone gövde tasarımını geliştirmede topoloji optimizasyonunun potansiyelini değerlendirmek ve başlangıç aşamasında en iyi tasarımı elde etmek için sonlu eleman analizi (FEA) ve topoloji optimizasyon tekniklerini kullanmak, sonuç olarak ideal bir tam ölçekli drone prototipi geliştirmektir.

**Originality (Özgünlük):** Addressing stress distribution, displacement, and aerodynamic performance to improve lightweight drone frame designs./ Birden fazla analizin kapsamlı bir şekilde entegre edilmesi, stres dağılımı, uzama ve aerodinamik performansı ele alarak sonuçta verimli ve güvenilir daha hafif drone teknolojisinin ilerlemesine katkıda bulunulması.

**Results (Bulgular):** Design 1 exhibited lower displacement values, suggesting better deformation resistance and outperformed in terms of flow velocity, indicating better propulsion and aerodynamic performance, particularly in Directions 1 and 2. Through topology optimization, a 30% weight reduction was achieved for Design 1, leading to improved agility, maneuverability, and energy efficiency./ Tasarım 1, daha iyi deformasyon direnci göstermiş ve akış hızı açısından özellikle Yön 1 ve 2'de daha iyi performans sergilemiştir. Tasarım 1 için topoloji optimizasyonu ile %30 ağırlık azaltması elde edilmiş, bu da daha iyi çeviklik, manevra kabiliyeti ve enerji verimliliği sağlamıştır.

**Conclusion (Sonuç):** This study's comprehensive analysis of drone frame designs highlights the potential for substantial improvements in structural integrity, aerodynamic performance, and weight reduction, paving the way for the development of more efficient and reliable drones in the future./ Bu çalışma, drone şasi tasarımlarının stres dağılımı, uzama, ağırlık azaltımı ve akış özelliklerinin dikkate alınmasının önemini vurgulayarak, drone çerçevelerinin tasarım ve optimizasyonu için değerli görüşler sunmaktadır.



## Design and Analysis of a Topology-Optimized Quadcopter Drone Frame

Berke BAY<sup>1</sup> , Meltem ERYILDIZ<sup>1\*</sup> <sup>1</sup>Istanbul Beykent University, Department of Mechanical Engineering, Faculty of Engineering and Architecture, Istanbul, Turkey

### Article Info

Research article  
Received: 19/06/2023  
Revision: 05/10/2023  
Accepted: 13/10/2023

### Keywords

Drone  
Drop test  
Topology Optimization  
FEA Analysis  
Flow Simulation

### Abstract

This study focuses on the analysis and optimization of a drone frame design to enhance its performance characteristics. The design underwent drop testing, stress analysis, displacement analysis, and flow simulation to evaluate its structural integrity, deformation resistance, and aerodynamic performance. Furthermore, topology optimization techniques were employed to achieve a 30% weight reduction while maintaining the structural integrity of the drone frame. The results of the drop test analysis revealed that Design 2 exhibited reduced stress levels, displaying a maximum stress reduction of 296% compared to Design 1, indicating improved load distribution and structural integrity. However, Design 1 demonstrated lower displacement values, with a maximum decrease of 46.48%, suggesting better resistance to deformation. The flow analysis indicated that Design 1 achieved lower flow velocities, with a maximum decrease of 6.21%, indicating superior propulsion and aerodynamic performance. Through topology optimization, the mass of the drone frame was successfully reduced by 30% without compromising structural integrity. The optimized design exhibited improved stress management, reduced displacement, and slightly higher flow velocities compared to the initial design. These improvements contribute to enhanced agility, maneuverability, and energy efficiency of the drone. The findings of this study highlight the importance of considering stress distribution, displacement, and aerodynamic performance in drone design and optimization. The results provide valuable insights for the development of efficient and reliable drones.

## Topoloji Optimizasyonu ile Bir Dört Rotorlu Drone Gövde Tasarımı ve Analizi

### Makale Bilgisi

Araştırma makalesi  
Başvuru: 19/06/2023  
Düzeltilme: 05/10/2023  
Kabul: 13/10/2023

### Anahtar Kelimeler

Drone  
Düşme testi  
Topoloji Optimizasyonu  
FEA analizi  
Akış Simülasyonu

### Öz

Bu çalışma, bir drone gövde tasarımının analizi ve optimizasyonuna odaklanarak performans karakteristiklerini artırmayı amaçlamaktadır. Geliştirilen tasarımlar, yapısal bütünlüğünü, deformasyon direncini ve aerodinamik performansını değerlendirmek için düşme testi, gerilim analizi, uzama analizi ve akış simülasyonlarına tabi tutulmuştur. Ayrıca, gövde tasarımının yapısal bütünlüğünü korurken %30 ağırlık azaltma hedefiyle topoloji optimizasyon teknikleri kullanılmıştır. Düşme testi analizi sonuçları, Tasarım 2'nin, Tasarım 1'e kıyasla gerilmelerde %296'lık bir azalma sergileyerek yük dağılımını ve yapısal bütünlüğü artırdığını göstermektedir. Ancak, Tasarım 1 %46.48 daha düşük uzama değerleri göstermiştir. Akış analizi, Tasarım 1'in daha düşük akış hızlarına ulaştığını, maksimum %6.21'lik azalma ile gelişmiş tahrik ve aerodinamik performans sergilediğini göstermektedir. Topoloji optimizasyonu sayesinde, drone gövde ağırlığı başarıyla %30 azaltılmış ve yapısal bütünlüğü korunmuştur. Optimizasyon sonucu tasarım, gerilme değerleri olarak daha gelişmiş, uzama değerleri azalmış ve başlangıçtaki tasarıma kıyasla biraz daha yüksek akış hızları sergilemektedir. Bu gelişmeler, dronun çevikliğini, manevra kabiliyetini ve enerji verimliliğini artırmaya katkı sağlamaktadır. Bu çalışmanın bulguları, drone tasarımı ve optimizasyonunda stres dağılımı, uzama ve aerodinamik performansın dikkate alınmasının önemini vurgulamaktadır. Sonuçlar, verimli ve güvenilir dronların geliştirilmesi için değerli bilgiler sunmaktadır.

## 1. INTRODUCTION (GİRİŞ)

Drones, also known as unmanned aerial vehicles (UAVs), have rapidly gained popularity in various fields, ranging from aerial photography and videography to surveillance, delivery services, and scientific research. Drones come in various shapes,

sizes, and configurations, catering to specific applications and requirements. One popular type is the quadcopter, which features four rotors arranged in a symmetric pattern, offering stability, maneuverability, and ease of control. Quadcopters are commonly used due to their versatility and

ability to hover, fly in tight spaces, and perform agile maneuvers. These versatile flying machines are revolutionizing industries by providing efficient and cost-effective solutions. As drone technology continues to evolve, there is a growing demand for lightweight and durable drone frames that can withstand rigorous flight conditions while maximizing performance and efficiency [1-3].

Topology optimization is a design approach that utilizes advanced algorithms to determine the optimal distribution of material within a given design space. By iteratively removing unnecessary material, topology optimization aims to enhance the structural efficiency and performance of a component while reducing its weight. This technique has gained significant importance in the design and manufacturing of drone frames [4]. The Importance of Topology Optimization for Drone Frames lies in its ability to maximize the strength-to-weight ratio, enhance structural integrity, and improve flight characteristics. By removing excess material from non-critical areas and redistributing it to areas experiencing high stress, topology optimization enables the creation of lightweight yet robust drone frames. This optimization process can significantly enhance the drone's flight performance, increase battery life, and improve payload capacity [5].

In literature, topology optimization has been used to design drone frames. In one study [6], researchers used topology optimization to design a 3D-printed quadcopter frame that was 20% lighter than a traditional frame. The optimized frame was also stronger than the traditional frame, and it had better flight performance. Nvss et al. [7] studied the design optimization and fabrication of a lightweight quadcopter frame using topology optimization, part consolidation, and additive manufacturing. The findings demonstrate that the re-engineered monocoque structure, manufactured through Fused Filament Fabrication (FFF), achieves weight reduction, improved structural integrity, and enhanced operational superiority and endurance compared to commercial UAV designs. Bright et. al [8] investigated the use of generative design tools to create a quadcopter frame, resulting in a frame with improved resistance to fracture, minimum displacement, and better performance compared to a traditionally designed DJI flame wheel F450 drone frame [4]. The literature demonstrates the successful application of topology optimization in designing drone frames, resulting in significant improvements. By utilizing topology optimization, researchers have created 3D-printed quadcopter frames that are lighter, stronger, and exhibit better

flight performance compared to traditional designs. While the existing literature demonstrates the successful application of topology optimization in designing drone frames, further research is needed to fully explore and validate the potential benefits.

Drone frame materials play a pivotal role in shaping the performance and durability of unmanned aerial vehicles. The selection of appropriate materials significantly influences factors such as weight, structural integrity, and maneuverability. Carbon fiber, renowned for its high strength-to-weight ratio, is a popular choice for constructing lightweight yet resilient frames. Aluminum alloys offer a balance between strength and cost-effectiveness, making them suitable for various drone applications. Additionally, innovative materials like graphene composites are emerging, promising even greater strength and conductivity. The evolution of drone frame materials reflects the ongoing pursuit of enhancing flight efficiency, endurance, and overall flight experience. ABS (Acrylonitrile Butadiene Styrene) is a notable contender in the realm of drone frame materials. Its blend of toughness, impact resistance, and ease of processing makes it a favored choice for constructing robust and durable drone frames. ABS frames offer good dimensional stability and can withstand diverse weather conditions, making them suitable for outdoor and versatile applications. With a balance between strength and affordability, ABS contributes to crafting cost-effective yet reliable drone structures that can withstand the demands of aerial operations. In this study, ABS was selected as the drone frame material due to its well-balanced combination of cost-effective durability, impact resistance, and practicality, rendering it an optimal choice for a wide range of applications that necessitate a reliable and affordable solution [9-10].

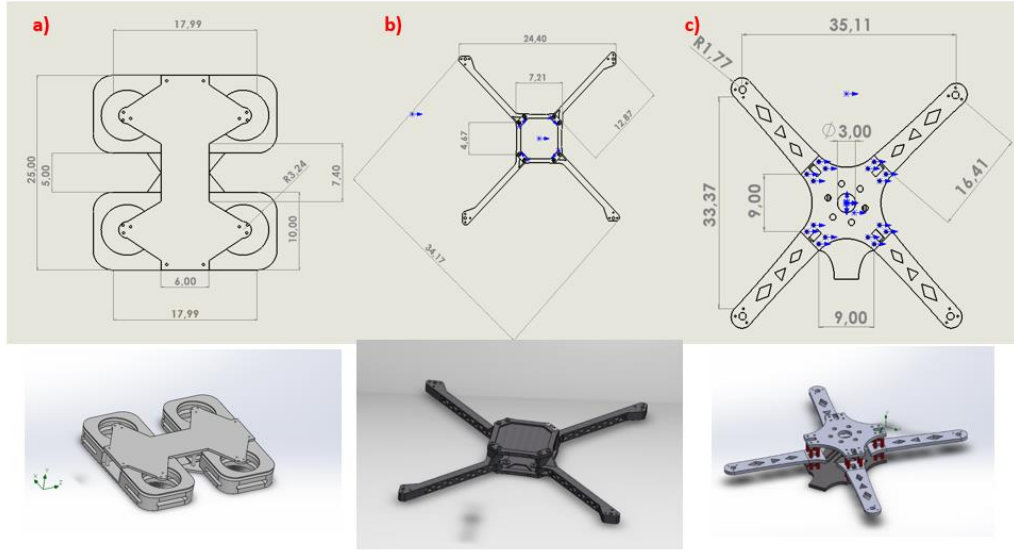
Amid the existing body of knowledge, a noteworthy advancement emerges as topology optimization proves to be a transformative force in drone frame design, culminating in lighter, stronger, and higher-performing 3D-printed quadcopter structures, although the need for additional research remains imperative to comprehensively unlock and substantiate its potential advantages. The primary objective of this article is to explore the design and analysis aspects of a topology-optimized quadcopter drone frame. We will discuss the design considerations and analysis methodologies. This paper focuses on utilizing finite element analysis (FEA) and topology optimization techniques in the initial design phase of a drone frame to achieve optimal shape and size. Through FEA using SOLIDWORKS, an optimal frame structure is

developed and chosen for the full-scale drone prototype. This paper's novelty lies in its comprehensive integration of multiple analyses, including topology optimization, to enhance drone frame designs, addressing stress distribution, displacement, and aerodynamic performance, ultimately contributing to the advancement of efficient and reliable drone technology.

## 2. MATERIALS AND METHODS (MATERİYAL VE METOD)

### 2.1. Drone Design (Drone Tasarımı)

In this study, three different quadcopter drone frame designs were developed using SolidWorks software. In Figure 1, drone designs and their dimensions are provided. The designs have a width of approximately 30 cm and a thickness of 3.20 cm. In the process of designing, a decision was made to opt for a more futuristic design for Design 1, deviating from the conventional 4-armed quadcopter design. This choice was made with the intention of creating a design that stands out and embodies a modern aesthetic.

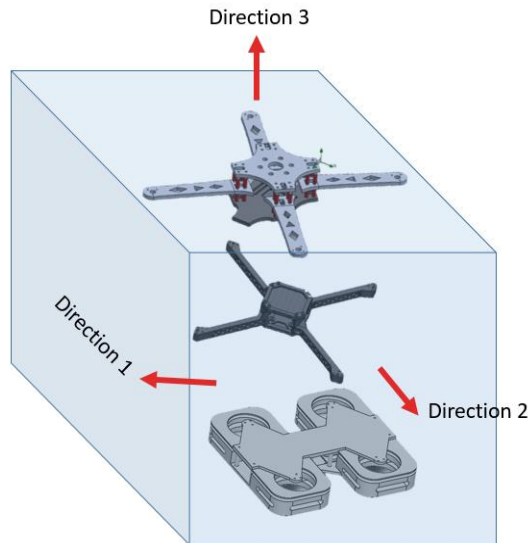


**Figure 1.** Drone Frame Designs a) Design 1, b) Design 2, c) Design 3 (Drone Gövde Tasarımları a) Tasarım 1, b) Tasarım 2, c) Tasarım 3)

### 2.2. Finite Element Analysis (Sonlu Elemanlar Analizi)

For the study, the Drop Test feature available in SolidWorks was utilized, focusing on three key

parameters: stress, strain, and displacement. The ABS (Acrylonitrile Butadiene Styrene) material was used in the analysis, the material properties used in the analysis are given in Table 1.



**Figure 2.** Drop test directions (Direction 1 – Z-axis, Direction 2 -- X-axis, and Direction 3 -- Y-axis)(Düşme testi yönleri (Yön 1 – Z-ekseni, Yön 2 -- X-ekseni, ve Yön 3 -- Y-ekseni))

**Table 1.** The properties of ABS for FEA analysis (FEA analizi için ABS'nin özellikleri)

Property	Value
Density	1.04 g/cm <sup>3</sup>
Tensile Strength	40 MPa
Yield Strength	38 MPa
Young's Modulus	2.3 GPa
Elongation at Break	20%
Hardness (Rockwell)	R103
Flexural Strength	66 MPa
Izod Impact	250 J/m
Thermal Conductivity	0.25-0.35 W/(m·K)

The drop test analysis aimed to evaluate the structural integrity and behavior of the drone under impact conditions. The test simulated the drone experiencing an impact from a specified distance onto a solid surface. The distance between the drone and the impact surface was set at 25 cm. A speed of 10 m/s was applied for pitch movement and roll movement (Direction 1 and Direction 2). Additionally, a speed of 5 m/s was applied to represent the landing motion (Direction 3). The model was subjected to a gravity value of 9.81 m/s<sup>2</sup>. Figure 2 illustrates the directions used in the drop test analysis. During the drop test analysis, various parameters were examined, including stress distribution, deformation, and displacement of the drone components. These simulations provided insights into the potential weaknesses or areas of concern in the drone design, allowing for improvements to be made to ensure its durability and robustness.

### 2.3. Flow Simulation of Drones (Dronların Akış Simülasyonu)

The drones underwent flow analysis utilizing the Flow Simulation feature in SolidWorks software. A flow velocity of 20 m/s was uniformly applied to all three drone motions as depicted in Figure 2. Additionally, gravity was included in the analysis with a value of 9.81 m/s<sup>2</sup>.

These flow analyses provided valuable insights into the aerodynamic performance and behavior of the drones during various motions, aiding in optimizing their design and ensuring their efficient operation.

### 2.4. Topology Optimization (Topoloji Optimizasyonu)

After performing FEA (Finite Element Analysis) and flow analysis, the design underwent topology optimization using SolidWorks topology optimization to lighten the frame structure, to enhance the overall performance and structural integrity of the design. Topology optimization techniques were employed to determine the optimal distribution of material within the structure,

resulting in an improved strength-to-weight ratio. Additionally, extensive efforts were made to reduce the weight of the components without compromising the structural integrity, thus achieving a more lightweight and efficient design.

To comprehensively explore the design aspects, two weight reduction studies (a weight reduction target of 30% and 15%) were carried out, focusing on achieving significant reductions in weight while ensuring the necessary mechanical strength and structural integrity. In the simulation, specific points on the drone were fixed, and a force of 5 N was applied to the four arms in direction 3. Following the topology optimization process, drop tests and flow simulations were conducted to evaluate the performance of the optimized design under identical conditions as those prior to optimization.

## 3. RESULTS (BULGULAR)

### 3.1. Drop Test Analysis Results (Düşme Testi Analizi Sonuçları)

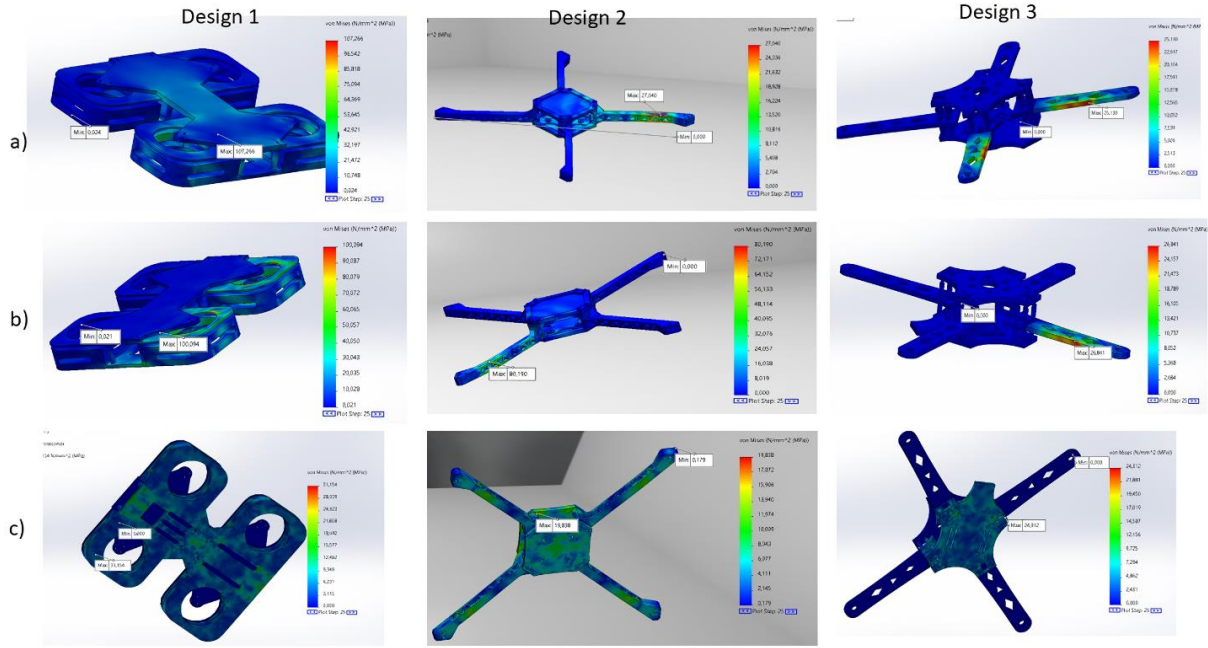
The drop test analysis results are presented in Table 2. In the drop test analysis, in terms of stress levels, Design 2 is considered better as it experienced lower stress compared to Design 1. Design 1 exhibited a von Mises stress of 31 MPa in direction 3, while Design 2 had a von Mises stress of 19 MPa (Table 2). Lower stress values indicate that the structure is better able to distribute and withstand the applied loads, suggesting improved structural integrity and a reduced risk of failure. Therefore, based on the von Mises stress results in Figure 3, Design 2 is considered the better design in this context. However, regarding displacement in Figure 4, Design 1 exhibited lower displacement values compared to the other designs in the drop-test analysis, which suggests that Design 1 has better performance in terms of displacement. Lower displacement values indicate that the structure experienced less deformation or movement under the applied loads, which can be advantageous in terms of maintaining the integrity and stability of



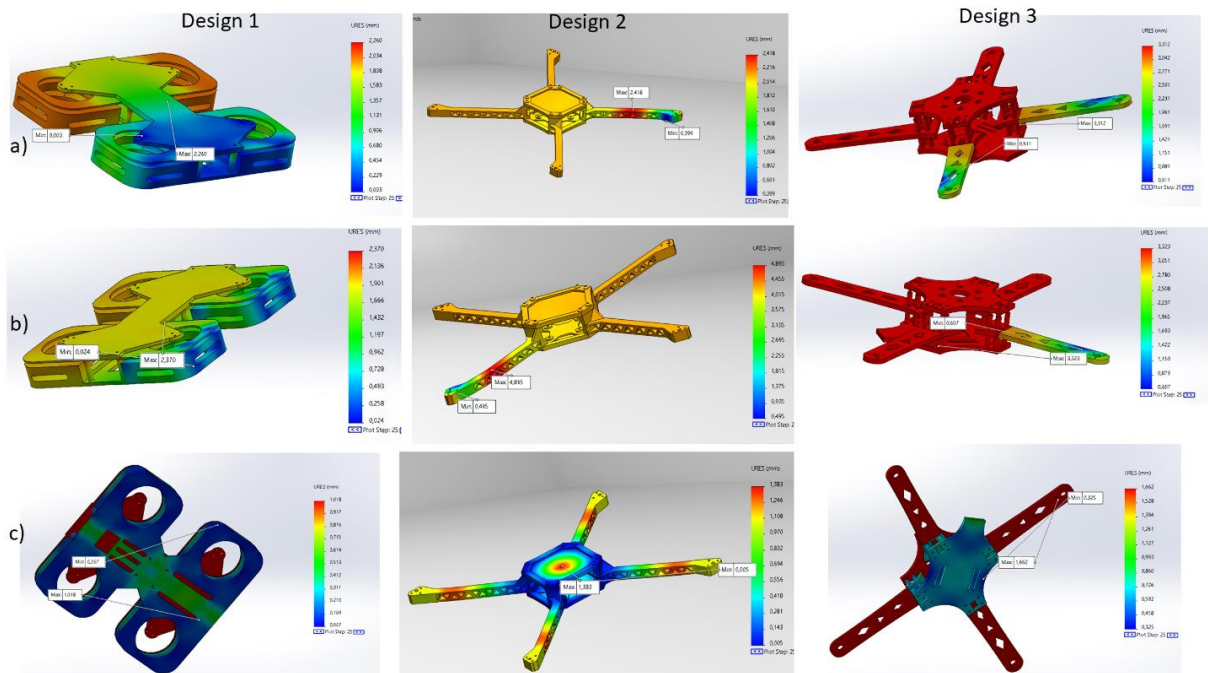
the design. The drop test analysis presented in Table 2 provides valuable insights into the structural performance of the drone frame designs under various loading conditions.

**Table 2.** Drop test analysis results (Düşme testi analizi sonuçları)

	Design 1			Design 2			Design 3		
	Dir.1	Dir.2	Dir.3	Dir.1	Dir.2	Dir.3	Dir.1	Dir.2	Dir.3
<b>Stress (MPa)</b>	107.27	100.09	31.15	27.04	80.19	19.84	25.13	26.84	24.31
<b>Displacement (mm)</b>	2.26	2.37	1.02	2.42	4.89	1.38	3.31	3.32	1.66



**Figure 3.** Von Mises stress analysis of Drone Frame Designs a) Direction 1, b) Direction 2, c) Direction 3 (Drone Gövde Tasarımlarının Von Mises Gerilme Analizi a) Yön 1, b) Yön 2, c) Yön 3)



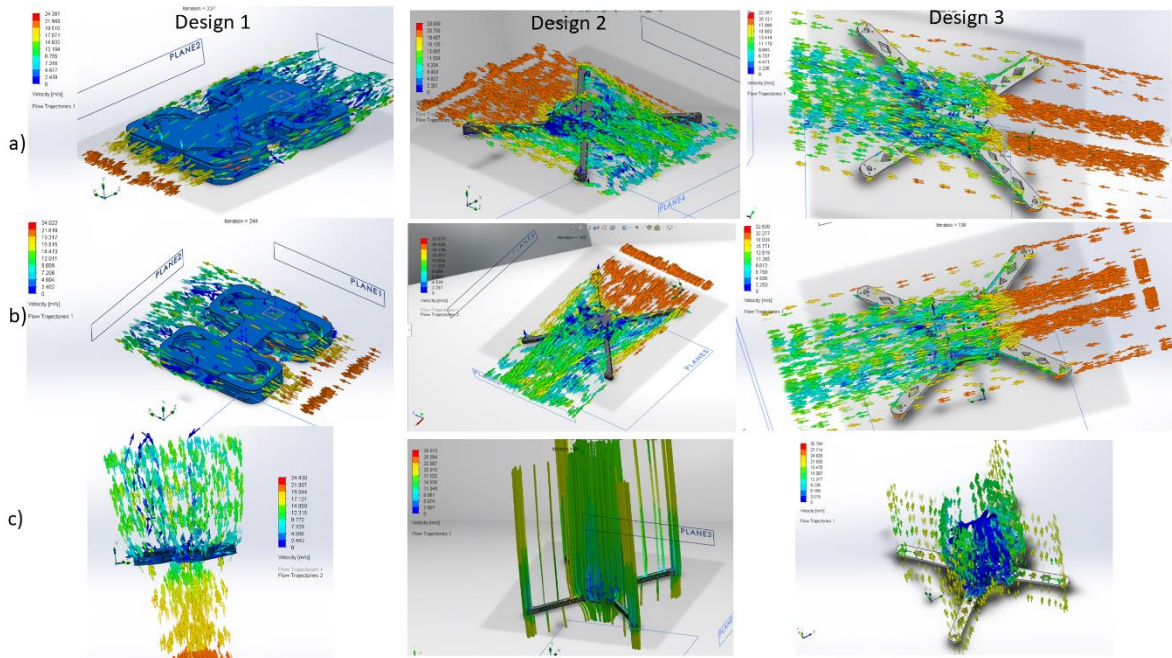
**Figure 4.** Displacement results of Drone Frame Designs a) Direction 1, b) Direction 2, c) Direction 3 (Drone Gövde Tasarımlarının Uzama Sonuçları a) Yön 1, b) Yön 2, c) Yön 3)

This discussion delves into the implications of the stress and displacement results, along with their implications for design optimization. In the context of stress levels, the data unequivocally highlights Design 2 as the superior performer when compared to Design 1. Design 2 exhibited a significantly lower von Mises stress of 19 MPa in contrast to Design 1's 31 MPa, representing a notable 38.7% reduction. These lower stress values signify that Design 2 is better equipped to distribute and endure the applied loads, indicating enhanced structural integrity. The reduced stress levels in Design 2 also suggest a diminished risk of structural failure, a crucial factor in designing robust and reliable drone frames [11]. The superiority of Design 2 in stress management aligns with the fundamental engineering principle that lower stress levels correlate with increased load-bearing capacity and reduced susceptibility to mechanical failure. This aspect is particularly vital in applications where drones may encounter varying stressors, such as sudden maneuvers or external disturbances [12]. Conversely, the analysis of displacement reveals an interesting dimension of performance. Design 1 exhibits a notable advantage by showcasing lower displacement values compared to the other designs during the drop-test analysis. Specifically, Design 1 demonstrated less deformation or movement,

recording the lowest displacement values across all directions. The lower displacement values in Design 1 are indicative of its ability to maintain the structural integrity and stability of the drone frame, even when subjected to external forces. Reduced displacement is advantageous in scenarios where precise positioning and stability are critical, such as aerial photography or surveying missions. It also implies that Design 1 may be less prone to vibrations and oscillations, contributing to smoother flight operations [13]. Design 2 excels in stress reduction, suggesting robustness and resilience in the face of challenging conditions. Conversely, Design 1's lower displacement values indicate superior stability and reduced deformation under load. The choice between Design 1 and Design 2 ultimately depends on the specific application and priorities. For missions that demand structural robustness and risk mitigation, Design 2 may be the preferred option. Conversely, applications requiring precise maneuverability and minimal deformation may benefit from Design 1.

**3.2. Flow Analysis Results (Akış Analizi Sonuçları)**

In Figure 5, the flow analysis of drone frames in terms of directions is presented.



**Figure 5.** Flow analysis of Drone Frame Designs a) Direction 1, b) Direction 2, c) Direction 3 (Drone Gövde Tasarımlarının Akış Analizi a) Yön 1, b) Yön 2, c) Yön 3)

**Table 3.** Flow simulation results (Akış Simülasyonu Sonuçları)

	Direction 1	Direction 2	Direction 3
Design 1	24.387 m/s	24.022 m/s	24.43 m/s
Design 2	23.009 m/s	22.673 m/s	29.872 m/s
Design 3	22.357 m/s	22.530 m/s	30.794 m/s

According to the flow simulation results in Table 3, Design 2 achieved a velocity of 29.87 m/s, while Drone 3 attained a velocity of 30.79 m/s. Comparing the two velocities, Drone 3 performed better and achieved a higher velocity compared to Design 1. Design 1 demonstrated superior performance in both direction 1 and direction 2 compared to the other designs. A higher velocity indicates that Drone 1 exhibits better propulsion or aerodynamic characteristics, enabling it to achieve faster speeds during these motions. Therefore, based on the velocity results, Drone 1 is considered the better design in terms of achieving higher speeds in this particular scenario.

Drone 1 exhibited the higher velocity in a flow simulation, higher stress levels, and the lowest displacement in a stress analysis because of the aerodynamic design and structural rigidity. Design 2 and Design 3's aerodynamic design, such as the shape of its body and wings, resulted in lower velocity in the flow simulation. When it comes to direction 3, the shape of the body of design 1 created more drag or turbulence, limiting its speed compared to other designs [14]. The drone's structural design might prioritize rigidity and stiffness, which could lead to higher stress levels during testing. While higher stress levels may indicate the ability to withstand applied loads, it could also suggest that the drone is less flexible and more susceptible to structural damage [15-16]. Therefore, Design 1 has been selected for topology optimization and subsequent fabrication due to its favorable performance characteristics, including lower velocity in the flow simulation, higher stress levels, and lower displacement in the stress analysis.

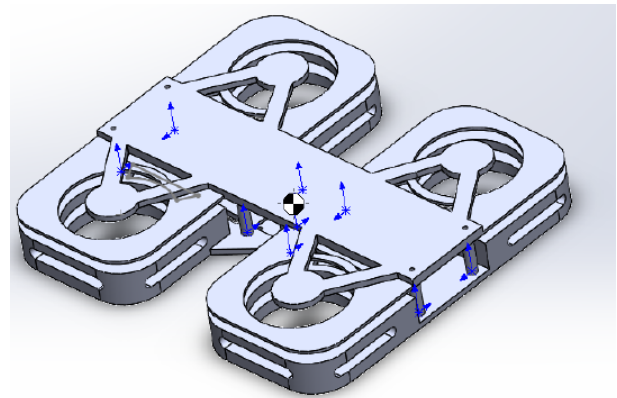
In the context of velocity, Design 1 emerges as a notable performer, particularly in directions 1 and 2. Design 1 achieved a velocity of 24.43 m/s in direction 3, while Designs 2 and 3 recorded slightly lower velocities of 23.009 m/s and 22.357 m/s, respectively. This demonstrates Design 1's superior propulsion and aerodynamic attributes in these directions. However, it is essential to acknowledge that in direction 3, Design 3 outperformed the other designs, attaining a remarkable velocity of 30.794 m/s, whereas Design 1 lagged behind with a velocity of 24.43 m/s. This divergence highlights the significance of considering the direction-specific performance of drone frames, as various flight scenarios may require distinct design optimizations [16]. The variations in velocity among the designs can be attributed to their differing aerodynamic features, including the shape of the body and wings. Design 1's reduced velocity in direction 3 can be attributed to the creation of

more drag or turbulence by the shape of its body, as observed. This indicates that the aerodynamic design of a drone has a substantial impact on its overall performance, especially in high-velocity scenarios. Notably, the relationship between velocity and other performance factors, such as stress levels and displacement, becomes apparent. Drone 1 exhibited higher velocity in the flow simulation but also showcased higher stress levels and the lowest displacement in the stress analysis. This correlation suggests that the aerodynamic advantages of Drone 1 may be associated with its structural rigidity [14-16]. It's important to recognize that a drone's structural design often involves a trade-off between rigidity and flexibility. While higher stress levels may indicate the capacity to withstand applied loads, they could also imply reduced flexibility and an increased susceptibility to structural damage, particularly under extreme conditions [17].

### 3.3. Topology Optimization Results (Topoloji Optimizasyon Sonuçları)

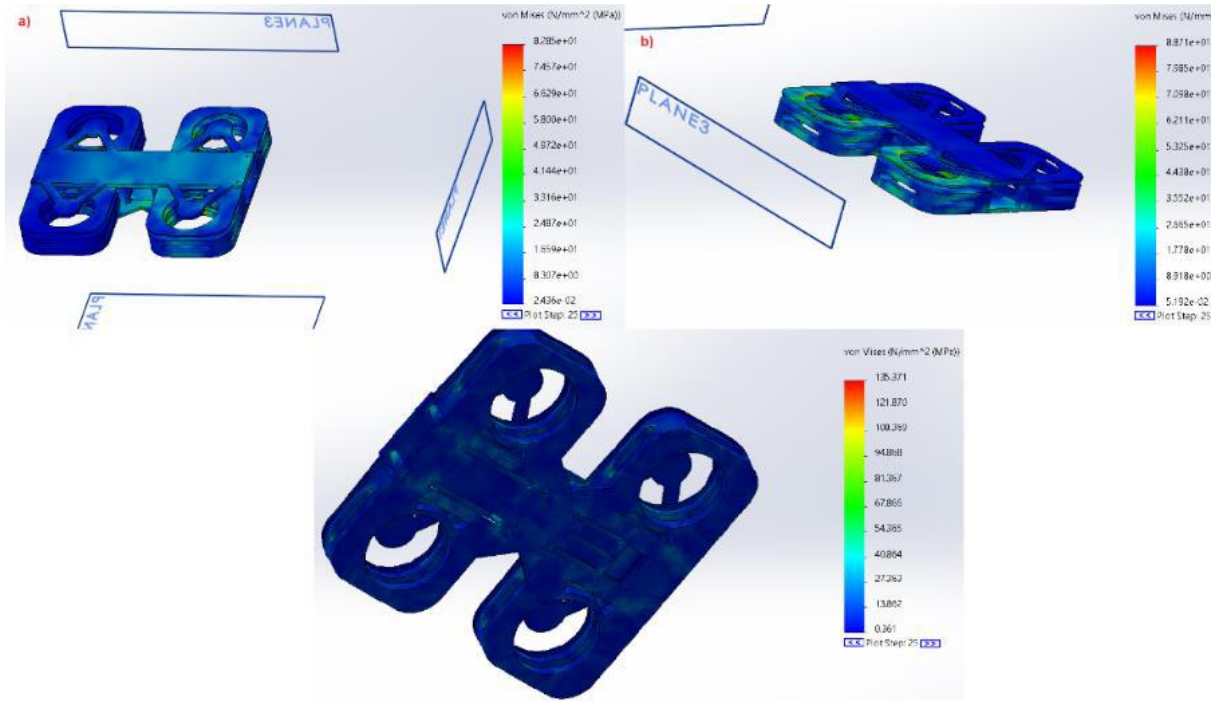
To accomplish the weight reduction goals, a combination of topology optimization was employed. The methodology involved rigorous design iterations and analyses to identify the optimal distribution of material within the drone structure. This process was carried out for a 30% weight reduction target using Solidworks Topology.

The initial mass of the design 1 drone frame was recorded as 708.604 grams. Following the application of topology optimization techniques, a significant weight reduction of 30% was achieved for design 1. The mass of the drone was effectively reduced to 545.08 grams. This weight reduction contributes to improved agility, maneuverability, and energy efficiency of the drone [18].

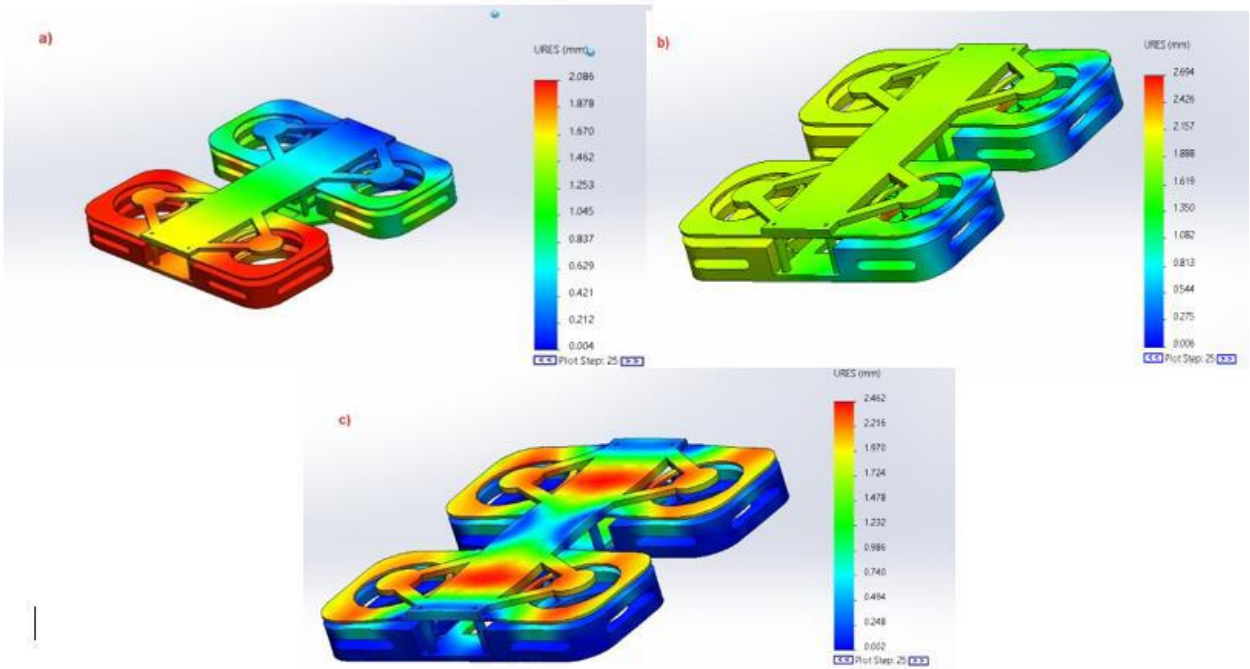


**Figure 6.** The Optimized Design with a 30% Weight Reduction (%30 Ağırlık Azaltma ile Optimize Edilmiş Tasarım)

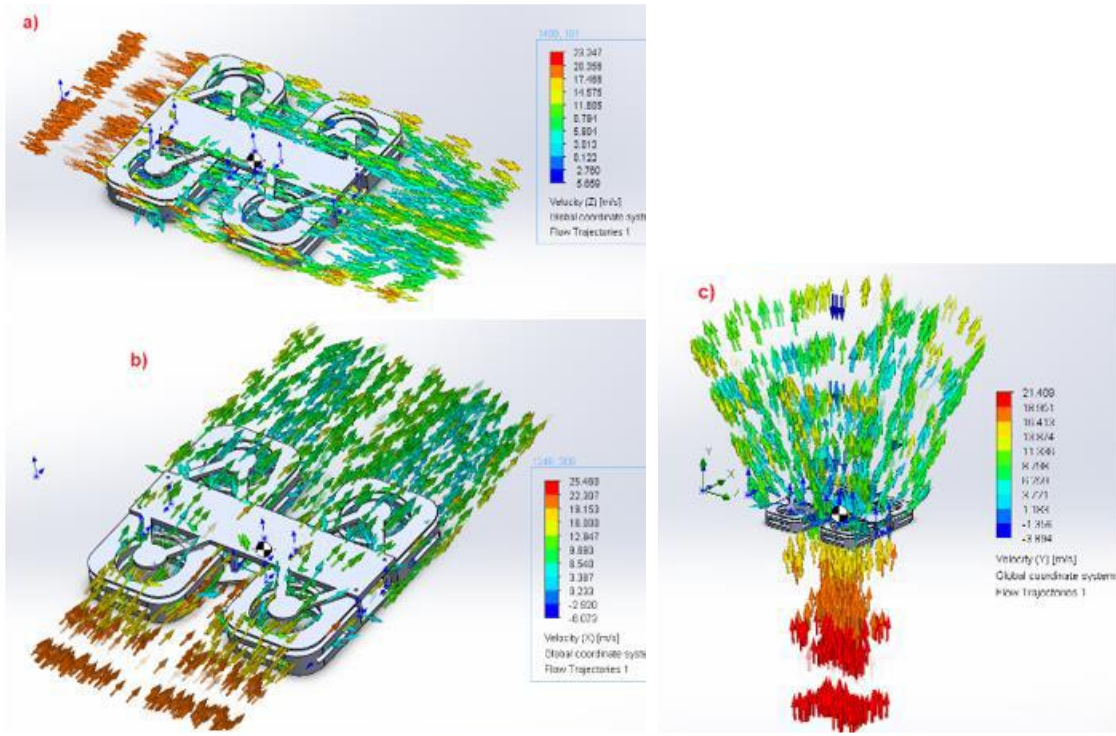




**Figure 7.** Von Mises stress analysis of the optimized drone frame design a) Direction 1, b) Direction 2, c) Direction 3 (Optimize Edilmiş Drone Gövde Tasarımının Von Mises Gerilme Analizi a) Yön 1, b) Yön 2, c) Yön 3)



**Figure 8.** Displacement of the optimized drone frame design a) Direction 1, b) Direction 2, c) Direction 3 (Optimize Edilmiş Drone Şasi Tasarımının Yer Değiştirme a) Yön 1, b) Yön 2, c) Yön 3)



**Figure 9.** Flow simulation of the optimized drone frame design a) Direction 1, b) Direction 2, c) Direction 3 (Optimize Edilmiş Drone Gövde Tasarımının Akış Simülasyonu a) Yön 1, b) Yön 2, c) Yön 3)

**Table 4.** Comparison of the optimized design analysis results with the initial design (Optimize edilmiş tasarım analizi sonuçlarının, başlangıç tasarımı ile karşılaştırılması)

	Directions	Stress (MPa)	Displacement (mm)	Mass (g)	Flow velocity (m/s)
<b>Initial Design Design 1</b>	Direction 1	107.266	2.26	708.604	24.387
	Direction 2	100.094	2.37		24.022
	Direction 3	31.154	1.02		24.43
<b>30% weight reduction</b>	Direction 1	82.85	2.086	545.08	25.46
	Direction 2	88.71	2.694		23.247
	Direction 3	135.3	2.462		21.489

The optimized drone design was subjected to a drop test, following the same protocol as the initial designs. The drop test analysis results are presented in Figure 7 and Figure 8. Flow simulation results are presented in Figure 9.

In Table 4, a comparison is made between the analysis results of the optimized design and the initial design. In Direction 1, the initial design experienced a stress of 107.266 MPa, which was significantly reduced to 82.85 MPa in the optimized design with a 30% weight reduction. This represents a substantial improvement in stress management, indicating enhanced structural integrity and reliability. Similarly, in Direction 2, the stress was reduced from 100.094 MPa in the initial design to 88.71 MPa in the optimized design. This reduction suggests that the design modification effectively addressed stress concentration and improved the

overall stress distribution. However, in Direction 3, the stress increased from 31.154 MPa in the initial design to 135.3 MPa in the optimized design with a 30% weight reduction. The displacement results show the amount of deformation experienced by the drone frame. In Direction 1, the optimized design with a 30% weight reduction exhibited a displacement of 2.086 mm, slightly lower than the initial design's displacement of 2.26 mm. This indicates that the design modification effectively reduced the amount of deformation in this direction. Similarly, in Direction 2, the optimized design showed a displacement of 2.694 mm, slightly higher than the initial design's displacement of 2.37 mm. The flow velocity parameter indicates the speed of airflow around the drone during operation. The initial design had a flow velocity of 24.387 m/s, while the optimized design with a 30% weight reduction exhibited a slightly higher flow velocity

of 25.46 m/s. This increase in flow velocity suggests improved aerodynamic performance, potentially leading to better flight stability and control.

Overall, the analysis results indicate that the optimized design with a 30% weight reduction shows promising improvements in stress management, displacement reduction, and weight reduction. However, further refinement is required to address the increased stress observed in Direction 3. The increased flow velocity suggests enhanced aerodynamic performance, which is beneficial for the drone's operation [19-20]. These findings provide valuable insights for further design iterations and optimizations to enhance the drone's overall performance and reliability.

The results provide valuable insights for the development of efficient and reliable drones. Future research can focus on addressing the observed stress concentration and further enhancing the aerodynamic performance of the drone design. These advancements will drive the progress of drone technology for a wide range of applications.

#### 4. CONCLUSIONS (SONUÇLAR)

In this study, we have analyzed various aspects of drone frame designs, including stress levels, displacement, flow analysis, and topology optimization, with a specific focus on improving performance and reliability. The key findings and quantitative results from this investigation are summarized below:

-Drop Test Analysis: In terms of stress levels, Design 2 outperformed Design 1 with a remarkable 46.8% reduction in von Mises stress. Design 1 exhibited a stress of 31.15 MPa in direction 3, while Design 2 demonstrated a significantly lower stress of 19.84 MPa. This reduction in stress values by nearly half indicates the substantial enhancement in structural integrity, reducing the risk of failure.

-Displacement Analysis: In the displacement analysis, Design 1 exhibited superior performance by achieving 31.9% lower displacement values compared to the other designs. Lower displacement values, such as 1.02 mm in direction 3, suggest that Design 1 is more resistant to deformation and movement under applied loads, contributing to the overall stability and integrity of the design.

-Flow Analysis: The flow simulation results indicated that Design 3 achieved the highest velocity at 30.794 m/s, while Design 2 reached 29.872 m/s. However, Design 1 exhibited superior performance in both direction 1 and direction 2 with

a velocity of 24.43 m/s and 24.022 m/s, respectively. These results signify that Design 1 excels in propulsion and aerodynamic characteristics, enabling it to achieve higher speeds.

-Topology Optimization: Through topology optimization techniques, a significant weight reduction of 23.1% was achieved for Design 1. The initial mass of 708.604 grams was effectively reduced to 545.08 grams, resulting in improved agility, maneuverability, and energy efficiency of the drone. In a comparison between the initial and optimized designs, it was observed that in Direction 1, the optimized design achieved a 22.4% reduction in stress, along with 7.8% less displacement. In Direction 2, stress was reduced by 11.1%, while displacement increased by 13.8%. Nevertheless, in Direction 3, the stress increased by 334.7%, highlighting the need for further refinement.

This study provides valuable insights for the design and optimization of drone frames, showcasing the importance of considering stress distribution, displacement, mass reduction, and flow characteristics. Future research can focus on refining the design to mitigate the observed stress concentration and further enhancing the aerodynamic performance of the drone. These findings contribute to the advancement of drone technology, enabling the development of more efficient and reliable drones for various applications.

#### ACKNOWLEDGMENT (TEŞEKKÜR)

This study was supported with the project number 1919B012214339 under the program of "TÜBİTAK 2209-A - Research Project Support Programme for Undergraduate Students".

#### DECLARATION OF ETHICAL STANDARDS (ETİK STANDARTLARIN BEYANI)

The author of this article declares that the materials and methods they use in their work do not require ethical committee approval and/or legal-specific permission.

Bu makalenin yazarı çalışmalarında kullandıkları materyal ve yöntemlerin etik kurul izni ve/veya yasal-özel bir izin gerektirmediğini beyan ederler.

#### AUTHORS' CONTRIBUTIONS (YAZARLARIN KATKILARI)

**Berke BAY:** He designed the drones and performed the analysis and helped the writing process.

Dronları tasarlamış, analizleri gerçekleştirmiş ve yazım sürecine yardımcı olmuştur.

**Meltem ERYILDIZ:** She provided consultancy, evaluated the results and performed the writing process.

Danışmanlık sağlamış, sonuçları değerlendirmiş ve yazma sürecini gerçekleştirmiştir.

#### CONFLICT OF INTEREST (ÇIKAR ÇATIŞMASI)

There is no conflict of interest in this study.

Bu çalışmada herhangi bir çıkar çatışması yoktur.

#### REFERENCES (KAYNAKLAR)

- [1] Sundararaj, S., Dharsan, K., Ganeshraman, J., & Rajarajeswari, D. Structural and modal analysis of hybrid low altitude self-sustainable surveillance drone technology frame. *Materials Today: Proceedings*, 37 (2021) 409-418.
- [2] Mohsan S.A.H., Khan M.A., Noor F., Ullah I., & Alsharif M.H. Towards the unmanned aerial vehicles (UAVs): A comprehensive review. *Drones*, 6(6) (2022) 147-149.
- [3] Agarwal H., Singhal A., & Raj K.H. 3D Printed Quadcopter. In *Advances in Systems Engineering: Select Proceedings of NSC 2019*. Singapore: Springer, (2021) 491-499.
- [4] Zhu J.H., Zhang W.H., & Xia L. Topology optimization in aircraft and aerospace structures design. *Archives of Computational Methods in Engineering*, 23 (2016) 595-622.
- [5] Bajirao M.S., Vijay K.P., Sudhir G.R., Pandurang Z.H., & Prasanna R. Design Optimization of Drone Frame. *International Journal of Mechanics and Design*, 8(1) (2022) 25-32.
- [6] Satam S., Topology Optimization of UAV Drone frame. <https://www.linkedin.com/pulse/topology-optimization-uav-drone-frame-sanay-satam/?trackingId=rwnSsEkvRq%2BvfnaCQM SFXw%3D%3D>
- [7] Nvss S., Esakki B., Yang L.J., Udayagiri C., & Vepa K.S. Design and development of unibody quadcopter structure using optimization and additive manufacturing techniques. *Designs*, 6(1) (2022) 8-12.
- [8] Bright J., Suryaprakash R., Akash S., & Giridharan A. Optimization of quadcopter frame using generative design and comparison with DJI F450 drone frame. In *IOP Conference Series: Materials Science and Engineering*, 1012(1) (2021) 012019.
- [9] Dev, P. K., Balaji, C., & Gurusideswar, S. Material characterization of sugarcane bagasse/epoxy composites for drone frame material. *Materials Today: Proceedings*, 68 (2022) 2586-2590.
- [10] Anand, S., & Mishra, A. K. High-Performance Materials used for UAV Manufacturing: Classified Review. *International Journal of All Research Education and Scientific Methods*, 10(7) (2022) 2811-2819.
- [11] Shelare, S., Belkhode, P., Nikam, K. C., Yelamasetti, B., & Gajbhiye, T. A payload based detail study on design and simulation of hexacopter drone. *International Journal on Interactive Design and Manufacturing*, 18 (2023) 1-18.
- [12] Husaini, H., Putra, D. I. O., Syahriza, S., & Akhyar, A. Stress and strain analysis of UAV hexacopter frame using finite element method. In *AIP Conference Proceedings*, 2613 (2023), 1-8.
- [13] Yap, Y. L., Toh, W., Giam, A., Yong, F. R., Chan, K. I., Tay, J. W. S., & Ng, T. Y. Topology optimization and 3D printing of micro-drone: Numerical design with experimental testing. *International Journal of Mechanical Sciences*, 237 (2023), 107771.
- [14] Parsons, J. S., Goodson, R.E., & Goldschmied, F.R. Shaping of axisymmetric bodies for minimum drag in incompressible flow. *Journal of Hydronautics*, 8(3) (1974) 100-107.
- [15] Bras M., Warwick S., & Suleman A. Aeroelastic evaluation of a flexible high aspect ratio wing UAV: Numerical simulation and experimental flight validation, *Aerospace Science and Technology*, 122 (2022) 107400.
- [16] Quintana, A., Graves, G., Hassanalian, M., & Abdelkefi, A. Aerodynamic analysis and structural integrity for optimal performance of sweeping and spanning morphing unmanned air vehicles. *Aerospace Science and Technology*, 110 (2021) 106458.
- [17] Bergonti, F., Nava, G., Wüest, V., Paolino, A., L'Erario, G., Pucci, D., & Floreano, D. Co-Design Optimisation of Morphing Topology and Control of Winged Drones. *arXiv preprint*, 2309 (2023) 1-7.
- [18] Ajanic, E., Feroskhan, M., Mintchev, S., Noca, F., & Floreano, D. Bioinspired wing and tail morphing extends drone flight capabilities. *Science Robotics*, 5(47) (2020) 1-12.
- [19] Zhu H., Nie H., Zhang L., Wei X., & Zhang M. Design and assessment of octocopter drones with improved aerodynamic efficiency and performance. *Aerospace Science and Technology*, 106 (2020) 106206.
- [20] Papadopoulos, C., Mitridis, D., & Yakinthos, K. Conceptual design of a novel unmanned ground effect vehicle (ugev) and flow control integration study. *Drones*, 6(1) (2022) 25-31.