

Research Article

Int J Energy Studies 2023; 8(3): 465-476

DOI: 10.58559/ijes.1344171

Received : 16 Aug 2023

Revised : 19 Aug 2023

Accepted : 21 Aug 2023

Effect of oxy-colorless distributed combustion of methane flame behaviour in a premixed gas turbine burner

Buğrahan Alabaş^{a*}, Zeliha Türkkahraman^b

^a Faculty of Aeronautics and Astronautics, Department of Aeronautical Engineering, Erciyes University, 38039, Kayseri, Turkey, ORCID: 0000-0002-1040-1110

^b Turkish Aerospace Industries Inc. 06560, Ankara, Turkey, ORCID: 0000-0001-9517-3219

(*Corresponding Author: bugrahanalabas@erciyes.edu.tr)

Highlights

- The oxy-colorless distributed combustion method was applied to the pure methane flame.
- It was observed that the flame temperature decreased as the O₂ ratio in the oxidizing air decreased.
- The oxy-colorless distributed combustion method provided zero NO_x emissions.
- As the CO₂ ratio in the oxidizer decreased, the flame length shortened.

You can cite this article as: Alabas B, Turkkahraman Z. Effect of oxy-colorless distributed combustion of methane flame behaviour in a premixed gas turbine burner. Int J Energy Studies 2023; 8(3): 465-476.

ABSTRACT

NO_x emissions and flame characteristics in gas turbine burners are a current issue. Different combustion methods are tested for the solution of NO_x emissions. One of these methods is oxy-colorless distributed combustion. In this method, CO₂ is used as a diluent instead of N₂ gas in the air. In this way, nitrogen does not enter the combustion chamber and theoretically NO_x emissions are planned to be zero. In this study, a premixed and swirl assisted gas turbine combustion chamber used experimentally was verified numerically. Analyzes were carried out by keeping 3 kW thermal power, 1 swirl ratio and 0.7 equivalence ratios constant. The oxy-colorless distributed combustion method was applied to the pure methane flame at different O₂/CO₂ ratios. Analyzes were carried out with the O₂ ratio of 26%, 21%, 19%, 17% and 15% by volume. The results showed that the colorless distributed combustion conditions were achieved as the CO₂ ratio increased. Thanks to the oxy-colorless distributed combustion method, almost zero NO_x emissions have been achieved. In addition, as the O₂ ratio in the oxidizer mixture decreased, a significant decrease in the flame temperature was detected. Thanks to this study, the effect of oxy-colorless distributed combustion conditions in a premixed and swirl supported combustion chamber was investigated.

Keywords: Methane, Oxy-colorless distributed combustion, Flame temperature

1. INTRODUCTION

In recent years, testing of alternative fuels has been frequently encountered in studies carried out for low-emission and efficient combustion. In addition to these, studies are carried out to reduce emission values and increase combustion efficiency by burning hydrocarbon fuels with alternative combustion methods. Different from traditional combustion methods, some of the combustion methods frequently encountered in the literature are; colorless dispersed combustion (CDC), oxy-colorless distributed combustion, Moderate or Intense Low-Oxygen Dilution Combustion (MILD) and oxy-fuel combustion. The main purpose of all of these methods is lower pollutant emission and higher combustion efficiency. Karyeyen et al. investigated the effect of hydrogen addition on oxy-colorless distributed combustion in a swirl-supported burner. In the study, 40%, 50% and 60% H₂ enrichment by volume was applied. The results showed that the transition to colorless distributed combustion started at 17%, 19% oxygen ratios. In addition, an increase in flame stability was observed at high oxygen ratios [1]. Khalil and Gupta investigated the role of CO₂ dilution in oxy-colorless distributed combustion. In the study, oxy-methane combustion was tested in a vortex-supported combustor. The O₂ content in the oxidizer was varied from 40% to 21%. The results revealed very low CO emissions and near-zero NO_x emissions [2].

Tu et al. tested oxy-MILD combustion conditions with the addition of H₂O in a pulverized coal. In the study, 70% CO₂ and 70% H₂O were used as diluents and two different situations were compared. The results show that lower CO emissions occur when H₂O is added. In addition, the addition of H₂O increases heat transfer and reduces NO_x emissions [3]. Perrone et al. performed a numerical analysis of pulverized coal under oxy-MILD combustion conditions in an industrial combustor. The results showed that the experimental system was numerically validated. Due to the absence of N₂ in the oxidizing air, NO_x formation is prevented [4]. İlbaş et al tested the biogas fuel in a swirl assisted burner experimentally and numerically under distributed combustion conditions. An O₂/CO₂ mixture containing 100% O₂ and 40% O₂ was used as the oxidizer. It has been determined that combustion starts faster and more efficiently when 100% O₂ is used. In addition, in this case, a higher temperature was detected in the fuel inlet region [5]. Khalil and Gupta investigated the effect of oxy-methane combustion on flame oscillations in a swirl-supported combustor. The results showed that the heat releases in oxy-methane combustion are below 60 Hz. In addition, it has been observed that if the O₂ ratio is reduced below 28% and the dilution is increased, colorless distributed combustion conditions are provided and a stable flame is formed [6].

Kekec et al. tested the colorless dispersed combustion of CH_4/H_2 fuel mixtures in a cyclonic burner. Three different fuel mixtures were tested, with a H_2 ratio of 40%, 50% and 60%. While the oxygen rate in the inlet air was reduced up to 13%, its temperature was increased up to 600 K. The results showed that CO_2 requirements significantly reduced NO_x emissions. In addition, CO_2 gas is more effective than N_2 gas in terms of NO_x reduction due to its thermal capacity [7]. Harun Yılmaz tested three different mixtures, primarily 50% CO / 50% H_2 , according to different combustion methods. In the study; oxy-fuel combustion, oxy-flameless distributed combustion and flameless distributed combustion methods were tested. The results showed that the reaction velocity increased due to the increased Reynolds number and turbulence effect as a result of the addition of O_2 [8]. Karyeyen and İlbaşı investigated the combustion of hydrogen-rich coal gases according to the distributed combustion technique. The results showed that in the case of distributed combustion, the maximum outlet temperature was reduced by 200 K and NO_x emissions were greatly reduced [9]. Fordoei et al. investigated the flame structure and emission behavior of methane air MILD combustion and oxy-methane combustion methods. The results showed that there was a significant gloss reduction as a result of the addition of CO_2 . While MILD combustion conditions significantly reduced NO_x emissions, CO emissions increased as a result of the addition of CO_2 [10].

When the literature is examined, there are many current studies on the dilution and combustion of different fuels. Gas turbine burners were used in a significant part of these studies [11,12]. When a detailed examination is made, there are some deficiencies in the studies in which pure methane flame is tested under oxy-colorless distributed combustion conditions, although studies are carried out especially on colorless distributed combustion. In this study, a premixed and swirl supported burner was used to fill the gap in the literature. A pure methane flame was validated by modeling an experimental thermo-acoustic combustion chamber [13]. After the reference combustion chamber was verified, oxy-colorless distributed combustion study of pure methane flame was carried out for the first time in this premixed and swirl supported combustion chamber. The combustion chamber, which is used as a reference, has been studied in 2D before, in this study it has been verified in 3D for the first time [8]. The reason why the study was carried out under oxy-colorless distributed combustion conditions is that N_2 gas does not enter the combustion chamber in this method. Instead of N_2 gas in the air, CO_2 is kept in the oxidizer. In this way, it is aimed to zero the NO_x emissions. Thanks to this study, the effect of oxy-colorless distributed combustion, which could not be carried out experimentally due to the high CO_2 demand in the thermo-acoustic

combustion chamber, on the flame behavior of pure methane flame and NO_x emission was investigated for the first time.

2. NUMERICAL MODEL

In this study, a thermo-acoustic combustion chamber used experimentally was modeled in 3D. In the experimental system, there are 2 loudspeakers in the combustion chamber arms and external acoustic pressure is applied. The loudspeaker part was not modeled in this study [14]. Flame exit temperature and emission data obtained in the study are presented as reference in the study of Alabaş et al. [13].

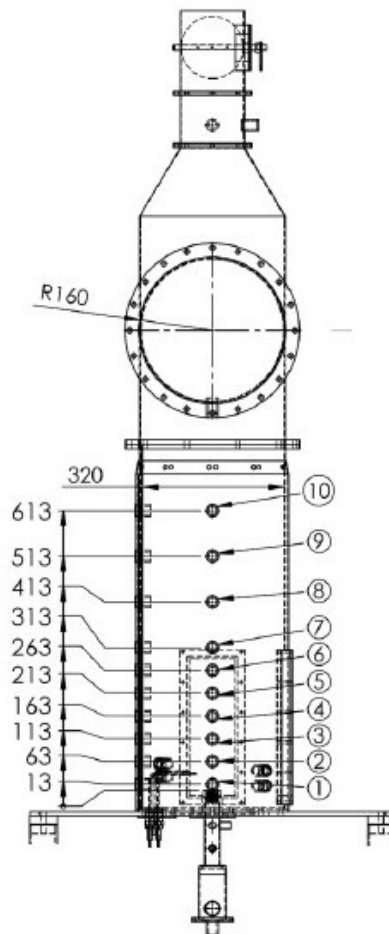

Figure 1. Model combustion chamber geometry

The experimental system was modeled and validated in 3D. The swirl number was kept constant as (1) and the equivalence ratio as 0.7 in all analyzes. Validation of the experimental data was carried out for the same values of methane/air combustion. The temperature of the inlet air and

fuel was kept constant at 300 K. In order to provide oxy-colorless distributed combustion conditions, firstly 21% O₂ was burned and the remaining diluent in the oxidizer was entered as 79% CO₂. Then, the O₂ ratio in the oxidizer was reduced to 19%, 17% and 15%. Temperature and velocity data were obtained under these conditions. Table 1 presents all the parameters of the numerical study. In addition, the mesh structure of the combustion chamber is presented in Figure 2, more frequent mesh is used to the swirl region while assigning the mesh structure.

Table 1. Numerical analysis parameters

Definition	Value/Parameter	Unit
Inlet Turbulent Intensity	5%	–
Heat Power	3	kW
Equivalence Ratio	0.7	–
Ambient Convective Heat Transfer Coefficient	40	W/m ² .K
Wall Thickness of the Combustor	0.001	m
Solver	Pressure-Based	–
Spatial Discretization	Second Order Upwind	–
Gradient	Least Squares Cell Based	–
Pressure	Standard	–
Pressure-Velocity Coupling	Simple	–
Mesh Number	500200	–

In this study, species transport equations were used. Continuity, energy and momentum equations are used in computational fluid dynamics studies. The heat transfer was considered when determining the boundary conditions. The entire transport equation is shown in equation 1 [11].

$$\frac{\partial(\rho\Phi)}{\partial t} + \text{div}(\rho\Phi k) = \text{div}(\Gamma\text{grad}\Phi) + S_{\Phi} \quad (1)$$

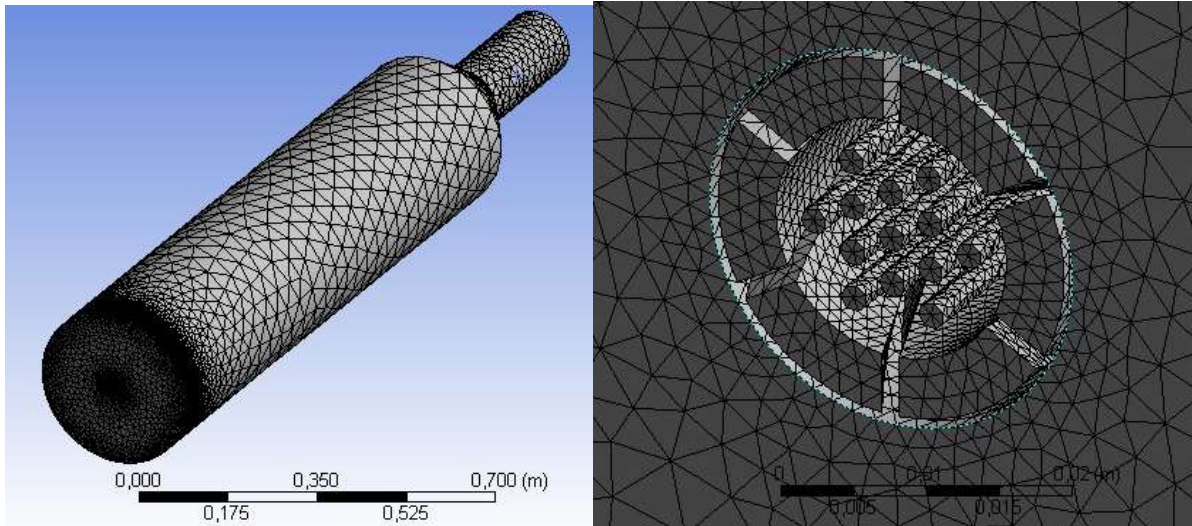

Figure 2. Combustion chamber mesh domain

3. RESULTS AND DISCUSSION

In this study, firstly, numerical verification of pure methane combustion was carried out. While verifying, Alabas et al., the data obtained in the experimental study was used. Figure 3 shows the temperature change in the combustion chamber. When the figure is examined, it is seen that methane/air combustion is confirmed with high consistency when the swirl generator is held at 1 and the equivalence ratio is 0.7. Especially after the burner exit, almost complete verification was carried out at a distance of 0.1 m. After the numerical verification of the experimental model, analyzes will be performed at different O₂/CO₂ ratios.

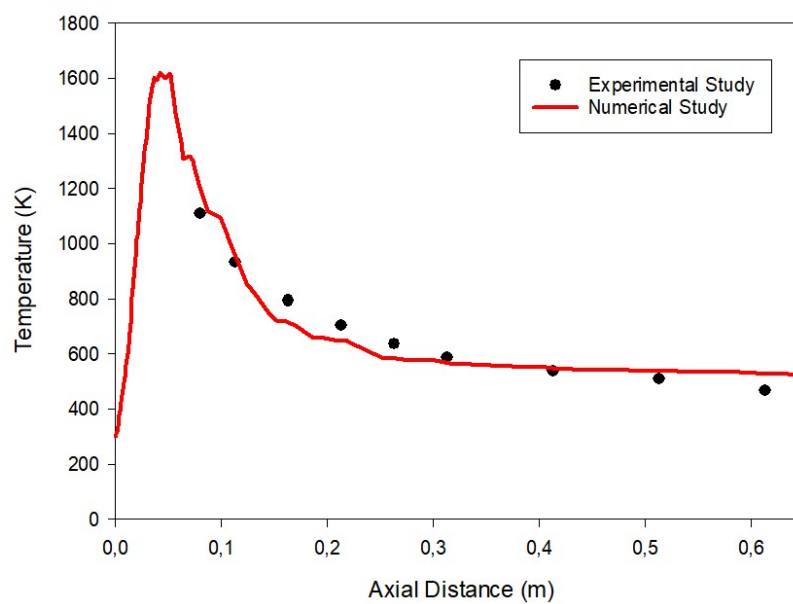

Figure 3. Verification of numerical method

The oxy-colorless distributed combustion analysis, which constitutes the original part of the study, was first started with an oxidizer mixture containing 26% O₂ - 74% CO₂. Although there is 21% O₂ by volume in standard air, there is Nitrogen gas as the diluent. In oxy combustion, there is carbon dioxide gas in the oxidizer instead of nitrogen. Since carbon dioxide gas has a higher density than nitrogen gas, firstly, combustion was carried out with a mixture containing low CO₂ [15]. When the temperature results are examined, it is seen that the maximum temperature value in the combustion chamber has increased up to 1645 K. In Figure 4, the flame image resulting from combustion with an oxidizer containing 26% O₂ is presented. A higher temperature occurred than in the standard O₂/N₂ containing air combustion with which the combustion chamber was verified. This situation was not considered suitable for the realization of colorless distributed combustion conditions. For this reason, it was thought that the analyzes should be continued by realizing a significant decrease in the O₂ ratio in the oxidizing mixture.

When the first results were examined, the oxidizing mixture containing 21% O₂ - 79% CO₂ was selected for the new analysis. The flame image and temperature changes resulting from the analysis with the new mixture are shown in Figure 4. In the current analysis, the CO₂ ratio in the combustion air has been increased and as a result, the maximum temperature of the combustion chamber has decreased to 1516 K. In order to fully see the colorless distributed combustion effect and to reduce the brightness of the flame, analyzes were carried out at lower O₂ ratios. When the O₂ ratio in the oxidizing air was reduced to 19%, the maximum temperature value in the combustion chamber was determined as 1450 K. When the oxygen ratio was reduced to 17%, as seen in Figure 3.d, the flame brightness gradually decreased and the maximum temperature of the combustion chamber decreased to 1410 K. Finally, the situation where the flame completely loses its brightness is seen in Figure 4.e. In this case, the flame temperature was measured at 1338 K, much lower than in all analyzes.

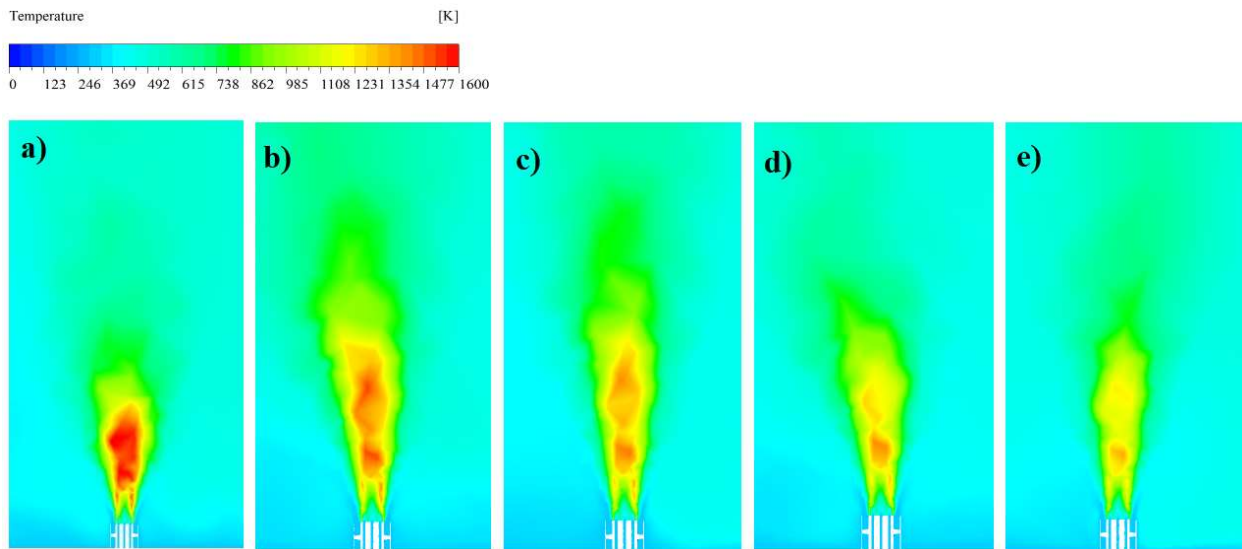

Figure 4. The image of pure methane flame in oxy-colorless distributed combustion conditions a) 26% O₂, b) 21% O₂, c) 19% O₂, d) 17% O₂, e) 15% O₂

When the obtained temperature and flame image shapes are examined, the flame temperature and brightness decrease as the O₂ ratio is reduced as a result of combustion with the oxidizing mixture containing O₂/CO₂. In this way, oxy-colorless distributed combustion conditions are realized. In addition, the combustion chamber flame temperature distributions under all O₂/CO₂ conditions are shown in Figure 5. When the figure is examined, it can be seen that the maximum temperature point decreases as the O₂ ratio decreases. When the literature is examined, it is an expected situation to experience a decrease in temperature as a result of decreasing the volumetric O₂ ratio in the oxidizing mixture and increasing the CO₂ ratio. CO₂ gas has a high thermal capacity and is an inert gas. It does not enter the combustion reaction and reduces the reaction rate. CO₂ gas is used in many studies in the literature to reduce the flame rate, especially in fuels with high hydrogen content [16]. Similarly, in this study, as the CO₂ ratio increased, the brightness of the flame decreased and a great decrease was observed in its temperature.

In addition, in the reference study, the NO_x emission of pure methane was measured as 8 ppm in the case of combustion with standard air containing 21% O₂ [13]. In this study, however, negligible data below 0.1 ppm were obtained, since nitrogen gas never entered the combustion chamber. The oxy-colorless distributed combustion requirements have served their purpose.

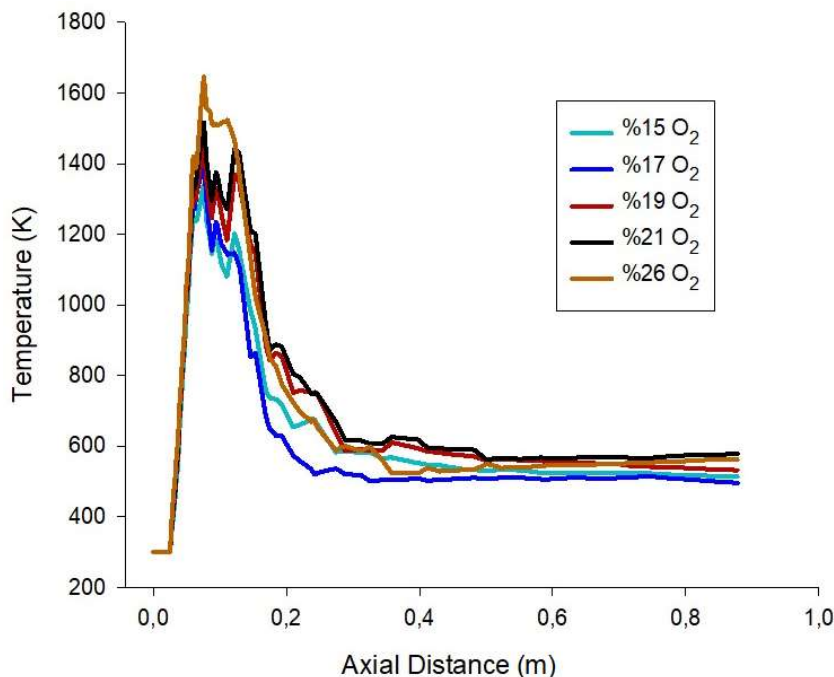

Figure 5. Combustion chamber temperature distribution at different O₂/CO₂ ratios

In the last stage of the study, the flow rates in the combustion chamber are presented. Figure 6 shows flow rates at all O₂/CO₂ ratios. As the amount of CO₂ entering the combustion chamber increases, the velocity increases as the density of the flow increases, so the highest flow rate occurred in the case of combustion with an oxidizer containing 15% O₂. On the contrary, in the case of high oxygen, it is seen in Figure 6.a that a rapid combustion occurs and the reaction does not continue for a long time. When Figure 4.a is re-examined with these images, it is observed that the flame size is the shortest.

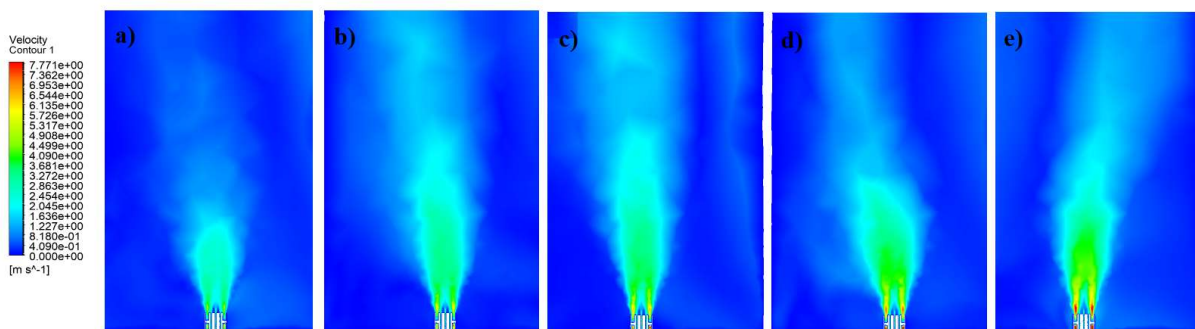

Figure 6. Velocity contours of a pure methane flame under oxy-colorless distributed combustion conditions a) 26% O₂, b) 21% O₂, c) 19% O₂, d) 17% O₂, e) 15% O₂

4. CONCLUSION

In this study, the flame behavior of pure methane flame under oxy-colorless distributed combustion conditions was numerically analyzed. After numerical verification of a thermo-acoustic combustion chamber, analyzes were carried out by changing the O₂/CO₂ ratios in the oxidizing air. The study revealed the following results;

- Colorless distributed combustion conditions reduced NO_x emissions to zero.
- With the decreasing O₂ ratio in the oxidizing mixture, a decrease of 307 K was detected in the flame temperature from 26% to 15%.
- When the O₂/CO₂ ratio in the oxidizer was 26/74%, a higher temperature occurred than in air combustion under standard conditions.
- As the O₂ ratio in the oxidizing mixture decreases, the flame brightness decreases and colorless distributed combustion conditions are obtained.
- In combustion with a high O₂ ratio, the fuel and oxidant mixture reacts quickly and is consumed. Therefore, the shortest flame length occurred under 26% O₂ conditions.

DECLARATION OF ETHICAL STANDARDS

The authors of the paper submitted declare that nothing which is necessary for achieving the paper requires ethical committee and/or legal-special permissions.

CONTRIBUTION OF THE AUTHORS

Buğrahan Alabaş: Made the validation and wrote the manuscript.

Zeliha Türkkahraman: Made numerical analysis.

CONFLICT OF INTEREST

There is no conflict of interest in this study.

REFERENCES

- [1] Karyeyen S, Feser JS, Gupta AK. Hydrogen concentration effects on swirl-stabilized oxy-colorless distributed combustion. *Fuel* 2019; 253: 772-780.
- [2] Khalil AEE, Gupta AK. The role of CO₂ on oxy-colorless distributed combustion. *Applied Energy* 2017; 188: 466-474.

- [3] Tu Y, Liu H, Su K, Chen S, Liu Z, Zheng C, Li W. Numerical study of H₂O addition effects on pulverized coal oxy-MILD combustion. *Fuel Processing Technology* 2015; 138: 252-262.
- [4] Perrone D, Castiglione T, Klimanek A, Morrone P, Amelio M. Numerical simulations on Oxy-MILD combustion of pulverized coal in an industrial boiler. *Fuel Processing Technology* 2018; 181: 361-374.
- [5] Ilbas M, Guler NU, Sahin M. Experimental and numerical investigation of biogas distributed combustion with different oxidizers in a swirl stabilized combustor. *Fuel* 2021; 304: 121452.
- [6] Khalil AEE, Gupta AK. Flame fluctuations in Oxy-CO₂-methane mixtures in swirl assisted distributed combustion. *Applied Energy* 2017; 204: 303-317.
- [7] Kekeç KB, Karyeyen S. H₂ – CH₄ blending fuels combustion using a cyclonic burner on colorless distributed combustion. *International Journal of Hydrogen Energy* 2022; 47(24): 12393-12409.
- [8] Yılmaz H. Assessment of Combustion and Emission Characteristics of Various Gas Mixtures under Different Combustion Techniques. *International Journal of Energy Studies* 2020; 5(1): 13-41.
- [9] Karyeyen S, Ilbas M. Application of distributed combustion technique to hydrogen-rich coal gases: A numerical investigation. *International Journal of Hydrogen Energy* 2019; 45(5): 3641-3650.
- [10] Fordoei EE, Mazaheri K, Mohammadpour A. Numerical study on the heat transfer characteristics, flame structure, and pollutants emission in the MILD methane-air, oxygen-enriched and oxy-methane combustion, *Energy* 2021; 218: 119524.
- [11] Ilbas M, Kumuk O, Karyeyen S. Modelling of the gas-turbine colorless distributed combustion: An application to hydrogen enriched – kerosene fuel. *International Journal of Hydrogen Energy* 2022; 47(24): 12354-12364.
- [12] Alabaş HA, Çeper BA. Effect of the hydrogen/kerosene blend on the combustion characteristics and pollutant emissions in a mini jet engine under CDC conditions. *International Journal of Hydrogen Energy* 2023 (In Press).
- [13] Alabaş B, Tunç G, Taştan M, Yılmaz İ. Experimental investigation of the emission behaviour and flame stability of the oxygen and hydrogen enriched methane under acoustic enforcement. *Fuel* 2021; 290: 120047.
- [14] Alabaş B, Altınay A. Equivalence Ratio Effect on Helium Diluted Methane Jet Flame Temperature and Pollutant Emission for a Swirl Assisted Gas Turbine Burner. *Journal of Aeronautics and Space Technologies* 2023; 16(1): 50-63.

[15] Tao C, Zhou H. Dilution effects of CO₂, Ar, N₂ and He microjets on the combustion dynamic and emission characteristics of unsteady premixed flame. *Aerospace Science and Technology* 2021; 111: 106537.

[16] Wei H, Xu Z, Zhou L, Zhao J, Yu J. Effect of hydrogen-air mixture diluted with argon/nitrogen/carbon dioxide on combustion processes in confined space. *International Journal Hydrogen Energy* 2018; 43(31): 14798-14805.