

Improved MEMS microphone frequency response through design-optimization

Neslihan DENGİZ^{1*} 

¹ Mechatronics Engineering Department, Sakarya University of Applied Sciences

ABSTRACT

Microphone main characteristic is to faithfully detect and transform incoming acoustic signal in electric one. Semiconductor based capacitive MEMS microphones, despite their limited dimensions, offer remarkable performances (frequency response, SNR). The purpose of this article is to introduce some design optimizations in the current SDM (Sealed-Dual-Membrane) capacitive MEMS microphone mainly concerning the position of the ventilation hole. The effects of the suggested modifications on the microphone's performances were evaluated using Lumped Model simulation tool. Device frequency response within audio-band clearly changed and a totally flat shape was obtained. Improvements in the microphone performances were also achieved, Signal-to-Noise Ratio (SNR) passed from a starting value of 71,24 dB to a final value of 71,49 dB. This SNR increase is related to the A-weighted noise decrease, it passed from 107,98 dB to 108,22 dB.

Keywords: capacitive MEMS microphone, frequency response, lumped model, ventilation hole, back-volume.

1 Introduction

Micro-Electro-Mechanical Systems, or MEMS, is a technology that can be broadly defined as miniaturized mechanical and electro-mechanical elements made using microfabrication techniques [1]. The critical physical dimensions of MEMS devices can range from well below a micron to several millimeters at the lower end of the dimensional spectrum. The most notable elements of MEMS devices are microsensors and micro-actuators [2]. Microsensors and micro-actuators are conveniently categorized as "transducers", defined as devices that convert energy from one form to another. In the case of microsensors, the device typically converts a measured mechanical signal into an electrical signal [2][3]. Many of these micromachine sensors have demonstrated performances that exceed those of their macro-scale counterparts. MEMS devices manufacturing methods are based on batch manufacturing techniques which can translate into low manufacturing costs per device [3]. As a result, it is possible to achieve excellent device performance but also to do so at a relatively low-cost level [4]. Unsurprisingly, silicon-based discrete microsensors are rapidly becoming commercially available and the markets for these devices continue to grow rapidly. The true potential of MEMS begins to emerge when these miniaturized

* Corresponding Author's email: g180918023@subu.edu.tr

sensors, actuators and structures can be combined on a common silicon substrate together with integrated circuits [2]. Microelectronic integrated circuits can be considered as the "brain" of a system, and MEMS augments this decision-making capability with "eyes" and "arms", enabling microsystems to sense and control the environment. Sensors collect information from the environment by measuring mechanical, thermal, biological, chemical, optical and magnetic phenomena. The electronics then process the information obtained from the sensors [3]. Furthermore, because MEMS devices are manufactured using mass production techniques, unprecedented levels of functionality, reliability and complexity can be placed on a small silicon chip at a relatively low cost [2, 4]. MEMS technology is extremely diverse and efficient, both in terms of expected application areas and how the devices are designed and manufactured. Capacitive microphones currently represent one of the most widespread application of MEMS devices. Their key performance parameters are primarily bound to their acoustic behavior and include frequency response, Signal-to-Noise Ratio (SNR), Total Harmonic Distortion (THD), Acoustical Overload Point (AOP) and package size. The starting point of our investigation is based on the SDM microphone design [5] that represents the most performing and sophisticated capacitive MEMS microphones. Many studies and simulations have been performed to improve and optimize its performances [6]. To improve its frequency response, especially near the lower limit of the audio-band (20 Hz – 20 kHz), a modification of the ventilation hole [7][8] position is suggested. This is beneficial for device performances because it makes the frequency response flat inside all the audio-band so the microphone is able to detect and transduce in the same way all the signals, independently from their frequency. Suggested modification of ventilation hole position is also beneficial for device stability and robustness over the time against contaminants like water and particles. Lumped model simulations have been performed to verify and support our expectations.

2 Material and method

2.1 Ventilation hole position

The ventilation hole is a circular opening required in the SDM membrane design to compensate for the slow pressure change between the back volume and the front volume (Bosch cavity). Microphones have to perform identically in different conditions at sea level and above sea level where the atmospheric pressure is different. In absence of the ventilation hole to compensate for this variation in atmospheric pressure, it is possible for a pressure difference to occur between the front volume, which is connected to the external environment through the sound port, and the back volume, which is completely enclosed. This difference may cause the membrane to pre-bend and change the membrane mechanical stress, consequently altering the acoustic performance of the microphone. The ventilation hole function is very important to guarantee the correct operating mode of the microphone, but it also has some disadvantages:

- it is a possible access for contaminants like water and particulate. These contaminants can enter the back-volume through the vent and permanently jeopardize MEMS membrane performances.
- It creates additional acoustic noise as the air volume has to flow from the larger front-volume (Bosch cavity) to a much smaller volume (ventilation hole channel).
- Combination of ventilation hole and back-volume is at the origin of the high-pass filter effect visible in the microphone frequency response. It has a corner frequency between 10 Hz and 40 Hz and gives the microphone frequency response its non-flat shape.
- It results in a reduction of the active area of the membrane capable of generating signals.

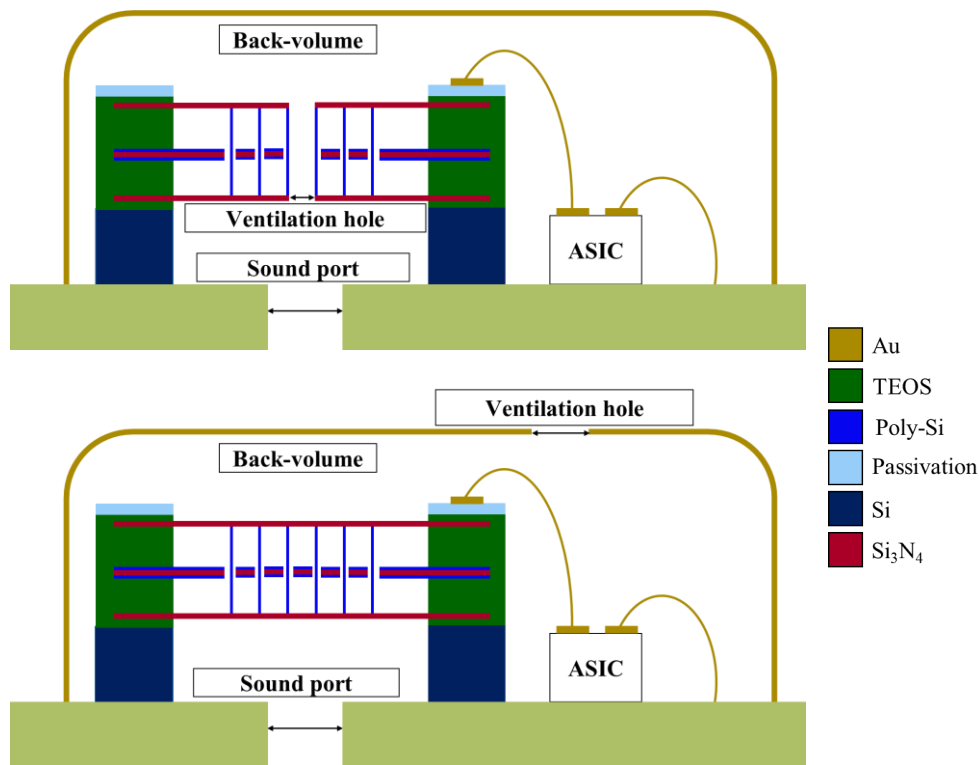

Fig. 1. On the upper side there is a cross section of current SDM MEMS microphone design where the ventilation hole is on the membrane and the lid is completely sealed. On the lower side there is a cross section of new SDM MEMS microphone design where the ventilation hole is on the lid while membrane has no opening.

In summary, the removal of the ventilation hole may provide some improvements in terms of acoustic performance (noise reduction, signal enhancement) and robustness, but the slow pressure compensation function must be implemented in an alternative way. A possible solution to compensate for atmospheric pressure variation is to add an opening in the microphone lid, so that a connection between the back-volume and the environment can be created (Figure 1). This design change is not only an alternative solution for the compensation of slow pressure variation, but also has some additional advantages:

- it reduces the microphone noise level because the ventilation hole channel, that generates noise, is removed and the back-volume is much larger and even infinite.
- Microphone robustness is improved.

In the current design, since the back-volume is confined and closed, the membrane oscillations are damped because a portion of their energy is used to compress this volume. Making the back volume larger or even infinite, the effects described above disappear. Regarding robustness, if the vent hole is removed from the membrane, contaminants (micro and nano particles, water) cannot access the back volume and add noise to the system by shrinking it, changing its acoustic behavior, or remain in the upper membrane, permanently changing its mechanical characteristics. Another important consequence resulting from the removal of the vent hole is related to the frequency response. Using the lumped model approach, the ventilation can be described as an acoustic resistor with resistance R , while the back volume can be described as an acoustic capacitor C . These two components form a series RC circuit [8]. Microphone output signal corresponds to the voltage on the resistance R (Figure 4), as consequence the above-mentioned circuits behaves like a high-pass filter with corner frequency f having the following expression

$$f = \frac{1}{2\pi RC} \tag{1}$$

where R is calculated using the Hagen-Poiseuille formula [9] for the acoustic resistance of a cylindrical channel and C is calculated using the back-volume dimensions and the air compressibility.

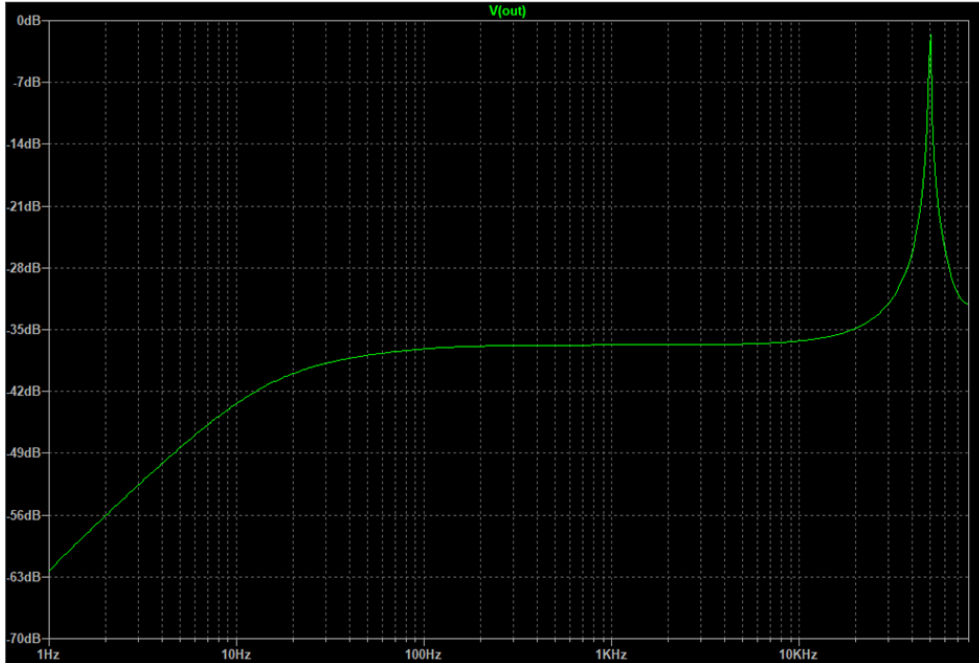

Fig. 2. Typical frequency response of SDM MEMS microphone with an approximately flat shape in the frequency range 40 Hz – 20 kHz and a corner frequency below 40 Hz.

2.2 Membrane clamping

In this section a new possible membrane design is proposed. It is finalized to increase the signal detected from the MEMS and to reduce the harmonic distortion when the acoustic signal has to be converted into an electrical signal. The current design consists of a highly compliant membrane clamped to its perimeter,

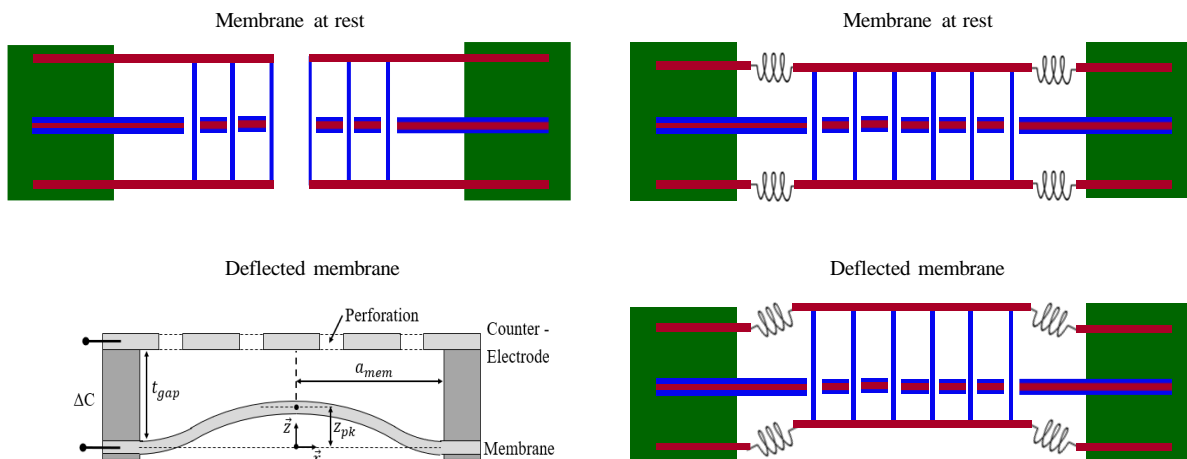

Fig. 3. On the left side the old membrane clamping design with the schematic showing the parabolic shape assumed by the membrane in presence of an acoustical signal. On the right side the new membrane clamping design and the schematic showing the flat shape assumed by the membrane in presence of an acoustical signal.

in the presence of an incoming signal, the membrane deflections assume a parabolic profile [10]. The central area of the membrane is the area of maximum displacement, therefore this part generates more signals than the other areas. In Figure 3 it is clearly showed that the current capacitive MEMS membrane behavior is only approximately described by a parallel plate capacitor, while its behavior is quite different [11]. To optimize the signal from the membrane and make its behavior more similar to that of a parallel plate capacitor, a new anchoring method of the membrane is proposed. The membrane material must be changed to a rigid material so that it does not deflect in the presence of an incoming sound wave. The membrane should be connected to the surrounding immovable structure using a spring design, so that it can be rigidly attached by means of these spring connections.

3 Results

The effect related to the modification of the vent hole was evaluated running a Lumped Model simulation using *LTspice* simulator software. An equivalent circuit [12] [13] can be used to simulate a complex acoustic and mechanical system such as a MEMS microphone. Such a circuit is constructed using appropriate correspondences between mechanical elements of the microphone and electrical components. The circuits describing the previous SDM MEMS microphone design and the new one are showed in Figure 4. The differences between them consist of the removal of the resistor R_{vent} parallel to the part of the circuit defining the membrane and the addition of a new resistor R_{lid} parallel to the components defining the back volume. The result of the simulation is relevant because it shows that the high-pass filter effect in the microphone frequency response disappears and becomes completely flat (Figure 5). A MEMS microphone with a completely flat frequency response over the entire audio band (20 Hz - 20 kHz) can

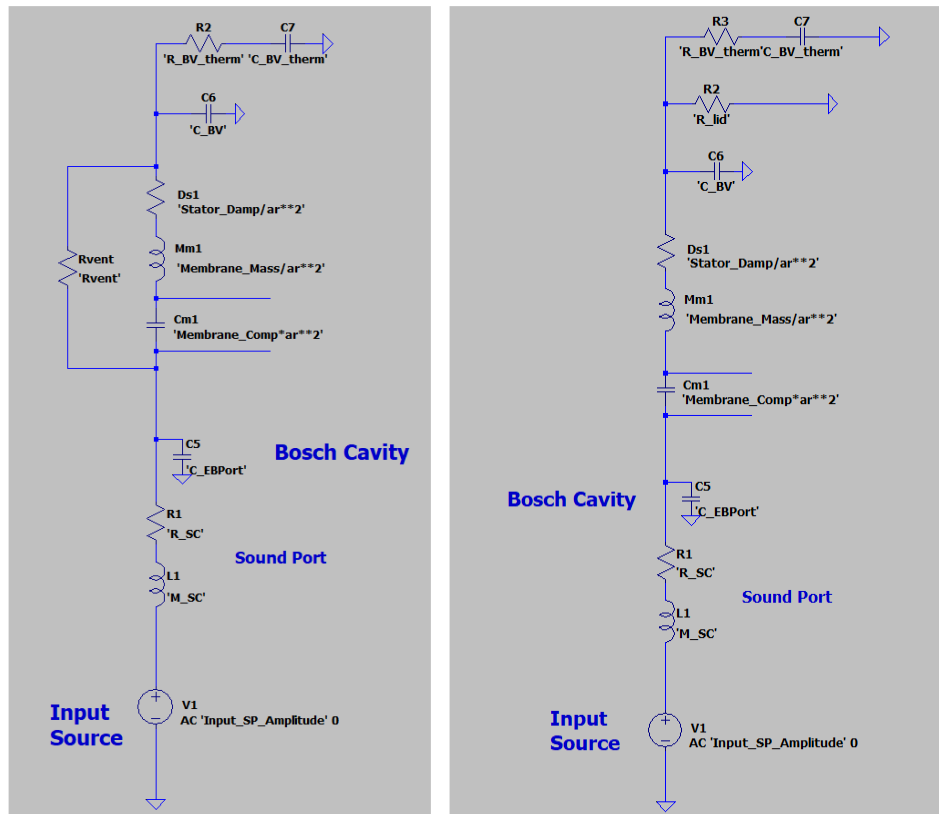

Fig. 4. On the left side the equivalent circuit describing the standard SDM MEMS microphone design, on the right side the equivalent circuit describing the modified design of the SDM MEMS microphone design.

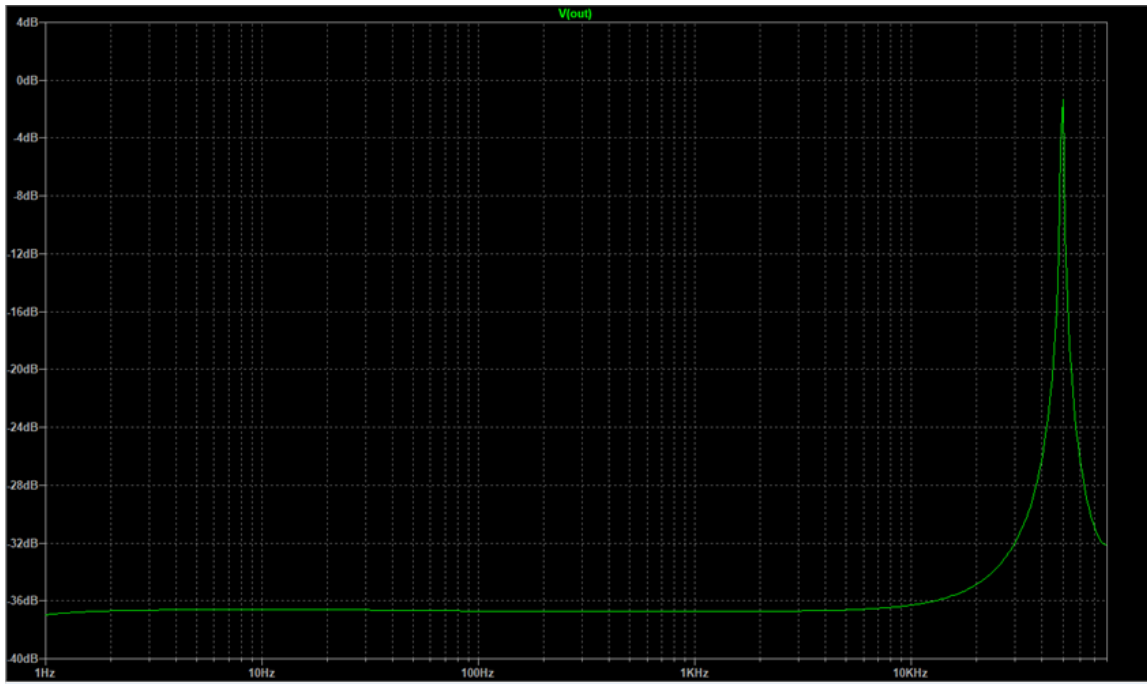

Fig. 5. Frequency response of SDM MEMS microphone with modified design. The high-pass filter effect disappeared so that sensitivity is approximately constant in all the audio band.

accurately detect sounds within this frequency range. In the field of applications, this new frequency response can provide a significant improvement, especially for devices that have limited dimensions but also need to reproduce sounds as accurately as possible. A relevant example is the hearing aid. The significant difference between the two frequency responses lies in the behavior at low frequencies (<40 Hz). The new design also improves the overall performance of the device, although not significantly, as can be seen by comparing the values of the three basic quantities (Sensitivity, A-weighted noise, SNR) that define the performance of a microphone (Table 1).

Table 1 Simulated values of Sensitivity, A-weighted noise and SNR related to the old design and new design.

Simulated quantities	Previous design	New design
Sensitivity (dBV)	-36,74	-36,74
A-noise (dBV)	-107,98	-108,22
SNR (dB)	71,24	71,49

4 Conclusion

Ventilation hole removal can bring some improvements in terms of acoustic performances (noise reduction, signal enhancement) and robustness but slow pressure variations due to the change in environmental conditions have to be compensate. The suggested solution implies the creation of an opening in the lid, creating a connection between the back-volume and the environment. As consequence

of this design modification, microphone frequency response becomes completely flat therefore every acoustic wave having a frequency inside the audio band, can be detected by the microphone with the same accuracy. Just mentioned capability of the new designed microphones and their improved robustness to contaminants makes them suitable to be integrated in medical devices like hearing aids. To further improve the microphone acoustic performances, especially noise reduction, using the suggested design, additional studies can be done regarding the dimension, the number and position of the holes implemented in the lid.

5 Declarations

5.1 Competing Interests

There is no conflict of interest in this study.

References

- [1] Stephen D. Senturia. *Microsystem design*. Springer New York, NY. <https://doi.org/10.1007/b117574>
- [2] Judy, Jack. (2001). *Microelectromechanical systems (MEMS): Fabrication, design and applications*. *Smart Materials and Structures*. 10. 1115-1134. 10.1088/0964-1726/10/6/301.
- [3] Gad-el-Hak, Mohamed & Seemann, We. (2002). *MEMS handbook*. *Applied Mechanics Reviews*. 55. 109-. 10.1115/1.1508147.
- [4] J H Rector *et al*, Optimization of the batch production of silicon fiber-top MEMS devices, 2017 *J. Micromech. Microeng.* **27** 115005.
- [5] Moore, J., Davis, C., Coplan, M., & Greer, S. (2009). *Building Scientific Apparatus* (4th ed.). Cambridge: Cambridge University Press. doi:10.1017/CBO9780511609794.
- [6] V. Naderyan *et al.*, "MEMS microphone with 73dBA SNR IN A 4mm x 3mm x 1.2mm Package," *2021 21st International Conference on Solid-State Sensors, Actuators and Microsystems (Transducers)*, Orlando, FL, USA, 2021, pp. 242-245, doi: 10.1109/Transducers50396.2021.9495414.
- [7] L. Sant *et al.*, "A 130dB SPL 72dB SNR MEMS Microphone Using a Sealed-Dual Membrane Transducer and a Power-Scaling Read-Out ASIC," in *IEEE Sensors Journal*, vol. 22, no. 8, pp. 7825-7833, 15 April 15, 2022, doi: 10.1109/JSEN.2022.3154446.
- [8] A. Dehé, M. Wurzer, M. Földner, and U. Krumbein, "The Infineon silicon MEMS microphone," in *Proc. AMA Conf. Sensors*, 2013, pp. 95–99.
- [9] Landau, Lifshitz, *Fluid Mechanics (Second Edition)*, Pergamon, 1987, ISBN 9780080339337, <https://doi.org/10.1016/B978-0-08-033933-7.50010-6>.
- [10] S. Anzinger, C. Bretthauer, D. Tumpold and A. Dehé, "A Non-Linear Lumped Model for the Electro-Mechanical Coupling in Capacitive MEMS Microphones," in *Journal of Microelectromechanical Systems*, vol. 30, no. 3, pp. 360-368, June 2021, doi: 10.1109/JMEMS.2021.3065129.
- [11] S. Anzinger, A. Fusco, D. Tumpold, C. Bretthauer and A. Dehé, "Modeling of Dual-Backplate based Airborne CMUTs with Enhanced Bandwidth," *2020 IEEE International Ultrasonics Symposium (IUS)*, Las Vegas, NV, USA, 2020, pp. 1-4, doi: 10.1109/IUS46767.2020.9251571.

- [12] Lenk, Arno & Ballas, Rüdiger & Werthschützky, Roland & Pfeifer, Günther. (2011). Electromechanical Systems in Microtechnology and Mechatronics – Electrical, Mechanical and Acoustic Networks, their Interactions and Applications. 10.1007/978-3-642-10806-8.
- [13] Shubham, Shubham & Seo, Yoonho & Naderyan, Vahid & Song, Xin & Frank, Anthony & Johnson, Jeremy & Silva, Mark & Pedersen, Michael. (2021). A Novel MEMS Capacitive Microphone with Semiconstrained Diaphragm Supported with Center and Peripheral Backplate Protrusions. Micromachines. 13. 22. 10.3390/mi13010022.



© 2020 by the authors. Submitted for possible open access publication under the terms and conditions of the Creative Commons Attribution (CC BY) license (<http://creativecommons.org/licenses/by/4.0/>).