



<http://www.tayjournal.com>

<https://dergipark.org.tr/en/pub/tayjournal>

## Development of an Environmental Attitude Scale for Primary School Students\*

**☐ Cahide Karakaş Tan, Teacher, Corresponding Author**  
Ministry of National Education, Türkiye  
karakastan.cahide@gmail.com  
Orcid ID: 0009-0006-9165-8255

**☐ Mutlu Pınar Demirci Güler, Prof. Dr.**  
Kırşehir Ahi Evran University, Türkiye  
pinarguler@ahievran.edu.tr  
Orcid ID: 0000-0002-8286-4472

**Article Type:** Research Article

**Received Date:** 30.10.2023

**Accepted Date:** 18.07.2024

**Published Date:** 31.07.2024

**Plagiarism:** This article has been reviewed by at least two referees and scanned via a plagiarism software

**Doi:** 10.29329/tayjournal.2024.653.05

**Citation:** Karakaş Tan, C., & Demirci Güler, M. P. (2024). Development of an environmental attitude scale for primary school students. *Türk Akademik Yayınlar Dergisi (TAY Journal)*, 8(2), 287-316.

\*This article was produced from Cahide Karakaş Tan's master's thesis supervised by Prof. Dr. Mutlu Pınar Demirci Güler.

## **Abstract**

This study aims to develop a valid and reliable measurement tool to determine the environmental attitude levels of primary school students. The research adopts a quantitative research design and is of a survey study nature. The study was conducted during the 2022-2023 academic year with the participation of 948 students from primary schools in Kırşehir. The likert-type scale development model was used in the study. Considering that the items in the measurement tool are related to each other, the promax oblique rotation technique was used in the explanatory factor analysis [EFA]. As a result of the rotation technique applied three times, a 17 item scale consisting of 3 sub-factors was obtained. The result of the Kaiser-Meyer-Olkin [KMO] Test of the scale was calculated as .837. The Bartlett Test result was found to be significant ( $p < .00$ ). As a result of the validity and reliability analyses of the developed data collection tool, it was observed that the Cronbach's alpha internal consistency coefficient calculated in the explanatory factor analysis increased from .76 to .91 in the confirmatory factor analysis. As a result of the study, a valid and reliable measurement tool was developed to determine the environmental attitude levels of primary school students. The developed scale can be revised in line with the curriculum and learning outcomes for different grade levels.

**Keywords:** Attitude, environment, primary school, scale development.

## **Introduction**

Human beings have interacted with their environment since their existence, affecting the environment they live in and being affected by it. In general terms, the environment refers to the living space of organisms. The living space is an area where people maintain their relationships in social, biological, economic, physical, and cultural aspects and interact mutually. It is also a place where people communicate, realize themselves, and integrate with their inner world, in other words, where they find themselves. In this context, it can be said that the environment is not only a physical space for humans but also plays an important role personally and psychologically. It is known that interactions with the environment are significant for an individual's self-realization (Ada et al., 2017; Çabuk & Karacaoğlu, 2003; Kavruk, 2002; Yalçinkaya, 2012).

The environment is important both individually and socially. Every positive or negative activity individuals perform on the environment not only impacts their immediate surroundings but also affects the broader societal environment. Therefore, it is undoubtedly crucial for individuals to be aware of their impact on the environment in their daily lives. This awareness can be achieved by providing individuals with environmental education. Environmental education can be defined as an interdisciplinary approach that continues throughout an individual's life, aiming to make individuals knowledgeable, solution-oriented towards problems, and responsible in their actions concerning environmental issues (Chepesiuk, 2007; Moseley, 2000). Within this framework, environmental education aims to foster positive attitudes towards the environment and encourage a critical perspective in interactions with it. Consequently, it aims to raise individuals who are sensitive and knowledgeable about leaving a clean and healthy environment for future generations. Additionally, environmental education can transform and enhance individuals' problem-solving skills, their ability to question information, and their capability to reach conclusions and make decisions (Doğan, 1997; Görümlü, 2003).

In all dimensions of environmental education, the importance of starting environmental-related activities at an early age is emphasized. Childhood is considered a critical period for developing sensitivity, gaining knowledge, feeling concern, and becoming aware of the natural world. Therefore, instilling environmental sensitivity and awareness in children during this period through family and school is crucial. The foundational gains of this awareness process, which begins with the family, can be provided during preschool and primary education. Environmental education that starts at an early age is vital for forming individuals' environmental attitudes and awareness (Demirkaya, 2006; Erten, 2004; Gök & Afyon, 2015; Gökçe et al., 2007). Atasoy (2006) stated that, beyond its obligatory nature, primary school is not a superficial and simple education period but actually forms the foundation of the entire education system. The primary school period is a critical educational stage with a complex structure that should be prioritized. Considering the high number of students in our country who are unable to continue to higher education levels, the importance of environmental education provided during the basic education process becomes evident (Gürkan & Gökçe, 1999).

Attitude can be defined as tendencies formed as a result of learning that push individuals to exhibit certain behaviors (Demirel, 1993). Considering that attitude is formed as a result of learning and that the critical period for learning is at the basic education level, it can be said that providing environmental education at an early age is effective in creating environmental sensitivity and developing positive attitudes towards the environment in individuals. The components of attitude consist of three dimensions: cognitive, emotional, and behavioral (Morgan, 1991). These components are considered to have internal consistency with each other. According to this assumption, if the knowledge an individual has about a subject leads them to approach it positively, it is called the "cognitive component." If the person has positive feelings about that subject, it is called the "emotional component." If they express these feelings and thoughts through words or actions, it is called the "behavioral component." Therefore, attitudes are not just a combination of knowledge, tendency, and emotion but are a whole formed by the blending of the cognition-emotion-behavior tendency (İnceoğlu, 1993). The cognitive dimension of attitude consists of factual information and beliefs related to attitude objects (stimuli). This information represents the knowledge that individuals acquire about attitude objects in the environment. The more factual this information is, the more permanent the individuals' attitudes will be. When individuals' knowledge about that attitude changes, their attitudes also change (Tavşancıl, 2010). The affective dimension of attitude includes an individual's emotional responses to the attitude object and their evaluations in this context. The affective component gives continuity to the attitude, shapes it, and influences it (Erdoğan, 1999). The behavioral dimension of attitude is the third component. Allport (1967) sees attitude as essentially a tendency to move in a certain direction and emphasizes the information it can express as a result of behavior. An attitude essentially predisposes an individual to behave in a certain way towards the attitude object. An individual who develops a positive attitude towards an object will tend to engage in positive behaviors related to that object, stay close to it, and help it. Conversely, an individual who develops a negative attitude towards an object will tend to ignore it or stay away from it, criticize it, and even engage in behaviors that harm it. Research indicates that while individuals' behaviors can be directly

observed, a scale is needed to measure their attitudes (Çınar et al., 2008; Meyerhoff, 2006). Based on this need, the aim of the study is to develop a valid and reliable scale to determine the environmental attitudes of primary school students. A review of the literature reveals scale development studies for environmental attitudes aimed at first-grade primary school students (Demir, 2016; Yaşaroğlu and Akdağ, 2013), second-grade primary school students (Demirkaya and Genç, 2006; Kılıç and Kan, 2020), and pre-service teachers' attitudes towards the environment (Afacan & Demirci Güler, 2011; Kahyaoglu, 2011; Okur & Yalçın Özdilek, 2012; Tuncer, 2021). However, there is no scale in the literature that comprehensively addresses the entire primary school curriculum, determines environmental gains, and is developed based on the three dimensions of attitude. Therefore, this study can be considered a significant contribution to the literature.

During the development process of the scale, two main points were considered while creating the item pool. The first point is addressing the cognitive, affective, and behavioral dimensions, which are the components of attitude, in the process of creating the scale items. The second point is examining the curricula of all subjects taught in the first, second, third, and fourth grades of primary school and forming the scale items based on the environmental gains identified in these curricula. The developed scale can serve as a tool for educators to determine the environmental attitude levels of primary school students. In this context, the study sought to answer the question, "How can a scale be developed to determine the environmental attitude levels of primary school students?"

## **Method**

### **Research Design**

The research aimed to develop a valid and reliable measurement tool to determine primary school students' attitudes towards the environment. The research adopts a singular survey model from general survey models. With the singular survey model, efforts were made to determine students' current situations. The singular survey model is used to gain a general understanding of the universe through a specific group or subset, rather than the entire population (Bailey, 1982).

### **Population and Sample**

The population of the study consisted of students attending primary schools in Kırşehir province during the 2022-2023 academic year, while the sample was comprised of 4<sup>th</sup>-grade students selected from this population. The primary aim in selecting 4<sup>th</sup> grade students was their higher age levels and readiness compared to other grades, which was expected to facilitate a clearer understanding of the scale items. Stratified sampling was preferred in the sample selection process. This method ensured that subgroups within the population were identified and represented in the sample according to their proportions in the population. School administrators and class teachers provided insights regarding the number of students in schools and the socio-economic level of their environments, which helped in stratifying the population. Work groups were then determined using simple random sampling from each stratum of the population. Simple random sampling ensured that every individual in the population had an equal chance of being selected (Çingı, 1994). Thus, the goal was to represent

the population with the obtained sample. Throughout the study, three work groups were involved. The first group, the pilot implementation group, consisted of 50 students, the second group involved 371 students where the Explanatory Factor Analysis [EFA] items were applied, and the third group, comprising 527 students, was used to validate the items identified in the EFA. The research was conducted with 948 out of 3040 4<sup>th</sup> grade students in Kırşehir province.

### **Analysis of Data**

The Attitude Scale was developed using EFA and Confirmatory Factor Analysis [CFA]. While SPSS 25 package program was used for EFA, LISREL 8.80 program was preferred for CFA. For each item in the scale using EFA, item analysis based on the difference between lower and upper group means, item-total correlation, scree plot graph, Kaiser-Mayer-Olkin [KMO] Test, and Barlett Test were conducted to determine the adequacy of the factor analysis of the scale. Factor loadings, factor loading values, and factor loadings of items in the factor structure of the scale, as well as Cronbach's alpha internal consistency coefficient calculations, were performed. With CFA, goodness-of-fit criteria such as Root Mean Square Error of Approximation [RMSEA], Standardized Root Mean Square Residual [SRMR], Goodness of Fit Index [GFI], Adjusted Goodness of Fit Index [AGFI], Comparative Fit Index [CFI], Normed Fit Index [NFI], degrees of freedom, and chi-square goodness-of-fit value were calculated.

### **Ethical Permits of Research:**

In this study, all the rules specified to be followed within the scope of "Higher Education Institutions Scientific Research and Publication Ethics Directive" were complied with. None of the actions specified under the heading "Actions Contrary to Scientific Research and Publication Ethics", which is the second part of the directive, have been taken.

### **Ethics Committee Permission Information:**

Name Name of the committee that made the ethical evaluation = Kırşehir Ahi Evran University Social and Human Sciences Scientific Research and Publication Ethics Committee

Date of ethical review decision = 02.02.2023

Ethics assessment document issue number = 2023/01/27

## **Findings**

The seven-step scale development process proposed by DeVellis (2016) was followed in creating the environmental attitude scale. The obtained results are presented within the framework of these steps.

### **1. Clearly Defining the Subject of**

The aim of developing the environmental attitude scale is to create a valid and reliable measurement tool for determining primary school students' attitudes towards the environment. The preparation process for the scale began with the first step of reviewing the literature related to attitudes, examining attitude-related survey items in the literature, and reviewing attitude scales related to other primary school subjects. Next, the achievements in the primary school curriculum were analyzed, and the environmental-related achievements were identified to create an item pool.

## **2. Creating the Item Pool**

Following the literature review, the step of writing items and creating the item pool was completed. In this step, attitude expressions related to the environment were identified in the achievements of all subjects in the primary school curriculum, relevant achievements were determined, and appropriate items related to the cognitive, affective, and behavioral dimensions of attitude were grouped and written. While creating the item pool, efforts were made to include items in similar proportions related to the cognitive, affective, and behavioral dimensions of attitude. The created items were then evaluated, and each item was carefully examined. Items that did not cover the achievements and were not suitable for the primary school level were removed from the item pool with expert opinion. The final item pool consisted of a total of 50 items.

## **3. Determining the Measurement Structure**

The measurement format chosen for the study is a Likert-type measurement format. Since it is more appropriate to use a three-level or binary Likert scale in scales at the primary school level (Köklü, 1995), a three-level Likert-type measurement format was preferred as the measurement format in the research. Three-level Likert ratings were paired with the 50 items created to determine students' degrees of agreement with environmental attitude statements. These ratings are ["Agree (3)", "Partially Agree (2)", "Disagree (1)"].

## **4. Reviewing the Item Pool by Experts**

To determine content and scope validity, expert opinions should be sought to assess the appropriateness of items in the measurement tool and whether they adequately represent the targeted domain (Erefe, 2002; Karasar, 2016). In this context, draft items were evaluated by 3 primary school teachers, 3 science teachers, and 5 academics in the field of classroom education using the "Primary School Level Environmental Attitude Scale Expert Evaluation Form". After obtaining expert opinions, Lawshe's (1975) technique was used to calculate the Content Validity Ratios [CVR] for the items. Following the evaluations, the Content Validity Index [CVI] value was determined as 1, indicating sufficient agreement among the evaluators. However, five items in the scale were removed based on expert opinions as their CVR value (= .59) was below the established minimum value.

The scale now consists of 45 items, with 15 items targeting cognitive attitudes, 15 items targeting affective attitudes, and 15 items targeting behavioral attitudes. Additionally, two measurement and evaluation experts were consulted to determine whether the attitude items accurately measure students' emotions, thoughts, and behaviors. These experts confirmed that the scale items adequately reflected attitudes and achieved the intended measurement. Furthermore, three language experts examined the scale items to evaluate if there were any deficiencies in terms of language clarity. These experts confirmed that the language used in the items was correct and understandable, without any elements that could lead to misunderstanding or confusion. A pilot test of the 45 item preliminary form was conducted with 50 fourth-grade primary school students. They were asked if there were any items they found difficult to understand, and the duration of the pilot test was determined. Feedback from

the 50 students indicated that there were no items they did not understand, and the average duration of the scale's pilot test was found to be between 25 and 30 minutes.

### **5. Including Verification Items**

In the fifth stage, it has been concluded that there is no need to add any additional verification items regarding determining the final versions of the items.

### **6. Determining Sample Selection for Item Development**

At this stage, the steps of determining a sample size sufficient for the pilot study and conducting the pilot study have been completed. A preliminary application form consisting of 45 items was administered by the researcher to a sample group of 450 students, 250 (56%) of whom were girls and 200 (44%) were boys, selected through simple random sampling from ten different primary schools in Kırşehir city center using stratified sampling. In assessing the adequacy of the dataset, the primary factor considered is the sample size. Kline (1994) suggests that a sample size at least ten times the number of items may be sufficient to reveal reliable factors. Although this number may be reduced to 100 in cases where the factor structure is clear and limited, it is generally emphasized that working with larger samples is more appropriate (as cited in Çokluk et al., 2010). As the sample size increases, the reliability of factor analysis results also increases (Field, 2005). Additionally, it is advocated that in determining the sample size for factor analysis, the Kaiser-Meyer-Olkin test should be conducted, with a value of .60 or higher, and the Bartlett test should be statistically significant (Büyüköztürk, 2019). Finally, according to criteria in the literature, it is suggested that meeting at least two criteria may be appropriate for determining an adequate sample size for factor analysis (Çokluk et al., 2010). In this context, obtaining data from 450 individuals for EFA in the conducted research can be considered to meet the specified criteria.

The Environmental Attitude Scale's structural validity was assessed using the EFA method. The data obtained from 450 students were evaluated to determine if they met the conditions required for EFA. The KMO test yielded a result of .837, and the Bartlett test was found to be statistically significant ( $p=.000$ ). Based on the results of these tests, it can be said that the data set of 450 individuals is sufficient for conducting EFA.

### **7. Evaluation of Substances**

In this stage, validity and reliability calculations were conducted for item assessments. In this context, content, structural, and face validities were analyzed. Content validity expresses how well the measuring tool covers the behaviors it aims to measure, indicating how suitable the measuring tool is for its overall purpose and evaluating the relevance of each item to the purpose (Tekin, 1993; Turgut & Baykul, 2010). For the scope validity of the Environmental Attitude Scale, attitude items in the relevant field were examined, taking into account the general characteristics of environmental education. Additionally, the opinions of experts support the scope validity.

Structural validity refers to the ability of a measuring tool to accurately measure an abstract concept. In other words, structural validity evaluates whether the scores obtained from a test truly measure what the test aims to measure (Büyüköztürk, 2002; Tavşancıl, 2010). Statistical techniques are used to assess structural validity, and these techniques include

methods called factor analyses. Factor analysis can be implemented in two different ways: CFA and EFA (Yurdubakan, 2010). In evaluating the structural validity of the Primary School Level Environmental Attitude Scale, both EFA and CFA methods were utilized.

To determine the reliability of the scale, item analysis and item-total correlation values were examined, and a decision was made on whether any item should be removed from the scale. Subsequently, Cronbach's alpha reliability coefficient was calculated to determine the reliability of the scale.

### ***Item Analysis of the Environmental Attitude Scale***

In the analysis of the items in the Environmental Attitude Scale, item analysis based on the difference between lower and upper group means and item-total correlation analysis methods were used. These analyses were conducted to decide whether each item should be included in the final scale (Tezbaşaran, 1997).

To evaluate the discriminant power of the items in the draft scale, the difference between the mean environmental attitude scores of the lower and upper groups for each item was examined. Initially, the total attitude scores of the students were calculated. Students' environmental attitude scores were ranked from highest to lowest, and the top 27% and bottom 27% groups were identified. From these groups, 122 individuals (27% of the sample) were selected as the lower and upper groups. An independent samples t-test was conducted to examine the difference between the scores of the lower and upper groups. To assess the discriminant potential of the items in the draft scale, a significant difference was observed in terms of environmental attitude score means between the lower and upper groups for each item. It was found that for each item,  $p < .05$ , indicating that the scale items contribute to measuring the intended property. Therefore, no item was removed from the scale.

Each item's item-total correlation value was statistically calculated in the draft scale. It was found that the item-total correlation values for each item ranged from .430 to .654. As emphasized by Büyüköztürk (2019), when item-total correlation coefficients are .30 or higher, it indicates that the items distinguish individuals well. Seçer (2021) also recommends that the item factor loadings be at least .30. When it is assumed that the factors in the measuring tool are unrelated, orthogonal rotation techniques are used; when they are assumed to be related, oblique rotation techniques are used (Seçer, 2021). In this context, considering that the items in the measuring tool represent dimensions of attitude and are related to each other, the promax oblique rotation technique was used in the EFA. Upon examining the item-total correlation value, the explained total variance values, the scree plot, and the component matrix of the Environmental Attitude Scale consisting of 45 items, it was observed that the scale has a multifactorial structure and some items overlap. This indicates the need for further analysis and additional EFAs. Therefore, the EFA was conducted three times. The final EFA resulted in a scale consisting of 3 factors and 17 items. To test the suitability of the 17 item attitude scale for EFA, the KMO Test and Bartlett's Test were applied, and the results are presented in Table 1.



**Table 1.***Results of the Scale's KMO and Bartlett's Test*

Kaiser-Meyer-Olkin sample adequacy measure		.837
Bartlett's sphericity test	chi-square	1270.790
	<i>SD</i>	136
	<i>p</i>	.000

The KMO test resulted in .837. The calculated Bartlett's test result was found to be significant ( $p < .00$ ). If the KMO coefficient is greater than .60 and the Bartlett test is statistically significant, the data is considered suitable for factor analysis (Büyüköztürk, 2019). Looking at the results obtained, it is seen that the data is suitable for factor analysis. The scree plot for the eigenvalues of the factors of the Environmental Attitude Scale is presented in Graph 1.

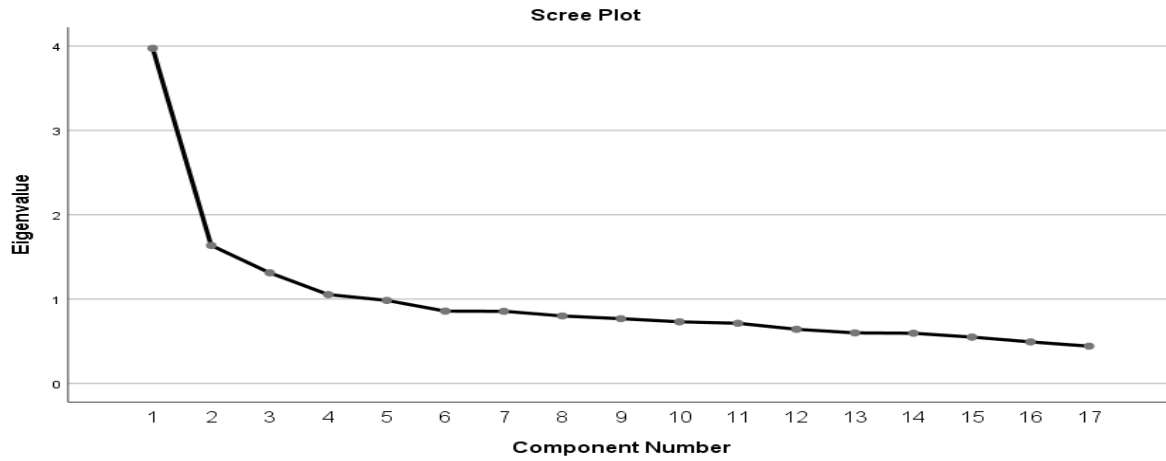
**Graph 1.***Scree Plot Based on Eigenvalues of Factors*

According to Graph 1, breaks were observed at three points. In this context, it can be predicted that the scale may consist of three factors. The results of the rotated component analysis applied to the 17 items in the Environmental Attitude Scale, including item numbers, item contents, common factor variances of items, the number of factors separated, which items are under which factors, and the load values for each item and factor, are presented in Table 2.

**Table 2.**

*Results of Rotated Principal Component Analysis for Factor Analysis*

Item number	Common factor variance (Extraction)	Factor 1	Factor 2	Factor 3
t35	.462	.661		
t24	.445	.651		
t38	.484	.643		
t3	.402	.615		
t10	.478	.580		
t21	.444	.544		
t11	.390	.521		
t9	.444	.507		
t8	.591	.362		
t32	.651		.816	
t31	.613		.759	
t45	.442		.548	
t37	.409		.380	
t23	.474			.669
t6	.435			.643
t18	.443			.609
t16	.350			.420

According to the results in Table 2, the variance of each item in a common factor ranges from .35 to .65, indicating that the items in the scale collectively account for a variance of .30 or higher in a common factor. Therefore, there is no need to remove any items from the scale. Similarly, Kalaycı (2009) emphasized that each factor should have a minimum common variance explanation of .30.

According to Table 2, it was determined that the scale consists of a three-factor structure. The first factor is formed by items t35, t24, t38, t3, t10, t21, t11, t9, and t8, with factor loadings ranging from .36 to .66. The second factor is formed by items t32, t31, t45, and t37, with factor loadings ranging from .38 to .81. The third factor is formed by items t23, t6, t18, and t16, with factor loadings ranging from .42 to .66. To evaluate the relationships between the three factors obtained from the EFA, inter-factor correlation values were calculated. These values are presented in Table 3.

**Table 3.**

*Correlation Results of the Factors*

	Factor1	Factor2	Factor3
Factor1	1		
Factor2	.272**	1	
Factor3	.279**	.166**	1

Table 3 indicates that the three factors comprising the Environmental Attitude Scale are significantly related to each other. The correlation coefficients between the factors range from .16 to .27. According to Seçer (2021), correlation coefficients between factors exceeding .90 indicate multicollinearity problems, which are not recommended. However, the correlation values provided in Table 3 indicate that the scale does not have multicollinearity issues. Additionally, the values in Table 3 also indicate that each sub-factor measures a different characteristic.

The Cronbach's alpha coefficient of internal consistency was calculated to assess the reliability of the Environmental Attitude Scale. This calculation was performed to evaluate both the overall reliability of the scale and the reliability of its subscales. The obtained Cronbach's alpha values are presented in Table 4.

**Table 4.**

*Reliability Coefficients for the Overall Environmental Attitude Scale and Its Subscales*

	Number of items	Cronbach alpha
factor1	9	.732
factor2	4	.660
factor3	4	.613
The overall scale	17	.763

The overall Cronbach's alpha coefficient of internal consistency for the Environmental Attitude Scale was calculated as .76. This value indicates that the scale has the required reliability. A reliability coefficient of .70 or higher is generally considered acceptable (Durmuş et al., 2013; Seçer, 2021; Tezbaşaran, 1997). When examining the subscales of the Environmental Attitude Scale, it can be stated that the reliability coefficient of the first subscale is above .70, indicating that the measurements are reliable. The Cronbach's alpha coefficient of internal consistency for the second and third subscales is found to be .66. Sipahi et al., (2010) have supported the view that a reliability coefficient of .60 or higher is sufficient when the number of items in the scale is low. Therefore, considering that the second and third subscales consist of 4 items each, the values of .66 and .61 can be considered sufficient for reliability.

While naming the 3 factors that emerged as a result of EFA, Tezbaşaran (1997) emphasized the method of recording the particles within the scope of the factor loadings, the distribution of the ratios between the variables depending on their levels, and naming them based on the theoretical framework, and suggested that experts should not be taken into account during the process. The scale development process is to expand the information about the data in the item repository primary school curriculum by considering sensory and behavioral dimensions. The three factors consisting of this dimension were discussed separately, the items were re-read, and the process was named according to the underlying dimension. Two experts were interviewed during and after the naming. Thus, the factors in the Primary School Level Environmental Attitude Scale are named as follows.

Factor 1. Behavioral Tendency Towards the Environment

Factor 2. Affective Tendency Towards the Environment

Factor 3. Cognitive Tendency Towards the Environment

EFA and CFA are two statistical analysis methods that serve different purposes. While EFA is used to discover the factor structure of a scale and to recognize the relationships between the measured variables, CFA is used to evaluate whether a previously used scale fits the actual factor structure when used in the current research and if so, to what extent (Suhr, 2006). In the scale development process, EFA is applied first. This analysis reveals the factor structure of the scale using the data obtained from the data collection process and helps to discover new factors. Then, CFA is conducted to confirm this new factor structure. However, it is important to note that EFA and CFA should not be conducted on the same sample (Suhr,

2006). CFA with the data collected for EFA can only provide confirmation of the discovered structure and may not provide any important information. Therefore, a new data collection process is necessary to retest the factor structure obtained as a result of EFA with new data.

Data was collected from 527 students, 252 (48%) of whom were girls and 275 (52%) were boys, through simple random sampling from six different primary schools in Kırşehir city center determined by a layered sampling method for CFA. The Environmental Attitude Scale, reduced to 17 items from 45 items through EFA, was applied, and CFA was conducted using LISREL 8.80 statistical analysis software on the obtained data.

The overall Cronbach's alpha coefficient for internal consistency of the Environmental Attitude Scale data collected for CFA was calculated as .91, confirming that the scale has the required reliability. Additionally, it was observed that the Cronbach's alpha coefficients for the sub-dimensions of the scale were higher compared to the values obtained from EFA. The Cronbach's alpha coefficient for the first factor increased from .73 to .89, for the second factor from .66 to .73, and for the third factor from .61 to .66.

In CFA, model fit was evaluated using model fit criteria such as RMSEA, SRMR, GFI, AGFI, CFI, and NFI. The RMSEA value was calculated as .049, which according to Browne and Cudeck (1993), indicates a good fit when below .05. The SRMR value for the scale was calculated as .042. Kline (2005) suggests that an SRMR value generally below .10 is considered favorable. Therefore, based on the LISREL data, it can be said that the RMSEA and SRMR values for the scale are favorable.

When evaluating the model fit in CFA, the GFI value was calculated as .96, which is above the recommended threshold of .90 according to Kline (2005). The Adjusted AGFI value was calculated as .95. According to Jöreskog and Sörbom (1993), GFI and AGFI values can range from 0 to 1, with values closer to 1 indicating better model fit. It is also emphasized that these values should not be negative. Raykov and Marcoulides (2006) share a similar view, arguing that GFI and AGFI values between 0 and 1, closer to 1, indicate an appropriate model fit.

Kline (2005) and Raykov and Marcoulides (2006) stated that the NFI value should be close to 1 for an appropriate model fit. According to the measured data, the NFI value was calculated as .94. Furthermore, Byrne (2010), Raykov and Marcoulides (2006) and Brown (2006) argued that the CFI value should also be close to 1. According to the calculation results, the CFI value was calculated as .98. These values show that the model exhibits an acceptable fit. The CFA data of the environmental attitude scale evaluated above were reevaluated in the table below according to the values tabulated by Schumacker and Lomax (2004) and Seğer (2021).

**Table 5.**  
Results of CFA for the Environmental Attitude Scale

Indexes	Perfect fit criterion	Acceptable fit criterion	Finding	Result
X2/sd	0-2.5	2.5-3	2.26	perfect
RMSEA	≤.05	≤.08	.049	perfect
SRMR	≤.05	≤.08	.042	perfect
RMR	≤.05	≤.08	.015	perfectl
NFI	≥.95	≥.90	.94	acceptable
NNFI	≥.95	≥.90	.97	perfect
CFI	≥.95	≥.90	.98	perfect
GFI	≥.90	≥.85	.96	perfect
AGFI	≥.90	≥.85	.95	perfect
IFI	≥.95	≥.90	.98	perfect
RFI	≥.95	≥.90	.93	acceptable

According to Table 5, it is observed that 2 of the data obtained from the Environmental Attitude Scale through CFA are acceptable, and 8 of them have excellent level results. The diagram obtained through CFA is included in Figure 1.

**Figure 1.**  
Fit Diagram Obtained with CFA.

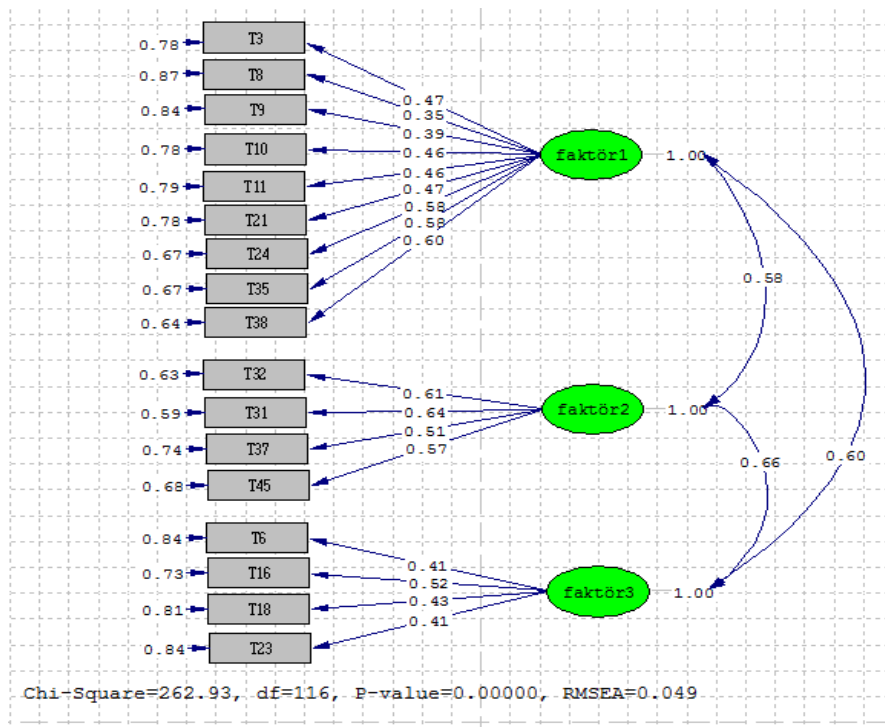

In Figure 1 obtained using the Lisrel 8.80 program, normalized factor values obtained according to CFA results are displayed. These values represent the relationships between observed variables and latent variables. The fact that none of the correlation values between observed variables is above 1 indicates that the relationships between these variables are at an appropriate level. Additionally, according to the diagram, it is concluded that the structure of the Environmental Attitude Scale is significant based on the chi-square fit value ( $\chi^2= 262.93$ ,  $df=116$ ,  $p=.00$ ) obtained from CFA. Considering the sample size, a chi-square value of 262.93

with degrees of freedom (df) of 116 was determined. The ratio  $\chi^2/df$  for model fit is 2.26. These values indicate an acceptable model fit (adapted from Bollen 1989, as cited in Kline, 2005).

## **Discussion and Conclusion**

The aim of the study is to develop a valid and reliable scale to determine primary school students' attitudes towards the environment. In preparing the Environmental Attitude Scale, the scale development stages proposed by DeVellis (2016) were considered. Learning outcomes determined by the Ministry of National Education [MoNE] were examined, and a pool of items was created by reviewing the literature on the subject. The item pool consisted of a total of 50 items. Each item in the item pool was thoroughly examined, and in this context, 50 items were prepared for expert opinions. After obtaining expert opinions, Content Validity Ratios [CVR] for the items were calculated using Lawshe's (1975) technique, and items with CVR values below the specified minimum value ( $=.59$ ) were removed, resulting in a scale ready for pilot testing with 45 items.

The 45-item scale was administered to 50 fourth-grade primary school students, and it was concluded that there were no items that were not understood, and the scale could be administered in 25-30 minutes. It was decided that there was no need to add an additional validation item, and the scale was evaluated for meeting the necessary conditions for EFA. The first factor considered in determining the adequacy of the data set was the sample size. Kline (1994) suggests that a sample size ten times the number of items may be sufficient for reliable factors to emerge. While it is mentioned that this number can be reduced to 100 when the factor structure is clear and limited, it is generally emphasized that working with larger samples is more appropriate (as cited in Çokluk et al., 2010). According to Field (2005), as the sample size increases, the reliability of factor analysis results also increases. Additionally, it is argued that in determining the sample size for factor analysis, the Kaiser-Meyer-Olkin test should be conducted, and the obtained value should be .60 or higher, and the Bartlett test should be statistically significant (Büyüköztürk, 2019). Finally, according to the criteria in the literature, it is stated that meeting at least two criteria may be appropriate for determining an adequate sample size for factor analysis (Çokluk et al., 2010). In this context, it can be stated that obtaining data from 450 individuals for EFA in this study is in line with the specified criteria. The first Kaiser-Mayer-Olkin test result for the data set was found to be .837, and the Bartlett test was statistically significant ( $p=.000$ ). These results indicate that the data set of 450 individuals is of sufficient sample size for EFA.

SPSS 25 statistical calculation software was used for factor analysis of the scale. To evaluate the discriminant power of the items in the draft scale, the difference between the mean scores of the lower group and upper group environmental attitude scores for each item was examined. It was found that there was a significant difference between the mean scores of the lower group and upper group environmental attitude scores. In each item, since the p-value in the t-test results for item means was less than .05, it was concluded that the scale items contribute to measuring the desired characteristic. In the calculation of the item-total correlation value for the draft scale, it was observed that the item-total correlation values for all items in the scale ranged from .430 to .654. Büyüköztürk (2019) emphasizes that when the item-total correlation coefficients are .30 and above, the items distinguish individuals well.

Seçer (2021) suggests that the item factor load should be at least .30, which also supports the reliability of the scale.

Upon examining the item-total correlation and the scree plot graph for the Environmental Attitude Scale consisting of 45 items, it was observed that the scale had a multifactorial structure and some items overlapped with each other. This situation indicated the need for further analysis and more factor analyses [EFA]. Considering that the items in the measurement tool were related to each other in the context of the scale where EFA was performed, the promax oblique rotation technique was used. Promax oblique rotation was applied three times. As a result, a 17 item scale was obtained. The maximum score that can be obtained from the triple Likert scale is 51, and the minimum score is 17. The results of the rotated component analysis conducted on the 17 items of the Environmental Attitude Scale (item number, item content, common factor variance for the items, factors, and factor load values of the items under the factors) were examined, and it was observed that the variance explained together in a common factor ranged from .35 to .65. In this context, since the values of the variance explained together in a common factor were greater than .30, it was understood that none of the items in the scale needed to be removed. Similarly, Kalaycı (2009) states that factors should have a common variance explained of at least .30. It was determined that the scale consisted of three factors, with the first factor being composed of items t35, t24, t38, t3, t10, t21, t11, t9, and t8, and the factor loadings of these items ranged from .36 to .66. It was determined that the second factor was formed by items t32, t31, t45, and t37, with factor loadings ranging from .38 to .81. The third factor was formed by items t23, t6, t18, and t16, with factor loadings ranging from .42 to .66. When the correlation values between the three factors that make up the Environmental Attitude Scale were calculated, it was observed that the three factors were significantly correlated with each other, with values ranging from .16 to .27, indicating a meaningful relationship between the factors. To evaluate the reliability of the Environmental Attitude Scale, Cronbach's alpha internal consistency coefficient was calculated. The Cronbach's alpha internal consistency coefficient for the overall Environmental Attitude Scale was calculated as .76. This value indicates that the scale has the required reliability. A reliability coefficient of .70 and above is considered reliable for measurements (Durmuş et al., 2013; Seçer, 2021; Tezbaşaran, 1997). Looking at the sub-dimensions of the Environmental Attitude Scale, it can be said that the reliability coefficients of the first sub-dimension are above .70, and therefore the measurements are reliable. The Cronbach's alpha internal consistency coefficient for the second and third sub-dimensions was found to be .66. According to Sipahi et al. (2010), when the number of items in the scale is low, a reliability coefficient of .60 and above is considered sufficient. Therefore, considering that the second and third sub-dimensions consist of 4 items, it can be concluded that the values of .66 and .61 are sufficient for reliability.

The three factors identified through the data obtained from EFA were named as Environmental Behavioral Tendencies, Environmental Affective Tendencies, and Environmental Cognitive Tendencies. Considering that the item lengths were also adequate and the reliability of the developed scale was not low, the study proceeded to CFA.

Morgan (1991) acknowledges that attitude includes behavior as a component and that attitudes can predict behaviors. Therefore, it is observed that attitude scales related to the environment are generally developed, and in the development of these scales, only EFA is used (Bogner & Wiseman, 2006; Çınar et al., 2008; Kaiser et al., 1999). However, Şimşek (2007) notes that a scale without a solid theoretical foundation may yield good results in EFA but may not yield the same results in CFA. Therefore, both EFA and CFA were used in the study. It can be said that the scale development study conducted in this context made a significant contribution to the literature. After reducing the Environmental Attitude Scale from 45 items to 17 items based on the results of EFA, the final version of the scale was applied, and CFA was conducted using the data obtained. The Cronbach's alpha internal consistency coefficient for the overall Environmental Attitude Scale based on the data collected for CFA was calculated as .91. This value confirms that the scale has the required reliability. It was observed that the Cronbach's alpha internal consistency coefficients for the sub-dimensions of the environmental attitude scale were higher compared to the values in EFA based on the data collected for CFA. For example, while the Cronbach's alpha internal consistency coefficient for the first factor was .73, it increased to .89, for the second factor from .66 to .73, and for the third factor from .61 to .66. In CFA, the model fit criteria RMSEA value was calculated as .049, SRMR value as .042, and GFI value as .96. The GFI statistic ranges from 0 to 1 and moves inversely with degrees of freedom. That is, as the sample size increases, the GFI value generally tends to increase (Bollen, 1990). Traditionally, a GFI value of .90 is recommended as an acceptable value. However, GFI values up to .95 can be considered for evaluation in cases of small sample sizes or low factor loadings (Shevlin & Miles, 1998). The GFI value of the developed scale is consistent with the literature.

The AGFI value was calculated as .95, the CFI value as .98, and the NFI value as .94. As a result, based on the literature (Schumacker and Lomax, 2004; Seçer, 2021), it is observed that two of the data obtained from CFA for the Environmental Attitude Scale are acceptable, and eight of them are at an excellent level of results.

The goodness-of-fit test result for the structure of the scale obtained through CFA yielded a significant chi-square value ( $\chi^2= 262.93$ ,  $df=116$ ,  $p=.00$ ). It was determined that the chi-square value, which varies according to sample size, was 262.93 with 116 degrees of freedom. The Environmental Attitude Scale, developed through EFA and CFA applications and designed to be applied to elementary school students, has reached its final form.

As a result, it can be said that a scale with appropriate content validity and reliability has been developed in the scale development process. Okur and Yalçın Özdilek (2012) improved the environmental attitude scale with positive and negative attitude sub-factors among teacher candidates. Kılıç and Kan (2020) addressed attitude in their attitude scale towards environmental issues for middle school students, considering positive cognitive, negative cognitive, affective, and behavioral dimensions. Yücel and Özkan (2014) divided attitude into behavior, emotion, thought, and willingness to act in their environmental attitude scale for middle school students. The developed scale is prepared to include the cognitive, affective, and behavioral dimensions of elementary school students' environmental attitudes.



Therefore, this study makes a significant contribution to the field of scale development as it addresses the fundamental three dimensions of attitude.

### **Recommendations**

The developed Primary School Level Environmental Attitude Scale can be used as a data collection tool in future studies by reorganizing it in line with the curriculum and achievements for different grade levels. It can also be revised for different grade levels.

Studies can be conducted to increase the coefficients of items with low factor variance. In addition, arrangements can be made for the factors with fewer items.

Teachers can use the developed scale in their classes to determine the level of their students' attitudes towards the environment, and they can carry out studies to take precautions against the negative attitudes they identify.

The developed scale can be used to conduct studies by scanning environmental attitudes across the province, region or Türkiye. Educational policies can be developed for schools and classes where the scale yields low results. Sharing the results obtained with stakeholders can form the basis for future studies in the field of environment.

Curriculum implementers and curriculum development experts can use this scale to determine the situation and needs, and update the outcomes accordingly.

## References

- Ada, S., Baysal, Z., & Şahenk Erkan, S. (2017). *Çeşitli boyutlarıyla çevre eğitimi* [Environmental education in various dimensions]. Nobel.
- Afacan, Ö., & Demirci Güler, M. P. (2011, April 27-29). *Sürdürülebilir çevre eğitimi kapsamında tutum ölçeği geliştirme çalışması* [Attitude scale development study within the scope of sustainable environmental education]. 2<sup>nd</sup> International Conference on New Trends in Education and Their Implications, Antalya.
- Allport, G. W. (1967). Attitudes. In M. Fishbein (Ed.), *Readings in attitude theory and measurement*. (pp. 3-13). John Wiley & Sons.
- Atasoy, E. (2006). *Çevre için eğitim çocuk doğa etkileşimi* [Education child nature interaction for environment]. Ezgi Kitapevi.
- Bailey, K. D. (1982). *Methods of social research*. Free.
- Bogner, F. X., & Wiseman, M. (2006). Adolescents' attitudes towards nature and environment: Quantifying the 2-MEV model. *Environmentalist*, 26, 247-254.
- Bollen, K. A. (1990). Overall fit in covariance structure models: Two types of sample size effects. *Psychological Bulletin*, 107(2), 256-259.
- Brown, T. A. (2006). *Confirmatory factor analysis for applied research* (2<sup>th</sup> ed.). Guilford.
- Browne, M. W., & Cudeck, R. (1993). Alternative ways of assessing model fit. In K. A. Bollen & J. S. Long (Eds.). *Testing structural equation models*. (pp. 136-162). Sage.
- Büyüköztürk, Ş. (2002). Faktör analizi: Temel kavramlar ve ölçek geliştirmede kullanımı [Factor analysis: Basic concepts and its use in scale improvement]. *Educational Administration: Theory and Practice*, 32(32), 470-483.
- Büyüköztürk, Ş. (2019). *Sosyal bilimler için veri analizi el kitabı: İstatistik, araştırma deseni, SPSS uygulamaları ve yorum* [Data analysis handbook for social sciences: Statistics, research design, SPSS applications and interpretation]. Pegem.
- Byrne, B. M. (2010). *Structural equation modeling with AMOS* (3<sup>th</sup> ed.). Routledge.
- Chepesiuk, R. (2007). Environmental literacy: Knowledge for a healthier public. *Environmental Health Perspectives*, 115(10), 494-499.
- Çabuk, B., & Karacaoğlu, Ö. C. (2003). Üniversite öğrencilerinin çevre duyarlılıklarının incelenmesi [Examining the environmental awareness of university students]. *Ankara University, Journal of Educational of Faculty Sciences*, 36(1-2), 189-198.
- Çınar, D., Doğu, S., & Meydan, A. (2008, May 2-4). *Sınıf öğretmenleri adaylarının çevreye karşı tutumları* [Attitudes of classroom teacher candidates towards the environment]. VII. National Classroom Teacher Education Symposium. Nobel. Ankara.
- Çıngı, H. (1994). *Örnekleme kuramı* [Sampling theory]. Hacettepe University.
- Çokluk, Ö., Şekercioğlu, G., & Büyüköztürk, Ş. (2010). *Sosyal bilimler için çok değişkenli istatistik SPSS ve LISREL uygulamaları* [SPSS and LISREL applications of multivariate statistics for social sciences]. Pegem.
- DeVellis, R. F. (2016). *Scale development: Theory and applications*. Sage.
- Demir, Z. M. (2016). *İlkokul öğrencilerine yönelik çevre tutum ölçeği geliştirme çalışması* [A study of developing an environmental attitude scale for primary school students]. (Publication No: 423568) [Master thesis, Eskisehir Osmangazi University]. National Thesis Center.
- Demirel, Ö. (1993). *Eğitim terimleri sözlüğü* [Dictionary of educational terms]. Pegem.
- Demirkaya, H. (2006). Çevre eğitiminin Türkiye'deki coğrafya programları içerisindeki yeri ve çevre eğitimine yönelik yeni yaklaşımlar [The place of environmental education in geography curricula in Turkey and new approaches to environmental education]. *Firat University Journal of Social Science*, 16(1), 207-222.

- Demirkaya, H., & Genç, H., (2006). Ormana ilişkin tutum ölçeği geliştirilmesi [Development of an attitude scale to measure attitudes toward forest]. *Kastamonu Education Journal*, 14(1), 39-46.
- Doğan, M. (1997). *Çevre eğitimi. Çevre ve insan* [Environmental education. Environment and people]. Ministry of Environment.
- Durmuş, B., Yurtkoru, E. S., & Çinko, M. (2013). *Sosyal bilimlerde SPSS'le veri analizi* [Data analysis with SPSS in social sciences] (5<sup>th</sup> ed.). Beta.
- Erdoğan, İ. (1999) *İşletmelerde davranış* [Behavior in businesses]. Evrim.
- Erefe, İ. (Ed.). (2002). *Veri toplama araçlarının niteliği. Hemşirelikte araştırma ilke süreç ve yöntemleri* [Nature of data collection tools. Research principles, processes and methods in nursing]. (pp. 169-188). HEMAR-GE.
- Erten, S. (2004). Çevre eğitimi ve çevre bilinci nedir, çevre eğitimi nasıl olmalıdır? [What is environmental education and environmental awareness, how should environmental education be?]. *Environment and Human Journal*, 65/66.
- Field, A. (2005). *Discovering statistics using SPSS*. Sage.
- Gök, E., & Afyon, A. (2015). İlköğretim öğrencilerinin çevre bilgisi ve çevresel tutumları üzerine alan araştırması [Field research on primary school students' environmental knowledge and environmental attitudes]. *Turkish Journal of Science Education*, 12(4), 77-93.
- Gökçe, N., Kaya, E., Aktay, S., & Özden, M. (2007). İlköğretim öğrencilerinin çevreye yönelik tutumları [Elementary students' attitudes towards the environment] *Elementary Education Online*, 6(3), 452-468.
- Görümlü, T. (2003). *Liselerde çevreye karşı duyarlılığın oluşturulmasında çevre eğitiminin önemi eğitimi* [Training on the importance of environmental education in creating environmental awareness in high schools]. (Publication No. 140108) [Master thesis, Fırat University]. National Thesis Center.
- Gürkan, T., & Gökçe, E. (1999). *Türkiye'de ve çeşitli ülkelerde ilköğretim: Program, öğrenci, öğretmen* [Primary education in Turkey and various countries: Program, student, teacher]. Siyasal.
- İnceoğlu, M. (1993). *Tutum algı iletişim* [Attitude perception communication]. Verso.
- Jöreskog, K. G., & Sörbom D. (1993). *Lisrel 8: Structural equation modeling with the SIMPLIS command language*. Scientific Software International.
- Kahyaoğlu, M. (2011). Çevre konularıyla ilgili kitap okumaya yönelik tutum ölçeği geliştirme çalışması [Development study of attitude scale towards reading book about environmental issues]. *Elementary Education Online*, 10(3), 1056-1065.
- Kaiser, F. G., Wölfling, S., & Fuhrer U. (1999). Environmental attitudes and ecological behaviour. *Journal of Environmental Psychology*, 19(1), 1-19.
- Kalaycı, Ş. (2009). *SPSS uygulamalı çok değişkenli istatistik teknikleri* [SPSS applied multivariate statistical techniques]. Asil.
- Karasar, N. (2016). *Bilimsel araştırma yöntemi: Kavramlar-ilkeler-teknikler* [Scientific research method: Concepts-principles-techniques] (35<sup>th</sup> ed.). Nobel.
- Kavruk, S. B. (2002) *Türkiye'de çevre duyarlılığının artırılmasında çevre eğitiminin rolü ve önemi* [The role and importance of environmental education in increasing environmental awareness in Turkey]. [Unpublished master thesis]. Gazi University.
- Kılıç, Ç., & Kan, A., (2020). Çevre sorunlarına yönelik tutum ölçeği geliştirme çalışması [A study on developing attitude scale towards environmental problems]. *Abant İzzet Baysal University Faculty of Education Journal*, 20(4), 1676-1690.
- Kline, P. (1994). *An easy guide to factor analysis*. London.
- Kline, R. B. (2005). *Principles and practice of structural equation modeling* (2<sup>th</sup> ed.). Guilford.

- Köklü, N. (1995). Tutumların ölçülmesi ve likert tipi ölçeklerde kullanılan seçenekler [Measurement of attitudes and options used in Likert-type scales]. *Ankara University Journal of Faculty of Educational Sciences*, 28(2), 81-93.
- Lawshe, C. H. (1975). A quantitative approach to content validity. *Personnel Psychology*, 28(4), 563-575.
- Meyerhoff, J. (2006). Stated willingness to pay as hypothetical behaviour: Can attitudes tell us more? *Journal of Environmental Planning and Management*, 49(2), 209- 226.
- Morgan, C. T. (1991). *Psikolojiye giriş* [Introduction to psychology] (8<sup>th</sup> ed.). (H. Arıcı, O. Aydın, et al., Trans.). Hacettepe University Psychology Department.
- Moseley, C. (2000). Teaching for environmental literacy. *Clearing House*, 74(1), 23– 24.
- Okur, E., & Yalçın-Özdilek, Ş. (2012). Environmental attitude scale developed by structural equation modeling. *Elementary Education Online*, 11(1), 85-94.
- Raykov, T., & Marcoulides, G. A. (2006). *A first course in structural equation modeling*. Lawrence Erlbaum Associates.
- Schumacker, R. E., & Lomax, R. G. (2004). *A beginner's guide to structural equation modeling*. Psychology.
- Seçer, İ. (2021). *SPSS ve Lisrel ile pratik veri analizi: Analiz ve raporlaştırma* [Practical data analysis with SPSS and Lisrel: Analysis and reporting]. Anı.
- Shevlin, M., & Miles, J. N. (1998). Effects of sample size, model specification and factor loadings on the GFI in confirmatory factor analysis. *Personality and Individual Differences*, 25(1), 85-90.
- Sipahi, B., Yurtkoru, E. S., & Çinko, M. (2010). *Sosyal bilimlerde SPSS'le veri analizi* [Data analysis with SPSS in social sciences]. Beta.
- Suhr, D. D. (2006). *Exploratory or confirmatory factor analysis?* (pp. 1-17). SAS Institute.
- Şimşek, Ö. F. (2007). *Yapısal eşitlik modellemesine giriş, temel ilkeler ve LISREL uygulamaları* [Introduction to structural equation modeling, basic principles and LISREL applications]. Ekinoks.
- Tavşancıl, E. (2010). *Tutumların ölçülmesi ve SPSS ile veri analizi* [Measurement of attitudes and data analysis with SPSS] (3<sup>th</sup> ed). Nobel.
- Tekin, H. (1993). *Eğitimde ölçme ve değerlendirme* [Measurement and evaluation in education]. Yargı.
- Tezbaşaran, A. (1997). *Likert tipi ölçek geliştirme kılavuzu* [Likert type scale development guide]. Turkish Psychologists Association.
- Tuncer, A. (2021). *Öğretmen adaylarının çevresel tutumunu belirlemek amacıyla geliştirilen Çevre'ye Yönelik Tutum Ölçeği: Ordu Üniversitesi örneği* [Attitude Towards the Environment Scale developed to determine the environmental attitudes of pre-service teachers: The case of Ordu University]. (Publication No. 10432725) [Master thesis, Ordu University]. Ordu University Open Access System.
- Turgut, M. F., & Baykul, Y. (2010). *Eğitimde ölçme ve değerlendirme* [Measurement and evaluation in education]. Pegem.
- Yalçınkaya, E. (2012). İlköğretim 6. sınıf öğrencilerinin çevre sorunları farkındalık düzeyleri [The levels of primary 6<sup>th</sup> grade students' awareness of environmental issues]. *Marmara Geographical Review*, (25), 137-151.
- Yaşaroğlu, C., & Akdağ, M. (2013). İlköğretim birinci kademe için çevreye yönelik tutum ölçeği: Geçerlik ve güvenirlik çalışması [Scale of first stage elementary school students' attitudes towards environment: The study of validity and reliability]. *Adiyaman University Journal of Social Sciences*, (13), 253-275.
- Yurdubakan, İ. (2010) Eğitimde kullanılan ölçme araçlarının nitelikleri [Qualifications of measurement tools used in education]. In M. Gömleksiz & S. Erkan (Eds.). *Eğitimde ölçme ve değerlendirme* [Measurement and evaluation in education]. (pp. 33-66). Nobel.

Yücel, E. Ö., & Özkan, M. (2014). Ortaokul öğrencilerine yönelik çevresel tutum ölçeği geliştirilmesi [Development of environmental attitudes scale for secondary school students]. *Journal of Uludag University Faculty of Education, 27(1), 27-48.*

## **BIOGRAPHICAL NOTES**

### **Contribution Rate of Researchers**

Author 1: 50%

Author 2: 50%

### **Conflict Statement**

There is no conflict of interest that the authors will declare in the research.



## İlkokul Düzeyi Çevre Tutum Ölçeği Geliştirme Çalışması

### Özet

Bu araştırmada, ilkokul öğrencilerinin çevreye yönelik tutum düzeylerini belirleyebilecek geçerli ve güvenilir bir ölçme aracının geliştirilmesi amaçlanmıştır. Nicel araştırma desenin benimsendiği araştırma tarama çalışması niteliğindedir. Araştırma 2022-2023 eğitim öğretim yılında Kırşehir ilinde yer alan ilkokullarda 948 öğrencinin katılımıyla yürütülmüştür. Araştırmada, likert tipi ölçek geliştirme modeli kullanılmıştır. Ölçme aracında yer alan maddelerin birbiriyle ilişkili olduğu düşünülerek Açıklayıcı (Explanatory) Faktör Analizinde [AFA] promax eğik döndürme tekniği kullanılmıştır. Üç kez uygulanan döndürme tekniği sonucunda, 3 alt faktörden oluşan, 17 maddelik ölçek elde edilmiştir. Ölçeğin Kaiser-Mayer-Olkin [KMO] Testi sonucu .837 olarak hesaplanmıştır. Hesaplanan Bartlett Testi sonucunun ise ( $p < .00$ ) anlamlı olduğu tespit edilmiştir. Geliştirilen veri toplama aracının geçerlik-güvenirlik analizleri sonucunda açıklayıcı faktör analizinde .76 olarak hesaplanan Cronbach alfa iç tutarlık katsayısının doğrulayıcı faktör analizinde .91 olarak artış gösterdiği görülmüştür. Araştırma sonucunda ilkokul öğrencilerinin çevreye yönelik tutum düzeylerini belirleyebilecek geçerli ve güvenilir bir ölçme aracı geliştirilmiştir. Geliştirilen ölçek farklı sınıf düzeyleri için müfredat ve kazanımlar doğrultusunda revize edilebilir.

**Anahtar Kelimeler:** Çevre, ilkokul, ölçek geliştirme, tutum.

### Giriş

İnsanoğlu varoluşundan itibaren çevresiyle etkileşim içinde olmuş hem çevresini etkilemiş hem de ondan etkilenmiştir. Çevre, canlıların yaşam alanıdır ve insanların sosyal, biyolojik, ekonomik, fiziksel ve kültürel ilişkilerini sürdürdükleri bir ortamdır. Bu ortam, insanların iletişim kurdukları, kendilerini gerçekleştirdikleri ve iç dünyalarıyla bütünleştikleri yerdir. Çevre, sadece fiziksel bir mekân değil, kişisel ve psikolojik açıdan da önemlidir. Çevre ile etkileşimler bireyin kendini gerçekleştirmesinde önemli rol oynar (Ada vd., 2017; Çabuk & Karacaoğlu, 2003; Kavruk, 2002; Yalçınkaya, 2012). Bireylerin çevre üzerindeki faaliyetleri toplumsal çevreyi de etkiler. Bu nedenle bireylerin çevre üzerindeki etkilerinin farkında olmaları önemlidir ve bu farkındalık çevre eğitimi ile sağlanabilir. Çevre eğitimi, bireylerin çevreyle ilgili durumlarda bilgili, çözüm odaklı ve sorumluluk sahibi olmalarını sağlar ve yaşam boyu devam eden disiplinler arası bir yaklaşımdır (Chepesiuk, 2007; Moseley, 2000). Çevre eğitiminin tüm boyutlarında, çevre çalışmalarına erken yaşlarda başlamanın önemi vurgulanır. Erken yaşlarda başlayan çevre eğitimi, bireylerin çevresel tutum ve farkındalıklarının oluşmasında büyük önem taşır (Demirkaya, 2006; Erten, 2004; Gök & Afyon, 2015; Gökçe vd., 2007).

Tutum, bireyleri belirli davranışlara yönlendiren, öğrenme sonucu oluşan eğilimlerdir (Demirel, 1993). Öğrenmenin kritik döneminin temel eğitim düzeyi olduğu düşünüldüğünde, çevre eğitiminin erken yaşlarda verilmesi bireylerde çevre duyarlılığı ve olumlu tutumlar geliştirmede etkilidir. Tutum bileşenleri bilişsel, duygusal ve davranışsal boyutlardan oluşur (Morgan, 1991). Bu bileşenlerin birbirleriyle iç tutarlılığı vardır. Bireyin sahip olduğu bilgiler

olumlu yaklaşıma neden oluyorsa "bilişsel bileşen", olumlu duygulara sahip olması "duygusal bileşen", bu duygu ve düşüncelerini ifade etmesi "davranışsal bileşen" olarak adlandırılır. Tutumlar, biliş-duygu-davranış eğiliminin harmanlanmasıyla oluşan bir bütündür (İnceoğlu, 1993). Araştırmalar, bireylerin davranışları doğrudan gözlemlenebilir olsa da tutumlarını ölçmek için bir ölçeğe ihtiyaç duyulduğunu göstermektedir (Çınar vd., 2008; Meyerhoff, 2006). Bu ihtiyaçtan yola çıkarak bu araştırma, ilkökul öğrencilerinin çevreye yönelik tutumlarını belirlemek için geçerli ve güvenilir bir ölçek geliştirmeyi amaçlamaktadır. Alanyazında, ilkökul birinci kademe (Demir, 2016; Yaşaroğlu ve Akdağ, 2013) ve ikinci kademe öğrencilerine (Demirkaya ve Genç, 2006; Kılıç ve Kan, 2020) yönelik çevre tutum ölçekleri geliştirilmiş; öğretmen adaylarının çevreye yönelik tutumlarına dair ölçekler (Afacan ve Demirci Güler, 2011; Kahyaoğlu, 2011; Okur ve Yalçın Özdilek, 2012; Tuncer, 2021) bulunmaktadır. Ancak, ilkökul müfredatının tamamını ele alıp çevre ile ilgili kazanımları belirleyen ve tutumun üç boyutunu baz alarak geliştirilmiş bir ölçek mevcut değildir. Bu nedenle, araştırmanın alanyazına önemli bir katkı sağladığı düşünülebilir. Ölçeğin geliştirilmesi sürecinde tutumun boyutları ve ilkökul müfredatında yer alan çevre ile ilişkili kazanımlar doğrultusunda ölçek maddeleri belirlenmiştir. Bu bağlamda "İlkökul öğrencilerinin çevreye ilişkin tutum düzeylerini belirlemeye yönelik bir ölçek nasıl geliştirilebilir?" sorusuna cevap aranmıştır.

## **Yöntem**

### **Araştırmanın Modeli**

Araştırmada nicel araştırma yöntemlerinden biri olan genel tarama modellerinden tekil tarama modeli benimsenmiştir. Tekil tarama modeliyle öğrencilerin güncel durumları belirlenmeye çalışılmıştır. Tekil tarama modeli, evrenin bütünü yerine belirli bir grup veya alt küme üzerinden evren hakkında genel bir anlayışa varma amacıyla kullanılmıştır (Bailey, 1982).

### **Evren ve Örneklem**

Araştırmanın evrenini 2022-2023 eğitim öğretim yılında Kırşehir ilinde ilkökullarda öğrenim gören öğrenciler, örneklemini ise; bu evrenden belirlenen 4. sınıf öğrencileri oluşturmuştur. İlkökul 4. sınıflarının belirlenmesindeki temel amaç yaş düzeylerinin ve hazırbulunuşluklarının diğer sınıflara göre daha yüksek olmasıdır. Bu sayede ölçek maddelerinin daha net anlaşılabilirliği düşünülmüştür. Örneklem alımında tabakalı örnekleme yöntemi tercih edilmiştir. Bu araştırmada tabakalı örnekleme yöntemi ile evrendeki alt grupların belirlenip bunların evren büyüklüğü içindeki oranlarıyla örnekleme temsil edilmeleri sağlanmıştır. Araştırmada okullar, öğrenci sayıları ve buldukları çevrenin sosyo ekonomik düzeyleri bakımından okul yöneticilerinden ve sınıf öğretmenlerinden alınan görüşler doğrultusunda tabakalara ayrılmıştır. Tabakalara ayrılan evren üzerinden basit tesadüfi örnekleme yöntemiyle çalışma grupları belirlenmiştir. Basit tesadüfi örnekleme yöntemi ile belirlenen her bir evrendeki bireylerin seçilme şansının eşit olasılıkta olması (Çingı, 1994) ulaşılan örnekleme evreni temsil etmek hedeflenmiştir.



## **Verilerin Analizi**

Tutum ölçeğinin geliştirilmesinde Açıklayıcı Faktör Analizi [AFA] ve Doğrulayıcı Faktör Analizi'nden [DFA] yararlanılmıştır. AFA için SPSS 25 paket programı kullanılırken DFA için LISREL 8.80 programı tercih edilmiştir. AFA ile ölçekte bulunan her madde için alt ve üst grup ortalamaları farkına dayalı madde analizi, madde-toplam korelasyonu, çizgi (scree plot) grafiği, ölçeğin faktör analizi yeterliliğini belirlemek amacıyla Kaiser-Mayer-Olkin [KMO] Testi ve Barlett Testi, ölçeğin faktör yapısını belirtmek için faktörlerin yük hesaplamaları, faktörlerin yük değerleri ve ölçekte bulunan maddelerin faktör çatısında almış olduğu yük değerleri, Cronbach alfa iç tutarlık katsayı hesaplamaları yapılmıştır. DFA ile; veri uygunluk ölçütlerinden Root Mean Square Error of Approximation [RMSEA], Standardized Root Mean Square Residual [SRMR], Goodness of Fit Index [GFI], Adjusted Goodness of Fit Index [AGFI], Comparative Fit Index [CFI], Normed Fit Index [NFI] değerleri, serbestlik değeri ve ki-kare uyum değeri hesaplanmıştır.

### **Araştırmanın Etik İzinleri:**

Bu çalışmada "Yükseköğretim Kurumları Bilimsel Araştırma ve Yayın Etiği Yönergesi" kapsamında uyulması gerektiği belirtilen tüm kurallara uyulmuştur. Yönergenin ikinci bölümü olan "Bilimsel Araştırma ve Yayın Etiğine Aykırı Eylemler" başlığı altında belirtilen eylemlerin hiçbiri gerçekleştirilmemiştir.

### **Etik Kurul İzin Bilgileri:**

Etik değerlendirmeyi yapan kurulun adı = Kırşehir Ahi Evran Üniversitesi Sosyal ve Beşerî Bilimler Bilimsel Araştırma ve Yayın Etik Kurulu

Etik kurul etik inceleme karar tarihi= 02.02.2023

Etik değerlendirme belgesi konu numarası= 2023/01/27

## **Bulgular**

Çevre tutum ölçeği oluşturulurken, DeVellis (2016) tarafından önerilen yedi aşamalı ölçek geliştirme basamakları temel alınmıştır. Elde edilen sonuçlar bu adımlar çerçevesinde sunulmuştur.

### **1. Ölçülecek Konunun Açıkça Belirlenmesi**

Ölçek hazırlığı sürecinde ilk adım olarak tutumla ilgili alanyazının taranması, literatürde yer alan tutum içerikli anket maddelerinin gözden geçirilmesi ve diğer ilkökul dersleriyle ilgili literatürde yer alan tutum ölçeklerinin incelenmesi gerçekleştirilmiştir. Ardından ilkökul müfredatındaki kazanımlar analiz edilmiş ve çevre ile ilgili kazanımlar madde havuzu oluşturmak için belirlenmiştir.

### **2. Madde Havuzunu Oluşturma**

Literatür incelemesinin ardından, maddeleri yazma ve madde havuzu oluşturma adımı gerçekleştirilmiştir. Bu adımda, ilkökul müfredatında yer alan bütün derslerin kazanımlarında çevreye yönelik tutum ifadeleri belirlenmiş, ilgili kazanımlar tespit edilmiş ve tutumun bilişsel, duyuşsal ve davranışsal boyutuna ilişkin uygun maddeler gruplandırılarak yazılmıştır. Madde havuzu oluşturulurken tutumun bilişsel, duyuşsal ve davranışsal boyutuna ilişkin benzer

oranlarda maddeye yer verilmeye çalışılmıştır. Oluşturulan maddeler daha sonra değerlendirilmiş ve her bir madde dikkatlice incelenerek kazanımları kapsamayan ve ilkökul düzeyine uygun görülmeyen maddeler uzman görüşü alınarak madde havuzundan çıkarılmıştır. Oluşturulan madde havuzu son haliyle toplamda 50 maddeyi içermiştir.

### **3. Ölçme Düzenini Belirleme**

Çalışma ilkökul düzeyinde gerçekleştirildiğinden ölçüm formatı olarak 3'lü likert tipi tercih edilmiştir.

### **4. Uzmanlar Tarafından Madde Havuzunun Gözden Geçirilmesi**

Hazırlanan taslak maddelerin değerlendirilmesi amacıyla 3 sınıf öğretmeni, 3 fen bilimleri öğretmeni ve sınıf eğitimi alanında 5 akademisyene "İlkokul Düzeyi Çevre Tutum Ölçeği Uzman Değerlendirme Formu" iletilmiştir. Uzman görüşleri alındıktan sonra, Lawshe (1975) tekniği kullanılarak maddelere ilişkin Kapsam Geçerlik Oranları [KGO] hesaplanmıştır. Değerlendirmeler sonucunda, Kapsam Geçerlik İndeksi [KGI] değeri 1 olarak belirlenmiş ve bu da değerlendiriciler arasında yeterli uyum olduğunu göstermiştir. Bununla birlikte hazırlanan ölçekte yer alan 5 madde uzman görüşleri doğrultusunda KGO değerinin (= .59) belirlenen minimum değerinin altında olması sebebiyle ölçekten çıkarılmıştır. Bu durumda ölçekte 45 madde kalmıştır. Kalan 45 maddenin 15 maddesinin bilişsel, 15 maddesinin duyuşsal, 15 maddesinin de davranışsal tutum ifadelerine yönelik olduğu belirlenmiştir.

### **5. Doğrulama Maddelerini Dâhil Etme**

Beşinci aşamada, maddelerin nihai hallerini belirlenmesi konusunda herhangi bir ek doğrulama maddesinin eklenmesine gerek olmadığı kanısına varılmıştır.

### **6. Madde Geliştirme için Örneklem Seçimini Belirleme**

Bu aşamada, ön uygulama için yeterli olabilecek örneklemin belirlenmesi ve ön uygulamanın gerçekleştirilmesi adımları tamamlanmıştır.

### **7. Maddelerin Değerlendirilmesi**

Madde değerlendirmeleri için bu aşamada geçerlik ve güvenilirlik hesaplamaları yapılmıştır. Bu bağlamda öncelikle kapsam, yapı ve görünüş geçerlikleri analiz edilmiştir. İlkokul Düzeyi Çevre Tutum Ölçeğinin geçerliğini değerlendirmek için AFA'nın yanı sıra DFA yöntemlerinden yararlanılmıştır. Ölçeğin güvenilirliğini belirlemek için madde analizi ve madde-toplam korelasyonu değerleri incelenmiş ve ölçekten herhangi bir madde çıkarılıp çıkarılmayacağına karar verilmiştir. Ardından ölçeğin güvenilirliğini belirlemek için Cronbach alfa güvenilirlik katsayısı hesaplanmıştır.

### ***Çevre Tutum Ölçeğinin Madde Analizi***

Taslak ölçekte yer alan maddelerin ayırt edicilik potansiyelini değerlendirmek amacıyla, her bir madde için alt grup ile üst grup arasında çevre tutum puanları ortalamaları açısından anlamlı bir farklılık gözlemlenmiştir. Her bir madde için  $p < .05$  olduğu görülmüş olup bu da ölçek maddelerinin ölçülmek istenen özelliğin ölçülmesine katkıda bulunduğunu göstermektedir. Böylece ölçekten herhangi bir madde çıkarılmamıştır. KMO Testi sonucu .837 olarak hesaplanmıştır. Hesaplanan Bartlett Testi sonucu ise ( $p < .00$ ) anlamlı olduğu tespit edilmiştir.

Çevre tutum ölçeğinin güvenilirliğini değerlendirmek için Cronbach alfa iç tutarlık katsayısı hesaplanmıştır. Bu hesaplama hem ölçeğin genel güvenilirliğini hem de alt boyutlarına ait güvenilirliği değerlendirmek amacıyla yapılmıştır. Çevre tutum ölçeğinin genel Cronbach alfa iç tutarlık katsayısı .76 olarak hesaplanmıştır. Bu değer, ölçeğin gereken güvenilirliğe sahip olduğunu göstermektedir.

AFA sonucunda ortaya çıkan 3 faktör isimlendirilirken Tezbaşaran (1997), maddelerin taşıdığı faktör yükleri kapsamında belirlenen maddelerin, faktörler arasındaki ilişkilerin düzeyine bağlı olarak düzenlenmesi, faktörlerin teorik çerçeveye dayalı olarak adlandırılması gerektiğini vurgulamış ve sürecin yürütülmesi sırasında konuda uzman kişilerin görüşlerinin dikkate alınmasını önermiştir. Ölçek geliştirme sürecinde madde havuzu ilkökul dersleri müfredatında yer alan kazanımlar doğrultusunda tutumun bilişsel, duyuşsal ve davranışsal boyutları ele alınarak oluşturulmuştur. Bu bağlamda ölçekte oluşan üç faktör ayrı ayrı ele alınmış, maddeler yeniden okunmuş, sürecin başlangıcında temel alınan tutumun boyutlarına göre isimlendirme yoluna gidilmiştir. İsimlendirme yapılırken ve yapıldıktan sonra iki uzman görüşü alınmıştır. Böylece İlkokul Düzeyi Çevre Tutum Ölçeğindeki faktörler aşağıdaki gibi isimlendirilmiştir.

Faktör 1. Çevreye Yönelik Davranışsal Eğilim

Faktör 2. Çevreye Yönelik Duyuşsal Eğilim

Faktör 3. Çevreye Yönelik Bilişsel Eğilim

DFA için Kırşehir il merkezindeki okullardan tabakalı örneklem yöntemiyle belirlenen altı farklı ilkokuldan basit seçkisiz örnekleme yoluyla 252'si (%48) kız ve 275'i (%52) erkek olmak üzere toplam 527 öğrenciden veri toplanmıştır. AFA sonucunda 45 maddeden 17 maddeye düşen Çevre Tutum Ölçeği son hali ile uygulanmış ve elde edilen veriler üzerinde LISREL 8.80 istatistik hesaplama programı kullanılarak DFA yapılmıştır.

Çevre Tutum Ölçeğinin DFA için toplanan verilerine göre genel Cronbach alfa iç tutarlık katsayısı .91 olarak hesaplanmıştır. Bu değer, ölçeğin gereken güvenilirliğe sahip olduğunu doğrulamaktadır. Ayrıca, DFA için toplanan verilere göre ölçeğin alt boyutlarına ait Cronbach alfa iç tutarlık katsayılarının AFA'daki değerlere kıyasla daha yüksek olduğu gözlemlenmiştir. Birinci faktörün Cronbach alfa iç tutarlık katsayısı .73 iken .89'a, ikinci faktörün katsayısı .66 iken .73'e ve üçüncü faktörün katsayısı .61 iken .66'ya yükselmiştir.

DFA'da, modelin uygunluğunu değerlendirmek için RMSEA, SRMR, GFI, AGFI, CFI, NFI gibi model uygunluk ölçütleri kullanılmıştır. RMSEA değeri .049 hesaplanmıştır. Browne ve Cudeck'e (1993) göre, RMSEA değerinin .05'in altında olması iyi bir uyum gösterdiğini belirtmektedir. Ölçeğin SRMR değeri .042 olarak hesaplanmıştır. Kline'a (2005) göre SRMR değerinin genel olarak .10'un altında olması olumlu olarak kabul edilmektedir. Bu bağlamda LISREL verilerine göre ölçeğe ait RMSEA ve SRMR değerinin olumlu değerler aldığı söylenebilir.

DFA' da modelin uygunluğu baz alındığında .90 değerinin üzerinde olması gereken (Kline, 2005) GFI değeri .96 olarak hesaplanmış, AGFI değeri ise .95 olarak hesaplanmıştır. Jöreskog ve Sörbom'a (1993) göre, GFI ve AGFI değerlerinin modelin uyumunu yansıttığında

0 ile 1 arasında bir değer alabileceği ve 1'e daha yakın olmasının istenilen durum olduğu belirtilmektedir. Ayrıca, bu değerlerin negatif olmaması gerektiği vurgulanmaktadır. Raykov ve Marcoulides (2006) ise aynı görüşü paylaşarak GFI ve AGFI değerlerinin 0 ile 1 arasında olması ve 1'e yakın olması durumunda uygun bir model uyumu olduğunu savunmuşlardır.

Kline (2005) ve Raykov ve Marcoulides (2006), uygun bir model uyumu için NFI değerinin 1'e yakın olması gerektiğini ifade etmişlerdir. Ölçülen verilere göre NFI değeri .94 olarak hesaplanmıştır. Ayrıca Byrne (2010), Raykov ve Marcoulides (2006) ve Brown (2006), CFI değerinin de 1'e yakın olması gerektiğini savunmuşlardır. Hesaplama sonuçlarına göre CFI değeri .98 olarak hesaplanmıştır. Bu değerler, modelin kabul edilebilir bir uyum sergilediğini göstermektedir. Çevre tutum ölçeğinin yukarıda değerlendirilen DFA verileri Schumacker ve Lomax (2004) ve Seçer (2021) tarafından tablolaştırılan değerlere göre aşağıdaki tabloda belirtilip yeniden değerlendirilmiştir.

## **Tartışma ve Sonuç**

Morgan (1991), tutumun bir bileşenin de davranış olduğu ve tutumların davranışları öngörebileceği kabul edilmektedir. Bu nedenle çevreye ilişkin genellikle tutum ölçeklerinin geliştirildiği ve bu ölçeklerin geliştirilmesinde sadece AFA'nın kullanıldığı gözlenmektedir (Bogner & Wiseman, 2006; Çınar vd., 2008; Kaiser vd., 1999). Ancak Şimşek (2007), sağlam bir teorik temele sahip olmayan bir ölçeğin, AFA'da iyi sonuçlar verse bile aynı sonucun DFA'dan elde edilemeyeceğini belirtmektedir. Bu nedenle, araştırmada hem AFA hem DFA kullanılmıştır. Yürütülen ölçek geliştirme çalışmasının bu bağlamda alanyazına önemli bir katkı sağladığı söylenebilir. AFA sonucunda 45 maddeden 17 maddeye düşen Çevre Tutum Ölçeği son hali ile uygulanmış ve elde edilen veriler üzerinde LISREL 8.80 istatistik hesaplama programı kullanılarak DFA yapılmıştır. Çevre tutum ölçeğinin DFA için toplanan verilerine göre geneline ait Cronbach alfa iç tutarlık katsayısı .91 olarak hesaplanmıştır. Bu değer, ölçeğin gereken güvenilirliğe sahip olduğunu doğrulamaktadır. DFA için toplanan verilere göre çevre tutum ölçeğinin alt boyutlarına ait Cronbach alfa iç tutarlık katsayılarının AFA'daki değerlere kıyasla daha yüksek olduğu gözlemlenmiştir. Örneğin, birinci faktörün Cronbach alfa iç tutarlık katsayısı .73 iken .89'a, ikinci faktörün katsayısı .66 iken .73'e ve üçüncü faktörün katsayısı .61 iken .66'ya yükselmiştir. DFA'da, yapının uygunluğu için model uygunluk ölçütlerinden RMSEA değeri .049, SRMR değeri .042 olarak hesaplanmıştır. GFI değeri .96 olarak hesaplanmıştır. GFI istatistiği 0 ile 1 arasında değer alır ve serbestlik derecesiyle ters orantılı olarak hareket eder. Yani, örnek büyüklüğü arttıkça GFI değeri genellikle artma eğilimindedir (Bollen, 1990). Geleneksel olarak, .90 GFI değeri kabul edilebilir bir değer olarak önerilmektedir. Ancak, küçük örneklem büyüklükleri veya düşük faktör yükleri gibi durumlarda, değerlendirme yapmak için .95'e kadar olan GFI değerleri dikkate alınabilir (Shevlin & Miles, 1998). Geliştirilen ölçeğin GFI değeri literatürle uyumludur.

AGFI değeri .95, CFI değeri .98, NFI değeri ise .94 hesaplanmıştır. Sonuç olarak çevre tutum ölçeğinin DFA ile elde edilen verilerinin alan yazına göre (Schumacker ve Lomax, 2004; Seçer, 2021) 2 tanesinin kabul edilebilir ve 8 tanesinin de mükemmel düzeyde sonuçlara sahip olduğu görülmüştür.

DFA sonucunda ölçeğin yapısının ki-kare uyum değerinin ( $X^2 = 262.93$ ,  $sd = 116$ ,  $p = .00$ ) anlamlı olduğu tespit edilmiştir. Örneklem büyüklüğüne göre değişiklik gösteren  $X^2$  değerinin 262.93, serbestlik derecesinin [df] 116 olduğu belirlenmiştir. AFA ve DFA uygulamalarıyla geliştirilen ve ilkokul düzeyi öğrencilere uygulanabilecek veri toplama aracı olan Çevre Tutum Ölçeğinin son haline ulaşılmıştır.

Sonuç olarak ölçek geliştirme sürecinde kapsam geçerliliği ve güvenilirliği uygun olan bir ölçek geliştirildiği söylenebilir. Okur ve Yalçın Özdilek (2012) öğretmen adaylarıyla yürüttükleri çevresel tutum ölçeğini olumlu ve olumsuz tutum alt faktörlerinde geliştirmişlerdir. Kılıç ve Kan (2020) ise ortaokul öğrencilerine yönelik geliştirdiği çevre sorunlarına yönelik tutum ölçeğinde tutumu, olumlu bilişsel, olumsuz bilişsel, duyuşsal ve davranışsal olarak dört boyutta ele almıştır. Yücel ve Özkan'ın (2014) ortaokul öğrencilerine ilişkin geliştirmiş oldukları çevre tutum ölçeğinde ise tutumu davranış, duygu, düşünce ve eylemde bulunmaya isteklilik olarak faktörlere ayırmışlardır. Geliştirilen bu ölçek ilkokul öğrencilerinin çevre tutumlarını bilişsel, duyuşsal ve davranışsal boyutlarını içerecek şekilde hazırlanmıştır. Bu nedenle, yapılan çalışma tutumun temel üç boyutunu ele aldığından ölçek geliştirme alanında önemli bir katkı sağlamaktadır.

## **Öneriler**

Geliştirilen İlkokul Düzeyi Çevre Tutum Ölçeği farklı sınıf düzeyleri için müfredat ve kazanımlar doğrultusunda yeniden düzenlenerek gelecek çalışmalarda veri toplama aracı olarak kullanılabilir. Ayrıca farklı sınıf düzeyleri için revize edilebilir.

Faktör varyansı düşük olan maddelerin katsayılarını arttırmak için çalışmalar yapılabilir. Ayrıca madde sayısı az olan faktörlere ilişkin düzenlemeler yapılabilir.

Öğretmenler, geliştirilen ölçeği, öğrencilerinin çevreye yönelik tutum düzeylerini belirlemek amacıyla sınıflarında kullanabilir, belirledikleri olumsuz tutumlara ilişkin önlem almaya yönelik çalışmalar yapabilirler.

Geliştirilen ölçek, il, bölge veya Türkiye genelinde çevresel tutumları tarayarak çalışmalar yapmak amacıyla kullanılabilir. Yapılan taramalarda, ölçeğin düşük sonuçlar verdiği okullar ve sınıflara yönelik eğitim politikaları geliştirilebilir. Elde edilen sonuçların paydaşlarla paylaşılması çevre alanında yapılacak çalışmalara temel oluşturabilir.

Öğretim programları uygulayıcıları ve program geliştirme uzmanları, durumu belirlemek ve ihtiyaçları tespit etmek amacıyla bu ölçeği kullanabilir, bu doğrultuda kazanımları güncelleyebilirler.

### Ek 1: İlkokul Düzeyi Çevre Tutum Ölçeği

Sıra Numarası		(3) Katılıyorum	(2) Kısmen katılıyorum	(1) Katılmıyorum
1	Okulda su kaynaklarımı boşa harcamamaya özen gösteririm.	③	②	①
2	Gelecekte temiz içme suyu bulmakta zorlanacağımızı düşünürüm.	③	②	①
3	Elektrikli aletlerin kullanılmadığında fişten çekilmesini uygun bulurum.	③	②	①
4	Çevre konusunda arkadaşlarımla konuşmaktan zevk alırım.	③	②	①
5	Odadan ayrılırken lambayı kapatmayı tercih ederim.	③	②	①
6	Buzdolabının kapağını uzun süre açık tutmam.	③	②	①
7	Geri dönüşümün ülke ekonomisine katkı sağladığına inanırım.	③	②	①
8	Çevremde bulunan bitkileri korumaya özen gösteririm.	③	②	①
9	Kullanılmış pilleri atık pil kutusuna atmaya tercih ederim.	③	②	①
10	Çevre konulu kitapları ilgi çekici bulurum.	③	②	①
11	Okulda çöpleri çöp kutusuna atmaya özen gösteririm.	③	②	①
12	Arkadaşlarımla birlikte sınıfımı temizlemekten keyif alırım.	③	②	①
13	Ağaçlara zarar vermenin doğal afetlere yol açabileceğini düşünürüm.	③	②	①
14	Çevremde bulunan hayvanları korumaya özen gösteririm.	③	②	①
15	Çevremde ağaçları görmek bana huzur verir.	③	②	①
16	Plastik poşet kullanmanın zararlı olduğunu düşünürüm.	③	②	①
17	Dişlerimi fırçalarken musluğu kapatmayı tercih ederim.	③	②	①