

A MICROCONTROLLER-BASED SIGNAL GENERATOR WITH HIGH OUTPUT CURRENT

Ersoy MEVSİM^{1*}, Reşat MUTLU²

¹Computer Technology Department, School of Vocational and Technical Sciences, Tekirdağ Namık Kemal University, Tekirdağ, Turkey

²Electronics and Communication Engineering Department, Çorlu Engineering Faculty, Tekirdağ Namık Kemal University, Tekirdağ, Turkey

Makale Künye Bilgisi: Mevsim, E., Mutlu, R. (2024). A Microcontroller-based Signal Generator with High Output Current, *Trakya Üniversitesi Mühendislik Bilimleri Dergisi*. 25(1), 1-9.

Article Info	Abstract
Article History: Received: December 13, 2023 Accepted: April 5, 2024	Signal generators play an important role in designing and testing circuits. These devices can supply various commonly used waveforms and can be designed using analog, digital, and Direct Digital Synthesis methods. Signal generators often have a low current output. In this paper, it is shown that a signal generator can be made using a cheap microcontroller board such as the Arduino Nano Klon V3.0 microcontroller. A power opamp TDA2030 is used to increase its output current. The signal generator can be operated up to 500 Hz Also, the signal generator can give an output current of up to 3 Amperes which is significantly higher than the ones sold in the market. The signal generator can be programmed to supply various common waveforms as well as any desired waveform considering its frequency limit.
Keywords: Microcontroller-based circuit design; Laboratory design; Signal generation; Direct Digital Synthesis.	

Yüksek Çıkış Akımına Sahip Mikrodenetleyici Tabanlı Sinyal Jeneratörü

Makale Bilgileri	Öz
Makale Tarihiçesi: Geliş: 13 Aralık 2023 Kabul: 5 Nisan 2024	Sinyal üreteçleri devrelerin tasarımında ve test edilmesinde önemli bir rol oynamaktadır. Bu cihazlar yaygın olarak kullanılan çeşitli dalga formlarını sağlayabilirler ve analog, sayısal ve doğrudan sayısal sentezleme yöntemleri ile tasarlanabilirler. Sinyal üreteçleri sıklıkla düşük akım çıkışına sahiptir. Bu makalede, Arduino Nano Klon V3.0 mikrodenetleyici gibi ucuz bir mikrodenetleyici kartı kullanılarak bir sinyal üreticinin yapılabileceği gösterilmiştir. Bu sinyal üreticinin çıkış akımını artırmak için bir güç opampı olan TDA2030 kullanılmıştır. Sinyal üretici 500 Hz'e kadar çalıştırılabilmektedir. Ayrıca, bu sinyal üretici, piyasada satılanlardan çok daha yüksek olan 3 Amper'e kadar çıkış akımı verebilmektedir. Sinyal üretici, frekans limiti göz önünde bulundurularak çeşitli yaygın dalga biçimlerinin yanı sıra istenen herhangi bir dalga şeklini sağlamak üzere programlanabilir.
Anahtar Kelimeler: Mikrodenetleyici tabanlı devre tasarımı; Laboratuvar tasarımı; Sinyal üretimi; Doğrudan Sayısal Sentezleme.	

1. Introduction

Signal generators are important devices, which should be found in all electronics laboratories (Abdullah, Muhammed, Al-Helali, 2008, Electronic Signal Generators, 2023). They can be designed using analog or digital circuits (Schubert and Kim 2016, Boylestad and Nashelsky 2018). Nowadays, the Direct Digital Synthesis (DDS) Method is also commonly used to design signal generators. A digital waveform generator is presented in (Shoucheng, Aimin, and Xinke 2012). A memristor-based chaotic signal generator is made in (Arık and Kılıç 2014). An FPGA is used to make a Van der Pol-based chaotic signal generator in (Dursun and Kaşifoğlu 2018). In (Ding, An, and Gou 2012), an FPGA is used to make a digital signal generator. FPGAs are more expensive than microcontrollers. In (Gontean, Lucaciu, and Dan 2003), an SDA6000 microcontroller-based TV signal generator that can provide TV test signals is made. In (Bilgin, Üser, and Oktay 2016), a microcontroller-based Programmable Signal Generator is made with an At89s52 microcontroller providing common signals and controlled by a keypad. In (Mandaliya, Mankodi, and Makwana 2013), a PIC microcontroller is used to obtain square, sinus, and triangle waves with the DDS method. In (Castro, Olmo, Pérez, and Yúfera 2016), a sinusoidal voltage wave generator, which is based on the use of microprocessor digital signals with programmable duty cycles with application to real-time Electrical Cell-substrate Impedance Spectroscopy (ECIS) samples, is proposed. In (Hu 2014), having SCM STC89C52 and MAX038 integrated circuits and with a few peripheral devices, a function signal generator, that generates sine, square, and triangular wave signals, has been designed with adjustable frequency and amplitude. Therein, the MAX038 function generator generates the desired waveform, which then is input into the LM6361 wideband voltage amplifier and a power amplifier as output. The DDS method is also used to design ECG, EEG, chaotic signal

generators, and neuron emulators successfully (Yener, Barbaros, Mutlu, and Karakulak 2017, Usta, Tepeyurt, and Karakulak 2021). Microcontroller-based chaotic signal generators can be done due to the microcontroller's computing abilities and sufficiently high clock frequency. In (Yener, Barbaros, Mutlu, and Karakulak 2017), a memristive chaotic circuit is implemented using Arduino. In (Yener and Mutlu 2018), an ECG signal generator is made using the PWM output of the ARM microcontroller and experimental data. An H-R neuron model is implemented with a microcontroller to obtain its waveforms in (Yener and Mutlu 2019). A chaotic waveform source that is based on Lorenz Equations is made to obtain Lorenz variables as the outputs with a microcontroller (Yener, Mutlu, and Karakulak 2020). A hyperjerk system is emulated with a microcontroller (Karthikeyan, Çiçek, Pham, Akgül, and Duraisamy 2020). The famous Lotka-Volterra Equations are examined with a microcontroller-based signal generator in (Karakulak, Tan, and Mutlu 2021). A microcontroller-based synthetic ECG waveform generator is made in (Usta, Tepeyurt, and Karakulak 2021). An EEG Signal Generator Using Both the internal DAC and PWM Outputs of a microcontroller is made in (Karakulak 2022). An oscillator's output current is usually not very high, just in the order of milliamps [1, 3]. High-power signal generators can be designed using power electronics (Mohan, Undeland, and Robbins 2003). Power electronics design may require more time and it is more complex due to the power component devices and drivers (Çınar and Arseven 2021). Intermediate load powers or currents can be supplied with a power amplifier if the load requires it (Boylestad and Nashelsky 2018). The voltage requirement of the device in the study given in (Karakulak and Mutlu 2020) has been supplied with a power amplifier due to a voltage requirement that cannot be provided by an ordinary opamp. Such an opamp can also provide a current of 4 Amps. In this

study, it has been shown that a microcontroller-based signal generator (MBSG) with high current output can be made using a cheap microcontroller such as Arduino Nano Klon V3.0 and a Digital Analog Converter, and a power opamp TDA2030. The TDA2030 provides a cheap solution for the high current need. It can supply a current of up to 3 Amperes which is a lot higher than currents in the order of milliamperes common opamps can deliver. Accordingly, due to the high current output, the designed signal generator can provide a high current that the traditional signal generators cannot.

In this study, first, the signal waveform equations are derived, and then, the system's hardware and software are briefly explained. The signal generator's operation is verified with experiments.

The paper is arranged as follows. In the second section, it is explained how the waveforms are produced in the MBSG. In the third section, the MBSG topology is introduced. In the fourth section, the flowchart of the MBSG program is explained. In the fifth section, the experimental results of the circuit are given. The paper is finished with the conclusion section.

2. Waveform Production

In this section, it is described how to produce the waveforms.

2.1. Waveform Formulas in Continuous Time

The desired waveform equations are given in this section. Such equations can be found in related books such as (Oppenheim and Verghese 2017). A sinusoidal voltage can be expressed as

$$v(t) = V_m \sin(\omega t) \quad (1)$$

where t is time, $\omega=2\pi/T$ is the angular frequency, T is the electrical period, and V_m is the maximum value of the sinusoidal voltage.

A triangular waveform can be given as

$$v(t) = \begin{cases} \frac{4V_m(t-T/2)}{T} + V_m, & 0 < t < T/2 \\ -\frac{4V_m(t-T/2)}{T} + V_m, & T/2 < t < T \end{cases} \quad (2)$$

where T is the electrical period and V_m is the maximum value of the triangular wave voltage.

A square waveform can be given as

$$v(t) = \begin{cases} V_p, & 0 < t < T/2 \\ -V_p, & T/2 < t < T \end{cases} \quad (3)$$

where T is the electrical period and V_p is the maximum value of the square wave voltage.

A Clock Pulse signal waveform can be given as

$$v(t) = \begin{cases} V_p, & 0 < t < T_p \\ 0, & T/2 < t < T \end{cases} \quad (4)$$

where T_p and V_p are the length and peak value of the Clock pulse voltage, respectively.

Using the duty ratio D , the length of the pulse is calculated as

$$T_p = DT \quad (5)$$

A sawtooth signal waveform with a rising slope can be given as

$$v[n] = \left\{ \frac{2V_p t}{T} - V_p, \quad 0 < t < T \right. \quad (6)$$

where V_p is the maximum value of the sawtooth voltage.

All the waveforms are periodic, i.e.

$$v(t) = v(t + T) \quad (7)$$

2.2. Waveform Formulas in Discrete Time

The signal waveforms are discretized in this section. A sinusoidal voltage in discrete time can be expressed as

$$v[n] = V_m \sin(n\omega T_s) \quad (8)$$

where $v[n]$ is the n th discrete time value of the signal voltage, n is sample time, ω is the angular frequency, and V_m is the maximum value of the sinusoidal voltage.

A triangular waveform can be given as

$$v[n] = \begin{cases} \frac{4V_m(nT_s - N/2)}{T} + V_m, & 0 \leq n \leq N/2 \\ -\frac{4V_m(nT_s - N/2)}{T} + V_m, & \frac{N}{2} + 1 \leq n \leq N \end{cases} \quad (9)$$

where $N = T/T_s$ is the electrical period in discrete time and V_m is the maximum value of the triangular wave voltage.

A square waveform can be given as

$$v[n] = \begin{cases} V_p, & 0 \leq n \leq N/2 \\ -V_p, & \frac{N}{2} + 1 \leq n \leq N \end{cases} \quad (10)$$

where T is the electrical period and V_p is the maximum value of the square wave voltage.

A Clock Pulse signal waveform can be given as

$$v[n] = \begin{cases} V_p & 0 \leq n \leq N_p \\ 0 & N_p + 1 \leq n \leq N \end{cases} \quad (11)$$

where N_p is the length of the pulse in discrete time.

A sawtooth signal waveform with a rising slope can be given as

$$v[n] = \{2V_p t/T - V_p, \quad 0 \leq n \leq N \quad (12)$$

where V_p is the maximum value of the sawtooth wave voltage.

In discrete time domain, the periodicity condition is given as.

$$v[n] = v[n + N] \quad (13)$$

Due to the periodicity condition, the value of the desired voltage is calculated at the discrete times for a period and using a loop and/or a lookup table, the voltage values in the following periods are calculated.

3. Microcontroller-Based Signal Generator

The Proteus schematic of the MBSG circuit is shown in Figure 1. It consists of the Arduino Nano Klon V3.0 microcontroller, and a DAC, and the power opamp TDA2030. The microcontroller executes the lookup tables obtained using the method given in the previous section. The microcontroller reads the desired

magnitude and frequency waveform, calculates the scaling factor, and sends the look-up table value through the digital ports to the DAC. At the output of the DAC, the desired waveform is obtained and amplified with the TDA2030. The signal at the output can be approximated as

$$v_{out}(t) = v[n][u(t - (n + 1)T_s) - u(t - nT_s)] \quad (14)$$

where $u[n]$ is the unit step function.

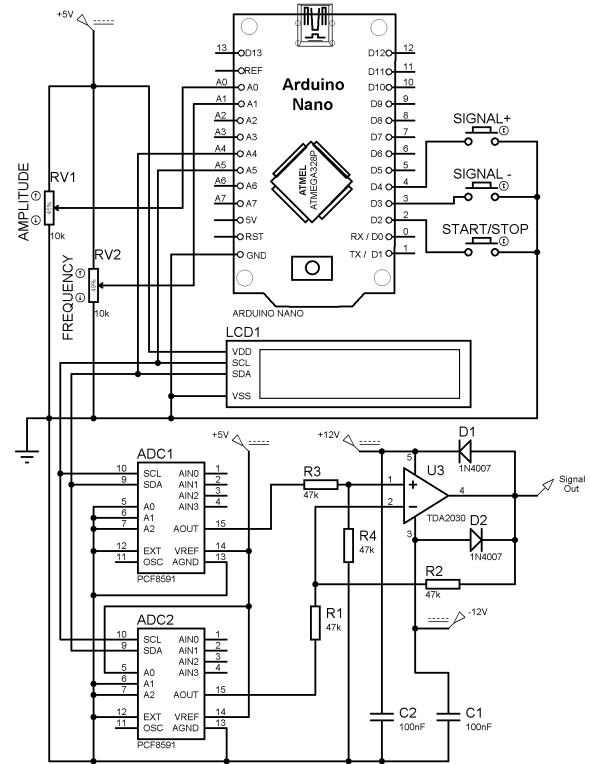

Figure 1. The circuit schematic was drawn in Proteus

4. The Circuit's Program

The microcontroller is programmed in C. The algorithm of the microcontroller program is given as the flowchart shown in Figure 2. The program takes the inputs such as which waveform is chosen. Then, the program starts calculating the discrete values of the desired waveform in a loop and keeps doing it until another waveform is chosen. When n equals N , n is reset to zero at the beginning of a new period. The

parameters required for the waveforms are adjusted by reading the ADC voltages.

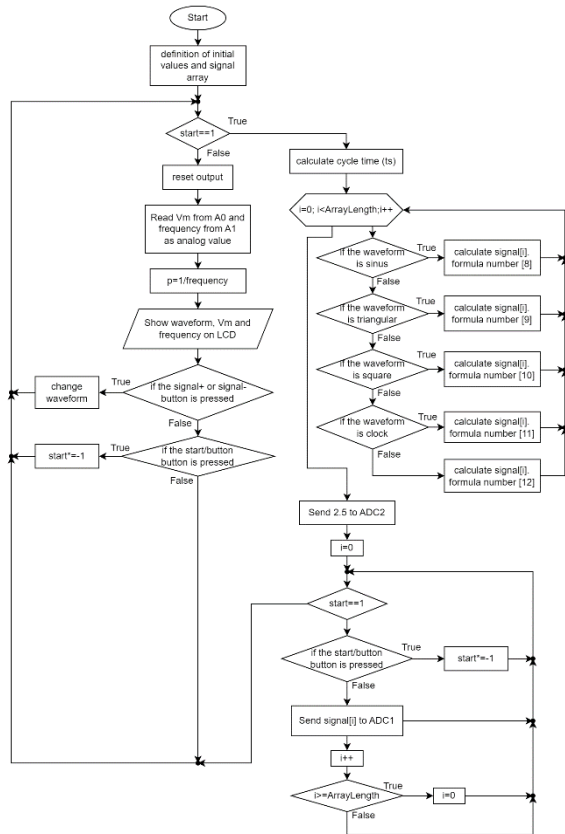
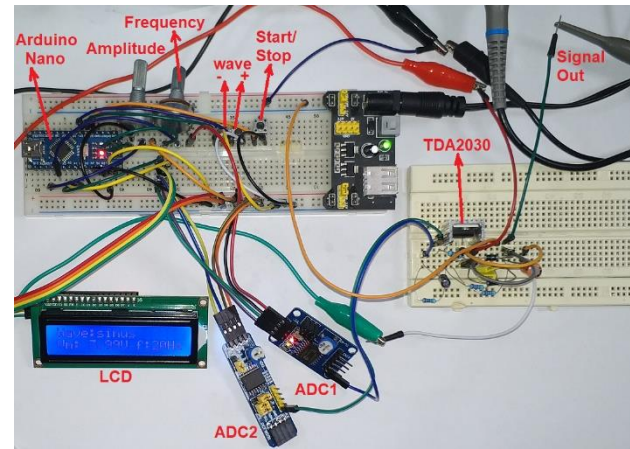

Figure 2. Flowchart of the VDPO Oscillator Program

5. Experimental Results of The Signal Generator

In this section, the experimental results of the MBSG circuit are given. The circuit whose photo is shown in Figure 3 has been assembled on a protoboard. The experimental voltage waveforms ($v_{out}(t)$) are acquired by a GW Instek GDS-1052-U 50 MHz digital oscilloscope. The experimental time domain waveforms are acquired in the periodic steady state and shown in Figures 4 and 5. The MBSG is able to produce all the waveforms up to 500 Hz and performs well. The effect of quantization on the waveforms can be seen in Figure 4. Increasing the DAC resolutions would result in decreasing the effect of quantization. At low frequencies of the output waveforms, the microcontroller can calculate more steps for the desired waveform in a period as can be seen in Figure 5. This

results in smoother waveforms at lower frequencies than the ones in Figure 4.



(a)

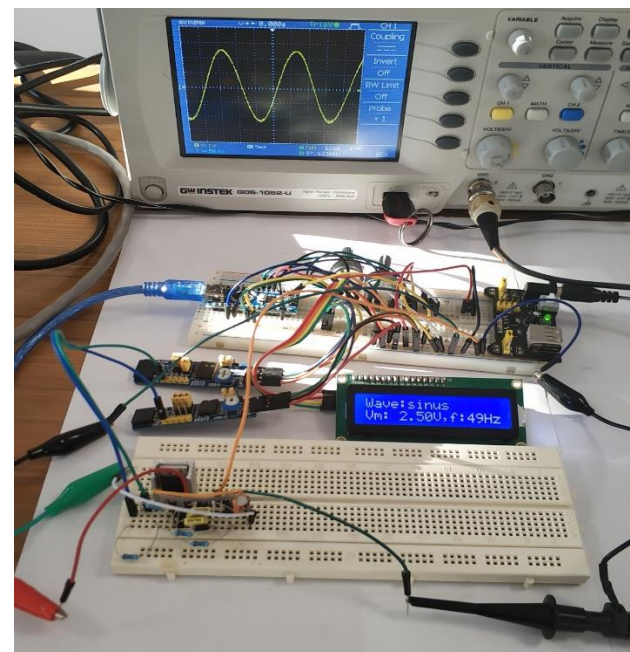

(b)

Figure 3. a) A photograph of the implemented circuit and b) The photograph taken during the measurement of a sinusoidal signal for $V_m=2.5$ Volt and $f=50$ Hz.

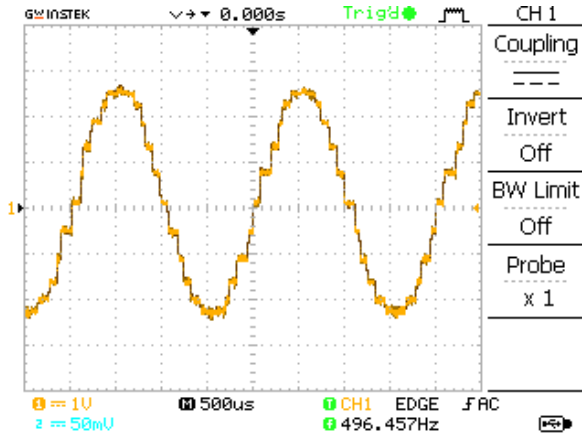

(a)

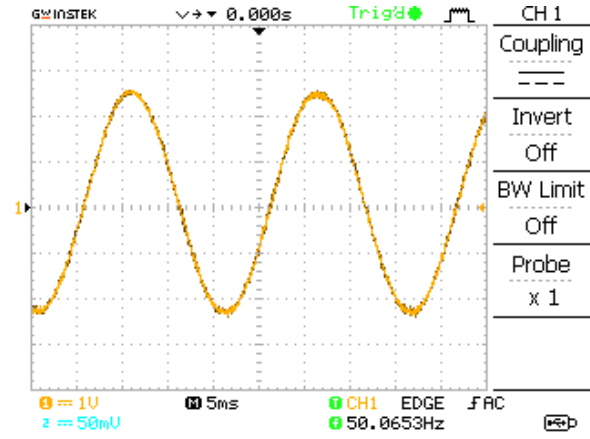

(a)

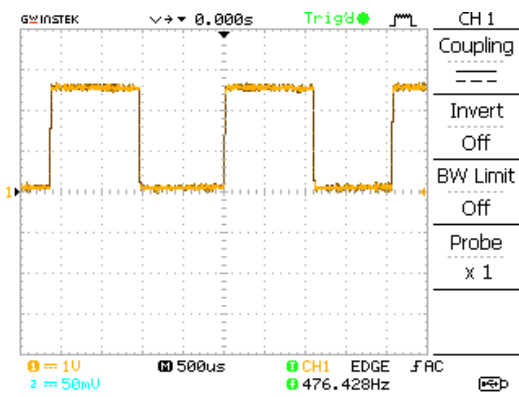

(b)

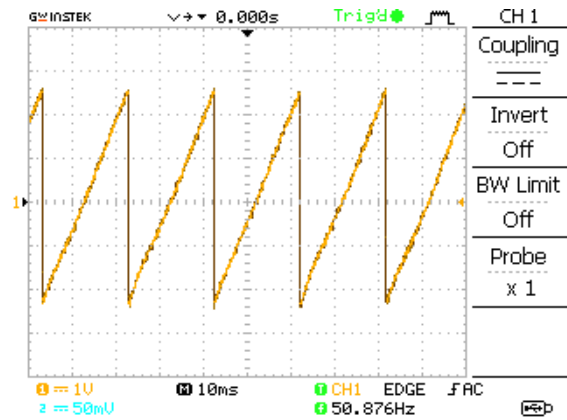

(b)

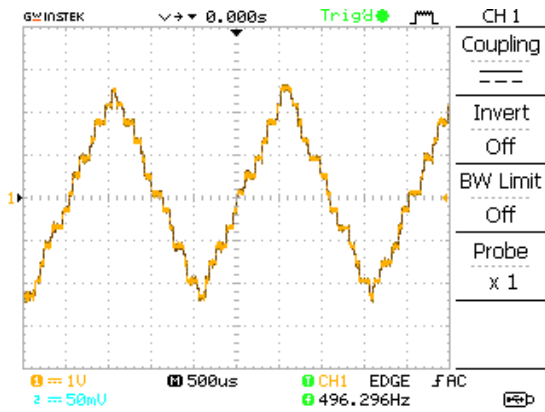

(c)

Figure 4. Experimental signal waveforms of microcontroller-based signal oscillator measured with an oscilloscope: a) a sinusoidal signal for $V_m=2.5$ Volt and $f=499$ Hz, b) a clock pulse signal for $V_p=2.5$ Volt and $f=470$ Hz, and c) a triangular waveform for $V_m=2.5$ Volt and $f=484$ Hz.

Figure 5. Experimental signal waveforms of microcontroller-based signal oscillator measured with an oscilloscope: a) a sinusoidal signal for $V_m=2.5$ Volt and $f=50$ Hz, and b) a sawtooth waveform for $V_p=2.5$ Volt and $f=51$ Hz.

5. Discussions

In the study, it has been seen that the resolution of the output voltage waveforms must be increased and this can be done using a DAC with a higher number of bits. The designed signal generator lacks an output filter and using a low-pass analog filter may help to reduce the resolution error and provide a low distorted output voltage waveform. The operation frequency of the designed signal generator was lower than that of the ones given in the introduction section. However, the output current of the designed signal generator is higher than that of the others reviewed in the introduction

section. The code of the designed signal generator can be optimized to increase its output frequency. If it is not enough, another microcontroller with a higher operation frequency can be used. Even in its current, the signal generator can be used for research and education purposes.

6. Conclusions

In this paper, a microcontroller-based high-current signal generator is designed. In this work, a cheap, rugged, easy-to-use microcontroller Arduino Nano Klön V3.0 microcontroller is preferred for this purpose. The device can supply a current of up to 3 Amperes because of having a power opamp while so many other signal generators can give a current less than 50 milliamperes. The signal generator has also its limitations defined by its electronic components. Its output current can be increased by using the power opamps in parallel if it is necessary. It can produce various waveforms. The experimental results have verified that the circuit performs well and produces waveforms with low distortion. Using a more advanced high-speed microcontroller such as ARM Microcontrollers, the signal generator that operates at higher frequencies can be made with a better

References

Arik, S., & Kilic, R. (2014). Reconfigurable hardware platform for experimental testing and verifying of memristor-based chaotic systems. *Journal of Circuits, Systems, and Computers*, 23(10), 1450145.

AL-Helali, R. A., Mohammed, I. A., & Abdullah, A. I. (2008). Microcontroller-based function generator. *Al-Khwarizmi Engineering Journal*, 4(1), 48-57.

Bilgin, S., Üser, Y., & Oktay, M. (2016). Low cost laboratory type signal generator using DDS method. *International Journal of Engineering and Applied Sciences*, 8(4), 59-65.

performance. Also, using a better DAC with a bit number of 16 or higher, the resolution error in its output waveform can be reduced.

The device can also be programmed with new waveforms or use experimentally recorded waveforms. For example, it can also be used to produce experimentally recorded EKG waveforms done as in (Yener and Mutlu 2018) or be programmed to obtain chaotic waveforms similar to those in (Yener, Barbaros, Mutlu and Karakulak 2017, Yener, Mutlu and Karakulak 2020). In the literature, there is an increasing number of chaotic communication circuits and the signal generator can be found in usage in them. Such a circuit can also be used evaluate performance of the circuits such as fractional order filters and controllers.

The designed MBSG, which is a cheap off-the shelf solution to have a signal generator, can be used in circuit laboratories such as electronics and biomedical engineering laboratories for research and educational purposes. Also, it can be used in graduate projects. As a future work, it can also be optimized using effective programming techniques considering the hardware's specifications.

Boylestad, R. L., & Nashelsky, L. (2018). *Electronic Devices and Circuit Theory* 11th ed.

Castro, J. A., Olmo, A., Pérez, P., & Yúfera, A. (2016). Microcontroller-based sinusoidal voltage generation for electrical bio-impedance spectroscopy applications.

Çınar, S. M., & Arseven, B. (2021). Kısmi Gölgeleme Etkilerini Modelleyebilen Bir PV Emülatör Tasarımı. *Journal of the Institute of Science and Technology*, 11(2), 982-997.

Ding, Shoucheng, An, Aimin and Gou Xinke (2012). "Digital Waveform Generator Based on FPGA",

- Research Journal of Applied Sciences, Engineering and Technology.
- Dursun, M., Kaşifoğlu, E. (2018). "Design and implementation of the FPGA-based chaotic van der pol oscillator", *International Advanced Researches and Engineering Journal*, 2(3), 309-314.
- Electronic Signal Generators, A Compilation, <https://ntrs.nasa.gov/api/citations/19720004434/downloads/19720004434.pdf>. (Access date: 01/12/2023).
- Gontean, A., Lucaciu, L., & Dan, B. (2003). Microcontroller Based Programmable Signal Generator. *IFAC Proceedings Volumes*, 36(1), 105-108.
- Hu, H. (2014). Design of a Functional Signal Generator based on MAX038 and Microcontroller. In *Advanced Materials Research* (Vol. 915, pp. 1167-1170). Trans Tech Publications Ltd.
- Karakulak, E., Tan, R. K., & Mutlu, R. (2021). STM32F429 Discovery Board-Based Emulator for Lotka-Volterra Equations. *Journal of the Institute of Science and Technology*, 11(3), 1887-1895.
- Karakulak, E (2022). ARM MCU-Based Experimental EEG Signal Generator Using Internal DAC and PWM Outputs. *Gazi University Journal of Science*, 1-1.
- Karakulak, E., & Mutlu, R. (2020). The memristive system behavior of a diac. *Journal of Computational Electronics*, 19(3), 1344-1355.
- Karhikeyan, R., Çiçek, S., Pham, V. T., Akgul, A., & Duraisamy, P. (2020). A class of unexcited hyperjerker systems with megastability and its analog and microcontroller-based embedded system design. *Physica Scripta*, 95(5), 055214.
- Mandaliya, H., Mankodi, P., & Makwana, B. (2013). Microcontroller based DDS function generator. *International Journal of Engineering Science and Innovative Technology (IJESIT)*, 2(1), 483-486.
- Mohan, N., Undeland, T. M., & Robbins, W. P. (2003). *Power electronics: converters, applications, and design*. John Wiley & sons.
- Rahma, Fadhil (2014). "Analog Programmable Electronic Circuit-based Chaotic Lorentz System." *Basrah Journal for Engineering Science* 14.1: 39-47.
- Schubert Jr, T. F., & Kim, E. M. (2016). *Fundamentals of electronics: Book 4 oscillators and advanced electronics topics*. Synthesis Lectures on Digital Circuits and Systems, 11(2), 1-266.
- Usta, B. N., Tepeyurt, B., & Karakulak, E. (2021). Simple Synthetic ECG Generation via PWM Output of Microcontroller. In *2021 5th International Symposium on Multidisciplinary Studies and Innovative Technologies (ISMSIT)* (pp. 27-30). IEEE.
- Yener, S. C., Barbaros, C., Mutlu, R., & Karakulak, E. (2017). Implementation of Microcontroller-Based Memristive Chaotic Circuit. *Acta Physica Polonica A*, 132(3), 1058-1061.
- Yener, Ş.Ç., and Mutlu, Reşat (2018). "A microcontroller-based ECG signal generator design utilizing microcontroller PWM output and experimental ECG data." *2018 Electric Electronics, Computer Science, Biomedical Engineerings' Meeting (EBBT)*. IEEE.
- Yener, Ş. Ç., & Mutlu, R. (2019). A Microcontroller Implementation Of Hindmarsh-Rose Neuron Model-Based Biological Central Pattern Generator. In *2019 1st International Informatics*

and Software Engineering Conference (UBMYK)
(pp. 1-4). IEEE.

Yener, Ş. Ç., Mutlu. R., & Karakulak. E. (2020).
Implementation of a Microcontroller-Based
Chaotic Circuit of Lorenz Equations. *Balkan
Journal of Electrical and Computer Engineering*,
8(4), 355-360.

Oppenheim, A. V., & Verghese, G. C. (2017). *Signals,
systems & inference*. London: Pearson.