



Optimization of Controller Parameter Multilevel Converter Based STATCOM for Reactive Power Compensation

Hamed Atyia Soodi¹, Yousif A. Hamad^{2,3,*}, and Ardam H. Mohammed¹

¹ Collage of Information Technology, Imam Ja'afar Al-Sadiq University, Baghdad, Iraq

² Collage of Computer Science and Information Technology, University of Kirkuk, Kirkuk, Iraq

³ Artificial Intelligence Laboratory, Siberian Federal University, Krasnoyarsk, 660074 Krasnoyarsk, Russia

* Corresponding Author: y.albayati@uokirkuk.edu.iq

Received: 18 december 2023; Accepted: 17 July 2024

Reference/Atf:

Abstract



Static Synchronous Compensator (STATCOM) is a self-tuning proportional-integral (PI) controller that has been developed to handle the voltage and reactive power of Cascaded H-Bridges (CHB-STATCOM) in order to improve the power system. The purpose of optimizing controller parameters for a Multilevel Converter-based STATCOM (Static Synchronous Compensator) in the context of reactive power compensation is to enhance the performance and efficiency of the STATCOM system in regulating the power factor and voltage of an electrical system. This controller was introduced in this article. This research presented that the STATCOM should have the capability to operate both in inductive and capacitive mode of operation and absorb or injects the desired amount of reactive power into the grid. The reactionary power that is received or supplied contributes to the improvement of the power system. The benefits of the self-tuning PI controller have been optimized to their full potential through the use of Accelerated Particle Swarm Optimization (APSO) strategies. The STATCOM is implemented into the electrical system, and its reaction to varying reactive and voltage levels is analyzed as part of the process of determining whether or not the optimization techniques are successful. Two controllers are now in operation at the STATCOM. The first controller is in charge of managing the DC voltage, and the second controller is in charge of controlling the reactive power. Both controllers are in use at the same time. The output of the controller is then transferred to the phase change carrier, which is followed by pulse width modulation in a sinusoidal pattern. Because of this, the power converter switch may now function properly.

Keywords: APSO, Reactive power compensation, STATCOM, PI control, Phase shift pulse width modulation, APSO

1. Introduction

Brought on by non-linear loads have a deleterious effect on both power quality and grid dependability over time. Because total system power is determined by adding together the system's active and reactive powers, an increase in reactive power is inextricably related to a similar increase in total power. In [1, 2], several strategies for increasing the grid's response power are described. Because of how successfully they control the overall system's reactive power, shunt Flexible AC Transmission System (FACTS) devices are widely used. A coordinated power source consisting completely of solid-state components is used to power STATCOM and other FACTS systems. Connected in series with the power supply, it is an excellent replacement for the cumbersome reactive components of conventional static VAR compensators (SVC). It also beats SVC in terms of the dependability of the nation's electrical grid. [3]. STATCOM's primary role is to control voltage at the point of common coupling (PCC) during a power system changeover. The STATCOM obtains these reactive currents from the power infrastructure in a controlled fashion. Intricate design challenges for these layered STATCOM [4] stem from the need for a large number of instruments to track DC voltage and uneven voltage across the DC-link capacitor [5] A conventional two-loop management system was proposed. The PCC voltage is controlled by the outer loop, and the inverter current is controlled by the interior loop with a steady-state inaccuracy of zero. Capacitor banks were among the first components of electrical apparatus to be installed in an effort to regulate power supply. However, with the help of modern technology, system managers have access to

more flexible and effective tools that can manage huge quantities of power. Flexible AC transmission systems are a specific type of these tools. (FACTS). These devices are carefully installed on selected electric buses, and they are used to quickly alter various system settings in order to boost system efficiency, control power flow, and enhance system reliability [6]. They are large-scale regulators that modify system-wide parameters like reactive power, voltage, and phase angle. [1].

Numerous researches have determined PI benefits through trial and error to reach an optimal working point, power system under STATCOM control exhibits significantly non-linear behavior. Linear controllers are simple to implement but difficult to fine-tune in this architecture. Transient performance requirements must be addressed by fine tweaking of controller settings. In this research, we use the non-linear and non-gradient Simplex algorithm to optimize the control system parameters of a STATCOM built from two converters based on six-pulse voltage sources. The performance index serves as the basis for the objective function of the system, which is written in terms of the actual and ideal values of the system's variables. Several simulation tests examining step-response performance have validated the optimized performance of the STATCOM control system, which consists of two PI controllers and two compensators. With the right settings in place, the system responds quickly and precisely [2–7]. This is not a good option in practice due to the radical changes in system features brought about by the inclusion of STATCOM devices or the improvement of the transmission architecture. [8].

In the realm of heuristics for parameter optimization, accelerated particle swarm optimization (APSO) [9] is a well-known method. It has been used to modify controller gains [10-11]. It is possible for the gains of an APSO-based PI scheduler to auto-tune in response to variations in the system and demand. This will result in a significantly more adaptable PI system. The consensus time of APSO is low (A Moreover, it outperforms SVC in terms of power system reliability [3]) because it does not necessitate offline training like an artificial neural network. During a transition in the electricity system, STATCOM's main function is to regulate the voltage at the point of common coupling (PCC). The most important development challenges for these layered STATCOM [7] involve extracting controlled reactive currents from the electrical infrastructure. are the many instruments used to track DC voltage and imbalanced voltage at the DC link capacitor. It also ignores the reasoning principles of the approximate control, which points to PSO's superior performance [12] -[25].

Optimizing the controller parameters for a Multilevel Converter-Based Static Synchronous Compensator for reactive power compensation can be a challenging task, and there are several potential problems and issues that may arise during the optimization process, Multilevel converters are inherently complex due to the multiple voltage levels they can generate. Optimizing the controller parameters for such converters requires a deep understanding of their operation and the interaction between different voltage levels. There may be trade-offs between different control objectives, such as voltage regulation, harmonic mitigation, and response time. Finding the right balance among these objectives can be challenging. Power systems are subject to variability due to changes in load, generation, and network conditions. The optimized parameters that work well under one set of conditions may not perform optimally under different conditions. The accuracy of the system model used for optimization is crucial. Inaccurate models can lead to suboptimal parameter values or instability in the real system. Over-optimization, where parameters are tuned too precisely for specific operating conditions, can lead to instability or poor performance when conditions deviate from the optimized scenario. Changes to controller parameters can impact the safety and reliability of the power system. Safety measures and risk assessments must be considered during the optimization process.

A Multilevel Converter-Based STATCOM presents various technical and practical challenges. It requires a combination of expertise in control theory, power systems, and optimization techniques, along with careful consideration of system complexity and constraints. Successful optimization should aim to strike a balance between different control objectives while accounting for the dynamic and variable nature of power systems.

In this investigation, we use Accelerated Particle Swarm Optimization to design a self-tuning PI controller for CHB-STATCOM [13]. (APSO). By tweaking the original PSO algorithm, we get accelerated PSO. The primary goal of this research is to develop a robust CHB-STATCOM scheduler that can effectively account for disturbances within a few cycle time windows of their occurrence.

2. STATCOM

To sum up, STATCOM is an apparatus that counteracts the reactive power of an electrical grid. It may behave as both a generator and a sink of reactive energy. To complement the tiny synchronous condenser compensator (STATCOM) that controls the PCC's power factor (PF), the proposed inverter does double duty by transforming DC power from the DC link into AC power for the mains supply and syphoning off enough reactive power from the grid to increase the PCC's PF [14]. The major power line and the primary power line servicing the PCC are both illustrated in Figure1 as part of the basic STATCOM arrangement. Transformer, capacitor, coupling reactor, and regulated power supply make up the voltage source converter (VSC) in the centre of a STATCOM.

In addition to its more common name, "voltage source converter," or "VSC," can also refer to a device that converts direct current (DC) to alternating current (AC). It can produce asymmetrical AC power with user-defined phase and angle of rotation. A VSC can be charged while the DC battery stores energy. By using coupling reactance to link the sources to the system and regulate the current, the converter output can be joined to the power system. The coupling transformer regulates the input voltage of the STATCOM converter and the output voltage of the PCC.

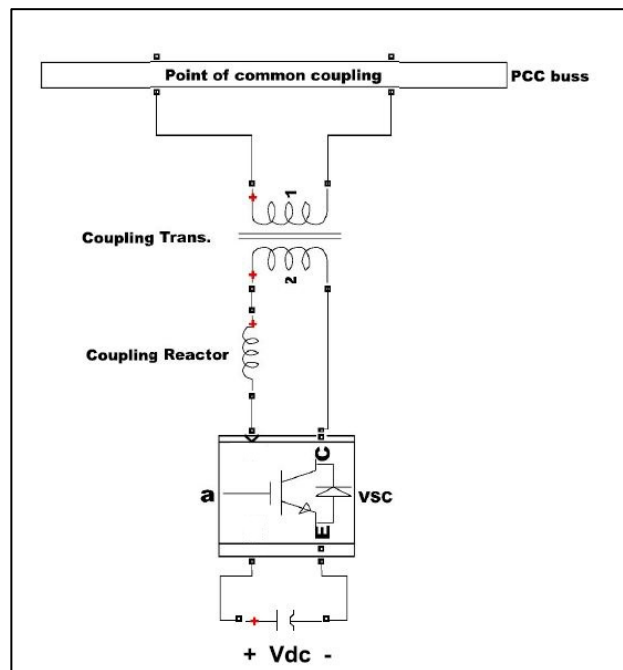

Figure 1: The grid connection of STATCOM

System software A STATCOM can be used either in VAR mode or with voltage control turned on. The STATCOM aids the PCC in keeping the voltage stable during dynamic disruptions, allowing the PCC to provide superior transient properties. By switching into this state, a STATCOM will either:

- When the system voltage is high, the STATCOM will absorb reactive power.
- When the system voltage is low, the STATCOM will generate and inject reactive power.

The STATCOM reactive power production is either held steady or adjusted based on VAR mode monitoring of the reactive power and comparison to a standard number.

Multi-level simulation of a single-phase cascaded H-bridge converter. Multilayer cascaded H-bridge inverters have a basic layout shown in Figure2. This N-level converter offers the possibility of $2N+1$ different values for the phase voltage at the output. Because of the power requirements of each H-bridge, the previously noted voltage discrepancy problem may be avoided. However, to prevent voltage fluctuations of the DC-bus capacitor, it is necessary to adjust the active power provided to each bridge. [4]. There are a number of methods outlined in [5] for dampening DC-link voltage variations.

Many applications also take reactive power into account, which is where the cascaded H-bridge architecture shines. Since high-power electrical switches have their limits, we have to settle with a low-frequency modulation strategy. [6]- [8]. When compared to a regular power supply, a multilevel converter offers several advantages. Since the output pattern has fewer spurious harmonics, cheaper, smaller output filters may be employed. Since there are more voltage steps between the highest and lowest values in the staircase pattern, the voltage burden on semiconductor components is lessened. Switching losses may be minimized in multi-level inverters due to their lower switching frequency [1]. Multiple converters often use SPWM as the primary management technique. By contrasting a triangle waveform with a sine wave, PSPWM generates control signals for converter switches.

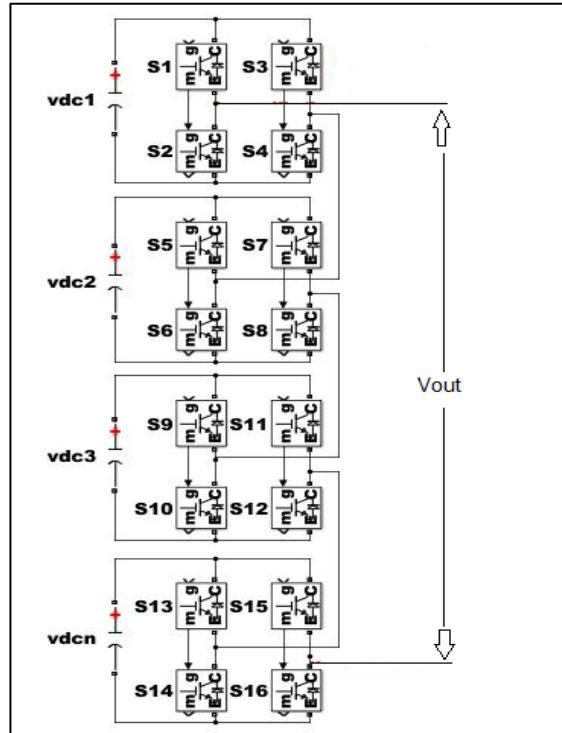

Figure 2: Model of power-stage CHB multilevel converter

3. Overview Of Accelerated Particle Swarm Optimization (APSO)

The optimization method known as particle swarm optimization [14–18] is inspired by natural swarms like those of fish and birds. The PSO algorithm gets the best answer by first producing a random sample of candidates, or particles, and then offering incentives to the candidates still in the running, or particles. Particles may be created via either collaborative or adversarial interactions. The equation allows for a point in D-dimensional space to represent any given particle I. $X_i = (xi1, xi2, \dots, xiD)$.

The optimal answers in the full collection fall into two distinct categories: P_{best} , or cognitive learning, is the particle's best response across rounds and is defined as $P_{best} = (pi1, pi2, \dots, piD)$, while G_{best} , or the swarm's best solution, is defined as the solution with the highest fitness. (Called social learning). Every repetition k brings the particle located at $x(k)$ one step closer to the P_{best} and G_{best} , and this motion is indicated by its velocity (written $v(k)$). The speed is determined by combining the knowledge of both individual particles and the collective swarm, and can be written in D-dimensional space as $V_i = (vi1, vi2, \dots, viD)$. Each particle then uses the following calculation to make an approximation of its motion for the next cycle:

$$v_i(k+1) = w_i v_i(k) + c_1 \cdot rand. (P_{best} - x_i(k)) + c_2 \cdot rand. (G_{best} - x_i(k)) \quad (1)$$

With the help of the gravitational constant (w), the cognitive constant ($c1$), and the societal constant ($c2$), the $rand()$ algorithm generates a random integer between 0 and 1. The rate of convergence is

affected by all these factors. Clerc's optimal numbers were $c_1=1.494$, $c_2=1.494$, and $w=0.729$ [22-25]. PSO's cost function must be adjusted to reflect the intended system behavior under these conditions. The PSO keeps running its procedures for the given amount of time to find the best answer. The next iteration's particle position is calculated using the following algorithm. 'k+1':

$$X_i(k+1) = v_i(k+1) + X_i(k) \quad (2)$$

After making some educated guesses, we can figure out what size community to use to initiate PSO. In spite of the fact that the optimum population is context-dependent, the PSO developers have stated that starting with a population of 20-100 particles typically yields the same outcomes [16], [26]. The Quick Optimization of Particle Swarms (APSO) While standard PSO takes into account both global and local best particle sites when determining particle motion for the next cycle, accelerated PSO only takes into account global best particle locations [17]. In PSO, utilizing local best serves to increase the size of the search area; in APSO, sampling is used to achieve the same effect. Unless the problem is very complex, this quantity causes the strategy to "accelerate" towards optimality [26]. The simplified new algorithm is as follows:

$$v_i(k+1) = w_i v_i(k) + c_1 \cdot rand + c_2 \cdot rand \cdot (G_{best} - x_i(k)) \quad (3)$$

4. Implementation Strategy

4.1 Design Objectives

The STATCOM employed in this study has two major purposes:

- To give reactive power to the system when it is operating in capacitive mode and
- To remove reactive power while it is running in inductive mode.

4.2 System Design

STATCOM used in this study consists of nine-level with four similar CHB connected in series, each with its own power supply. (DC Capacitor). Each H-bridge can produce a positive, neutral, or negative voltage at its output. When these energies are added together, a sine pulse is produced. The phase magnitude of an AC output is represented as follows [18-22]:

$$V_{ca} = V_{ca1} + V_{ca2} + V_{ca3} + \dots + V_{caM} \quad (4)$$

M denotes the number of inverters per phase. The flexible design of a cascading multilevel inverter (CMI) makes adding more similar H-bridge inverters to the circuit a straightforward way to boost output. Energy from the connection inductance is corrected and supplied through the H-bridge to the DC capacitors attached to the other side of the bridge. Capacitance can be calculated as follows:

$$C = \frac{i_c}{f_{rp} \cdot \Delta V_{DC}} \quad (5)$$

f_{rp} : frequency of ripples

i_c : maximum rms current

$$i_c = \frac{Q}{V_{pcc}} \quad (6)$$

Q : the maximum reactive power can be generate or absorb by STATCOM . As a reactive power coupling between the PCC and the STATCOM, the inductor's capacitance is affected by the current harmonics and the CMI. To calculate inductance, use the following formula:

$$L_{fmax} = \frac{v_{PCC}}{2 * \pi * f * I_c} \quad (7)$$

F: System fundamental frequency

v_{PCC} : Voltage at PCC

The above solution gives the highest allowable inductance capacity. Due to its massive scale, this inductor effectively dampens current waves and overtones at the PCC Transformer. Due to the need to limit the residual of voltage power networks, the STATCOM cannot be hardwired to the grid. In order to bring the power down to a level that the equipment can manage, a converter is required. However, there may be power deficits associated with using a converter, such as increased compensatory currents on the STATCOM side. Procedure for controlling depending on the PI controller.

The proposed control approach involves the use of PI controllers, one to determine the phase angle from the DC voltage and another to determine the modulation index from the difference between the targeted and measured reactive power. The modulator receives inputs such as the toggling components' on/off states, the current, and the voltages across the capacitors. As shown in Figure3, the control architecture's primary block layout is laid out in logical fashion.

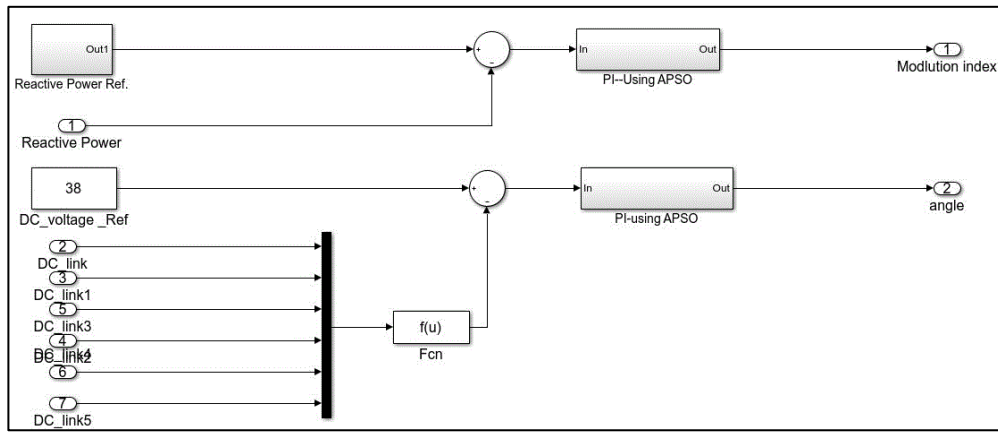

Figure 3: Schematic of proposed control strategy using PI controller

The reactive power that the STATCOM supplies to the line is given by the equation below:

$$Q_s = \frac{E_c^2 - E_c E_s \cos \delta}{X} \quad (8)$$

Where:

x : the coupling reactance

E_s : RMS value of PCC Voltage

E_c : STATCOM output voltage

The STATCOM's can adjust the reaction strength by adjusting the frequency it operates at. The following is a broad description of the connection between the DC link voltage and the STATCOM output voltage.

$$\frac{V_{out}}{E_{DC}} = m \quad (9)$$

Therefore, the reactive power equation changes to

$$Q_s = \frac{E_s^2 - m E_{DC} E_L \cos \delta}{X} \quad (10)$$

The solution above illustrates how the STATCOM operates. In the suggested setup, the modulation index regulates the reaction strength of the STATCOM. The primary regulator of the STATCOM. The phase locked loop (PLL) component provides not only the phase but also the phase angle (ωt) of a voltage signal for verification purposes.

5. Simulation And Results

The whole form of the modeling software’s depiction of the system is shown in Figure 4.

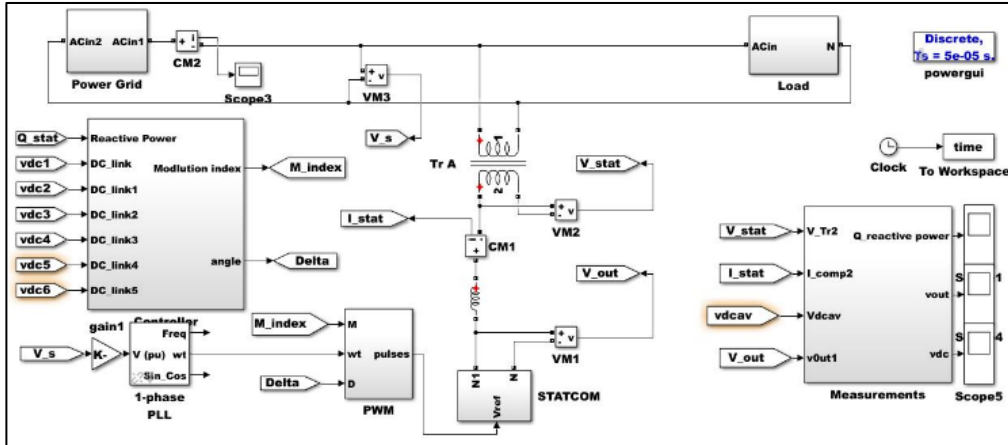

Figure 4: Simulink block diagram of complete system

To cope with a nonlinear load, the H-bridge circuit in Figure5 uses a perfect IGBT and a reactive power reference. The scenario is executed without STATCOM, with a power factor of 0.7 for all loads, and with inductive/capacitive load powers varying from 0 to 14 seconds and capacitive load powers ranging from 14 to 28 seconds. Table 1 contains the model's characteristics.

Table 1: System parameters

Type	Parameter	Value
Source	PCC Voltage (L- L)	311.12 V
	System Frequency (Hz)	50 Hz
Load	Voltage (V)	220Vrms
	Real Power (Watts)	450 W
	Reactive Power Inductive	450 VAR
	Reactive Power Capacitive	450 VAR
Dc Link volt	DC Link reference Voltage (Volts)	27 V
Coupling Transformer	Nominal Power (VA)	5000 VA
		220/110 V

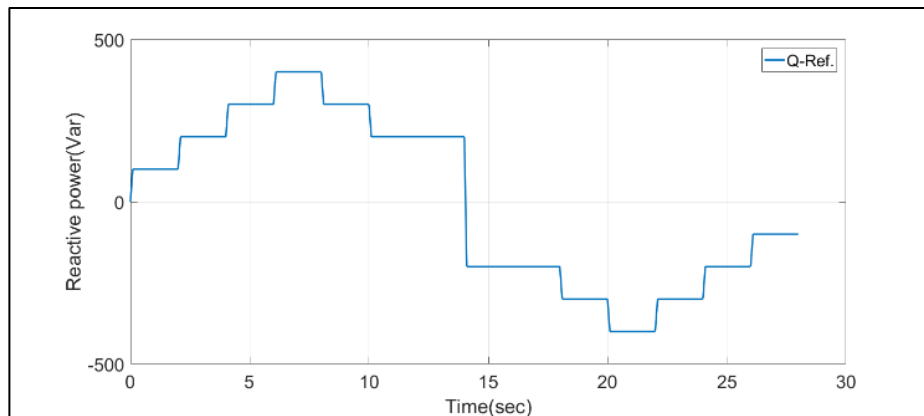

Figure 5: Reactive power reference signal for STATCOM

The PI-based APSO management method is advocated by the computer program. Figure6 displays the layered inverter's output voltage's thirteen discrete steps. The reactionary power of the STATCOM is depicted in Figure7, and the APSO technology is what gives the PI control its durability and versatility.

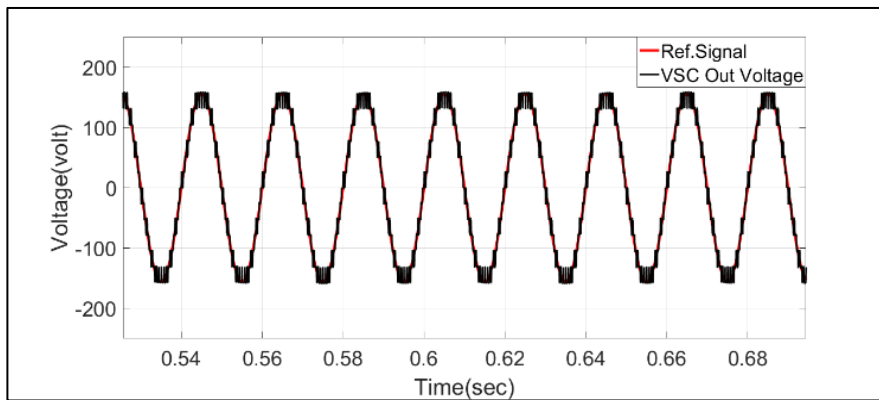

Figure 6: STATCOM-output voltage and reference signal

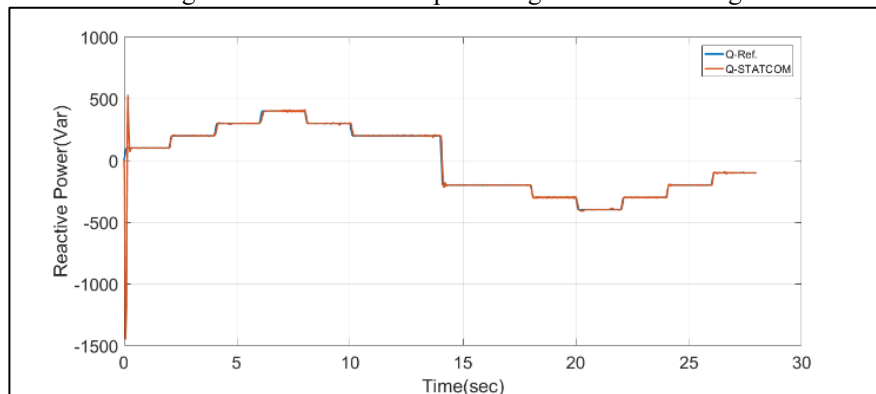

Figure 7: STATCOM- reactive power with APSO

The effectiveness of the APSO method can be further examined by plotting the cost functions for both controllers in addition to the PI controller gains k_p and k_I . Figure8 displays the gains achieved by the reactive power converter over the course of 50 trials. The advantage in k_I increases to 6.1, then drops to the optimal number of 0.1. The k_p trajectory, on the other hand, shows a negligible decrease from its initial 0.6 to its ultimate 0.01035.

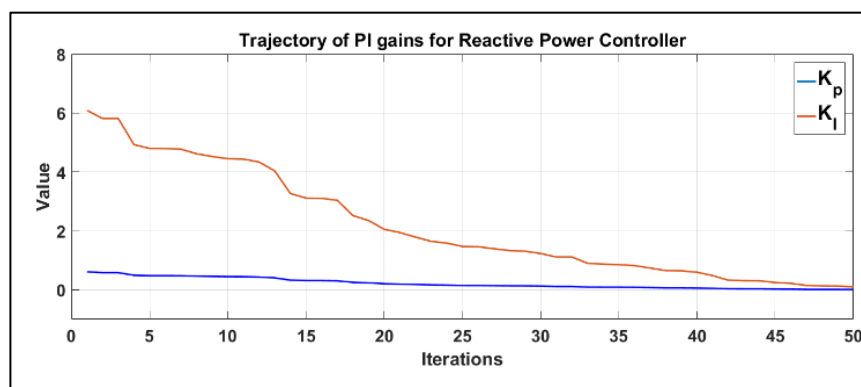

Figure 8: PI parameters for reactive power controller iterations using APSO

The Figure9 depicts the reduction in IAE (cost function) caused by a reactive power converter. After running through APSO's rounds, the cost naturally drops from a high of 1.1 to a low of 0.17, which is an acceptable margin of error.

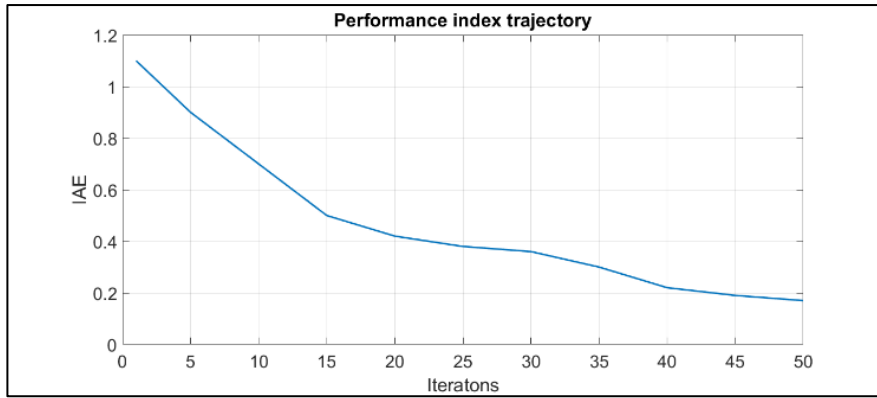

Figure 9: IAE for reactive power controller iterations using APSO

Another controller that provides comparable trajectory options is the APSO-optimized DC-Link PI controller. The Figure10 can be seen, the K_p gain number begins at 11.8 and increases gradually to 3.1. The rise has been larger in recent versions than in previous ones. In a similar vein, the K_i gain, which was originally fixed at 013.9, steadily declines to 0.355 after 50 cycles. Figure11 shows the iterative readings of the IAE. The APSO method fails after 50 rounds, with an initial error of 0.67 and a final error of 0.091.

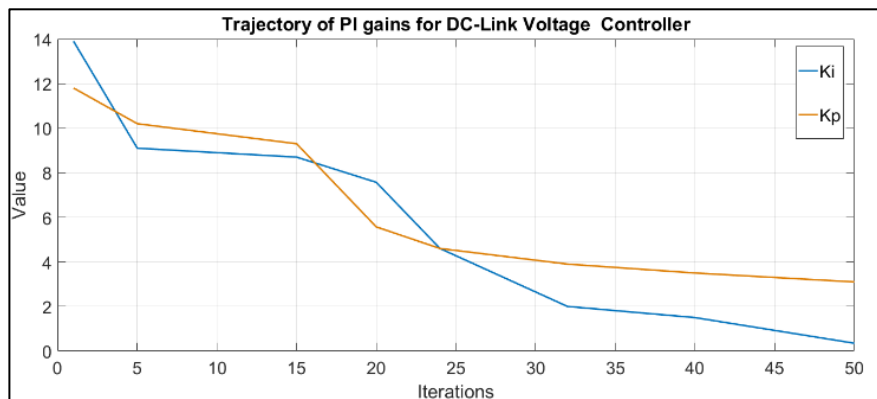

Figure 10: PI parameters for DC-Link Voltage controller with iterations using APSO

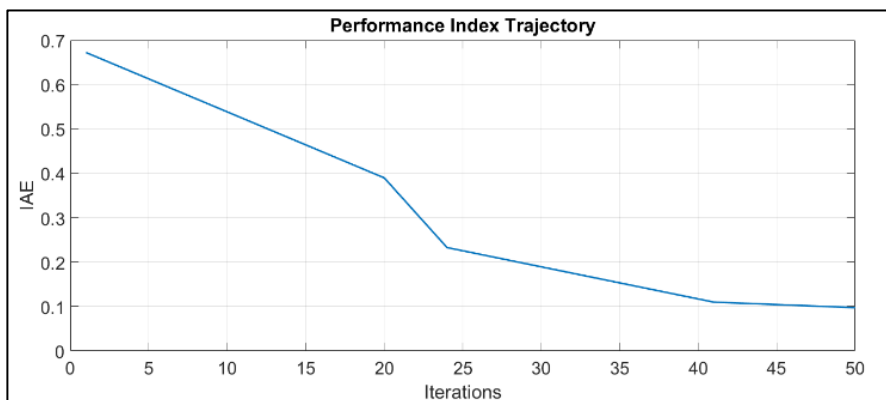

Figure 11: Trajectory of IAE for DC-Link Voltage controller with iterations using APSO

Optimizing the controller parameters of a Multilevel Converter-Based Static Synchronous Compensator for reactive power compensation can offer several advantages in power systems. STATCOMs are a type of Flexible AC Transmission System (FACTS) device used to control and stabilize the voltage and reactive power in electrical grids. Optimization of controller parameters allows for precise control of the STATCOM's output voltage. This helps in maintaining grid voltage within specified limits, reducing

voltage fluctuations, and ensuring a stable and reliable power supply. By optimizing controller parameters, the STATCOM can provide efficient reactive power compensation. This helps in minimizing voltage drops, improving power factor, and reducing line losses. Properly tuned controller parameters enable the STATCOM to respond quickly to changes in the grid's reactive power requirements. This rapid response time ensures that voltage and power factor are kept within desired limits, even during transient events. Multilevel converters used in STATCOMs can generate harmonics if not controlled properly. Parameter optimization can mitigate harmonics, ensuring a cleaner and more stable power supply with minimal distortion. A well-tuned STATCOM contributes to grid stability by damping out oscillations, reducing voltage flicker, and preventing voltage sags and swells. This, in turn, enhances the overall reliability of the power system. Optimizing the controller parameters can lead to more efficient operation of the STATCOM. This means that the device consumes less reactive power from the grid, reducing energy losses and improving the overall energy efficiency of the system. Improved voltage regulation and reduced losses result in cost savings for utilities and end-users. With optimized STATCOM control, there is less need for additional equipment to maintain grid quality. STATCOMs are increasingly used in conjunction with renewable energy sources like wind and solar power. Proper parameter optimization ensures seamless integration and improved grid stability in renewable energy systems. Optimization allows for the development of control strategies tailored to specific grid conditions and requirements. This adaptability is crucial in addressing varying grid challenges. Many countries have stringent grid codes that require power quality standards to be met. Optimized STATCOM controllers can help meet these regulatory requirements, avoiding penalties and ensuring compliance.

6. Conclusion

The Adaptive Particle Swarm Optimization (APSO) algorithm is a powerful optimization approach rooted in the principles of swarm intelligence, drawing inspiration from the collective behaviors of natural swarms like fish or birds [14]. Voltage optimization plays a pivotal role in maintaining the operational efficiency and reliability of electrical distribution systems by ensuring voltage levels remain within acceptable parameters. Leveraging the STATCOM (Static Synchronous Compensator) in conjunction with APSO offers a viable strategy for achieving this optimization goal. A STATCOM, as a component of Flexible AC Transmission Systems (FACTS), possesses the capability to control reactive power flow within the electrical grid. This device, consisting of a voltage source converter (VSC) driven by power electronics, can dynamically generate or absorb reactive power as required, providing essential voltage support to the system. APSO, an evolution of the Particle Swarm Optimization (PSO) algorithm, harnesses the innate behaviors of swarming creatures to fine-tune the settings of STATCOM and effectively regulate the system's voltage in the context of voltage optimization. PSO, a metaheuristic optimization technique, orchestrates a population of potential solutions, referred to as particles, in a dynamic and purposeful manner, much like the cooperative or competitive interactions observed in natural swarms. Each particle, representing a point in a multidimensional space, is guided towards the optimal solution through iterative adjustments, ultimately yielding the best configuration for achieving voltage optimization. The successful optimization of controller parameters not only enhances the STATCOM's ability to provide reactive power compensation but also contributes to the overall stability and reliability of the power system. It allows for better control of voltage levels and mitigation of power quality issues such as voltage sags and swells, thereby improving the quality and efficiency of electricity distribution.

Additionally, the optimization of controller parameters for Multilevel Converter-based STATCOMs represents a critical step towards achieving optimal reactive power compensation and improving the overall performance of power systems. This ongoing research and development effort continue to play a vital role in ensuring a stable, reliable, and high-quality supply of electricity to meet the demands of modern society.

Contribution of Researchers

Conceptualization, Y.A.H. and H.A.S.; methodology, Y.A.H., H.A.S. and M.H.A.; software, H.A.S and A.H.M, validation, M.H.A., A.H.M; formal analysis, A.H.M and H.A.S.; investigation, Y.A.H. and M.H.A.; data curation, Y.A.H. and H.A.S.; writing—original draft preparation, A.H.M, Y.A.H. and A.H.M, writing—review and editing, A.R., Y.A.H. and M.H.A.; visualization, A.H.M. All authors have read and agreed to the published version of the manuscript.

Conflicts of Interest

The authors prove that the article without any conflicts of interest.

References

- [1]. J. Rodriguez, J. S. Lai and F. Z. Peng, "Multilevel inverters: survey of topologies, controls, and applications," IEEE Trans. on Industry Applications, Vol. 49, No. 4, pp. 724-738, 2002 .
- [2]. S. Panda and N. P. Padhy, "location and controller design of STATCOM for power system stability improvement using PSO," Journal of the Franklin Institute, (2007).
- [3]. Saman Babaei "A Control Structure for Line- Frequency-Switched STATCOMs under System Faults", Department of Electrical and Computer Engineering, 978-1-4799-0336-8/13 IEEE, Sept 2013
- [4]. Verma Amitkumar, Kamani PL, Kapadia RR. A review on gridpower quality improvement in wind energy system using STATCOM with BESS. J Emerg Technol Innov Res (JETIR);2(1):26e31,(2015).
- [5]. Neyshabouri, Y., Iman-Eini, H., Miranbeigi, M.: 'State feedback control strategy and voltage balancing scheme for a transformer-less STATic synchronous. COMPensator based on cascaded H-bridge converter', IET Power Electron., 8, (6), pp. 906–917, 2015.
- [6]. Zotin, A., Hamad, Y., Simonov, K., Kurako, M., & Kents, A. (2020, June). Processing of CT lung images as a part of radiomics. In International Conference on Intelligent Decision Technologies (pp. 243-252). Singapore: Springer Singapore.
- [7]. Hamad, Y., Mohammed, O. K. J., & Simonov, K. (2019, March). Evaluating of tissue germination and growth rate of ROI on implants of electron scanning microscopy images. In Proceedings of the 9th international conference on information systems and technologies (pp. 1-7).
- [8]. C. Tareila, P. Sotoodeh, R. D. Miller., "Design and control of a singlephase D-STATCOM inverter for wind application", Power Electronics and Machines in Wind Application PEMWA 2012, Denver, Co, 2012.
- [9]. Sun, Y., Zhao, J., Ji, Z., et al.: 'An improved DC capacitor voltage balancing strategy for PWM cascaded H-bridge converter-based STATCOM'. Proc. IEEE 10th Int. Conf. Power Electronics Drive Syst., Kitakyushu, Japan ,pp. 1245–1250, April 2013.
- [10]. Vural, A. M. (2016). Self-capacitor voltage balancing method for optimally hybrid modulated cascaded H-bridge D-STATCOM. IET Power Electronics, 9(14), 2731-2740.
- [11]. Taha, O.A., Pacas, M.: 'Hardware implementation of balance control for three-phase grid connection 5-level cascaded H-Bridge converter using DSP'.Proc. IEEE 23rd Int. Symp. Industrial Electronics, Istanbul, Turkey ,pp. 1366–1371, June 2014.
- [12]. Sotoodeh, Pedram, and Ruth Douglas Miller. "A single-phase 5-level inverter with FACTS capability using modular multi-level converter (MMC) topology." Electric Machines & Drives Conference (IEMDC), 2013 IEEE International. IEEE, 2013.
- [13]. Neyshabouri, Y., Iman-Eini, H., Miranbeigi, M.: 'State feedback control strategy and voltage balancing scheme for a transformer-less STATic synchronous. COMPensator based on cascaded H-bridge converter', IET Power Electron., 8, (6), pp. 906–917, 2015.
- [14]. Behrouzian, Ehsan, Massimo Bongiorno, and Remus Teodorescu. "Impact of switching harmonics on capacitor cells balancing in phase-shifted PWM-based cascaded H-bridge STATCOM." IEEE Transactions on Power Electronics 32.1 (2017): 815-824.
- [15]. S. U. Shinde, M. Sharmila, R. S. Patil and D. V. Malkhede, "Performance comparison of PI & ANN based STATCOM for 132 KV transmission line," in International Conference on Electrical, Electronics, and Optimization Techniques (ICEEOT), Chennai, India, 2016.
- [16]. Debnath, Suman, et al. "Operation, control, and applications of the modular multilevel converter: A review." IEEE transactions on power electronics 30.1 (2014): 37-53.
- [17]. Xu, Jianzhong, Penghao Zhao, and Chengyong Zhao. "Reliability analysis and redundancy configuration of MMC with hybrid submodule topologies." IEEE Transactions on Power Electronics 31.4 (2015): 2720-2729.
- [18]. Leon, Jose I., Sergio Vazquez, and Leopoldo G. Franquelo. "Multilevel converters: Control and modulation

- techniques for their operation and industrial applications." *Proceedings of the IEEE* 105.11 (2017): 2066-2081.
- [19]. M. Moazzami, G. B. Gharehpetian, H. Shahinzadeh, and S.H. Hosseinian, "Optimal locating and sizing of DG and DSTATCOM using Modified Shuffled Frog Leaping Algorithm," in *Proceedings of the 2nd Conference on Swarm Intelligence and Evolutionary Computation, CSIEC 2017*, pp. 54–59, Iran, March 2017.
- [20]. Safonova, A., Hamad, Y., Dmitriev, E., Georgiev, G., Trenkin, V., Georgieva, M., ... & Iliev, M. (2021). Individual tree crown delineation for the species classification and assessment of vital status of forest stands from UAV images. *Drones*, 5(3), 77.
- [21]. Kabaev, E., Hamad, Y., Simonov, K., & Zotin, A. (2020). Visualization and Analysis of the Shoulder Joint Biomechanics in Postoperative Rehabilitation. In *SibDATA* (pp. 34-41).
- [22]. Seno, M. E., Abed, A. A., Hamad, Y. A., Bhatt, U. M., Babu, B. R., & Bansal, S. (2022, December). Cloud Based Smart Kitchen Automation and Monitoring. In *2022 5th International Conference on Contemporary Computing and Informatics (IC3I)* (pp. 1544-1550). IEEE.
- [23]. Seno, M. E., Abed, A. A., Hamad, Y. A., Pundir, S., Srivastava, A. P., & Ali, S. (2022, December). Forwarding Factor Routing Protocol for Opportunistic Internet of Things Networks. In *2022 5th International Conference on Contemporary Computing and Informatics (IC3I)* (pp. 988-995). IEEE.
- [24]. Safonova, A., Hamad, Y., Alekhina, A., & Kaplun, D. (2022). Detection of norway spruce trees (*Picea Abies*) infested by bark beetle in UAV images using YOLOs architectures. *IEEE Access*, 10, 10384-10392.
- [25]. Mustafa, M. O., & Abbas, N. M. (2021). Harmonic Suppression Compensation of Photovoltaic Generation Using Cascaded Active Power Filter. *Eastern-European Journal of Enterprise Technologies*, 6(8), 114.
- [26]. Zainel, Q. M., Darwish, S. M., & Khorsheed, M. B. (2022). Employing quantum fruit fly optimization algorithm for solving three-dimensional chaotic equations. *Mathematics*, 10(21), 4147.