



POLİTEKNİK DERGİSİ

JOURNAL of POLYTECHNIC

ISSN: 1302-0900 (PRINT), ISSN: 2147-9429 (ONLINE)

URL: <http://dergipark.org.tr/politeknik>



Optimal placement of DGs in Northwest Anatolia power system by using a multi-objective genetic algorithm

Kuzeybatı Anadolu güç sisteminde dağıtık üretim kaynaklarının çok amaçlı genetik algoritma kullanılarak optimal yerleşimi

Authors: Rukiye B.AYMAZ¹, Mehmet Ali YALÇIN², Talha Enes GÜMÜŞ³, Erdal Mustafa YEĞİN³

ORCID¹: 0000-0002-1683-6190

ORCID²: 0000-0003-3846-177X

ORCID³: 0000-0002-6716-6414

ORCID⁴: 0000-0002-1665-3132

To cite to this article: B.Aymaz R., Yalçın M. A. and Gümüş T. E., Yeğın E. M., “Optimal Placement of DGs in Northwest Anatolia Power System by Using A Multi-Objective Genetic Algorithm”, *Journal of Polytechnic*, 28(5): 1493-1502, (2025).

Bu makaleye şu şekilde atıfta bulunabilirsiniz: B.Aymaz R., Yalçın M. A. ve Gümüş T. E., Yeğın E. M. “Optimal Placement of DGs in Northwest Anatolia Power System by Using A Multi-Objective Genetic Algorithm”, *Politeknik Dergisi*, 28(5): 1493-1502, (2025).

Erişim linki (To link to this article): <http://dergipark.org.tr/politeknik/archive>

DOI: 10.2339/politeknik.1481051

Optimal Placement of DGs in Northwest Anatolia Power System by Using a Multi-Objective Genetic Algorithm

Highlights

- ❖ The issue of determining the power and allocation for Distributed Generations (DGs) in the 114-bus Northwest Anatolia power system has been addressed.
- ❖ 4 different case was created, bus voltages, voltage stability index values and power losses were examined for each case.
- ❖ An evaluation was made against possible load increases in the power system.
- ❖ Voltage stability was achieved by bringing the index values closer to 1 pu in the buses.

Graphical Abstract

The flow diagram of the proposed algorithm is presented in the figure.

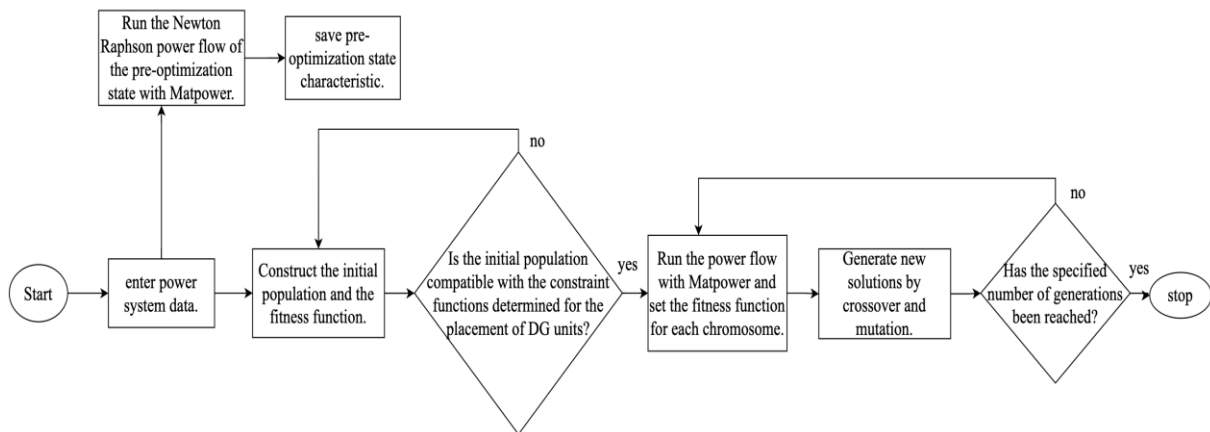

Figure. Flowchart of the proposed algorithm.

Aim

The goal of this article is to reduce power losses, bring the bus voltage values closer to 1 pu, sizing and allocation the DGs by keeping the index values within the desired range.

Design & Methodology

Network modelling, load flow analyses and genetic algorithm operations were performed in MATLAB m-file.

Originality

The originality of this paper is to investigate the bus voltage stability considering load increases.

Findings

Line losses are decreased, bus voltage values are enhanced and voltage stability index is increased within the desired range.

Conclusion

It is concluded that the addition of DGs with the proposed approach increases bus voltage values, contributes to bus voltages stability and reduces losses.

Declaration of Ethical Standards

The authors of this article declare that the materials and methods used in this study do not require ethical committee permission and/or legal-special permission.

Optimal Placement Allocation of DGs in Northwest Anatolia Power System by Using a Multi-Objective Genetic Algorithm

Araştırma Makalesi / Research Article

Rukiye B.AYMAZ^{1*}, Mehmet Ali YALÇIN², Talha Enes GÜMÜŞ², Erdal Mustafa YEĞİN¹

¹Engineering Faculty, Electrical Engineering, Kocaeli University, Türkiye

²Engineering Faculty, Electric-Electronic Engineering, Sakarya University, Türkiye

(Geliş/Received : 28.05.2024 ; Kabul/Accepted : 02.04.2025 ; Erken Görünüm/Early View : 26.04.2025)

ABSTRACT

The voltage profile and power losses of traditional network are influenced by the location, power and the number of Distributed Generation (DG) resources. To prevent the network from being adversely affected by DG resources, the integration of DG resources into the grid is done using various optimization methods. In this study, the allocation of DG resources in the Northwest Anatolian (NWA) power system with 114 buses, was discussed by using one of the most common optimization methods, the Genetic Algorithm (GA). For this purpose, minimizing active power losses, enhancement of voltage profile and maximization of voltage stability index were used as objective functions. 4 different cases were created and DG resources were integrated according to these cases. The power system was examined in terms of active power losses, index values and voltage profile. In two of these cases, load increase was made in the power system to evaluate the possible load increases that may occur during the operation. The simulation results verified the effectiveness of the recommended approach; the active power losses decreased, the voltage profile enhanced and the voltage stability index increased within the specified range. It has been observed that the proposed approach reduces losses in the power system by between 27.84% and 33.63% for different conditions.

Keywords: distributed generation, voltage stability index, multi-objective optimization.

Kuzeybatı Anadolu Güç Sisteminde Dağıtık Üretim Kaynaklarının Çok Amaçlı Genetik Algoritma Kullanılarak Optimal Yerleşimi

ÖZ

Geleneksel bir şebekenin gerilim profili ve güç kayıpları, dağıtık üretim kaynaklarının konumu, gücü ve sayısından etkilenmektedir. DG kaynaklarının şebekeyi olumsuz etkilemesini önlemek için, bu kaynakların entegrasyonu çeşitli optimizasyon yöntemleri kullanılarak gerçekleştirilmektedir. Bu çalışmada, 114 baraya sahip Kuzeybatı Anadolu güç sisteminde DG kaynaklarının tahsisi, en yaygın optimizasyon yöntemlerinden biri olan Genetik Algoritma (GA) kullanılarak ele alınmıştır. Bu amaçla, aktif güç kayıplarının minimum yapılması, gerilim seviyesinin iyileştirilmesi ve gerilim kararlılık indeksinin maksimum yapılması hedef fonksiyonlar olarak belirlenmiştir. Çalışmada 4 farklı senaryo oluşturulmuş ve DG kaynakları bu senaryolara göre entegre edilmiştir. Güç sistemi, aktif güç kayıpları, indeks değerleri ve gerilim profili açısından incelenmiştir. Bu senaryolardan ikisinde, işletme sırasında meydana gelebilecek olası yük artışlarını değerlendirmek amacıyla güç sisteminde yük artışı yapılmıştır. Simülasyon sonuçları, önerilen yaklaşımın etkinliğini doğrulamış; aktif güç kaybının azaldığını, gerilim seviyesinin iyileştiğini ve gerilim kararlılık indeksinin belirlenen aralık içinde arttığını göstermiştir. Önerilen yaklaşımın, güç sistemindeki kayıpları farklı çalışma koşullarına bağlı olarak %27,84 ile %33,63 arasında azalttığı gözlemlenmiştir.

Anahtar Kelimeler: dağıtık üretim, gerilim kararlılığı indeksi, çok amaçlı optimizasyon.

1. INTRODUCTION

The rise in DG resources has underscored the significance of stability assessment within power systems. In power systems, DG typically refers to electricity production units that utilize renewable energy sources and are positioned near consumption points for efficient integration [1], [2]. The integration of renewable energy sources, mostly consisting of wind, solar, etc., has been increasing in Türkiye. The installed power in our

country has reached 115.975 MW as of the end of December 2024, and the total electricity production in 2023 was 331,1 TWh. According to TEİAŞ 2023 annual report, when the primary generation sources of electricity in Turkey are reviewed, wind accounts for 11.806,1 MW and solar for 15.613,4 MW [3]. The main advantages of integrating DG resources to the power system can be listed as follows [4], [5]:

*Sorumlu Yazar (Corresponding Author)

e-posta : rukiye.baymaz@kocaeli.edu.tr

- Reducing of power losses,
- Improvement of voltage profile,
- Shorter time construction planning since it can be installed in locations close to the consumer,
- Reducing of stability problems,
- Reduced greenhouse gas emissions than conventional power plants,
- Reducing of harmonic distortion. The DGs can be used as a source in power systems or to provide energy during peak load.

The DGs can be independent of the system or used in network connection. To make DG controllable, power electronic inverters are often used as interfaces between the grid and renewable energy sources [6], [7]. Therefore, DG energy sources are often called inverter-based

generators [8]. They are integrated to the power system as microgrids to make the DG resources controllable. A grid-connected microgrid schema is given in Figure 1. If DG resources are integrated to the power system without detailed research, it is likely to have adverse effects on system security [9], stability and reliability [10], due to increases in the power losses [11] and the voltage [12], [13]. It is essential that the power system must still be stable after allocation of the distributed generation. Thus, the proposed methods must operate under certain constraints while integrating DG into the power system. There are many studies in the literature that include single and multiple objective functions for the allocation of DG resources [14], [15]. Some studies in the literature on distributed generation are given in Table 1.

Table 1. Some studies in the literature on the distributed generation.

Ref. No.	Objective	Types of DG	Proposed Method	Test System
[16]	Minimizing power loss of the system and enhancing reliability improvement and voltage profile	Supporting reactive power to system and absorbing real power from system	Dynamic programming	12 -Bus, 33-Bus and 69-Bus
[17]	Power loss minimization and the improvement of the voltage profile of the system	Real power support to system	Voltage index analysis, variational algorithm	25-Bus and IEEE 37-Bus
[18]	Allocating multiple DG	Real power support to system	Heuristic techniques	IEEE-69 Bus
[19]	Optimal allocation of DG	Real power support to system,	GA and PSO	IEEE-69 Bus
[20]	DG planning	Supporting reactive power to system and absorbing real power from system Real and reactive power support to system	GA	IEEE-30 Bus
[21]	production costs and costs of the power losses	Real and reactive power support to system	discrete PSO and OPF	IEEE-30 Bus
[22]	Power loss and voltage profile	Real and reactive power support to system	Whale optimization algorithm	36-Bus radial distribution system
[23]	Minimizing total energy loses	Real and reactive power support to system	Non-linear programming	IEEE 33-Bus and 404-bus distribution system
[24]	total operational emission, total operational cost and total active power loss	Real and reactive power support to system	fuzzy-embedded multi-objective particle swarm optimization	33-node droop controlled islanded microgrid test network
[25]	Power loss and voltage profile	Real and reactive power support to system	decision tree (DT) classification approach	IEEE 33 and 69 node distribution networks

In this study, the problem of integrating renewable energy sources to the NWA power system as a DG resource is discussed. The optimal connection points and power values of DG resources were determined using the genetic algorithm optimization method. Three different objective functions were used in the algorithm and 4 different cases were created. With the location and power information obtained from the algorithm, DG resources

were integrated to the power system and the results were examined. This study used genetic algorithms to tackle the multi-objective optimization problem. Since genetic algorithms gave good results in other studies, they were also used in this study. The use of Thevenin based voltage stability index in the objective function in this study reveals its difference from other studies.

In addition, since the connection points are integers, the integer efficiency of genetic algorithms was used [16].

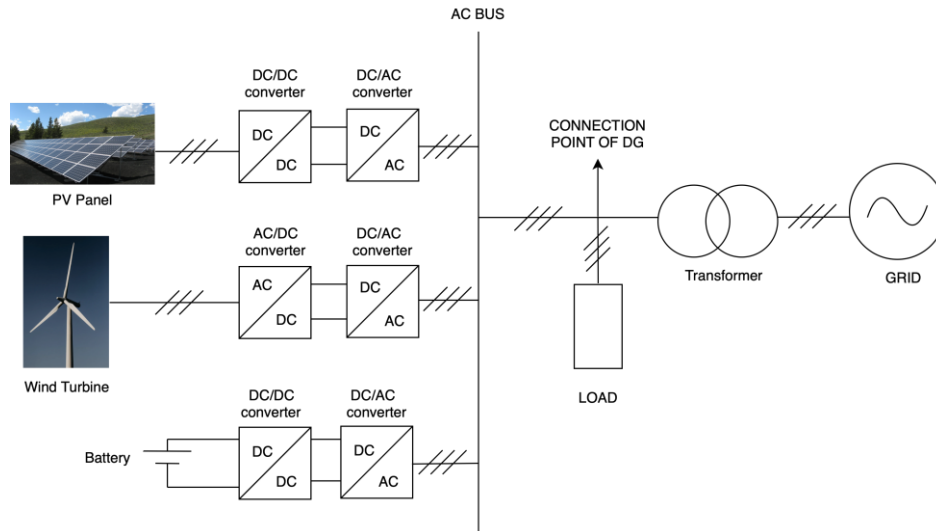

Figure 1. Grid-connected DG unit consisting of wind, solar and battery.

2. MATERIAL AND METHOD

The interconnected systems are partitioned regions, each controlled by its center. The NWA system, which is considered a sample region in this study, is one of these regions. [26]. The voltage level of 12 buses is 380 kV and

the voltage level of 102 buses is 154 kV. The operating voltage of the power system is 380 kV and 154 kV. 18 of 114 buses are production and 96 of them are load buses, 5 auto producers, 4 privates. The generation values of the generation plants in the NWA power system are given in Table 2.

Table 2. The generation values of the generation plants in the NWA power system (pu values are given on a 100 MVA base).

PRODUCTION VALUES OF GENERATION PLANTS IN NORTHWEST ANATOLIA POWER SYSTEM [26]				
Station Name	P (Pu)	Q (Pu)	P (MW)	Q (MVAR)
380 kV Ada DGKÇS 1	14,32	1,86	1432	186
380 kV Ada DGKÇS 2	7.22	0.72	722	72
380 kV Bursa DGKÇS	3.50	0.67	350	67
380 kV Tutes Şalt	1.05	0.05	105	5
380 kV Seyitömer	3.70	0.00	370	0
154 kV Çolakoğlu	4.74	1.16	474	116
154 kV Enerji Sa	0.41	0.04	41	4
154 kV Nuh Enerji	0.58	0.14	58	14
154 kV Entek 2	0.97	0.30	97	30
154 kV Sarıyar	1.60	0.17	160	17
154 kV Yeni Çates	2.28	0.97	228	97
154 kV Bozöyük Akenerji	1.11	0.18	111	18
154 kV Seyitömer	1.10	0.10	370	120
154 kV Tutes A	1.25	0.10	125	10
154 kV Tutes B	1.30	0.10	130	10
154 kV Bursa DGKÇS	7.15	1.35	715	135
154 kV Orhaneli	1.30	0.10	130	10
154 kV Entek 1	1.37	0.09	137	9

There are 7 thermal and 2 hydraulic power plants. In Table 2, the generation values of the generation plants in the NWA network are given in per unit (pu) values on a 100 MVA base. In this article, the default features of genetic algorithm in MATLAB Global Optimization Toolbox are used [27]. Figure 2 shows the flow chart of the proposed algorithm. The objective functions and constraints are presented in the following sections of the paper.

2.1. Objective Functions Used in the Optimization Problem

Three different objective functions are used in this paper. The objectives include minimizing active power losses, maximizing the voltage stability index and improving the voltage profiles of system buses.

2.1.1. Minimization of power loss

First objective function is $\min Total P_{loss}$ in the NWA power system. The objective function is formulated as given in Equation 2.1.

$$\min Total P_{loss} = \sum_{k=1}^{N_{line}} R_{line} \cdot I_{line}^2 \quad (2.1)$$

Where R_{line} is the line resistance, I_{line} is the line current.

2.1.2. Improvement of the voltage profile

The 2nd objective function is to set all bus voltages in the system approximately to 1 pu. Therefore, the 2nd objective function is formulated as given in Equation 2.2.

$$\min VD = \sum_{i=1}^N (1 - V_i)^2 \quad (2.2)$$

In Equation 2.2, i represent the relevant bus number and N represent the total bus number.

2.1.3. Maximizing the voltage stability index

The third objective function is maximizing the voltage stability index. The voltage stability index gives information about the stability of the system. The index varies between 0 and 1, and if it approaches 0, it is concluded that the bus approaches instability [28]. In Figure 3, the equivalent circuit is shown from the bus k , the selected bus to be evaluated in terms of voltage stability. The Thevenin equivalent is a simple two-node system with one input and output, simplifying the complex power system. Using the Thevenin equivalent, the critical voltage value of the bus to be evaluated for voltage stability is calculated. The critical voltage value is calculated under the assumption that the value of the load impedance and Thevenin impedance are identical. The voltage stability index is given in equation 2.4. The critical voltage is given equation 2.3.

$$V_{critical} = \frac{E_{th}}{2 \cos \delta} \quad (2.3)$$

$$VSM_v = \frac{V_{measured} - V_{critical}}{V_{critical}} \quad (2.4)$$

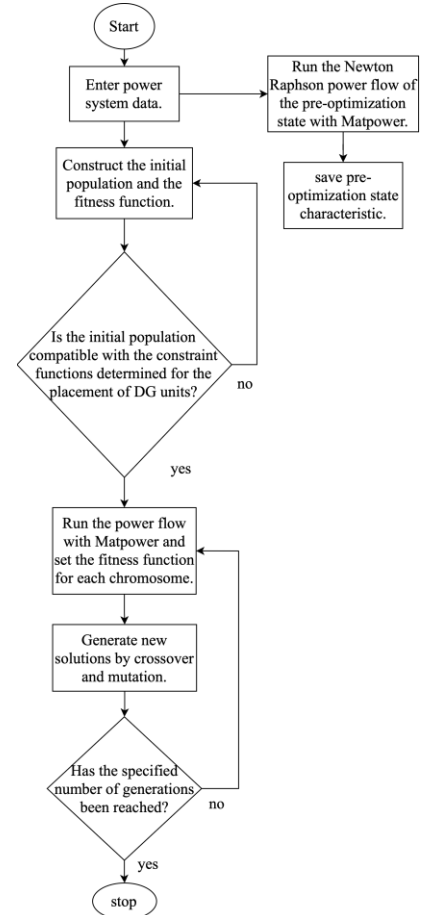

Figure 2. Flowchart of the proposed algorithm.

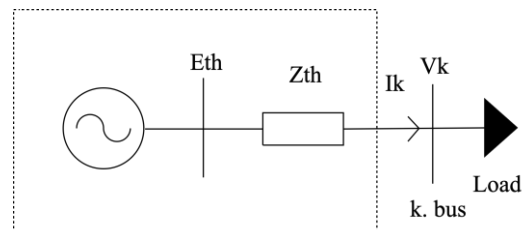

Figure 3. Thevenin equivalent circuit from the k th bus.

2.2. Constraints

For the power system to be stable in terms of voltage stability, both voltage and power value must be kept within acceptable limits in case load increases. In the optimization problem, the constraint that the capacity of the DG to be integrated into the power system is less than the total load value in the system that has been added. Additionally, keeping the voltage values of all buses in the system between 0.95-1.05 pu has been added as a constraint. The constraint functions are given in Equations 2.5 and 2.6.

$$\sum P_{DG} < \sum P_{Load} \quad (2.5)$$

$$0.95 < V_{bus} < 1.05 \quad (2.6)$$

Table 3. The objective functions, load conditions, and the DG capacity values added in the four distinct scenarios investigated.

Case	Objective Function	Load Condition	DG power to be added
Case 1	$\min TotalP_{Loss}$ $\min VD$	No changes have been made to the load values of the NWA power system.	DG power is determined as 24.38% of the power value produced by the power system.
Case 2	$\min TotalP_{Loss}$ $\min VD$ $\text{maks } VSM_v$	No changes have been made to the load values of the NWA power system.	DG power is determined as 26.55% of the power value produced by the power system.
Case 3	$\min TotalP_{Loss}$ $\min VD$	Load ratings of the NWA power system increased by 8% [3].	DG power is determined as 23.92% of the power value produced by the power system.
Case 4	$\min TotalP_{Loss}$ $\min VD$ $\text{maks } VSM_v$	Load ratings of the NWA power system increased by 8% [3].	DG power is determined as 24.51% of the power value produced by the power system.

3. RESULTS

The 4 cases presented for the solution of the optimization problem are given in table 3. Detailed information for each case will be provided in sections 3.1, 3.2, 3.3, and 3.4.

3.1. Case 1

The objective functions presented in Equations 2.1 and 2.2 are used in Case 1. The constraints given by equation 2.5 and equation 2.6 are used. The system load is used without modifying the load data of power system. In Table 4 the power values of the bus and DG resources integrated into the NWA power system for Case 1 are given. The total additional DG power constitutes 24.38% of the total production of the NWA power system before optimization.

The buses where the DG resources will be added are the 13th, 15th, 16th, 19th, 22nd, 24th, 25th, 26th, 32nd and 103rd buses. The proposed algorithm in Case 1 has added a DG system to a capacity of 24.38% of the production capacity of the NWA power system. Figure 4 shows the voltage profile of Case 1. The pre-optimization voltage

profile of the NWA power system and the post-optimization voltage profile were compared. In Table 5, the active power losses of the NWA power system before and after optimization are given. After adding DG resources, it has been observed that active power losses in Case 1 decreased from 283.31 MW to 204.42 MW.

3.2. Case 2

Objective functions 1, 2 and 3 are used in Case 2. The objective functions are given in equation 2.1, equation 2.2, and equation 2.4, respectively. The constraints given by Equation 2.5 and Equation 2.6 are used. Load values are used without changing the load values of the NWA power system. In Table 6, DGs and index values to be added power system according to Case 2 are given. The additional total DG constitutes 26.55% of the total production of NWA power system before optimization. The buses where DG resources will be integrated are given in Table 6. DG placement was made in Case 2 with the proposed algorithm, and DG, with a capacity of 26.55% of the total production capacity of the power system, was added. Details of the analyses after adding DG resources are given.

Table 4. According to Case 1, the Distributed Generations (DGs) to be integrated into the power system are determined.

Bus	Power of DG (MW)
13	235.5587
15	238.9561
16	223.5597
19	229.7044
22	211.1126
24	234.3709
25	128.7376
26	238.7255
32	121.6427
103	88.3326

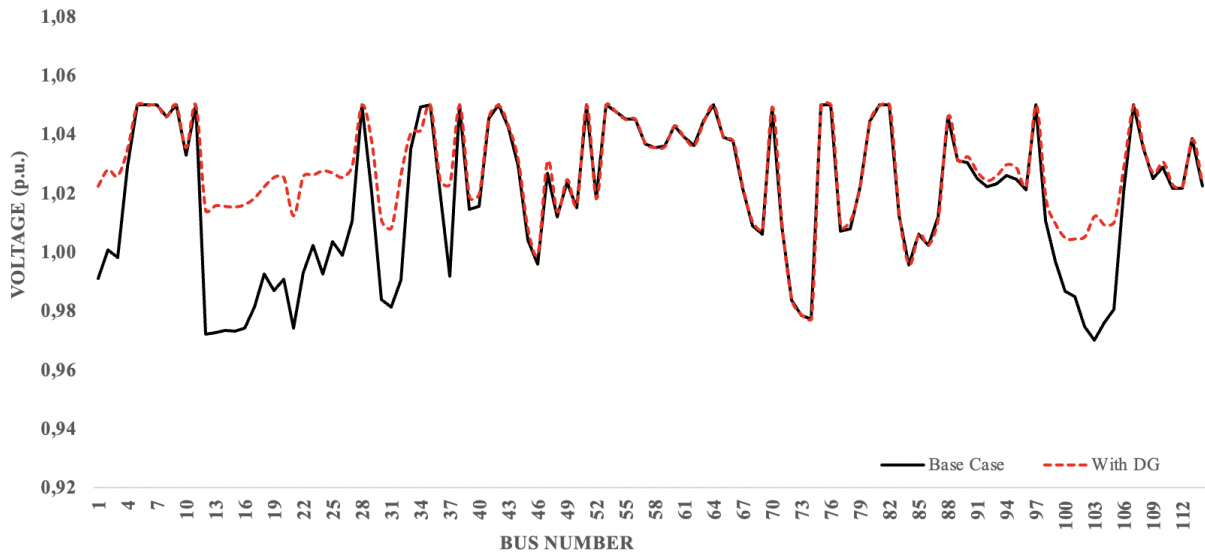

Figure 4. Voltage profile of Case 1.

Table 5. Active power losses according to Case 1.

Base Case Loss	With DG Loss
P_{Loss} (MW)	P_{Loss} (MW)
283.31	204.42

Table 6. DGs and index values to be added power system according to Case 2.

Base Case VSM_v	With DG VSM_v	Bus	Power of DG (MW)
0,98	1,00	13	215.9600
0,94	0,98	15	249.8649
0,98	1,00	16	246.2697
0,98	0,99	18	249.8703
0,97	0,99	19	223.1123
0,99	1,00	22	206.8930
0,97	0,99	23	160.1013
0,97	0,99	24	243.2513
0,98	0,99	26	236.7288
0,94	1,00	103	91.9225

Figure 5 illustrates the voltage profile of Case 2. The pre-optimization voltage profile of the NWA power system and the post-optimization voltage profile were compared. In Table 7, the active power losses are given for Case 2. After optimization, it has been observed that active power losses decreased from 283.31 MW to 204.14 MW by adding DG resources in Case 2.

Table 7. Active power losses according to Case 2.

Base Case Loss	With DG Loss
P_{Loss} (MW)	P_{Loss} (MW)
283.31	204.14

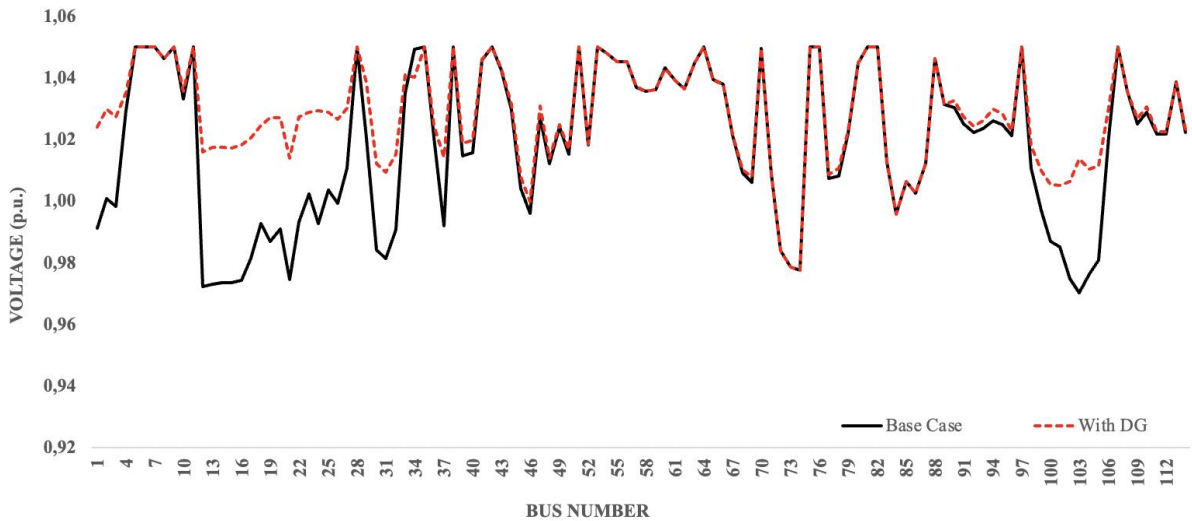

Figure 5. Voltage profile of Case 2.

3.3. Case 3

Objective functions 1 and 2 are used in Case 3. The objective functions are given in equation 2.1 and equation 2.2, respectively. The constraints given by Equation 2.5 and Equation 2.6 are used. The load values of the NWA power system are used by increasing the load data by 8%. In Table 8, DGs to be added to the power system according to Case 3 are given. The additional DG constitutes 23.92% of the total production of the power system before optimization. DGs will be integrated into the 13th, 15th, 16th, 20th, 21st, 23rd, 24th,

30th, 32nd and 103rd buses. The proposed algorithm has been applied for Case 3, and DG resources with a size of 23.92% of the total generation power have been added to the NWA power system. Details of the situation after optimization are given. Figure 6 shows the voltage profile of Case 3. The pre-optimization voltage profile of the NWA power system and the post-optimization voltage profile were compared. In Table 9, the active power losses before and after optimization of the NWA power system for Case 3 are given. If DG resources were added according to Case 3, it was found that P_{Loss} decreased from 283.31 MW to 188,024 MW.

Table 8. According to Case 3, the Distributed Generations (DGs) to be integrated into the power system are determined.

Bus	Power of DG (MW)
13	228.2228
15	243.1686
16	220.5422
20	245.9556
21	189.7756
23	220.2021
24	243.7229
30	101.0931
32	132.7693
103	88.0978

Table 9. Active power losses according to Case 3.

Base Case Loss	With DG Loss
P_{Loss} (MW)	P_{Loss} (MW)
283.31	188.024

3.4. Case 4

Objective functions 1, 2 and 3 are used in Case 4. The objective functions are given in Equation 2.1, 2.2 and 2.4, respectively. The constraints given by Equation 2.5 and Equation 2.6 are employed. The load data of the NWA power system are used after being increased by 8%.

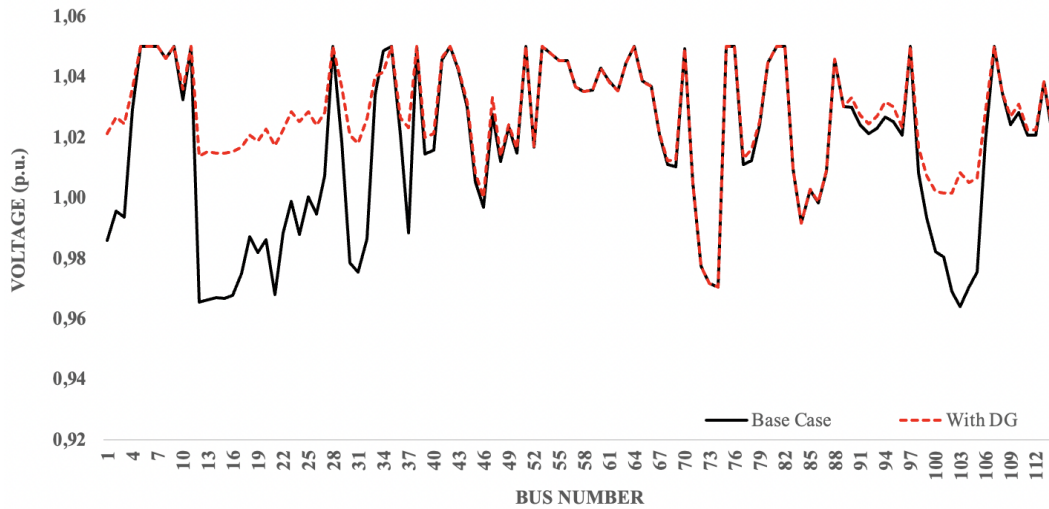

Figure 6. Voltage profile for Case.

The total DG power to be added constitutes 24.51% of the total production of the power system before optimization. The buses where DG resources are added the 15th, 16th, 19th, 21st, 23rd, 24th, 30th, 32nd, 73rd and 102nd buses. Table 10 gives DGs and index values to be added power system according to Case 4. With the algorithm proposed for Case 4, DG resources with a total size of 24.51% of the production power of the power

system were added to the system, and the results of the post-optimization situation have been given.

Figure 7 illustrates the voltage profile of Case 4. The pre-optimization voltage profile of the NWA power system and the post-optimization voltage profile have been compared. Table 11 shows the active power losses for Case 4. After the optimization, it has been observed that active power losses decreased from 283.31 MW to 190,565 MW

Table 10. DGs and index values to be added power system according to Case 4.

Base Case VSM_v	With DG VSM_v	Bus	Power of DG (MW)
0,98	1,00	15	247.8381
0,98	0,98	16	249.7030
0,98	0,98	19	247.3079
0,98	0,99	21	237.5054
0,97	0,99	23	249.5143
0,96	0,97	24	249.3309
0,97	0,98	30	144.6978
0,98	0,98	32	176.1921
0,97	0,97	73	0.0606
0,93	0,95	102	158.8862

Table 11. Active power losses according to Case 4.

Base Case Loss	With DG Loss
P_{Loss} (MW)	P_{Loss} (MW)
283.31	190.565

4. DISCUSSION

The allocation and sizing problem of DG resources in the NWA power system consisting of 114 buses, is solved by using the GA optimization method. Three objective functions are used. Four different Cases have been created, and these Cases have been applied to the NWA power system. To examine the network behavior when the load demands on the user side rise, load increases have been applied in 2 out of the 4 Cases.

In Case 1, the equations expressed in Equations 2.1 and 2.2 represent the objective functions. If DG resources are installed at the positions and power values specified in Case 1, it has been observed that the voltage profile for both the buses with DG resources and the other buses improved, while the active power losses were reduced by 27.85%.

For Case 2, the objective functions expressed by Equations 2.1, 2.2 and 2.3 are used. When DGs are placed according to Case 2, the voltage profile improves, and active power losses are reduced by 27.94%. When the index values were compared to those before optimization, it was found that they increased, indicating that the voltage stability is improved.

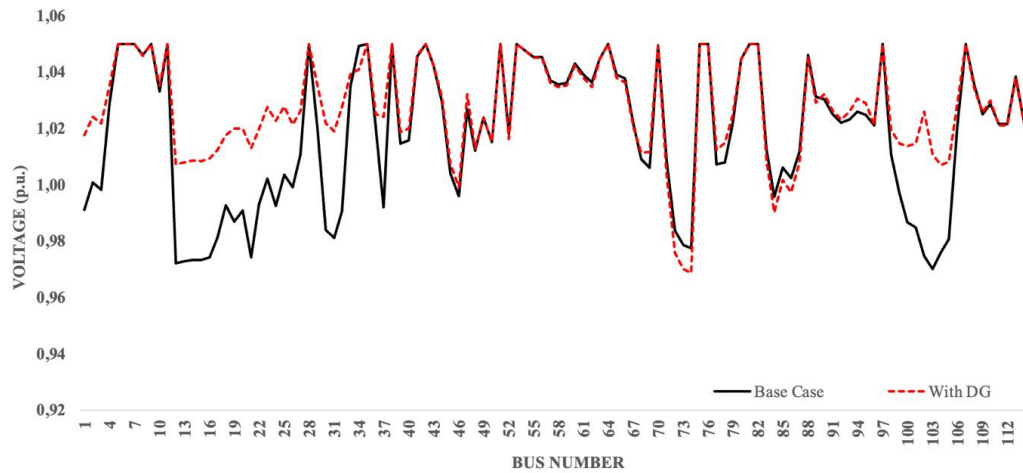

Figure 7. Voltage profile for Case 4.

In Case 3, the objective functions expressed by Equations 2.1, 2.2 are applied. The load in the NWA power system have been increased by 8%. If DG resources are added at the positions and power values specified in Case 3, it is observed that the voltage profile improves, and the active power losses decrease by 33.63%.

For Case 4, the objective functions expressed by Equations 2.1, 2.2 and 2.3 are applied. The load in the NWA power system have been increased by 8%. When DG resources are placed according to Case 4, it is observed that the voltage profile enhances, and the active power losses decrease by 32.74%. Index values increased after optimization showing that system became more stable.

When all Cases were examined, it was observed that the active power losses of the power system decreased, the voltage profile enhanced, and the voltage stability index increased due to the allocation of the DGs in the power system with the proposed approach.

5. CONCLUSION

This study solved the optimal DG placement and sizing problem using genetic algorithms. The objective function of the optimization problem aims to reduce active power losses, enhance the voltage profile, and maximize the Thevenin-based voltage stability index. The proposed approach has been applied to the NWA power system for four different scenarios. For Case 1, the real power loss is reduced to 204.42 MW from 283.31 MW. For Cases 2,3 and 4, it reduced to 204.14 MW, 188.024 MW, and 190.565 MW, respectively. Active power losses have been reduced by %27.84, %27.94, %33.63 and %32.72 for all Cases, respectively. It has been observed that losses decrease, voltage levels enhance, and the stability index increases for each scenario. The DG placement and sizing problem can be solved using different stability indices and optimization techniques. Furthermore, the optimization problem can be solved using dynamic load models instead of existing ones. This will ensure that the analyzed power system is closer to the real system.

Analysis made with dynamic load models will provide a more stable system operation.

DECLARATION OF ETHICAL STANDARDS

The authors of this article declare that the materials and methods used in this study do not require ethical committee permission and/or legal-special permission.

AUTHORS' CONTRIBUTIONS

Rukiye B. AYMAZ: Performed the simulation, implementation of case, reported the results.

Talha Enes GÜMÜŞ: Performed the simulation, implementation of case, reported the results.

Mehmet Ali YALÇIN: Performed the simulation, implementation of case, reported the results. Managed the writing process of the article.

Mustafa Erdal YEĞİN: Performed the simulation, implementation of case, reported the results. Managed the writing process of the article.

CONFLICT OF INTEREST

There is no conflict of interest in this study.

REFERENCES

- [1] Ackermann, T., Ran Andersson, G. ve Sö Der A, L. 'Distributed generation: a definition.' **Electric Power Systems Research**, 57, 195–204, (2001).
- [2] G. Pepermans, J. Driesen, D. Haeseldonckx, R. Belmans, and W. D'haeseleer, "Distributed generation: definition, benefits and issues," **Energy Policy**, 33(6), 787–798, (2005)
- [3] Türkiye Elektrik İletim Anonim Şirketi, "Türkiye Elektrik İletim Anonim Şirketi Teiaş 2021 Yılı Faaliyet Raporu." [Online]. Available:<https://www.teias.gov.tr/faaliyet-raporlari> , (2021).
- [4] J. A. Sa'ed, M. K. Jubran, S. Favuzza, and F. Massaro, "Reassessment of voltage stability for distribution networks in presence of DG", **IEEE 16th International Conference on Environment and Electrical Engineering (EEEIC)**, 1-5, (2016).

- [5] N. Dkhili, J. Eynard, S. Thil, and S. Grieu, "A survey of modelling and smart management tools for power grids with prolific distributed generation," *Sustainable Energy, Grids and Networks*, 21(100284), (2020).
- [6] S. Mashayekh, M. Stadler, G. Cardoso, and M. Heleno, "A mixed integer linear programming approach for optimal DER portfolio, sizing, and placement in multi-energy microgrids," *Applied Energy*, 187(154-168), (2016).
- [7] A. A. M. Frrı ve M. T. Guneser, "Belirsiz Yük Koşullarında Bir Dek Sisteminin Pratik Radyal Dağıtım Besleyicide Tekno-ekonomik ve Çevresel Analizi", *Politeknik Dergisi*, 26(2),731–741, (2023).
- [8] N. Hosseinzadeh, A. Aziz, A. Mahmud, A. Gargoom, and M. Rabbani, "Voltage stability of power systems with renewable-energy inverter-based generators: A review," *Electronics (Switzerland)*, 10(2), (2021).
- [9] I. Oladeji, R. Zamora, and T. T. Lie, "Security constrained optimal placement of renewable energy sources distributed generation for modern grid operations," *Sustainable Energy, Grids and Networks*, 32(100897), (2022).
- [10] H. Hashemi-Dezaki, A.-M. Hariri, and M. A. Hejazi, "Impacts of load modeling on generalized analytical reliability assessment of smart grid under various penetration levels of wind/solar/non-renewable distributed generations," *Sustainable Energy, Grids and Networks*, 20, (2019).
- [11] S. L. Gbadamosi and N. I. Nwulu, "A comparative analysis of generation and transmission expansion planning models for power loss minimization," *Sustainable Energy, Grids and Networks*, 26(100456), (2021).
- [12] D. H. Popović, J. A. Greatbanks, M. Begović, and A. Pregelj, "Placement of distributed generators and reclosers for distribution network security and reliability," *International Journal of Electrical Power and Energy Systems*, 27(5–6), 398–408, (2005).
- [13] S. Heslop, I. Macgill, and J. Fletcher, "Maximum PV generation estimation method for residential low voltage feeders," *Sustainable Energy, Grids and Networks*, 7, 58–69, (2016).
- [14] J. Bojod and B. Erkal, "Practical Radial Distribution Feeder for Techno Economic in DERs based on ANN and Chameleon Optimization Algorithms", *Politeknik Dergisi*, 26(3),1285–1297, (2023).
- [15] Z. Öztürk ve A. Demirci, "Yenilenebilir Enerji Kaynaklı Hibrit Güç Sistemlerinin Farklı Penetrasyon ve Şebeke Tarifeleri Altında Optimizasyonu", *Politeknik Dergisi*, 26(3), 1267–1275, (2023).
- [16] R. B. Aymaz, "The effects of renewable energy sources on voltage stability in Northwest Anatolia power system," *M.S. thesis*, Dept. of Electrical Engineering, Inst. of Sci., Sakarya Univ., Sakarya, Türkiye, 2022.
- [17] N. Khalesi, N. Rezaei, and M. R. Haghifam, "DG allocation with application of dynamic programming for loss reduction and reliability improvement," *International Journal of Electrical Power & Energy Systems*, 33(2), 288–295, (2011).
- [18] J. B. V. Subrahmanyam and C. Radhakrishna, "Distributed generator placement and sizing in unbalanced radial distribution system," *International Journal of Electrical and Computer Engineering*, vol. 3(4), 753–760, (2009).
- [19] A. Elmitwally, "A new algorithm for allocating multiple distributed generation units based on load centroid concept," *Alexandria Engineering Journal*, 52(4), 655–663, (2013).
- [20] R. Shi, C. Cui, K. Su, and Z. Zain, "Comparison Study of Two Meta-heuristic Algorithms with their Applications to Distributed Generation Planning," *Energy Procedia*, 12, 245–252, (2011).
- [21] B. Poornazaryan, P. Karimyan, G. B. Gharehpetian, and M. Abedi, "Optimal allocation and sizing of DG units considering voltage stability, losses and load variations," *International Journal of Electrical Power & Energy Systems*, 79, 42–52, (2016).
- [22] M. Gomez-Gonzalez, A. López, and F. Jurado, "Optimization of distributed generation systems using a new discrete PSO and OPF," *Electric Power Systems Research*, 84(1), 174–180, (2012).
- [23] T. Boonraksa, P. Boonraksa, B. Marungsri, and S. L. L. Wynn, "Location and Sizing Optimization of Distributed Generation Systems on Smart Grid with the Whale Optimization Algorithm," in *Proceeding of the 2021 9th International Electrical Engineering Congress, IEECON 2021*, 81–84, (2021).
- [24] S. Md. R. H. Shawon, X. Liang, and M. Janbakhsh, "Optimal Placement of Distributed Generation Units for Microgrid Planning in Distribution Networks," *IEEE Trans Ind Appl*, 1–11, (2023).
- [25] N. B. Roy and D. Das, "Optimal allocation of active and reactive power of dispatchable distributed generators in a droop controlled islanded microgrid considering renewable generation and load demand uncertainties," *Sustainable Energy, Grids and Networks*, 27(100482), (2021).
- [26] I. Oladeji, R. Zamora, and T. T. Lie, "Security constrained optimal placement of renewable energy sources distributed generation for modern grid operations," *Sustainable Energy, Grids and Networks*, 32(100897), (2022).
- [27] E. M. Nihat, "380 ve 154 kv'luk kuzeybatı anadolu ebekesi güç akı benzetimleri", *master thesis*, Sakarya University, Faculty of Engineering, (2009).
- [28] Matlab MathWorks. (2022, 3 Mayıs). Genetic Algorithm Options Options for Genetic Algorithm. <https://www.mathworks.com/help/gads/genetic-algorithm.html>
- [29] G. T. Enes, "Sözde Thevenin Eşdeğer Devre Parametreleri Kullanılarak Güç Sistemlerinde Gerilim Kararlılığı Değerlendirmesi", *phd thesis*, Sakarya University, Faculty of Engineering, (2021).