

Diagnostic of Inverter Seven Levels Associated with Asynchronous Machine

K. Mendaz, H. Bounoua, M. Feliti, H. Miloudi

Abstract— this article presented the diagnostic of the inverters multi levels associates with the three-phase asynchronous squirrel-cage machines. That shows the faults of the switches for each inverter multi levels and their influence on the answers speed and torque.

Index Terms-asynchronous machine, diagnostic, inverters seven levels.

I. INTRODUCTION

THE voltage source inverters is consisting a non controllable function in the power electronic, it is used in the variable methods application. The strategy obtaining by this technique is based on the study of speed variation in induction machine. The strong evolution of this function was based, on the one hand, on the development of semi-conductor components entirely commendable, powerful, robust and fast, and on the other hand, on the quasi generalized use of the techniques known as pulse width modulated [1, 2].

II. STRUCTURE OF THE INVERTERS HAS SEVEN LEVELS

The three-phase inverter on seven levels with structure studies in this paragraph consists of three symmetrical arms and six sources of equal continuous voltage. Each arm comprises twelve switches of which eight are in series and four in parallel, like two diodes for the zero setting of the arm of the inverter. Each switch is composed of a GTO and of a diode assembled at the head digs as it is shown in the Fig.1 for this inverter; we chose the complementary order defined as follows [2, 4].

$$B_{k5} = \bar{B}_{k3}, \quad B_{k6} = \bar{B}_{k4}, \quad B_{k7} = \bar{B}_{k1}$$

$$B_{k8} = \bar{B}_{k2}$$

K.Mendaz, Sidi Bel Abbes University, department of electrical engineering /Algeria (email:kheiramendez@yahoo.fr)
 H.Bounoua, Sidi Bel Abbes University, department of electrical engineering /Algeria (email: hsemmach@yahoo.fr)
 M.Feliti, Sidi Bel Abbes University, department of electrical engineering /Algeria (email: FLiti-Med@yahoo.fr)
 H.Miloudi, Sidi Bel Abbes University, department of electrical engineering /Algeria (email: al_houssaine@yahoo.fr)

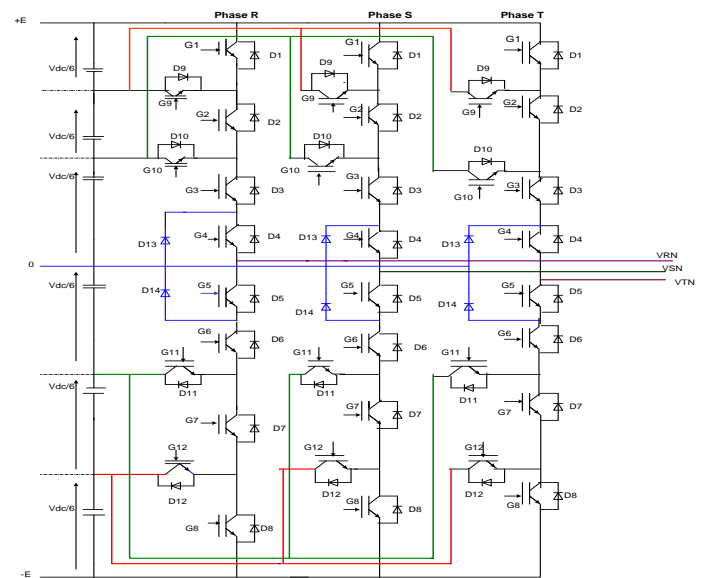

Fig.1 .The inverter seven levels structural

III. VARIOUS CONFIGURATIONS OF AN ARM OF THE INVERTER HAS SEVEN LEVELS

A topological analysis of an arm of the inverter shows seven possible configurations for this last. These various configurations are represented for the Fig.3 to the Fig. 6. 1st configuration: [1 1 1 1 0 0 0 0 0 0 0]

To obtained the configuration of the Fig. 3. a. One must order the four switches B_{k1} to B_{k4} with state 1 and the others remain with state 0. Thus, the value of voltage V_{R0} is defined by the equation (1).

$$V_{R0} = (B_3 \cdot B_4) \frac{E}{3} + B_2 \frac{E}{3} + B_1 \frac{E}{3} = \frac{V_{dc}}{2} \tag{1}$$

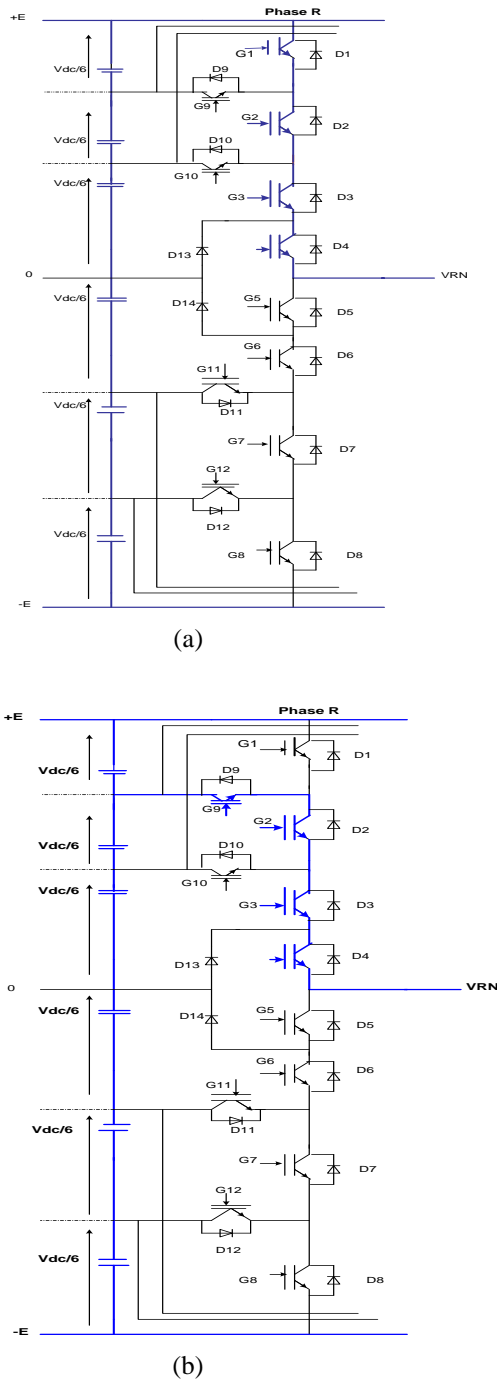

Fig.3. Different configurations from an arm of inverter on seven levels

2nd configuration: [0 1 1 1 0 0 0 0 1 0 0 0]

This configuration is represented by the Fig.3.b of which the ordering of the following switches B₂, B₃, B₄ and B₉, with the state 1 and others with state 0. The equation (2) gives the value of voltage V_{R0} as follows.

$$V_{R0} = (B_3 \cdot B_4) \frac{E}{3} + (B_2 \cdot B_9) \frac{E}{3} = \frac{2E}{3} = \frac{V_{dc}}{2} \quad (2)$$

3rd configuration:

[0 0 1 1 0 0 0 0 0 1 0 0]

This configuration is represented by the Fig.4.a dowry the ordering of the B₃ switches, B₄ and B₁₀ are with state 1 and the remainder of the switches is with state 0. The value of voltage V_{R0} is given by the equation (3).

$$V_{R0} = (B_3 \cdot B_4 \cdot B_{10}) \frac{E}{3} = \frac{E}{3} = \frac{V_{dc}}{6} \quad (3)$$

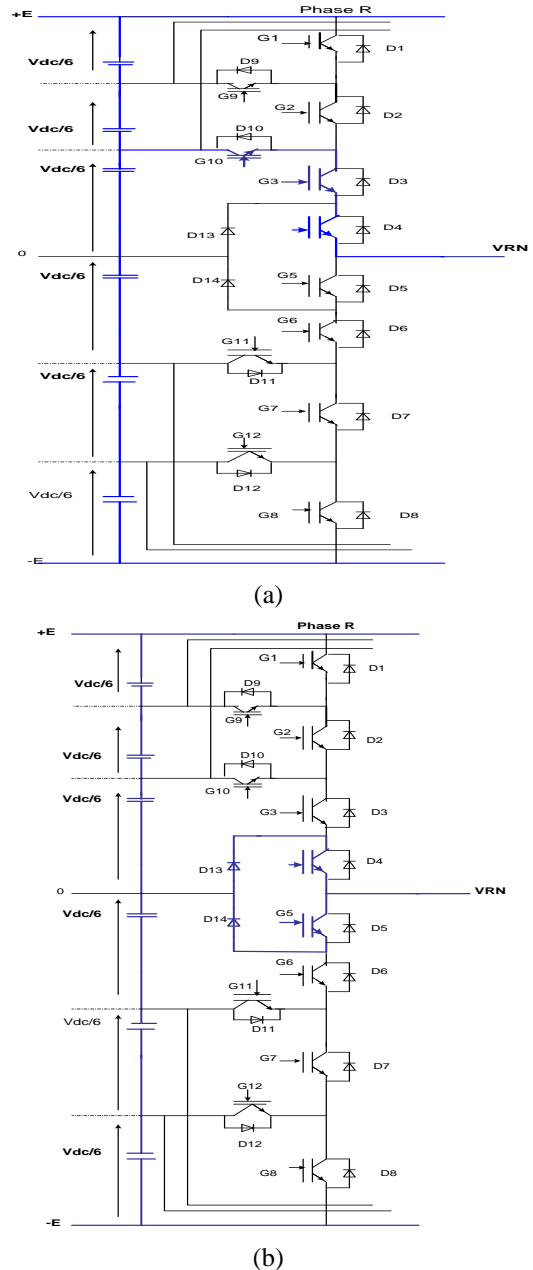

Fig.4 .Different configurations from an arm of inverter on seven levels

4th configuration :

[0 0 0 1 1 0 0 0 0 0 0 0]

It is the phase of zero setting of the arm of the inverter or the diodes D₁₃ et D₁₄ return in conduction to ensure the flow of the current. Voltage V_{R0} takes value 0.

5th configuration:

[0 0 0 0 1 1 0 0 0 0 1 0]

The configuration of the Fig. 7.a. has given the switch to state 1 to form the negative part of voltage V_{R0} , this configuration is translated by the equation (4).

$$V_{R0} = (B_5 \cdot B_6 \cdot B_{11}) \left(-\frac{E}{3}\right) = -\frac{E}{3} = -\frac{V_{dc}}{6} \quad (4)$$

6th configuration:

$$[0 \ 0 \ 0 \ 0 \ 1 \ 1 \ 1 \ 0 \ 0 \ 0 \ 0 \ 1]$$

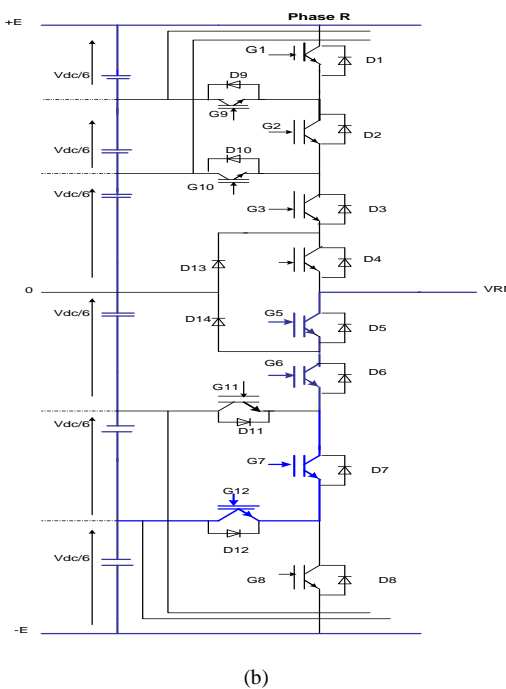
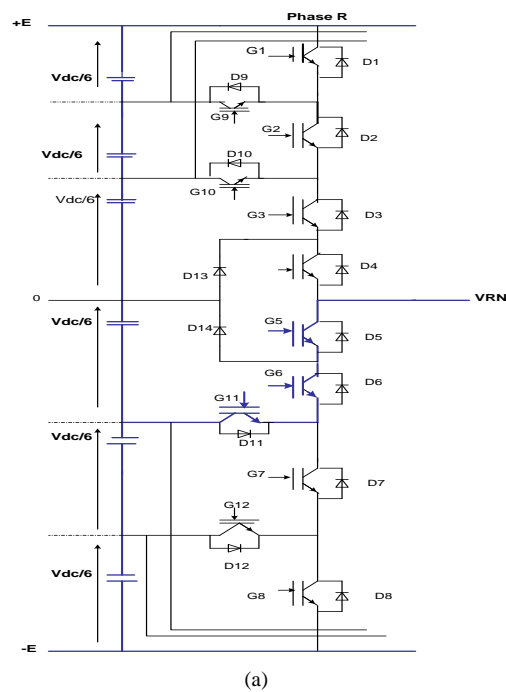

Fig.5 .Different configurations from an arm of inverter on seven levels

The configuration of the Fig. 5.b requires the ordering of the following switches B_5, B_6, B_7 and B_{12} ; they must be with state 1 and the other with state 0. The equation (5) gives the value of voltage V_{R0} as follows.

$$V_{R0} = (B_5 \cdot B_6) \left(-\frac{E}{3}\right) + (B_7 \cdot B_{12}) \left(-\frac{E}{3}\right) = -\frac{2E}{3} = -\frac{V_{dc}}{3} \quad (5)$$

7th configuration :

$$[0 \ 0 \ 0 \ 0 \ 1 \ 1 \ 1 \ 1 \ 0 \ 0 \ 0 \ 0]$$

This configuration produced - E, the switches in conduction is B_5, B_9, B_7 and B_8 and the remainder of the switches is in a blocked state and tension V_{R0} is given by the equation (6).

$$V_{R0} = (B_5 \cdot B_6) \left(-\frac{E}{3}\right) + B_7 \left(-\frac{E}{3}\right) + B_8 \left(-\frac{E}{3}\right) = -E = -\frac{V_{dc}}{2} \quad (6)$$

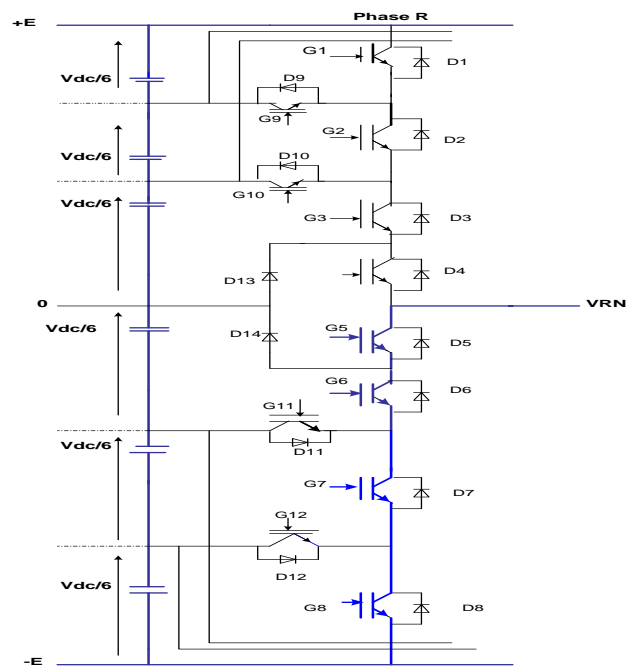

Fig.6. Application of complete and negative voltage.

IV. DIAGNOSTICS FAULTS OF INVERTER MULTI LEVELS

The application domains of the three-phase inverters of voltage most known in industry are undoubtedly that of the electric drives at variable speed. The three-phase inverters, in spite of their qualities, which have pushed to reach thanks to the development of the power electronics, and the use quasi-generalized of the techniques known as of “pulse width modulation”, can present a structural fault such as the fault of closing of the semiconductors. This type of induced dysfunction of the constraints can be damages for the systems of production if the personnel are not informed and that a spurious shutdown is produced. Since, the equipment of protection intervenes only at the last stage of fault; it is thus obvious, that the investment in the field of the

detection of the dysfunctions appears a solution impossible to circumvent [7, 8].

Many faults of the inverters multi levels is detected by using overpressures and the over currents of current system. However, the detection of fault of the elements of commutation is very difficult because the voltage and the current according to each fault of commutation decrease quickly compared to the normal functioning. The disequilibrium of the continuous voltage at the input of the inverter multi levels, as the faults occur, causes serious problem for the protection and the reliability of the system [2, 3, 5].

The fault of K_{17} and k_{12} induces a disequilibrium in the three phases, which translates by the discharge of the lower condensers of the arm R of the inverter five levels [2, 3, 7].

A. DIAGNOSTICS FAULTS OF INVERTER SEVEN LEVELS

In the inverter seven levels, the voltage of phases represented twenty and one levels under symmetrical functional, but their levels of voltage seem to be different with each fault from commutation. The voltage of phase for the positive period has only eight levels because the current of phase crosses the K_{19} switch instead of K_{11} in the state of P (positive). In the event of fault of commutation of K_{110} , the voltage of phase for the positive period has only six levels because the current of phase crosses the K_{110} switch in the state of P (positive). In the event of fault of commutation of K_{13} , the voltage of phase for the positive period has only four levels because the current of phase crosses the K_{14} switch in the P (positive). Consequently, when each fault of commutation occurs, the fictitious voltage differently appeared between them [2, 5, 6, 8].

V. RESULT SIMULATION

For the inverter 7 levels, the Fig.7.b represents the simple voltage V_{an} , the phase voltage V_{ab} is illustrated by the Fig.7.a.

Fig.8 shows also the result of speed and electromagnetic torque were shows that the torque varied then starting to stabilize in the permanent regime.

From the faults of the K_{19} switches of the inverter 7 levels the form of V_{an} voltage and the currents I_{ra} , I_{sa} resulting represented by the Fig.10 and Fig.12 which shows the effect of these faults on disequilibrium of the currents.

The Fig.11 show the conduit of the asynchronous machine, during and after the fault which translates by oscillation of torque and variation speed for the fault of the switch K_{19} .

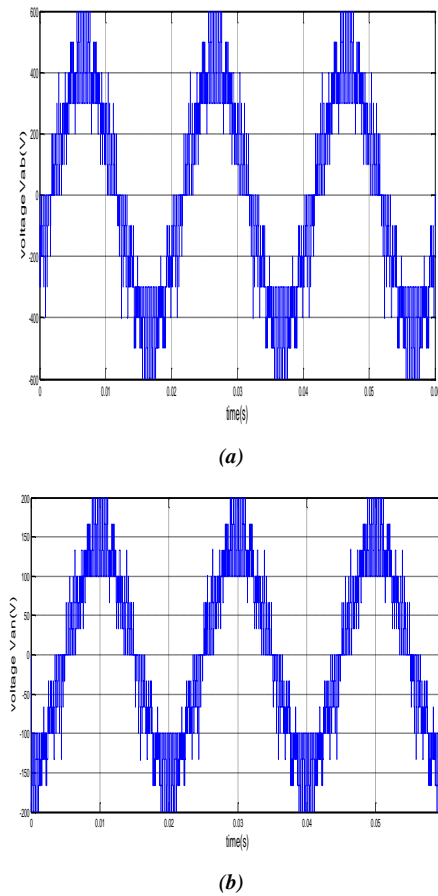

Fig. 7. The voltage results V_{ab} and V_{an} of inverter seven levels without fault.

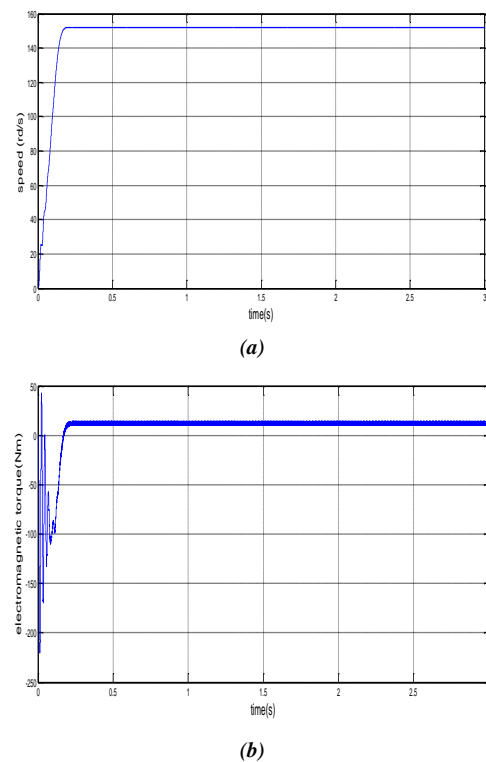
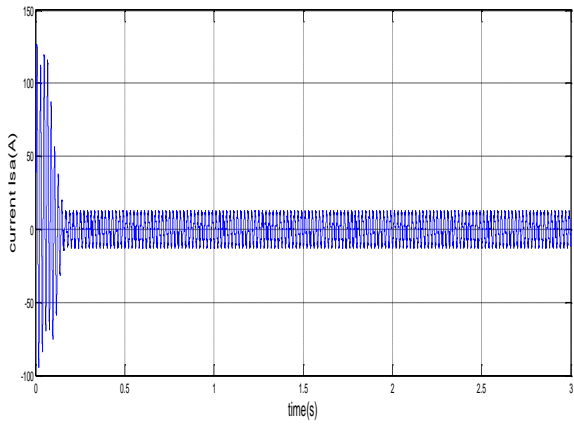
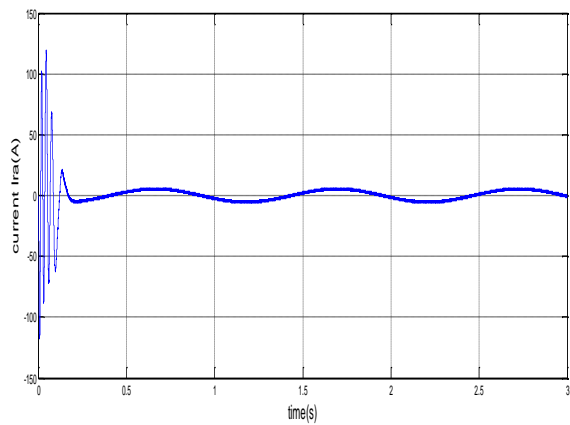

Fig. 8. Speed, electromagnetic torque results of inverter seven levels without fault



(a)



(b)

Fig. 9. The current $I_{s\alpha}$, $I_{r\alpha}$ result of inverter seven levels without fault

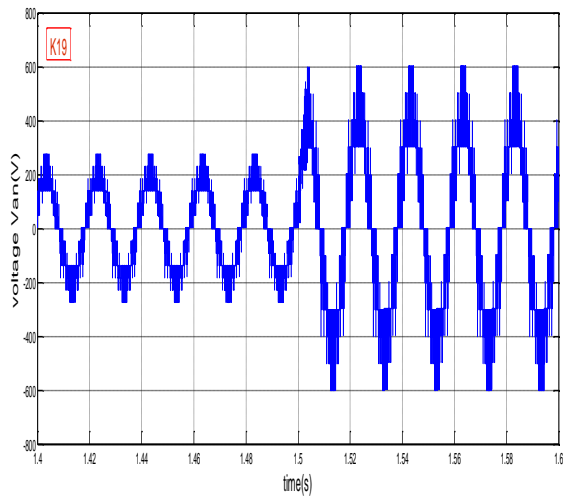
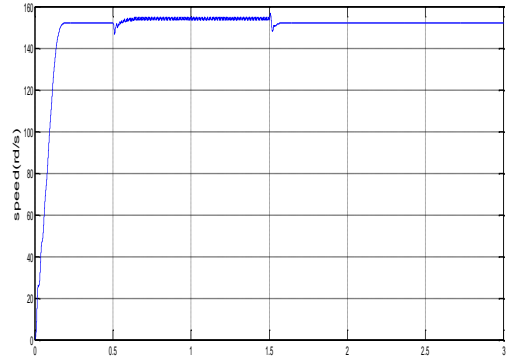
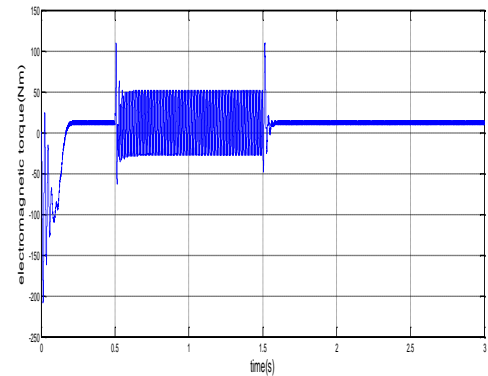

Fig.10 .The voltage results V_{an} of inverter seven levels with fault in switch K_{19} at t (1.4, 1.6)



(a)



(b)

Fig.11. Speed, electromagnetic torque results of inverter seven levels with fault in switch K_{19} at t (1.4, 1.6)

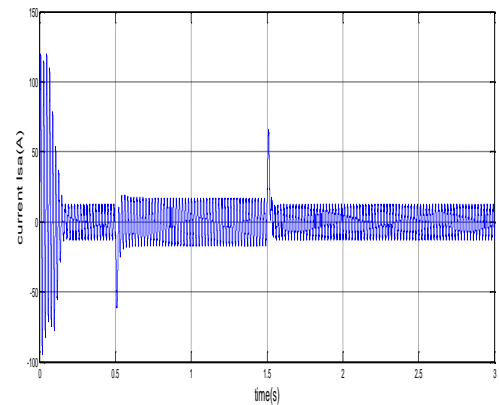

(a)

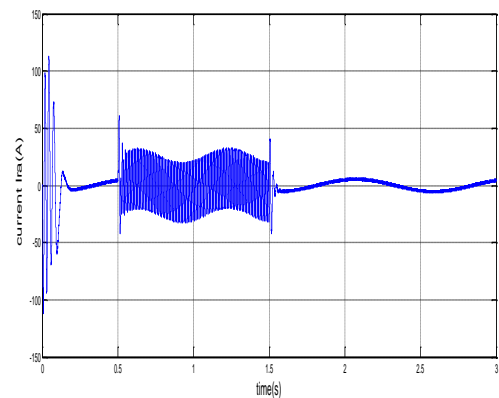

(b)

Fig. 12. the current $I_{s\alpha}$, $I_{r\alpha}$ result of inverter seven levels with fault in switch K_{19} at t (1.4, 1.6)

VI. CONCLUSION

We developed a new structure of the voltage inverters with three levels, like their principle of operation associated with an asynchronous machine, one notes according to the results obtained a clear improvement of the performances of the unit inverter machine compared to the conventional inverter. Then we elaborate a new functional model of the three-phase inverter with seven levels. The results obtained show well the contribution of the inverters multi levels for the improvement of the performances of the asynchronous machine.

After proposed the diagnosis method of fault of the inverter seven levels which proposes the following advantage, the diagnostic of fault can easily identifies each fault of commutation.

REFERENCES

- [1] G. Segurier, F. Labrique " les convertisseurs de l'électronique de puissance," volume 04. , technique et documentation-Lavoisier, 1989.
- [2] B. Ouheid, " la contribution de l'analyse des onduleurs multi niveaux", mémoire de magister, 2005.
- [3] B. Raison, "Détection et localisation de défaillances sur un entraînement électrique", Thèse de doctorat, Institut National Polytechnique de Grenoble, France, 2000.
- [4] J.N. Fiorina, "onduleurs et harmonique (cas des charges non linaires", CT édition juin 1992.
- [5] J. Sprooten, J.C Maun., "internal fault analysis of induction machines. Flux magazine", n° 43 - trimestriel - octobre 2003 - cédrat - cédrat technologies - magsoft corp.
- [6] K.Mendaz, "Développement de nouvelle méthodes numérique pour l'analyse dans la conversion des systèmes électromagnétiques de grande capacité", Mémoire de magister, université de Sidi Bel Abbes 2008.
- [7] Mendaz. K, Bounoua. H, Felliti. M, Day. Z, Diagnostic of Inverter five Levels Associated with Asynchronous Machine, International Conférence on Power electronics and their Applications ICPEA 2013, 6-7 Novembre 2013, Djelfa -Algeria.
- [8] Mendaz. K, Bounoua. H, Felliti. M, Diagnostic of inverter three Levels Associated with Asynchronous Machine, International Journal of Engineering Research and Technology IJERT, volume2, Issue9, September 2013.

BIOGRAPHIES

Kheira MENDAZ was born in Ain Temouchent, Algeria, in 1976. He received the engineer in electrical engineering from Djillali Liabes University, Sidi Bel Abbes, Algeria, in 2005, and the M.S degrees in electrical engineering from Sidi Bel Abbes University, Algeria, in 2008; His research interests include high-frequency power conversion, magnetic design, EMI reduction techniques, power electronics and EMC in power converter.

Houria BOUNOUA received the B.S degree in electrical engineering from USTO (Technology Sciences University of Oran), Algeria in 1983, the M.S. and Ph.D degrees in electrical engineering from Sidi Bel Abbes University, Algeria, in 1991 and 2004, respectively. Since 1983, she is a teaching member and involves in research on Numerical command on Power Systems, at Sidi Bel Abbes University (Algeria).

MOHAMED FELITI He received the engineer in electrical engineering from Djillali Liabes University, Sidi Bel Abbes, Algeria, in 2005, and the M.S degrees in electrical engineering from Sidi Bel Abbes University, Algeria, in 2008. His research interests include high-frequency power conversion, magnetic design, EMI reduction techniques, power electronics and EMC in power converter.

HOUSSIN MILOUDI was born in Sidi Bel Abbes, Algeria, in 1982. He received the engineer in electrical engineering from Djillali Laibes University, Sidi Bel Abbes, Algeria, in 2005, the M.S degrees in electrical engineering from Sidi Bel Abbes University, Algeria, in 2008. His main research interests are high-power converters, motor drives, and their application issues.