

Hybrid Fuzzy sliding mode performance control applied to a DFIG system for the production and integrated wind energy into a power grid based three-level converters

B. Belabbas

Abstract— In this paper we have developed a hybrid nonlinear robust control law, called fuzzy sliding mode (FSMC), which combines the advantages of both: the sliding mode (SMC) and fuzzy logic (FLC). This controller has the feature to eliminate the ripples caused by SMC; it will be applied to a doubly fed asynchronous generator to produce power from the wind. We have used the FSMC to control the active and reactive power exchanged between the stator and the grid. The two powers are decoupled by the mean of using an indirect vector control with power loop. The performance of this cascade and control are analyzed by simulation of Matlab / Simulink software.

Index Terms—Wind System, GADA, Fuzzy logic, SMC, FSMC, Vector control.

I. INTRODUCTION

WIND energy is one of the fastest growing renewable energy in the world. The generation of wind energy is clean, non-polluting, it produces no harmful was to the environment. Conventional techniques were used to adjust the wind, but assuming the wind operation in balanced conditions. Advances in technology of wind led to the design of a more powerful drive to improve their behavior and make it more robust and reliable. One of the current areas of research is the generation of electrical energy by means of double-fed asynchronous machine, using driving means such as wind power incorporated into a wind energy system, the function can DFIG on wide range of wind speed and get the maximum possible power for each wind speed. Its stator circuit is connected directly to the mains. A second circuit disposed on the rotor is connected to the network but also via power converter structure NPC three levels [1-4].

But the DFIG is subject to many constraints, such as the effects of parametric uncertainty "due to the heating, saturation "And the disturbance variable speed. These constraints could thus divert the system optimal operation [5].

B. Belabbas is with the Department of Electrical Engineering of the University of Ibn Khaldoun Tiaret, Algeria (e-mail: belabbas_1986@yahoo.fr)

This is why control should be concerned about the robustness and performance. To do this, we referred to the use of Fuzzy Sliding mode control [7-9].

Our work falls within this context and aims to control powers. It is organized as follows: Section 2 is dedicated to the modeling of the wind turbine. Then, the model and the vector control of DFIG are studied in Section 4 devoted to the development of a FSMC of DFIG, Section 5 discusses the operating principle of the rotor side converter. The system being studied is shown in Fig. 1.

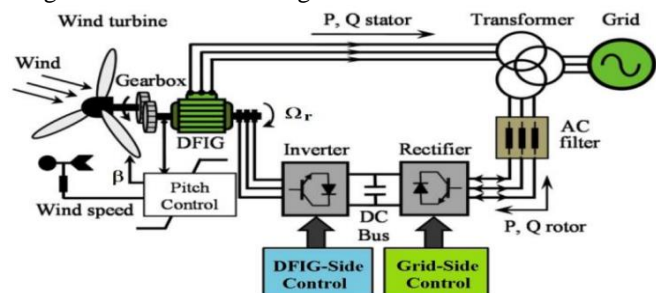

Fig.1. Diagram of a Conversion of Wind Energy.

II. MODELING OF WIND TURBINE

II.1. MODEL TURBINE

Mechanical power available on the shaft of a wind turbine is expressed by [1,5]:

$$P_{aero} = \frac{1}{2} \cdot C_p(\lambda, \beta) \cdot \rho \cdot \pi \cdot R^2 \cdot V^3 \quad (1)$$

$$\lambda = \frac{R \cdot \Omega_{mec}}{G \cdot V} \quad (2)$$

The aerodynamic torque is directly determined by [1]:

$$C_{aero} = \frac{P_{aero}}{\Omega_{Turbine}} = C_p \cdot \frac{\rho \cdot S \cdot V_1^3}{2 \cdot \Omega_{Turbine}} \quad (3)$$

The multiplier is mathematically modeled by the following equations:

$$C_g = \frac{C_{aero}}{G} \quad (4)$$

$$\Omega_{turbine} = \frac{\Omega_{mec}}{G} \quad (5)$$

The power factor $C_p(\lambda, \beta)$ represents the aerodynamic efficiency of the wind turbine. The wind turbine is a complex model, however simple mathematical models are often used aerodynamic system. The expression of power coefficient that we will use in our study is given by [1]:

$$C_p(\lambda, \beta) = 0.5176 \left(116 \frac{1}{\lambda_i} - 0.4 \beta - 5 \right) \cdot \exp\left(\frac{-21}{\lambda_i}\right) + 0.0068 \lambda_i \quad (6)$$

$$\frac{1}{\lambda_i} = \frac{1}{\lambda + 0.08 \beta} - \frac{0.035}{1 + \beta^3} \quad (7)$$

The fundamental equation of dynamics to determine the evolution of the mechanical speed from the total mechanical torque (c_{mec}) applied to the rotor:

$$J \cdot \frac{d\Omega_{mec}}{dt} = C_{mec} - C_g - C_{em} - C_{vis} \quad (8)$$

$$C_{vis} = f \cdot \Omega_{mec}$$

$$J = \frac{J_{turbine}}{G^2} + J_g$$

$$f = \frac{f_{turbine}}{G^2} + f_g$$

In this section, we present a different strategy to control the electromagnetic torque to adjust the mechanical speed to maximize the electric power generated. This principle is known as the terminology (MPPT).

We are interested in controlling the electromagnetic torque servo mechanical speed using a conventional PI controller. For this study, we assume that the electrical machine and its drive are ideal and therefore, regardless of the power generated, the electromagnetic torque is developed at all times equal to its reference value. The maximum power extraction techniques include determining the speed of the turbine, which provides maximum power generated [7].

$$\frac{d\Omega_{mec}}{dt} = \frac{1}{J} \cdot (C_g - C_{em} - f \cdot \Omega_{mec}) \quad (9)$$

$$C_{emref} = PI \cdot (\Omega_{ref} - \Omega_{mec})$$

$$\Omega_{ref} = G \cdot \Omega_{turbine ref} \quad (10)$$

$$\Omega_{turbine ref} = \frac{\lambda \cdot C_{pmax} \cdot V}{R}$$

II.2. MODEL OF DFIG

Applying the Park transformation to electrical equations DFIG [1] in the referential linked to the rotating field allows us to achieve the following electrical system of equations:

The stator and rotor equation in the referential synchronous are given by:

$$\begin{cases} V_{sd} = R_s i_{sd} + \frac{d\Phi_{sd}}{dt} - \omega_s \Phi_{sq} \\ V_{sq} = R_s i_{sq} + \frac{d\Phi_{sq}}{dt} + \omega_s \Phi_{sd} \\ V_{rd} = R_r i_{rd} + \frac{d\Phi_{rd}}{dt} - \omega_r \Phi_{rq} \\ V_{rq} = R_r i_{rq} + \frac{d\Phi_{rq}}{dt} + \omega_r \Phi_{rd} \end{cases} \quad (11)$$

$$\begin{cases} \Phi_{sd} = L_s i_{sd} + M_{sr} i_{rd} \\ \Phi_{sq} = L_s i_{sq} + M_{sr} i_{rq} \\ \Phi_{rd} = L_r i_{rd} + M_{sr} i_{sd} \\ \Phi_{rq} = L_r i_{rq} + M_{sr} i_{sq} \end{cases} \quad (12)$$

$$C_{em} = P \frac{M_{sr}}{L_s} \left(\Phi_{sq} i_{rd} - \Phi_{sd} i_{rq} \right) \quad (13)$$

II.3. POWER CONTROL

To easily control the production of electricity from wind, we will achieve an independent control of active and reactive power by the stator flux orientation. The idea is to align along the axis of the rotating frame [2-4] stator flux. We therefore: $\Phi_{sq} = 0$ and consequently $\Phi_{sd} = \Phi_s$.

This choice is not random but is justified by the fact that the machine is often coupled with a powerful network voltage and constant frequency, which leads to a finding stator flux of the machine. Neglecting the resistance of the stator windings, often accepted hypothesis for high power machines: The systems of equations (11) and (12) can be simplified as follows:

$$\begin{cases} V_{sd} = 0 \\ V_{sq} = V_s = \omega_s \Phi_s \\ V_{rd} = R_r i_{rd} + \frac{d\Phi_{rd}}{dt} - \omega_r \Phi_{rq} \\ V_{rq} = R_r i_{rq} + \frac{d\Phi_{rq}}{dt} + \omega_r \Phi_{rd} \end{cases} \quad (14)$$

$$\begin{cases} \Phi_s = L_s i_{sd} + M_{sr} i_{rd} \\ 0 = L_s i_{sq} + M_{sr} i_{rq} \\ \Phi_{rd} = L_r i_{rd} + M_{sr} i_{sd} \\ \Phi_{rq} = L_r i_{rq} + M_{sr} i_{sq} \end{cases} \quad (15)$$

$$Cem = -P \frac{Msr}{Ls} \Phi_s i_{rq} \tag{16}$$

The stator active and reactive power in the orthogonal coordinate system can be written:

$$\begin{cases} P = v_{sd} i_{sd} + v_{sq} i_{sq} \\ Q = v_{sq} i_{sd} - v_{sd} i_{sq} \end{cases} \tag{17}$$

Under the assumption of a stator flux oriented, this system of equations can be simplified as:

$$\begin{cases} P = v_s i_{sq} \\ Q = v_s i_{sd} \end{cases} \tag{18}$$

From the expressions of the stator flux, we can write:

$$\begin{cases} i_{sd} = \frac{V_s}{\omega_s L_s} - \frac{Msr}{L_s} i_{rd} \\ i_{sq} = -\frac{Msr}{L_s} i_{rq} \end{cases} \tag{19}$$

$$\begin{cases} P = -\frac{V_s Msr}{L_s} i_{rq} \\ Q = -\frac{V_s Msr}{L_s} i_{rd} + \frac{V_s^2}{L_s \omega_s} \end{cases} \tag{20}$$

$$\begin{cases} \Phi_{rd} = \left(L_r - \frac{Msr^2}{L_s} \right) i_{rd} + \frac{Msr V_s}{\omega_s L_s} \\ \Phi_{rq} = \left(L_r - \frac{Msr^2}{L_s} \right) i_{rq} \end{cases} \tag{21}$$

By introducing these expressions in the equations of the rotor voltages are found:

$$\begin{cases} V_{rd} = R_r i_{rd} + \left(L_r - \frac{Msr^2}{L_s} \right) \frac{di_{rd}}{dt} - g \omega_s \left(L_r - \frac{Msr^2}{L_s} \right) i_{rq} \\ V_{rq} = R_r i_{rq} + \left(L_r - \frac{Msr^2}{L_s} \right) \frac{di_{rq}}{dt} + g \omega_s \left(L_r - \frac{Msr^2}{L_s} \right) i_{rd} + g \frac{Msr V_s}{L_s} \end{cases} \tag{22}$$

III. INDIRECT CONTROLS WITH POWER LOOP

It is based on the equations governing the operation of the machine defined in the preceding paragraph, while keeping the same assumptions.

By combining the different flow equations, the rotor voltages, currents and powers, we can write the equations of the rotor voltage depending on the power. Thus power from

the stator as a function of the rotor currents and voltages of the rotor in terms of the rotor current function [1]:

From the control unit we can develop a structure ensures good stability of the network, so we have a control unit consists of two subsystems. The first calculates the reference currents from the references (active and reactive powers), the second calculates the reference voltage from the rotor currents calculated by the first. In this spirit, we have used SMC to the inner loop (current loop) and classic PI outer loop to controlling powers. It then sets the control system given by the figure (2).

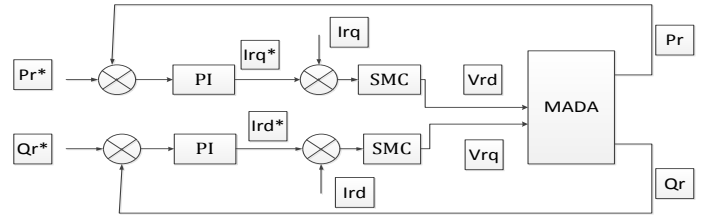

Fig.2. Block diagram of indirect control with loop power controlled by SMC.

IV. DEVELOPING OF THE HYBRID CONTROL

IV.1. INDIRECT CONTROL OF THE DFIG WITH LOOP POWER

The basic idea of the SMC is primarily attracting states of the system in a suitably selected, and then designs a control law that will always keep the system in this region [1] region. In summary SMC is divided into three parts: [1-6].

IV.1.1. CHOICE OF SWITCHING SURFACE

For a non-linear system shown in the following form:

$$\begin{aligned} \dot{X} &= f(X, t) + g(X, t) u(X, t); \\ X &\in R^n, u \in R. \end{aligned} \tag{23}$$

There $f(X, t)$, $g(X, t)$ are two continuous and uncertain nonlinear functions, assumed bounded. It takes the form of general equation proposed by J.J. Slotine to determine the sliding surface given by Slotine and all [7-9]:

$$S(X) = \left(\frac{d}{dt} + \lambda \right)^{n-1} .e \quad et \quad e = X^d - X \tag{24}$$

With, e : error on the controlled variable, λ : positive coefficient, n : order system, X^d : desired size, X : state variable of the controlled variable.

IV.1.2. CONVERGENCE CONDITION

The convergence condition is defined by the Lyapunov equation (Lopez et al, 2006), it makes the area attractive and invariant $S(X). \dot{S}(X) \leq 0$.

IV.1.3. CONTROL CALCULATION

The control algorithm is defined by the relation $u = u^{eq} + u^n$ et $u^n = u^{max} \cdot sign(S(X))$

With: u : control variable, u^{eq} : size equivalent command, u^n : term control switch, $sign(S(X))$: sign function.

IV.2. CONTROL OF ROTOR CURRENT NEXT AXIS "D"

To control the rotor current is taken $n = 1$, the expression of the current control surface along the axis "d" of the marker to form Park $S(I_{rd}) = (I_{rd}^* - I_{rd})$

Deriving the surface with the replacement of the current expression I_{rd} , obtained:

$$\dot{S}(I_{rd}) = (\dot{I}_{rd}^* - \frac{1}{\sigma \cdot L_r} (V_{rd} - R_r \cdot I_{rd})) \tag{25}$$

The control voltage V_{rd} is defined by: $V_{rd} = V_{rd}^{eq} + V_{rd}^n$
 During the sliding mode and steady state was: $\dot{S}(I_{rd}) = 0$; $S(I_{rd}) = 0$; $V_{rd}^n = 0$; or of pulling:

$V_{rd}^{eq} = \sigma \cdot L_r \cdot \dot{I}_{rd}^* + R_r \cdot I_{rd}^*$ During the convergence mode, the condition $S(X) \cdot \dot{S}(X) \leq 0$ should be checked with: $V_{rd}^n = K \cdot V_{rd} \cdot sign(S(I_{rd}))$ et $K \cdot V_{rd}$ positive gain.

IV.3. CONTROL OF ROTOR CURRENT NEXT AXIS "Q"

To control the rotor current is taken $n = 1$, the expression of the current control surface along the axis "q" of the marker to form Park $S(I_{rq}) = (I_{rq}^* - I_{rq})$

Deriving the surface with the replacement of the current expression I_{rq} , on gets:

$$\dot{S}(I_{rq}) = (\dot{I}_{rq}^* - \frac{1}{\sigma \cdot L_r} (V_{rq} - R_r \cdot I_{rq})) \tag{26}$$

The control voltage V_{rq} is defined by: $V_{rq} = V_{rq}^{eq} + V_{rq}^n$
 During the sliding mode and steady state was: $\dot{S}(I_{rq}) = 0$; $S(I_{rq}) = 0$; $V_{rq}^n = 0$; or of pulling:

$V_{rq}^{eq} = \sigma \cdot L_r \cdot \dot{I}_{rq}^* + R_r \cdot I_{rq}^*$ During the convergence mode, the condition $S(X) \cdot \dot{S}(X) \leq 0$ should be checked with: $V_{rq}^n = K \cdot V_{rq} \cdot sign(S(I_{rq}))$ et $K \cdot V_{rq}$ positive gain.

V. FUZZY SLIDING MODE CONTROL OF INTERNAL LOOP DFIG

The disadvantage of the SMC is that the term switching control where we have lot of ripples. To reduce it, we replace

it by a fuzzy structure (Wong et al, 2001). FSMC, which is designed to control the rotor current, is shown in Fig.3 [9-16].

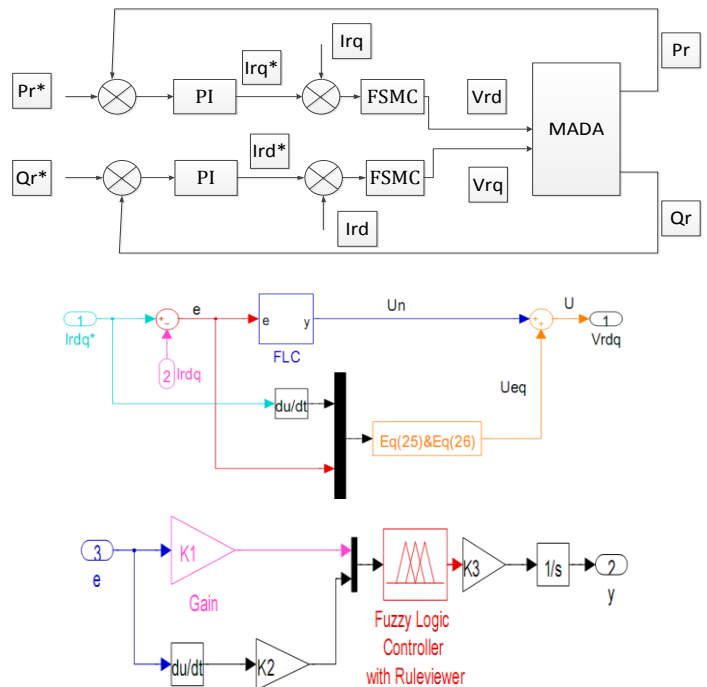

Fig.3. Block diagram of indirect control with loop controlled power FSMC.

The fuzzy logic control is expanding. Indeed, this method provides a very effective law often set without doing extensive modeling. As opposed to a standard regulator or a regulator of state-reaction against the controller fuzzy logic does not address a well-defined mathematical relationship, but uses inferences with multiple rules, based on linguistic variables. By inference with several rules, it is possible to take account of experience gained by the operators of a technical process.

Three linguistic variables input-output are shown in Fig.4. The fuzzy rules can be written as shown in Table 1. For this purpose, it is used a system of Mamdani-type fuzzy logic. The member ship function resulting from the aggregation of using the operator max. The Defuzzification of the output control is accomplished using the method of center of gravity [5-7-9].

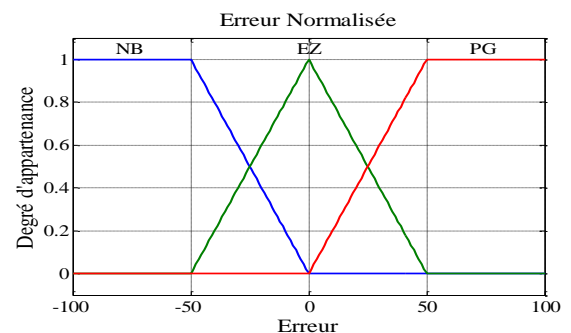

Fig.4. Membership functions of the different linguistic variables.

TABLE1. Rules for RFL.

E_X	NP	EZ	PG
ΔE_X			
NP	NP	NP	EZ
EZ	NP	EZ	PG
PG	EZ	PG	PG

VI. MODELING AND CONTROL OF THE THREE LEVELS STRUCTURE NPC VSI

VI.1. THE THREE-LEVEL NPC VSI STRUCTURE

The three phases three-level NPC VSI is constituted by three arms and two DC voltage sources. Every arm has four bi-directional switches in series and two diodes (Fig. 5) [2].

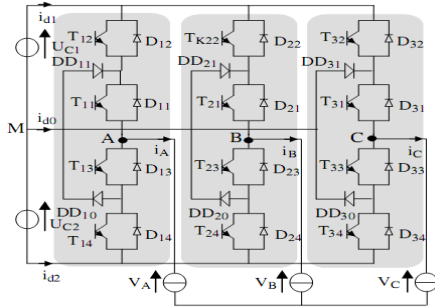

Fig.5. The three-level NPC inverter.

VI.2. KNOWLEDGE MODEL

The switch connection function F_{ks} indicates the opened or closed state of the switch T_{ks} .

We define to a half arm connection function F_{km}^b with:
K: Arm number.

$$m = \begin{cases} 1 & \text{for the lower half arm} \\ 0 & \text{for the upper half arm} \end{cases}$$

For an arm k of the three-phase three-level NPC VSI, several complementary laws controls are possible. The control law which lets an optimal control of this inverter is [3]:

$$\begin{cases} B_{k1} = \bar{B}_{k4} \\ B_{k2} = \bar{B}_{k3} \end{cases} \quad (27)$$

Where B_{ks} represents the gate control of the switch T_{ks} .

We define the half arm connection function F_{11}^b and F_{10}^b associated respectively to the upper and lower half arms.

Where i is arm number $i \in \{1,2,3\}$

$$\begin{cases} F_{11} = 1 - F_{14} & F_{21} = 1 - F_{24} & F_{31} = 1 - F_{34} \\ F_{12} = 1 - F_{13} & F_{22} = 1 - F_{23} & F_{32} = 1 - F_{33} \end{cases} \quad (28)$$

The output voltages of the inverter relatively to the middle point M are defined as follows:

$$\begin{bmatrix} V_{AM} \\ V_{BM} \\ V_{CM} \end{bmatrix} = \begin{bmatrix} F_{11}^b \\ F_{21}^b \\ F_{31}^b \end{bmatrix} \cdot U_{c1} - \begin{bmatrix} F_{10}^b \\ F_{20}^b \\ F_{30}^b \end{bmatrix} \cdot U_{c2} \quad (29)$$

The system (29) shows that the three-level NPC VSI can be considered as two two-level voltage source inverters in series. The input currents of the inverter are given as follow:

$$\begin{cases} i_{d1} = F_{11}^b \cdot i_1 + F_{21}^b \cdot i_2 + F_{31}^b \cdot i_3 \\ i_{d2} = F_{10}^b \cdot i_1 + F_{20}^b \cdot i_2 + F_{30}^b \cdot i_3 \end{cases} \quad (30)$$

The current i_{d0} is defined by the following relation:

$$i_{d0} = F_{11} \cdot F_{13} \cdot i_1 + F_{21} \cdot F_{23} \cdot i_2 + F_{31} \cdot F_{33} \cdot i_3 \quad (31)$$

VI.3. PWM STRATEGY OF THE THREE-LEVEL NPC VSI

The inverter is controlled by the space vector modulation strategy which uses two bipolar carriers. This strategy is characterized by two parameters:

Modulation index m defined as ratio between the carrier frequency f_p and the reference voltage frequency:

$$m = \frac{f_p}{f} \quad (32)$$

Modulation rate r is the ratio between the magnitudes V_m of the reference voltage and three times of the carriers magnitude U_{pm} :

$$r = \frac{V_r}{V_p} \leq 1 \quad (33)$$

VII. CASCADE (RECTIFIER, FILTER AND INVERTER) WITH DFIG

In this part of the chapter, the dynamic behavior of the wind turbine based on doubly fed machine (DFIG) connected to the network is studied. The stator of the DFIG is directly connected to the network, against the rotor is connected to it via a cascade (rectifier, filter and inverter). This changer allows indirect frequency from a fixed network frequency and amplitude has a system output voltage frequency and variable amplitude.

The general structure of this cascade is shown in Fig.6. The rectifier and inverter are controlled by the two sinusoidal carrier strategy triangular saw tooth.

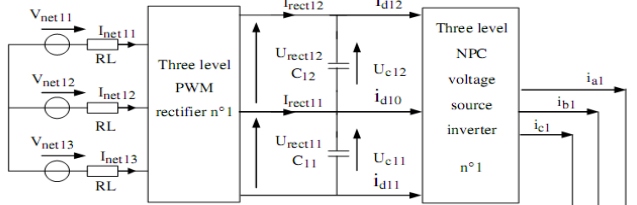

Fig.6. Cascade of a turbine, a rectifier - inverter voltage three-phase three-level feeding the DFIG.

VII.1. MODELLING OF THE INTERMEDIATE FILTER

The model of the intermediate filter is defined by the following system:

$$\begin{cases} U_{C1} = \frac{1}{C_1} \int (I_{rect1} - I_{d1}) dt \\ U_{C2} = \frac{1}{C_2} \int (I_{rect2} - I_{d2}) dt \end{cases} \begin{cases} C_1 \cdot \frac{dU_{C1}}{dt} = I_{rect1} - I_{d1} \\ C_2 \cdot \frac{dU_{C2}}{dt} = I_{rect2} - I_{d2} \end{cases} \quad (34)$$

VIII. THE HALF CLAMPING BRIDGE

To improve the input voltages of the three-level NPC inverter, we propose to use a half clamping bridge, constituted by a transistor and a resistor [3]. The transistors are controlled to maintain equal the different input DC voltages of the inverter (Fig. 7).

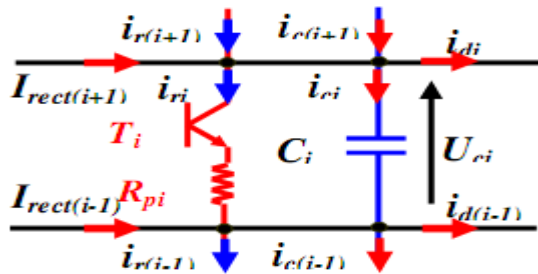

Fig.7. Structure Bridge clamping with intermediate filter.

VIII.1. MODELLING OF THE INTERMEDIATE FILTER

Figure 8 shows the structure of the intermediate filter of the studied cascade.

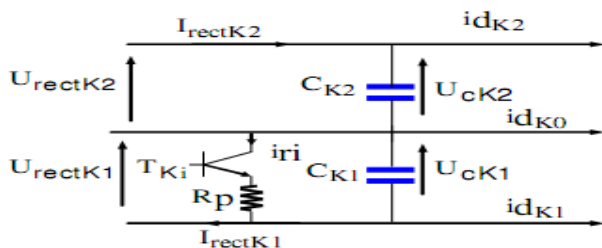

Fig.8. Structure of the intermediate filter of the half clamping bridge cascade.

The model of the half clamping bridge-filter set is defined by the following equation:

$$\begin{cases} U_{C1} = \frac{1}{C_1} \int (I_{rect1} - I_{r1} - I_{d1}) dt \\ U_{C2} = \frac{1}{C_2} \int (-I_{rect2} - I_{r2} + I_{d2}) dt \end{cases} \quad (35)$$

$$I_{ri} = T_i \cdot \frac{U_{Ci}}{R_{pi}} \quad \text{Avec } i = \{1, 2\} \quad (36)$$

The control algorithm of the resistive clamping circuits can be summarized as follows:

$$\begin{cases} (U_{Ci} - U_{ref}) = \varepsilon_i \\ \text{if } \varepsilon_i > 0 \text{ Then } T_i = 1 \Rightarrow I_{ri} = T_i \cdot \frac{U_{Ci}}{R_{pi}} \\ \text{if } \text{NOT } T_i = 0 \Rightarrow I_{ri} = 0 \end{cases} \quad (37)$$

VIII.2. VOLTAGE LOOP MODEL

The modeling of this loop is based on principle of instantaneous power conservation with no loss hypothesis. This boucle imposes efficacy network reference current. The input power is calculated as:

$$P_e = \sum_{K=1}^3 \left(V_{netK} \cdot i_{netK} - R_{net} \cdot i_{netK}^2 - \frac{L_{net}}{2} \frac{di_{netK}^2}{dt} \right) \quad (38)$$

The output power is calculated as:

$$P_e = U_{C1} \cdot (i_{C1} + i_{load1}) + U_{C2} \cdot (i_{C2} + i_{load2}) = U_{rect1} \cdot I_{rect1} - U_{rect2} \cdot I_{rect2} \quad (39)$$

It is assumed that the following: $U_{C1} = U_{C2} = U_C$ and $C_1 = C_2 = C$.

Define variables. i_c, i_{load} and U_C

$$\begin{cases} i_c = \frac{i_{C1} + i_{C2}}{2} \\ i_{Ch} = \frac{i_{d1inv} - i_{d2inv}}{2} \\ U_C = U_{Cmoy} = \frac{U_{C1} + U_{C2}}{2} \\ i_{rec} = i_c + i_{load} \end{cases} \quad (40)$$

Using the principle of conservation of power and neglecting the Joule losses in the resistance Rnetw, we can write:

$$\sum_{K=1}^3 (V_{netK} \cdot i_{netK}) = \sum_{K=1}^3 \frac{L_{netK}}{2} \frac{di_{netK}^2}{dt} + 2 \cdot U_C \cdot (i_c + i_{Laod}) \quad (41)$$

$$3 \cdot V_{eff} \cdot I_{eff} = 2 \cdot U_C \cdot (i_c + i_{load}) \quad (42)$$

Where E_{eff} is the rms value of grid voltages and I_e is the rms value of grid currents. U_c is the constant value of the DC capacitor voltage and I_{rect} is the DC current. A IP regulator is used to regulate the DC voltage. The general principle feedback of three-level rectifier is shown on Fig.9.

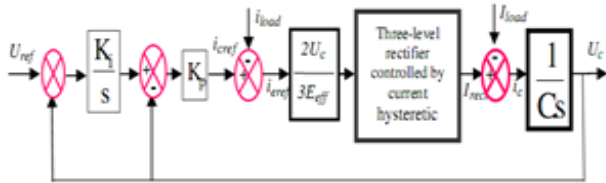

Fig.9. Enslavement algorithm of output voltage of three-level rectifier.

IX. SIMULATION RESULTS

In this section, we present the work on the modeling of a chain of wind conversion based on an asynchronous machine is comprised of dual power controlled by the technique of PWM rectifier and a DC bus, all connected to the network via a PWM inverter and a filter. Modeling the overall wind conversion chain and the associated control device are developed in the form of an equivalent continuous model which takes into account the relevant components of the currents and voltages at the machine, and the DC bus network.

We applied a control algorithm on the voltages (U_{c1} , U_{c2}) with the aim of stabilizing the past to balance the midpoint M.

The strategy of indirect control based controllers SMC and FSMC rotor currents of DFIG were implemented in MATLAB environment to perform tests of control.

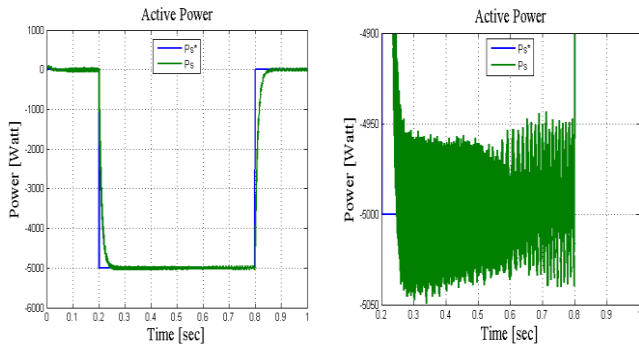

Fig.10. Active power graphics of DFIG with indirect vector control with loop power controlled by FSMC.

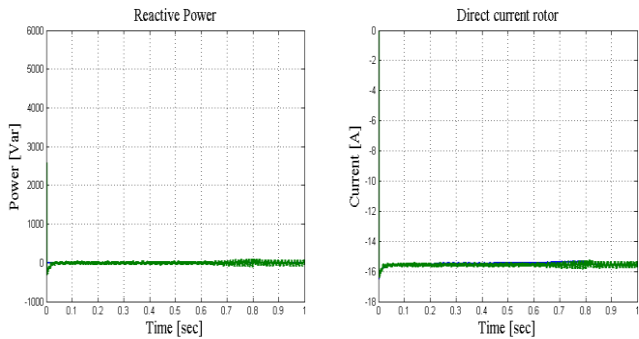

Fig.11. Power & currents graphics.

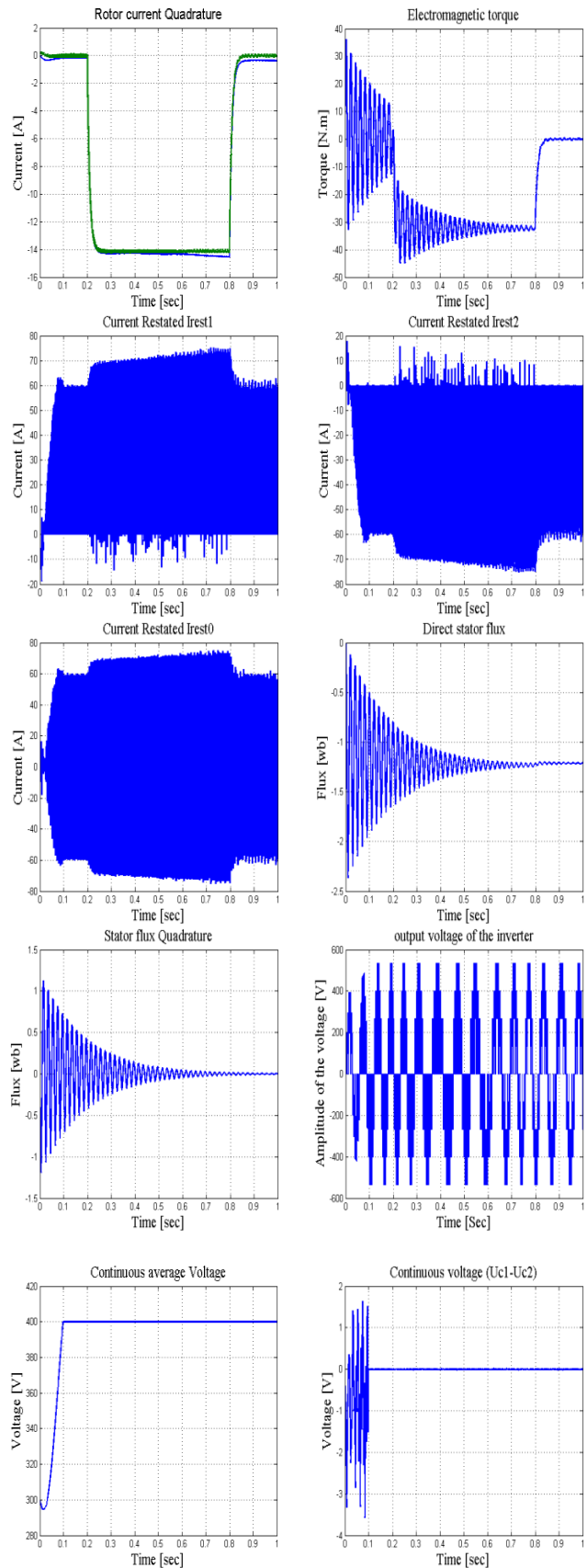

Fig.12. Current, voltage, flux, torque variations of the system.

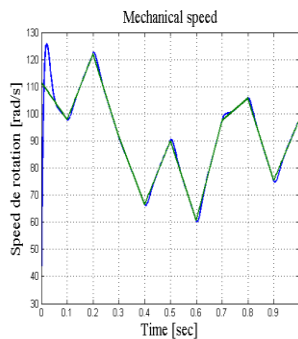

Fig. 13. Behavior of the powers of DFIG with indirect vector control with loop power controlled by FSMC.

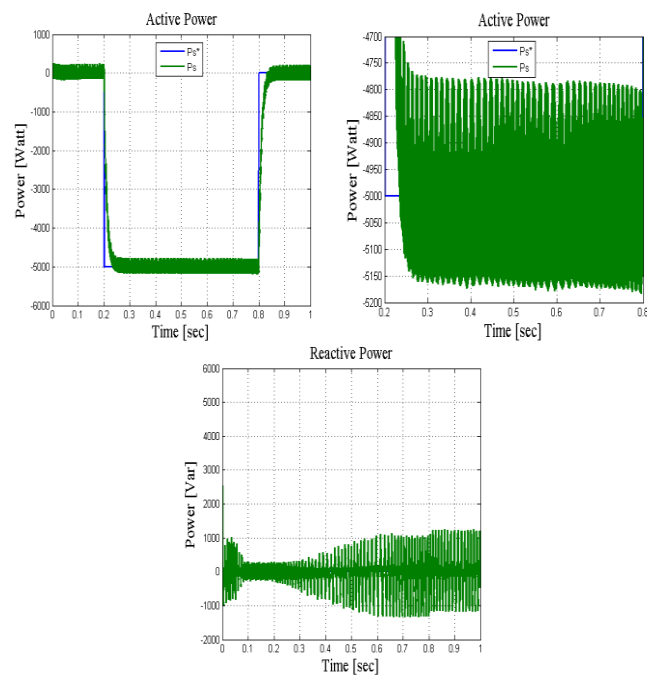

Fig. 14. Active and reactive power variations of the system.

The simulation results show different curves are obtained by controlling the active and reactive power generated at the stator of the DFIG. This control technique allows you to decouple the expressions of active and reactive power of the generator or in the flux and torque.

According to the results, we find that the indirect control with loop power controller using SMC or FSMC have good decoupling control of active and reactive power at the stator. After a transitional period, the parameters perfectly follow their reference.

The reactive power is zero and it is a condition of operation of the DFIG for a unity power factor.

As we reported earlier that the disadvantage of the SMC is the ripples. To reduce it, we combined this control with fuzzy logic to build a new structure called FSMC, which allows reducing the chattering phenomena of over 75% in our study.

We can see that the stator flux follows the following reference axis (d) with almost zero quadrature components, which means that the decoupling of the machine is successful.

It is clear that the quadrature component of the rotor current I_{rq} control the electromagnetic torque so the active power. The direct component of the rotor current, and thus control the flow of reactive power transmitted between the stator and the network. This is found in the changes in direct and quadrature components of rotor currents, which are the images of active and reactive powers.

Note that the electromagnetic torque reacts spontaneously when there is a demand for active power, reactive power independently

We observe that the current I_{rest1} presents a look opposite to that of I_{rest2} . This is necessary for the current I_{rest0} has a zero mean value. As can be seen, the current I_{rest0} is substantially zero mean value.

Note that the two DC voltages well below their reference and we also find that the difference between the two voltages is practically zero after a transient 0.1s which mean a better stability of the midpoint.

X. CONCLUSION

This study has allowed us to study the modeling of a chain of wind conversion based on DFIG consists of a rectifier control by the PWM technique, and a DC bus, all connected to the network via a PWM inverter and a filter.

We studied the indirect vector control loop power DFIG which allows a decoupling between the flux and torque.

The control is provided by two orders SMC and FSMC for which we found the performance of the latter relative to the SMC perspective chattering.

REFERENCES

- [1] M. Adjoudj et al, "Sliding mode control of a doubly fed induction generator for wind turbines", conversion systems. Rev. Roum. Sci. Techn. – Électrotechn. et Énerg., Vol.56, No.1, 2011, pp.15-24.
- [2] R. Manavalan, C.S. Kumar, "Analysis of Hybrid Renewable Energy System using NPC Inverter", Research Inveny: International Journal of Engineering and Science, Vol.2, No.7, March 2013, pp. 26-30.
- [3] G. Abad J. Lopez, M.A. Rodriguez, L. Marroyo, G. Iwanski, "Doubly fed induction machine: modeling and control for wind energy generation", IEEE press Series on Power Engineering, Aug 2011.
- [4] F. Poitiers, M. Machmoum, R.L. Doeuff and M.E. Zaim, "Control of a doubly-fed induction generator for wind energy conversion system", Australasian Universities Power Engineering Conference AUPEC 2009, Australia.
- [5] M. Hilal, Y. Errami, M. Benchagra and M. Maaroufi "Fuzzy Power Control For Doubly Fed Induction Generator Based Wind Farm," Journal of Theoretical and Applied Information Technology, 30th September 2012, Vol. 43 No.2, pp.321-330.
- [6] F. Valenciaga, C.A. Evangelista "Sliding active and reactive power control of a wind energy conversion system", IET Control Theory and Applications, Vol.4, No.11, 2010, pp.2479-2490.
- [7] R. Palm, "Sliding mode fuzzy control," Fuzzy Systems, IEEE conference proceeding, Vol.2, 2002, pp. 1393-1398.
- [8] S. Aezki, M. Boudour, "Contribution to the improvement of the performances of a chain of conversion of energy fed by a double source", 2nd International Conference on Advances in Energy Engineering (ICAEE 2011), December 2011, Bangkok, Thailand.
- [9] F. Piltan, N. Sulaiman, S. Roosta, A. Gavahian, S. Soltani, "Artificial Chattering Free on-line Fuzzy Sliding Mode Algorithm for Uncertain System: Applied in Robot Manipulator, International Journal of Engineering, Vol.5, No.5, 2011, pp.360-379.

- [10]L. Xu and P. Cartwright, "Direct Active and Reactive Power Control of DFIG for Wind Energy Generator", IEEE Transactions on Energy Conversion, Vol.21, No.3, September 2006, pp. 750–758.

BIOGRAPHIES



Belabbas Belkacem was born in Tiaret in Algeria in 1986. In 2009 he received the qualification status in electrical engineering at the University of Ibn Khaldoun Tiaret, Algeria, and in 2012 he was awarded the Magister degree in electrical engineering from the University of Ibn Khaldoun Tiaret-Algeria-. Participate in some international conferences in Algeria. His research focuses on the integration and management of renewable energy into the grid.