



THE THERMAL EFFECTIVENESS COMPARISON OF THE CLASSICAL AND FINNED SOLAR SYSTEMS

Mustafa AKTAŞ, İlhan CEYLAN*, Hikmet DOĞAN

*Mechanical Education Department, Technical Education Faculty, Gazi University,
Teknikokullar, 06503 Ankara, ilhancey@gmail.com

(Geliş Tarihi: 28. 07. 2006)

Abstract: In this study, experimental analysis of optimum fin size, which can be used in heat exchanger in solar energy systems, has been performed. For this purpose, two systems, one of which is classic and the other finned, were designed and manufactured. According to the experimental tests, which lasted for six days, the system with a fin is 7% more efficient than the classical system. Therefore, it has been concluded that it is useful to use fins in solar energy systems with a suitable sizing.

Keywords: Solar energy, Fin, Domestic hot water, Optimum fin dimension.

GÜNEŞ ENERJİLİ KLASİK VE KANATÇIKLI SİSTEMLERİN ISIL VERİMİNİN KARŞILAŞTIRILMASI

Özet: Bu çalışmada, güneş enerjisi sistemlerinde ısı değiştiricilerde kullanılabilecek optimum kanatçık boyutunun deneysel analizi yapılmıştır. Bu amaç için biri klasik ve diğeri de kanatçıklı olmak üzere iki sistem tasarlanıp, imal edilmiştir. Altı gün süreyle yapılan deney sonuçlarına göre kanatçıklı sistemin klasik sisteme göre ısıl bakımdan %7 daha verimli olduğu tespit edilmiştir. Böylece; uygun bir boyutlandırma ile güneş enerjisi sistemlerinde kanatçık kullanımının faydalı olacağı sonucuna varılmıştır.

Anahtar kelimeler: Güneş enerjisi, Kanatçık, Sıcak su, Optimum kanatçık boyutu.

NOMENCLATURE

A	The surface area of the heat exchanger [m ²]
A _c	Fin cross section area [m ²]
β ₁	Volume expansion number [K ⁻¹]
β	The angle of the solar collector and the horizontal plane [25°]
F _k	The surface area of the collector [m ²]
g	Gravitational acceleration [ms ⁻²]
Gr	Grashof number
h	Heat convection coefficient [Wm ⁻² K ⁻¹]
I _{DIR}	Direct radiation [Wm ⁻² day ⁻¹]
I _{DIF}	Diffuse radiation [Wm ⁻² day ⁻¹]
I _{TOT}	The energy gained from the total radiation striking the collector surface [Wm ⁻² day ⁻¹]
k	Heat conduction coefficient, [Wm ⁻¹ K ⁻¹]
L	Fin height [m]
\dot{m}	Mass flow rate of water [kgday ⁻¹]
n	The number of the day, starting from the January 1 st
Nu	Nusselt number
P	Fin perimeter [m]
Pr	Prandtl number
q _f	Heat amount passing the fin [Wm ⁻²]
\dot{Q}	The total energy amount stored [kJ day ⁻¹]
Ra	Rayleigh Number

r _a	The reflection coefficient for the total solar radiation of the inclined plane perimeter ≈ 0.2
T _y	Surface temperature [K]
T _∞	Fluid temperature [K]
T _{∞,1}	The fluid temperature in the heat exchanger [K]
t	Fin thickness [m]
v	Average radiation values before atmosphere for the experiment months [Wm ⁻² day ⁻¹]
ν	Kinematic viscosity [m ² s ⁻¹]
w	Fin length [m]
θ _b	Temperature difference, [K]
ε	Opacity factor
φ	The average horizontal surface radiation value for the experiment day [Wm ⁻² day ⁻¹]
δ	Declination angle
φ	Latitude degree
γ	Azimuth angle
ω	Hour angle

INTRODUCTION

Due to the recently rising energy costs and negative environmental factors, the solar energy has become much more important as a renewable source of energy. For example, the utilization of the solar energy reduces the amount of CO₂ emission of a single house as 750 kg

per year (Viesmann, 1997). The solar energy is utilized and used in many different thermal applications, such as production of domestic hot water, drying of products, heating for local residences and greenhouses, solar pools, water purification systems, salt production, refrigeration systems, solar ovens, solar pumps, electricity production, etc.

Solar energy driven domestic hot water preparation systems are arranged as direct or indirect circuits depending on the circuit formation, and as gravity or pumping flow systems depending the circulation systems. Application of a certain system is related to numbers of factors, such as; meteorological conditions of the region, the amount of hot water required, architectural structure, hygienic installation of the structure, collector surface size, the location of the structure, and the characteristics of water in the system.

In this study, optimum fin dimensions to be used in heat exchanger for solar energy driven domestic hot water preparation systems are examined. Two different systems, one of which is classical and the other one is with the optimum fin size, were designed and manufactured. The performances of both systems were experimented and then results were examined in detail.

THEORETICAL ANALYSIS

One of the necessities for increasing the amount of heat transfer in the heat exchanger used in solar energy systems is to utilize the optimum fin both in dimension and in characteristics. However, in practice, the usage of fin in the system may not be suitable in all cases. Thus, one cannot claim that the use of fin will always increase the heat transfer. The “**fin effectiveness (ϵ_f)**” is defined as the ratio of finned heat transfer to the no fin heat transfer. In design, the value of fin effectiveness should be as great as possible. In general, the usage of fin is not suitable unless fin effectiveness is $\epsilon_f \geq 2$. In case the “ $\epsilon_f \geq 2$ ” to be used as a criterion to justify the performance of the value of fin effectiveness, then the “ $(kP/hA_c) > 4$ ” should be maintained. The formula of the fin effectiveness is given at Equation 1 (Incropera and Dewitt, 1996).

$$\epsilon_f = \frac{q_f}{h A_c \theta_b} \quad (1)$$

There are four boundary conditions in the fin analysis: the heat convection, adiabatics, a definite temperature and infinite fins. For one of these boundary conditions, the fin effectiveness with fixed cross-sectional area is seen in Equation 1; this can be obtained by the division of the heat transfer with $(q_f) h A_c \theta_b$. The placement order of the fins can change the heat convection coefficient, but this effect is generally ignored. Thus, the fact that the heat convection coefficient of the finned surface is regarded as equal to the finless surface gives the result in Equation 2 for infinite fin approach.

$$\epsilon_f = \frac{k P}{h A_c} \quad (2)$$

The upper boundary is determined for “ ϵ_f ” in Eq. (2) and this boundary is being approached while the value of “ L ” moving to infinite. However, the usage of long fins is not essential for acquiring the maximum output in the heat transfer. Eq. (3) shows that, 98 % of the heat transfer caused by the fins may occur when $m \times L = 2 \times 3$ is provided when the adiabatic extreme boundary conditions are concerned. Thus it is pointless for the fins being longer than $L = 2 \times 3/m$.

$$q_f = \sqrt{h P k A_c} \theta_b \tanh m L \quad (3)$$

When the fin is used in solar energy systems, the boundary condition is heat convection through the transportation from the fin tip to the fluid.

The coefficient “ m ” given in Eq. (3) is given with Eq. (4).

$$m^2 = \frac{h P}{k A_c} \quad (4)$$

The flow movement is divided as natural heat convection and forced heat convection due to the factors that cause flowing. The heat convection coefficient is based on various factors; namely, the kind of flow, laminar and turbulent flow, whether the flow is active, the geometrical relation of the surface and the flow, thermal and the thermo physical feature of the flow. Thus the heat convection coefficient is determined experimentally, except for some basis geometries. In horizontal cylinders or tubes, the external diameter of the tube is taken as the characteristic number in the Grashof and Rayleigh numbers. In a horizontal tube, the approximate Nusselt number is given in Eq. (5) (Halıcı and Gündüz, 2001).

$$Nu = \frac{h D}{k} = C Ra^n \quad (5)$$

“ C ” and “ n ” coefficients are given in the Table 1 based on the “ Ra ” number, which is given in the Eq. (5). The Rayleigh and Grashof number for the horizontal tube used in the system of natural heat convection conditions is given in Eqs. (6) and (7) (Kakaç, 1987).

$$Ra = Gr Pr \quad (6)$$

$$Gr = \frac{D^3 \beta_1 g \Delta T}{\nu^2} \quad (7)$$

The volume expansion number is given in Eq. (8).

$$\beta_1 = \frac{1}{T_f} \quad (8)$$

Table 1. Constant proportions that are based on the Rayleigh number (Öz *et al.*, 2004).

Ra	C	n
$10^{-10} - 10^{-2}$	0.675	0.058
$10^{-2} - 10^2$	1.020	0.148
$10^2 - 10^4$	0.850	0.188
$10^4 - 10^7$	0.480	0.250
$10^7 - 10^{12}$	0.125	0.333

T_f given with Eq. (8) (expressed as Kelvin) may be calculated by $(T_y + T_\infty) / 2$. During the experiment, $T_y + 2 = T_{\infty,1}$ is measured (Aktaş, 2003). The heat transfer amount of the heat exchanger surface is given with Eq. (9).

$$Q = h A (T_y - T_\infty) \quad (9)$$

Equation 10 was used in order to calculate the energy amount crossing through the sun to the collector (Reddy, 1987).

$$I_{TOT} = [I_{DIR} R] + I_{DIF} \left[\frac{1 + \cos \beta}{2} \right] + [I_{DIR} + I_{DIF}] r_a \left[\frac{1 - \cos \beta}{2} \right] \quad (10)$$

Unknown values in Eq. (10) were calculated with the help of the following equations.

Direct radiation value (Aktaş, 2003),

$$I_{DIR} = \phi - I_{DIF} \quad (11)$$

Diffusion radiation value,

$$I_{DIF} = [1 - (1.097 \varepsilon)] \phi \quad (12)$$

Opacity factor,

$$\varepsilon = \frac{\phi}{\nu} \quad (13)$$

$$R = \frac{\cos \theta}{\cos \theta_2} \quad (14)$$

$$\cos \theta = [\sin \delta \sin \phi \cos \beta] - [\sin \delta \cos \phi \sin \beta \cos \gamma] + [\cos \delta \cos \phi \cos \beta \cos \omega] + [\cos \delta \sin \phi \sin \beta \cos \gamma \cos \omega] + [\cos \delta \sin \beta \sin \gamma \sin \omega] \quad (15)$$

$$\cos \theta_2 = [\sin \phi \sin \delta] + [\cos \phi \cos \delta \cos \omega] \quad (16)$$

Declination angle (Uyarel and Öz, 1987),

$$\delta = 23.45 \sin \left[360 \frac{284 + n}{365} \right] \quad (17)$$

The average monthly radiation values before atmosphere for Ankara (Turkey) used in calculating opacity factor is given with Table 2.

“ ϕ ” which is given in Eqs. (15) and (16), is the latitude degree, which is 40° for Ankara, “ ω ” is the hour angle,

and is 15° for every hour starting from 12:00, “ γ ” is the azimuth angle and is 60° for 16:00 and is analyzed as 0° due to the fact that the collector faces south. Furthermore, the “ r_a ” value in Eq. (12); the reflectivity coefficient is taken as 0.2 in order to calculate the total solar radiation of inclined plane’s perimeter.

Table 2. Monthly average radiation values before atmosphere for Ankara (Turkey), [W/m^2] (Uyarel and Öz, 1987).

Jan 4253	Feb 5725	March 7614	April 9562
May 10924	Jun 11479	Jul 11202	Aug 10062
Sept. 8310	Oct. 6253	Nov. 4585	Dec. 3747

The efficiency of the systems is given in Equation 18 (Shariah *et al.*, 2002).

$$\eta = \frac{\dot{Q}}{F_k I_{TOT}} \quad (18)$$

MATERIAL AND METHOD

Two indirect and natural circulation systems, one of which is classical and the other finned were designed and manufactured. The collector surface is 0.21 m^2 in both systems ($0.35\text{m} \times 0.60\text{m}$). System depot was insulated with 5 cm of fiberglass and connecting pipes were insulated with polyurethane insulating material. The collectors are inserted to the counter with a 25° angle (summer application), and the counter is inserted on the platform, which is 1.5 m high and their front sides are oriented to the south. Connection scheme is seen in Fig. 1. In order to calculate optimum fin size, the classical system (a) was tested first. In the classic system, the temperature of depot water was measured as 59.2°C for 16:00 and the temperature of the flow passing from the heat exchangers was measured as 68.1°C . The fin dimensioning was undertaken in accordance with these temperature values. Firstly the heat convection coefficient was calculated according to classical system experiment results. According to these data “ m ” coefficient was calculated with Eq. (4) for the finned system in order to determine fin height. Fin height was calculated from the $L=2 \times 3/m$ expression. After the all calculations the fin height was determined as 0.03 m for the finned system.

The sizes of the manufactured depot, fin and heat exchanger are given in Table 3, according to the calculations.

The fins used in the system are of made of black sheet metal, and has six fins which are 2 mm thick. They are tinned to cylindrical heat exchanger with electric arc welding. In Fig. 2, the fin detail is given. The performance can be increased by using different geometry and higher heat conduction coefficient fin materials.

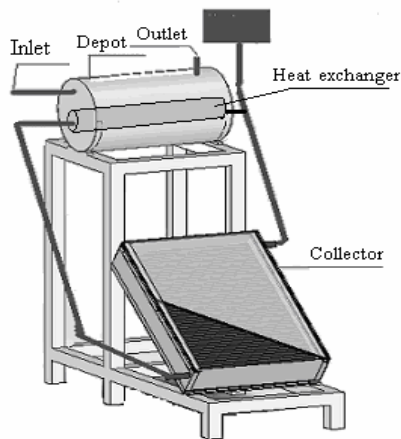

(a)

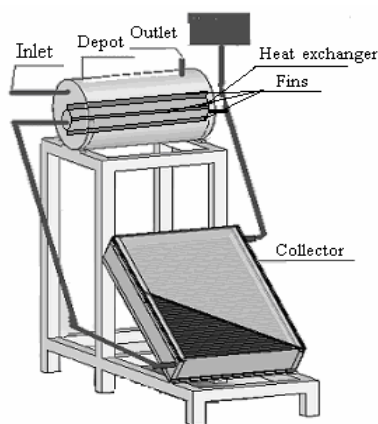

(b)

Figure 1. Connecting scheme of the systems, (a) classical systems, (b) finned systems.

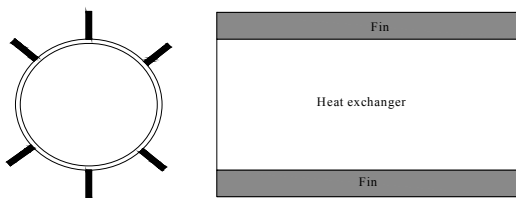

Figure 2. Fin detail.

Table 3. Depot, heat exchanger and fin sizes.

Systems	Capacity V (liter)	Length W (cm)	Diameter D (cm)	Height L (mm)
Classical System	Depot	15	31	25
	Fin	-	-	-
	Heat exchanger	0.39	31	4
Finned System	Depot	15	31	25
	Fin	-	31	-
	Heat exchanger	0.39	31	4

During this study in which fin dimensioning is made on the heat exchanger of the solar energy indirect domestic hot water systems, a classical system and the other system, in which fin dimensioning was made, are compared experimentally. The fin, which shall be used,

possesses an effectiveness of 6.07 and the optimum fin size is calculated as 0.03 m.

THE APPLICATION OF EXPERIMENTS

The sample sets were experimented for a 6-day period. The tests are conducted between 9:00 and 17:00. The meteorological values of the experiment days are given in Table 4.

Temperature measurements were made with Testo 922 temperature measurement device that is manufactured by TESTO company. The device has a LCD display and K type, double-output and NiCr-Ni thermocouples. The accuracy of this device as ± 0.005 and its measurement interval is $-50\text{ }^{\circ}\text{C} - 1000\text{ }^{\circ}\text{C}$.

Table 4. The meteorological values of the test days (Solar radiation data, 2001).

Experiment days	Day 1	Day 2	Day 3	Day 4	Day 5	Day 6
Radiation values, (kJ/m ² h)	17985	19969	19893	18864	20721	13964
Environmental air temperature, (°C)	28.8	29.6	29.4	28.0	28.0	27.7
Total sunshine, (hour)	11.5	12.3	12.2	11.7	12.2	7.9
Average cloudiness, (X/10)	3.3	0.0	0.0	1.7	0.0	5.3

RESULTS

The temperature measurements of the depot water on the experiment days are given in Fig. 3. The thermal efficiency measurements that are calculated for the experiment days are given in Table 5.

Table 5. The thermal efficiency of the systems for the experiment days.

Experiment days	Classical system	The finned system
1. Day	0.58	0.65
2. Day	0.53	0.60
3. Day	0.52	0.59
4. Day	0.53	0.60
5. Day	0.53	0.60
6. Day	0.56	0.64

CONCLUSIONS

According to the results of the experiment, the thermal efficiency of the classical system is calculated as 54 % and the thermal efficiency of the finned system is calculated as 61%. According to this result, it has been concluded that the usage of fins in the solar energy indirect hot water preparing systems is extremely useful for thermal efficiency. The thermal efficiency can be enhanced further by enhancing the fin effectiveness in the system. Choosing materials with a high heat conduction coefficient can achieve the enhancement of

the fin effectiveness. Furthermore, the fin effectiveness can be enhanced by increasing the proportion of the perimeter of the fin to its cross-section. It is determined that placing the fin in a way, which does not obstruct the flow, is extremely important.

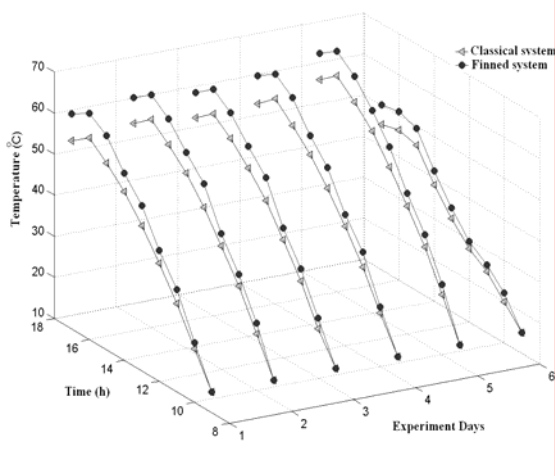

Figure 3. The measurements of the depot water on the experiment days.

REFERENCES

Aktaş, M., Güneş Enerjili Tabii Sirkülasyonlu Dolaylı Sıcak Su Hazırlama Sistemlerinde Kanatçık Optimizasyonu, *Yüksek Lisans Tezi*, Gazi Üniversitesi Fen Bilimleri Enstitüsü, Ankara, 53-99, 2003.

Güneş Işınımı Verileri, *Kalaba Meteoroloji Genel Müdürlüğü*, Ankara, 2001.

Halıcı F., Gündüz M., *Örneklerle Isı Geçişi*, Burak Ofset, Sakarya, 209-283, 2001

Incropera F. P., Dewitt, D.P., *Fundamentals of Heat and Mass Transfer*, John Wiley Sons, New York, 303-577, 1996.

Kakaç, S., *Örneklerle Isı Geçişi*, Seldem Ofset, Yedinci Cilt, Ankara, 153-156, 1987.

Öz E., S., Menlik T., Aktaş M., Güneş Enerjili Tabii Sirkülasyonlu Endirekt Sıcak Su Hazırlama Sistemlerinde Kanatçık Kullanmanın Isıl Analizi, *Teknoloji Dergisi, Zonguldak Karaelmas Üniversitesi Teknik Eğitim Fakültesi Dergisi*, 7 (2), 189-195, 2004.

Reddy, T., A., *The Design and Sizing of Active Solar Thermal Systems*, Oxford University Press, New York, 4-10, 1987.

Shariah, A., Al-Akhras, M., A., I.A. Al-Omari, I., A., Optimizing The Tilt Angle of Solar Collectors, *Renewable Energy*, 26, 587-598, 2002.

Uyarel, A. Y., Öz, E. S., *Güneş Enerjisi ve Uygulamaları*, Emel Matbaacılık, Ankara, 66, 1987.

Viesmann, *Solar Energy*, Viesmann, Ankara, 2-3, 1997.