



POLİTEKNİK DERGİSİ

JOURNAL of POLYTECHNIC

ISSN: 1302-0900 (PRINT), ISSN: 2147-9429 (ONLINE)

URL: <http://dergipark.org.tr/politeknik>



A software for the design and optimization of bolted joints under eccentric load

Eksantrik yük altındaki cıvatalı bağlantıların tasarımı ve optimizasyonu için bir yazılım

Yazar(lar) (Author(s)): Kadir SARI¹, Hakan DİLİPAK²

ORCID¹: 0000-0001-8013-8285

ORCID²: 0000-0003-3796-8181

To cite to this article: Sarı K., and Dilipak H., “A Software for the Design and Optimization of Bolted Joints Under Eccentric Load”, *Journal of Polytechnic*, 28(6): 1575-1592, (2025).

Bu makaleye şu şekilde atıfta bulunabilirsiniz: Sarı K., ve Dilipak H., “A software for the design and optimization of bolted joints under eccentric load”, *Politeknik Dergisi*, 28(6): 1575-1592, (2025).

Erişim linki (To link to this article): <http://dergipark.org.tr/politeknik/archive>

DOI: 10.2339/politeknik.1568347

A Software for The Design and Optimization of Bolted Joints Under Eccentric Load

Highlights

- ❖ Bolted joints under lateral load
- ❖ Design, analysis and optimization
- ❖ Software development
- ❖ Graphical user interface
- ❖ Increasing effectiveness and efficiency

Graphical Abstract

An interactive software was developed for analysis-based design and optimization of eccentrically loaded bolted joints using C# programming language in Visual Studio development environment.

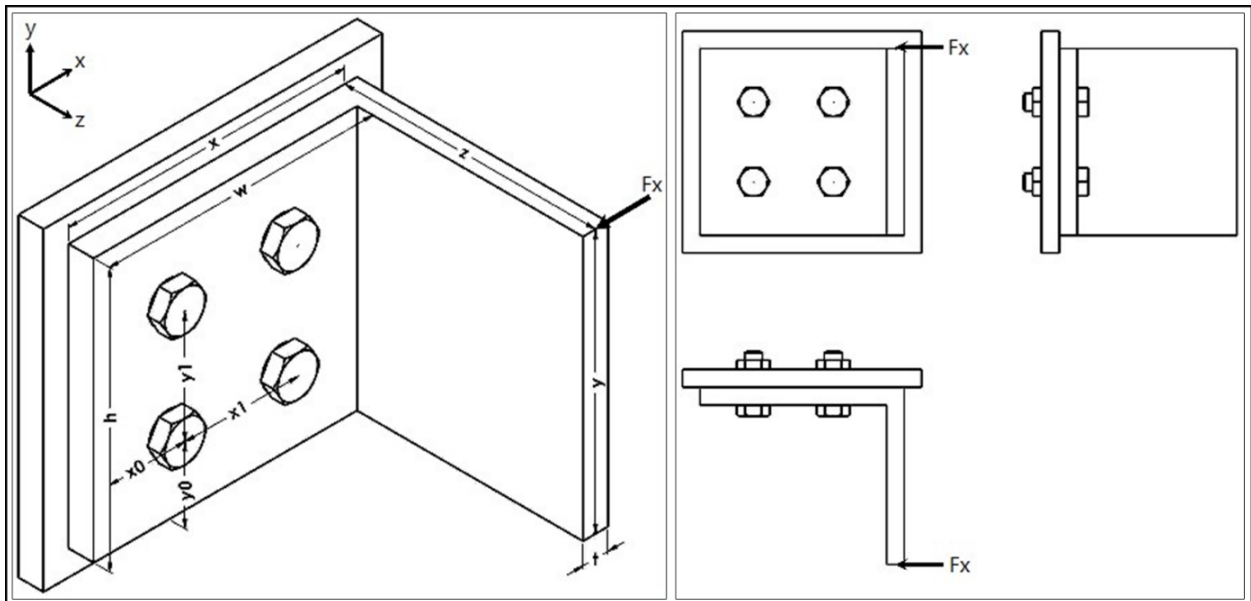

Figure. A Section of The Developed Software

Aim

It was aimed to minimize workload and time loss, facilitate the process and maximize productivity by obtaining optional and optimum results for the design of bolted joints with minimum user input.

Design & Methodology

A graphical user interface (GUI) was created for the software to receive user inputs for the bolted joint and provide design results for the target factor of safety.

Originality

For the design of eccentrically loaded bolted joints, optional and optimum results are automatically found by the software in one go according to the minimum user input in line with the target conditions, instantly reflected through the GUI, and as a result, the design analysis cycle is avoided.

Findings

The design-analysis cycle is avoided with a result and optimization-oriented strategy. Interactive, guided and practical use with GUI. A customizable structure was provided by establishing an integrated database.

Conclusion

Real-time software responds instantly to target problems with minimal external input, providing significant workload and time savings. The design and optimization of bolted joints is carried out effectively and efficiently.

Declaration of Ethical Standards

The author(s) of this article declare that the materials and methods used in this study do not require ethical committee permission and/or legal-special permission.

A Software for The Design and Optimization of Bolted Joints Under Eccentric Load

Araştırma Makalesi / Research Article

Kadir SARI^{1*}, Hakan DİLİPAK²

¹Graduate School of Natural and Applied Sciences, Manufacturing Engineering Department, Gazi University, Türkiye

²Faculty of Technology, Manufacturing Engineering Department, Gazi University, Türkiye

(Geliş/Received : 16.10.2024 ; Kabul/Accepted : 01.03.2025 ; Erken Görünüm/Early View : 03.04.2025)

ABSTRACT

Bolted joints are among the most reliable and common methods of securely joining objects. The design and analysis of these joints is important for speed and efficiency. Efficient systems can be created by optimizing properties such as size, quantity, material and safety. In this study, analysis-based design and optimization of bolted joints subjected to eccentric loads is addressed. In line with this goal, an interactive software named "DESOPT BJ" was developed using C# programming language in Visual Studio development environment. A user-friendly graphical interface with graphical designs was designed and a customizable integrated database was established. Template joint types with different bolt numbers and placements can be selected from the software. Design parameters and load conditions for the joint are taken as input. The software performs calculations within the scope of the database and optional results for the design are found by filtering according to the targeted factor of safety. In the optimization process, optimum results are obtained by applying diameter, strength and safety constraints for bolts and minimum and maximum conditions for these constraints on the optional results. The results include metric bolt, grade, yield strength and factor of safety parameters for the bolted joint. Optional and optimum results for bolted joints are calculated for template designs, minimum user input and database. Real-time software provides instantaneous responses. The graphical user interface adds interactivity and practicality to the design and optimization process. User workload is minimized and significant time savings are achieved. Software results and theoretical solutions offer 100% strong compatibility.

Keywords: Bolted joint, eccentric load, design, optimization, software.

Eksantrik Yük Altındaki Cıvatalı Bağlantıların Tasarımı ve Optimizasyonu İçin Bir Yazılım

ÖZ

Cıvatalı bağlantılar, nesnelerin emniyetli bir şekilde birleştirilmesinde kullanılan en güvenilir ve yaygın yöntemler arasında yer almaktadır. Bu bağlantıların tasarımı ve analizi, hız ve etkinlik açısından önem teşkil etmektedir. Boyut, miktar, malzeme ve emniyet gibi özellikler üzerinden optimizasyon sağlanarak verimli sistemler oluşturulabilmektedir. Bu çalışmada eksantrik yüklere maruz kalan cıvatalı bağlantıların analiz tabanlı tasarım ve optimizasyon konusu ele alınmıştır. Bu hedef doğrultusunda Visual Studio geliştirme ortamında C# programlama dili kullanılarak "DESOPT BJ" isimli etkileşimli bir yazılım geliştirilmiştir. Grafik tasarımlar içeren kullanıcı dostu bir grafik arayüzü tasarlanmıştır ve özelleştirilebilir entegre veri tabanı kurulmuştur. Yazılım üzerinden ilk olarak farklı cıvata sayısı ve yerleşimlerini içeren şablon bağlantı tipleri arasından seçim yapılmaktadır. Bağlantı için tasarım parametreleri ve yük koşulları girdi olarak alınmaktadır. Yazılım veri tabanı kapsamında hesaplamalar gerçekleştirilmekte ve hedeflenen emniyet katsayısına göre filtreleme yapılarak tasarım için opsiyonel sonuçlar bulunmaktadır. Optimizasyon sürecinde opsiyonel sonuçlar üzerinde cıvatalar için çap, dayanım ve emniyet kısıtları ve bu kısıtlar için minimum ve maksimum koşulları uygulanarak optimum sonuçlar elde edilmektedir. Sonuçlar, cıvatalı bağlantı için metrik cıvata, kalite, akma dayanımı ve emniyet katsayısı parametrelerini içermektedir. Şablon tasarımlar, minimum kullanıcı girdisi ve veri tabanı için cıvatalı bağlantıların opsiyonel ve optimum sonuçları hesaplanmaktadır. Gerçek zamanlı yazılım anlık yanıtlar vermektedir. Grafik kullanıcı arayüzü tasarım ve optimizasyon sürecine etkileşim ve pratiklik katmaktadır. Kullanıcı iş yükü en aza indirilmekte ve önemli oranda zaman kazancı sağlanmaktadır. Yazılım sonuçları ve teorik çözümler %100 güçlü uyumluluk sunmaktadır.

Anahtar Kelimeler: Cıvatalı bağlantı, eksantrik yük, tasarım, optimizasyon, yazılım.

1. INTRODUCTION

In today's industry, there are different methods for joining parts. One of these joint methods is the widely used bolted joints. The design, analysis and optimization process of bolted joints is extremely important for the efficiency of the system. This process has a comprehensive and complex structure that includes factors such as joint types, sizing, number of

components, material properties, load conditions and safety. Bolted joints that are not designed correctly are weak in terms of strength, resulting in damage, and negatively affect labor and costs by providing inefficient use due to an inefficient process. For these reasons, the design and analysis of bolted joints should be carried out within the framework of optimization to ensure the most suitable joints.

*Sorumlu Yazar (Corresponding Author)
e-posta : kadorsari@gaazi@gmail.com

Bolts are removable fasteners with different head shapes with screws on the cylindrical body. Bolts compress with their threads and prevent loosening. Bolted joints are formed as a result of joining two or more than two objects using machine elements such as bolts or nuts. Bolted joints are a safe joining method that provides ease of assembly and disassembly and are widely used. Figure 1 shows an example of a bolted joint.

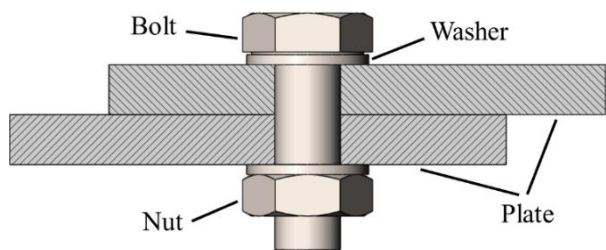

Figure 1. Bolted joint

There are some concepts and principles for bolted joint design. The key elements in the design process of bolted joints in the context of safety, effectiveness and efficiency are: joint characteristics, plates and number, bolt selection and number, material selection and properties, sizing, load conditions and locations, factor of safety.

Optimization is all the changes made to the parameters in order to optimize a system or process. The optimum value or the best solution can be found through the optimization process. Optimization problems and studies include the search for the minimum or maximum value and the achievement of one or multiple objectives. The term multi-objective optimization is used for problems with more than one objective. Such problems are found in engineering, aerospace, automotive, mathematics, economics and many other fields [1].

Examples of optimization of bolted joints include modifications to reduce material usage, reduce costs and provide more secure joints. In this study, size, quantity and material optimizations are generally included.

There are studies on bolted joints for different subjects and methods in the literature. The literature survey includes studies on bolted joints as well as other joint methods such as riveted joints and welded joints. Equations were derived to calculate the compliance and load factor for the durability case in the design of bolted joints [2]. An interactive software called PowerScrew was developed to facilitate the design and analysis of power screws, and the software speeds up engineers' calculations by automating the process of determining the diameter of the screw, calculating the factor of safety and finding the allowable load [3]. A plug-in called BOLJAT was developed to facilitate the modelling process of composite bolted joints with MSC.Patran finite element analysis [4]. A software with Visual Basic user interface based on ANSYS finite element analyses and artificial neural network was developed to find the stiffness of bolted joints in a short time [5]. The interactive courseware developed for analyzing and

designing bolted joints asks the user to input the joint geometry, materials and loads and provides a report that calculates the factor of safety and other design parameters [6]. A computer program was developed for the purpose of designing and analyzing riveted and bolted joints that are subjected to compound loading [7]. A software for the analysis and design of riveted joints was developed. It covers lap and butt joint type options. Through the software, safety, rivet diameter and number, plate width and thickness can be found for a riveted joint under a given loading [8]. A software was developed for use in the design process of welded joints. The user specifies the design target as factor of safety or weld thickness. The user can select the weld geometry from the existing designs or create a customized weld geometry. All other parameters such as loading types, materials, etc. for the joint are also entered into the software and the desired design result is calculated [9]. A finite element model was constructed for the purpose of analyzing the effects of load distributions on bolts and laminates for composite bolted joints [10]. A multi-objective optimization model for the position of bolts for uniform distribution of loads in multi-loaded bolted joints was developed using Nastran finite element software [11]. Single and four-bolt joints with two different plates consisting of different materials as mild steel and E-glass fiber were studied using finite element analysis (FEA). By varying the material types of the plates and bolts, the tensile and crushing stress distribution on different bolts was analyzed [12]. A software was developed with "Visual Basic 6.0" program for computer-aided design of riveted joints in order to realize the design accurately and quickly. It covers the design of different types of riveted joints [13]. A design tool was developed for the analysis of bolted flange joints under axial, shear and moment load conditions based on artificial neural network (ANN) technique [14]. Loosening rate prediction of bolted joints subjected to vibration was studied in MATLAB environment and ANN technique [15]. A tool was developed using the Excel package program for the purpose of analysis and design, with the objective of calculating the strength of connecting rod bolts for internal combustion engines [16]. A methodology for the optimization of the shape and topology of bolted joints was developed, focusing on the optimization of the number and position of bolts used in the joints [17]. A methodology for the reliable prediction of damage in high-strength steel bolted joints was studied, employing machine learning techniques [18]. The bearing capacity of single lap and single bolt shear critical joints was investigated numerically [19]. An expert system called "Exbolt System" was developed using the CLIPS programming language to automate the decisions that require expertise in bolt selection in bolted joints and to determine the most appropriate bolt head type [20]. In order to automate the design and optimization of bolted joints under lateral load, a software interfaced with C# programming language was developed in Visual Studio development environment

and a system was created that finds the optimum bolt diameter, number and quality class (strength class) according to user inputs, lists design options and automatically draws [21]. In order to optimize the design of bolted joints and reduce the user load, a software called "BJD SOFT" was developed using C# and a system was developed that automatically calculates bolt placement and plate dimensions with minimal data from the user through the interface created [22]. In order to facilitate the design and optimization of bolted joints subjected to lateral loads on the basis of analysis, a software called "LLBJ TOOL" with a graphical user interface was developed in C# and the optimum bolt and plate design was automatically calculated and automatically drawn with minimum user input [23].

In the literature, studies on the design, analysis and optimization of bolted joints have a wide range of theoretical modeling and practical applications, making significant contributions to increase productivity in engineering. Many methods have been used in this field, ranging from developing equations for evaluating the strength and load distribution of joints to automating the design process with interactive software tools such as PowerScrew, BOLJAT, Exbolt System, BJD SOFT, LLBJ TOOL. In addition, modern approaches such as artificial intelligence techniques such as artificial neural networks, machine learning, expert systems, etc. were integrated with programming and analysis methods such as ANSYS, Nastran, Visual Basic and C# to optimize the parameters such as safety, stiffness and relaxation rate of bolted joints, riveted and welded joints, which are other joining methods. These studies, supported by multi-objective optimization models and finite element analysis, aimed to improve the performance of fasteners under various loading conditions, while at the same time accelerating the design process and reducing the workload by developing software with user-friendly, visual interfaces. In this context, studies in the literature reveal that the interdisciplinary approach to joint design and the integration of computer-aided engineering tools play a critical role in producing safe and efficient engineering solutions.

The present study differs from various software and analysis approaches in the literature as a software development that targets the design and optimization of bolted joints under eccentric load and stands out with its user-friendly graphical interface and automatic data processing features. The studies in the literature are generally aimed at optimizing the parameters such as safety, stiffness, load distribution of fasteners under different fasteners, joint types and loading conditions and supported by methods such as artificial intelligence techniques and finite element analysis using different development environments. On the other hand, in the present study, a software with an interactive graphical user interface that eliminates the design-analysis cycle by taking into account the complex impact mechanisms brought about by eccentric loads and presents the optimum design options in one go, filtering according to

the factor of safety and other design parameters, and applying optimization based on constraints and conditions has been developed. The automated structure of the developed software offers more specific and efficient solutions compared to similar studies in the literature in terms of speeding up the calculation processes and reducing the workload with minimum user input.

This study aimed to automate the design, analysis and optimization processes of bolted joints under eccentric load, eliminating the time loss and complex design-analysis cycles experienced in traditional methods. The software, developed in Visual Studio environment using C# programming language, allows the user to select from ready-made joint types, enter design parameters and load conditions easily with its intuitive and guided user-friendly graphical interface, and automatically calculates and presents design options according to the targeted factor of safety condition in line with the entered data. Thanks to the optimization system, optimum results are provided as output. The software has come to the forefront as a practical tool that provides efficient and fast design of bolted joints under eccentric load conditions in an automatic way thanks to the compatibility of the obtained results with theoretical solutions, the reliability of the software, the minimization of user input, the simultaneous evaluation of different design options and interactive database support.

2. BOLTED JOINTS UNDER ECCENTRIC LOAD

2.1. Bolted Joints Under Eccentric and Perpendicular Load

In this type of joint, the load is perpendicular to the bolt axis and offset from the center of gravity of the bolt group, that is, eccentric. The effect of the load is mainly direct primary shear forces. Secondary shear forces occur in the bolts as a result of the torsional moment in the joint due to the eccentricity. In addition, due to the eccentricity, a bending moment occurs in the joint, causing tensile forces on the bolts. This joint type is given in Figure 2. Then the related calculations are presented [24, 25, 26].

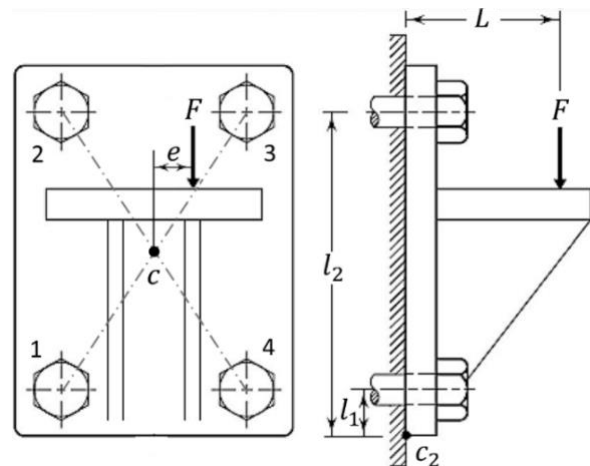

Figure 2. Bolted joint under eccentric and axial load [27]

Primary Shear Force

The bolts are directly subjected to a shear stress due to the applied load (Figure 3).

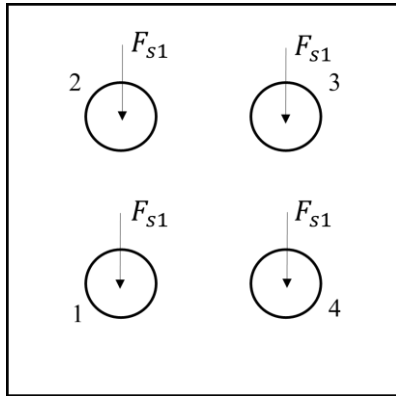

Figure 3. Direct shear force

The shear load to which each bolt is subjected is calculated by dividing the total load by the number of bolts (Eq. 1).

$$F_{s1} = \frac{F}{n} \tag{1}$$

F : Force (N)

F_{s1} : Direct shear force (N)

n : Number of bolts

Secondary Shear Forces

The eccentricity of the applied load creates a moment at the center of gravity of the bolt assembly (Figure 4).

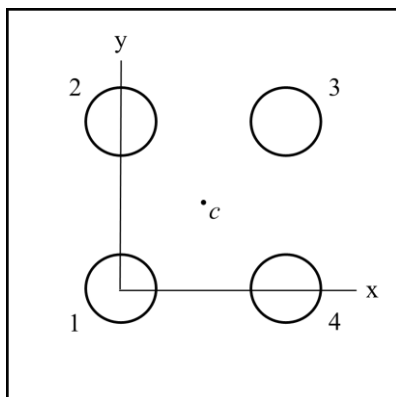

Figure 4. Centre of gravity of the bolt group

Centre of Gravity of The Bolt Group

The center of gravity is calculated according to the x and y coordinates given in the figure below (Eqs. 2 – 3).

$$x_c = \frac{x_1 * A_1 + x_2 * A_2 + \dots + x_n * A_n}{A_1 + A_2 + \dots + A_n} \tag{2}$$

$$y_c = \frac{y_1 * A_1 + y_2 * A_2 + \dots + y_n * A_n}{A_1 + A_2 + \dots + A_n} \tag{3}$$

x_c : Distance of the center of gravity in the x-axis (mm)

y_c : Distance of the center of gravity in the y-axis (mm)

x_i : Distance of the bolt in x-axis (mm)

y_i : Distance of the bolt in y-axis (mm)

A_i : Cross-sectional area of bolt *i* (mm)

In the joint under the effect of torsional moment, forces forcing the bolts to cut are generated under the effect of the moment. Formulations for the calculation of these forces are given below (Eqs. 4 – 14). In this instance, the center of gravity of the bolt assembly is designated as the pivot point (Figure 5).

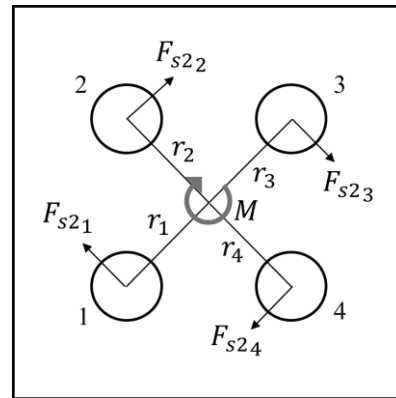

Figure 5. Bolted joint under torsional moment effect

The resulting moment is multiplied by the applied load and the perpendicular distance of the center of gravity to the force.

$$M = F * e \tag{4}$$

The normal distance (radius) of the bolts to the center of gravity is calculated with x and y (axes) components.

$$\sum r_x^2 = r_{x1}^2 + r_{x2}^2 + \dots + r_{xn}^2 \tag{5}$$

$$\sum r_y^2 = r_{y1}^2 + r_{y2}^2 + \dots + r_{yn}^2 \tag{6}$$

$$\sum r^2 = \sum r_x^2 + \sum r_y^2 \tag{7}$$

It can also be calculated in another way.

$$r_i = \sqrt{r_{xi}^2 + r_{yi}^2} \tag{8}$$

$$\sum r^2 = r_1^2 + r_2^2 + \dots + r_n^2 \tag{9}$$

The shear forces on the horizontal and vertical axis (x and y) of the bolts due to the torsional moment are calculated.

$$F_{s2xi} = \frac{M * r_{yi}}{\sum r^2} \tag{10}$$

$$F_{s2yi} = \frac{M * r_{xi}}{\sum r^2} \tag{11}$$

The total shear force is calculated as the resultant of the forces on the x and y axes.

$$F_{s_{x_i}} = F_{s_{2x_i}} \quad (12)$$

$$F_{s_{y_i}} = F_{s_1} + F_{s_{2y_i}} \quad (13)$$

$$F_{s_i} = \sqrt{F_{s_{x_i}}^2 + F_{s_{y_i}}^2} \quad (14)$$

M : Moment (N.mm)

F : Force (N)

F_{s1} : Direct shear force (N)

F_{s2} : Shear force due to moment effect (N)

F_s : Total shear force (N)

e : Perpendicular distance of center of gravity to force (mm)

r : Radius from the center to the bolts (mm)

r_x : x component for r (mm)

r_y : y component for r (mm)

Tensile Forces

As a result of the bending moment occurring in the joint due to the applied eccentric load, tensile forces occur in the bolts and are calculated as follows (Eq. 15).

$$F_{t_i} = \frac{F * L * l_i}{l_1^2 + l_2^2 + \dots + l_n^2} \quad (15)$$

F : Force (N)

F_t : Tensile force on the bolt (N)

L : Perpendicular distance of rotation point to force (mm)

l_i : Perpendicular distance of rotation point to bolt i axis (mm)

Total Stress and Factor of Safety

The shear stresses and tensile stresses occurring in the bolts are calculated. Then the combined (maximum) stress and the factor of safety of the joint are calculated (Eqs. 16 – 21).

$$\sigma_s = \frac{F_s}{A_c} \quad (16)$$

$$A_c = \frac{\pi * d_c^2}{4} \quad (17)$$

$$\sigma_t = \frac{F_t}{A_t} \quad (18)$$

$$A_t = \frac{\pi * d_t^2}{4} \quad (19)$$

$$\sigma_{max} = \sigma_b = \sqrt{\sigma_t^2 + (3 * \sigma_s^2)} \quad (20)$$

$$S (FOS) = \frac{\sigma_y}{\sigma_{max}} \quad (21)$$

F_t : Total tensile force on the bolt (N)

F_s : Total shear force on the bolt (N)

d_c : Bolt pitch circle diameter (mm)

d_t : Bolt tensile stress diameter (mm)

A_c : Bolt cross-sectional area for d_c (mm²)

A_t : Bolt cross-sectional area for d_t (mm²)

σ_{max} : Maximum stress generated (MPa)

σ_y : Material yield strength (MPa)

S : Factor of safety (FOS)

2.2. Bolted Joints Under Eccentric and Axial Load

In this type of joint, the load is parallel to the bolt axis and does not pass through the center of gravity of the bolt group, in other words, it is eccentric (Figure 6). The formulations for this type of joint are given below after the figure (Eqs. 22 – 29) [25, 26, 28].

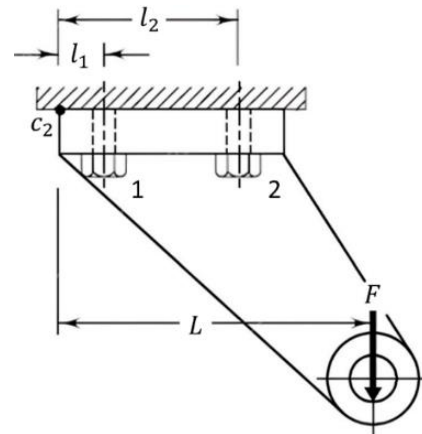

Figure 6. Bolted joint under eccentric and axial load [27]

The eccentricity generates a moment, which in turn generates a tensile stress in the bolts.

Tensile Force

As a result of the load, a direct force is generated on the bolts, resulting in a primary tensile force (F_{t1}). Due to the eccentricity of the force, moment is generated and secondary tensile forces (F_{t2}) are generated. Primary tensile forces are equal to each bolt. Secondary tensile forces vary according to the position of the bolts due to the moment. The highest secondary tensile force (F_{t2max}) is determined and summed with the primary tensile force and the final tensile force (F_t) is found to determine the bolt subjected to the highest force.

$$F_{t1} = \frac{F}{n} \quad (22)$$

$$F_{t2_i} = \frac{F * e * l_i}{l_1^2 + l_2^2 + \dots + l_n^2} \quad (23)$$

$$F_t = F_{t1} + F_{t2max} \quad (24)$$

Calculation of Maximum Stress and Safety Condition

The maximum stress is calculated by dividing the resulting tensile force by the bolt tensile stress area (Eqs. 25 – 27). The factor of safety of the joint is

calculated by dividing the proof strength of the material by the maximum stress (Eqs. 28 – 29).

$$\sigma_{max} = \frac{F_t}{A_t} \quad (25)$$

$$d_t = d * 0.85 \quad (26)$$

$$A_t = \frac{\pi * d_t^2}{4} \quad (27)$$

$$\sigma_p = \sigma_y * 0.85 \quad (28)$$

$$S (FOS) = \frac{\sigma_p}{\sigma_{max}} \quad (29)$$

n : Number of bolts

F : Force (N)

F_{t1} : Direct tensile force (N)

F_{t2} : Secondary tensile force due to moment effect (N)

F_t : Total tensile force (N)

L : Perpendicular distance of rotation point to force (mm)

l_i : Perpendicular distance of rotation point to bolt i axis (mm)

d : Bolt nominal diameter (mm)

d_c : Bolt pitch circle diameter (mm)

d_t : Bolt tensile stress diameter (mm)

A_t : Bolt cross-sectional area for d_t (mm²)

σ_{max} : Maximum stress generated (N)

σ_y : Material yield strength (MPa)

σ_p : Material proof strength (MPa)

S : Factor of safety (FOS)

2.3. Preloaded Bolted Joints

Bolts are used to clamp two or more parts together. By tightening the nut, the bolt is stretched and a compressive force is produced. The compressive force exerted by a bolt on a joint is often referred to as bolt preload or prestress [29]. It is generated spontaneously in the joint when the nut is properly tightened, regardless of whether an external tensile load (P) is applied or not. Since the members are interlocked, the clamping force generating tension in the bolt produces a compressive effect on the members [25].

Preload is the initial stress applied to the bolt during assembly in bolted joints. This stress is created to ensure a tight contact between the fasteners and helps to prevent the joint from separating or loosening under applied external loads. The preload on the bolt increases the mechanical strength of the system by closing the gaps between the fasteners and ensuring a more homogeneous load transfer.

In preloaded bolted joints, the bolts are assembled in line with a targeted prestress value. This is important to minimize the effects of dynamic loads, vibrations and thermal expansion. The preload in the joint controls the elastic deformation of the bolt under external loads, thereby increasing the frictional force between the fasteners and providing a safer distribution of the load.

The formulations for the preload case are given below (Eqs. 30 – 35) [25, 26].

Forces are generated on the bolts due to preload and external loads. The stiffness of the fastener and the joined members is also taken into account by the stiffness constant C .

$$F_b = P * C + F_i \quad (30)$$

Similarly, a clamping force is generated on the joined members.

$$F_m = P * (1 - C) - F_i \quad (31)$$

A stiffness constant C is used to calculate the forces on the bolts and joined members. The value of the constant C is determined by the spring rates of the bolts and fasteners. The formulation for finding the constant C is as follows.

$$C = \frac{k_b}{k_b + k_m} \quad (32)$$

In preloaded bolts, the greater the normal force (contact force), the greater the resistance of the joint to shear, since the shear force is carried by friction between the surfaces. The normal force (N) is the perpendicular force exerted by the fasteners on each other and is generated by tightening the bolt. The coefficient of friction (μ) determines the effectiveness of the friction force (F_f) between the joint surfaces. The shear force value is used for the friction force when calculating the normal force capable of carrying the shear force.

$$F_f = \mu * N \quad (33)$$

$$N = \frac{\sum F_s}{\mu} \quad (34)$$

In preloaded bolted joints, it is critical to maintain the normal force so that the joint does not loosen and slip. As the shear force increases, sufficient normal force must be maintained for the joint to resist slipping. The normal force is related to the clamp force. The normal force and the clamp load are of equal magnitude but act in opposite directions. Accordingly:

- The normal force (N) is the internal force applied to the joint surfaces when the bolt is tightened.
- The clamp load (F_m) is the compressive force holding the joint together.

This balance, given by the equation below, ensures that pre-loaded bolted joints are resistant to slipping and loosening.

$$F_m = -N \quad (35)$$

F_i : Preload force (N)

F_b : Force on the bolt (due to preload and external load) (N)

F_m : Force on the clamped members (N)

P : External load (N)

N : Normal force (N)

μ : Coefficient of friction

C : Joint stiffness constant

k_b : Bolt spring rate (stiffness of bolt)

k_m : Members spring rate (stiffness of members)

3. DEVELOPED SOFTWARE

A software called “DESOPT BJ” with a graphical user interface has been developed for analysis-based design and optimization of bolted joints under eccentric load. The software development was performed in Visual Studio integrated development environment using WPF user interface development framework and C# programming language. WPF enables the creation of modern, customizable and rich graphical interfaces. The C# language has a structure suitable for graphical operations and processes, can be adapted to many different systems and is widely used. The Visual Studio program offers a strong integration with C#.

MS Excel package program, which offers practical and powerful features for the software database, was used and integrated into the software.

Due to such situations, the mentioned programs and development technologies were preferred in this study.

3.1. Software Structure

The software provides optional and optimum results for the design of bolted joints under eccentric load based on user inputs and database. The mathematical operations

and algorithms performed during the design process are performed automatically in the software background. The software can be used practically and intuitively through an interactive and guided graphical user interface.

Software Technical Infrastructure

The developed software runs on Windows operating systems and does not require any additional system requirements. The software offers a lightweight and optimized structure, so it can also run on low-equipped systems. The software performs all calculations and operations in real time. In this way, it responds to user inputs instantly and does not require waiting time.

3.2. Database

An interactive and customizable database integrated into the software and interface was created to be used in the design, analysis and optimization process. The database for bolted joints includes diameter values, strength classes (grade) and strength values for metric bolts. By accessing the database, adding, editing and deleting operations can be performed.

The scope of the bolts was determined using the metric bolts and associated diameter values in the standard “ISO 898-1: Mechanical properties of fasteners” [30]. Diameter values for metric bolts are given below in Table 1.

Table 1. Diameter values for metric bolts

Nominal Diameter (mm)	Pitch Circle Diameter (mm)	Tensile Diameter (mm)
3	2,675	2,550
3,5	3,110	2,975
4	3,545	3,400
5	4,480	4,250
6	5,350	5,100
7	6,350	5,950
8	7,188	6,800
10	9,026	8,500
12	10,863	10,200
14	12,701	11,900
16	14,701	13,600
18	16,376	15,300
20	18,376	17,000
22	20,376	18,700
24	22,051	20,400
27	25,051	22,950
30	27,727	25,500
33	30,727	28,050
36	33,402	30,600
39	36,402	33,150

The data on the strength classes of bolts were generated from the information provided in the ISO 898-1 standard

entitled “Mechanical properties of fasteners” [30]. Bolt strength classes and strength values are given in Table 2.

Table 2. Bolt strength classes (grades) and strength values

Bolt Strength Class	Yield Strength (MPa)	Proof Strength (MPa)
4.6	240	204
4.8	320	272
5.6	300	255
5.8	400	340
6.8	480	408
8.8	640	544
9.8	720	612
10.9	900	765
12.9	1080	918

3.3. Presentation and Use

In the developed software, an interface was designed for the software developed within the scope of bolted joints under eccentric load. The interface consists of database, joint design area, joint types, user input and results sections. The database section contains data related to bolts. The design area is the section that helps to realize the design of bolted joints with different views. In the

joint types section, there are bolted joint types with various number of bolts and their layouts. In the user input section, users provide inputs for the parameters and optimization of the bolted joint and its design. The results section shows the design results with different options according to the inputs. These sections are explained in detail in the following paragraphs. The software interface is given in Figure 7.

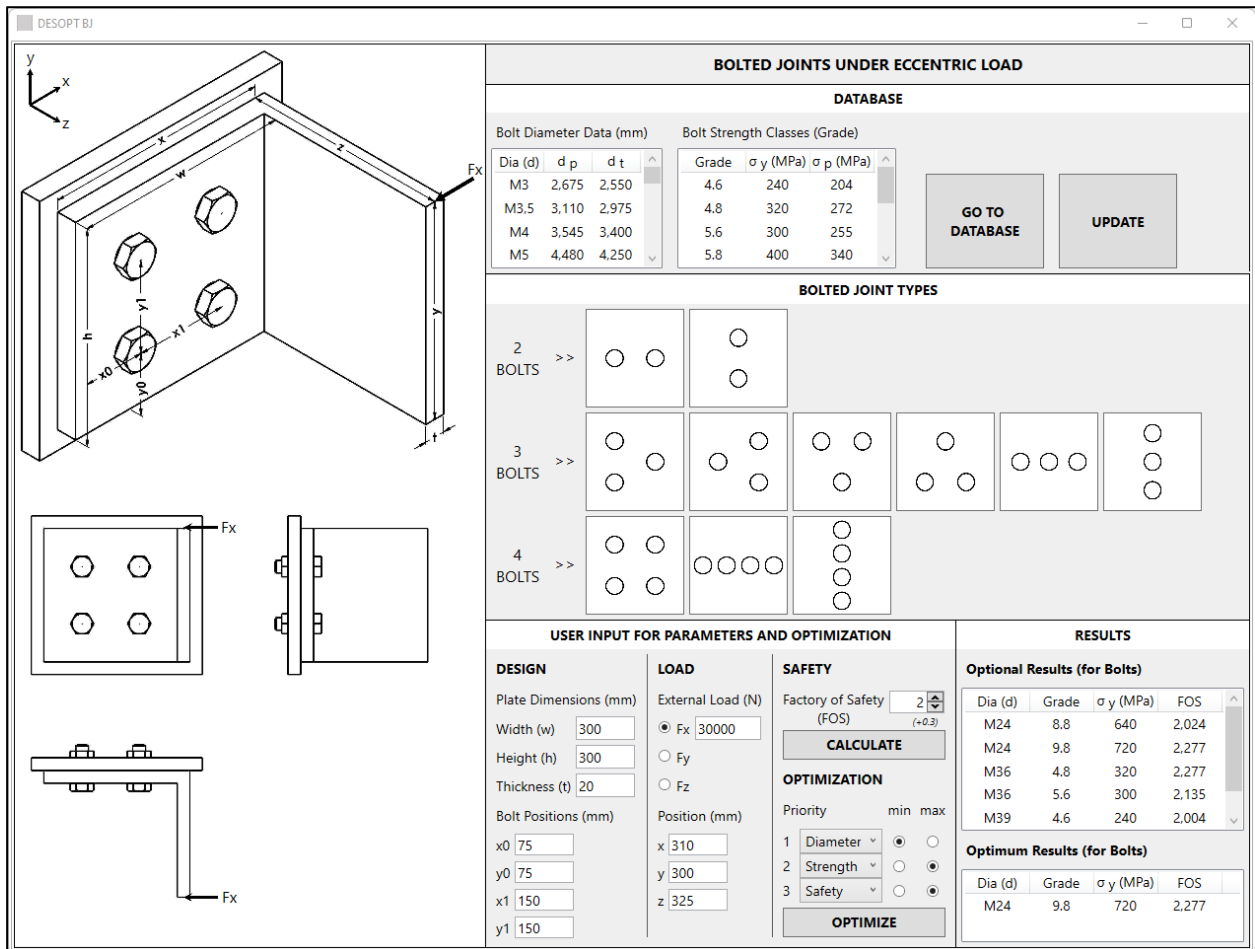

Figure 7. Interface

An interactive and customizable structure was provided by building an integrated database into the software. The database section (Figure 8) contains data on bolts,

including metric bolts, auxiliary diameter dimensions, strength classes (grade) and strength values. The database is stored in an Excel file. The data is extracted from the

Excel file and listed in the database section of the interface. Users are given the opportunity to customize the database. It is possible to interact with the database through buttons. By clicking the “GO TO DATABASE” button, users can switch to the Excel file and add, delete

and edit operations can be performed on the database. With the “UPDATE” button, the current data from the Excel file is brought to the relevant section in the software interface.

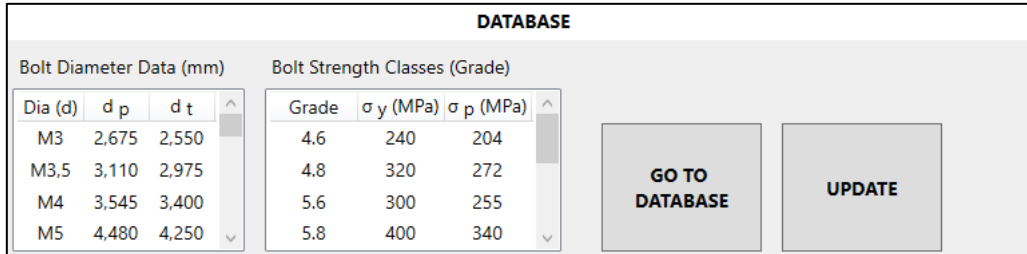

Figure 8. Database

The database created with the MS Excel package program is given in Figure 9 below. The database kept in Excel environment can be interacted with. Adding, editing and deleting operations can be done by the user to this database. By applying filters, query operations can

be performed for the desired data. Data can be sorted in ascending or descending order. This database was integrated into the software developed. The software pulls data from the Excel database and uses it in the design and optimization process.

DATABASE						
Bolt Diameter Data (mm)			Bolt Strength Classes (Grade)			
d	dp	dt	Grade 1	Grade 2	σ _y (MPa)	σ _p (MPa)
3	2,675	2,550	4	6	240	204
3,5	3,110	2,975	4	8	320	272
4	3,545	3,400	5	6	300	255
5	4,480	4,250	5	8	400	340
6	5,350	5,100	6	8	480	408
7	6,350	5,950	8	8	640	544
8	7,188	6,800	9	8	720	612
10	9,026	8,500	10	9	900	765
12	10,863	10,200	12	9	1080	918
14	12,701	11,900				
16	14,701	13,600				
18	16,376	15,300				
20	18,376	17,000				
22	20,376	18,700				
24	22,051	20,400				
27	25,051	22,950				
30	27,727	25,500				
33	30,727	28,050				
36	33,402	30,600				
39	36,402	33,150				

Figure 9. MS Excel database

In the joint types section (Figure 10), there are 2, 3 and 4 bolt joint types and different bolt placements for each bolt number. These joint types can be selected and their

detailed view is reflected in the design area by the software.

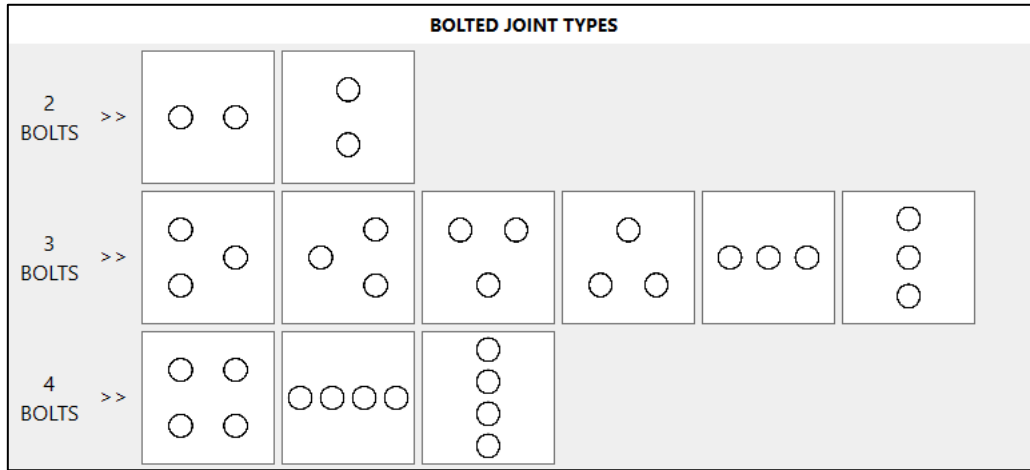

Figure 10. Bolted joint types

The design area (Figure 11) includes a perspective view of the bolted joints and 3 views as front, top and left side.

In these views, plate dimensions, bolt positions and force information are given in detail and reflected to the user.

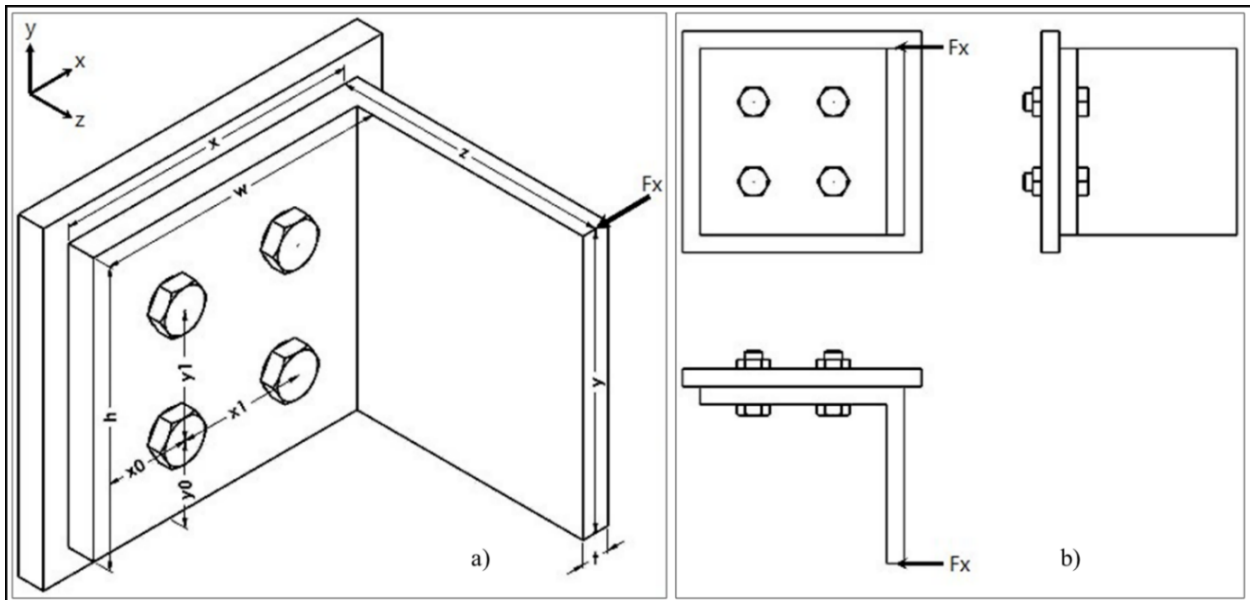

Figure 11. Design area: a) Perspective view, b) Three views

In the user input section, plate dimensions, bolt locations, force information and factor of safety for filtering purposes are taken as input. Plate dimensions include width, height and thickness parameters. Bolt positions are applied by typing the horizontal and vertical positions for each bolt on the x and y axis into the relevant boxes on the interface. The section where load information is entered includes the direction, size and position parameters of the applied force. The force direction can be given in 3 different ways as x, y and z axes in 3 dimensions. The magnitude of the force applied in the selected force direction is written in the relevant field in units of N. The position of the force is taken as input in 3 axes as x, y, z. In the safety section, the desired factor of safety value for the joint is entered. With this value, the optional results within the tolerance range of +0.3 are

automatically found and listed in the sub-section titled “Optional Results” in the “RESULTS” section.

After the parameter entries are made, the “CALCULATE” button is pressed and the software automatically performs the necessary calculations for the bolted joint in the background.

In the optimization section, the optimum results are determined over the optional results for the design. For the bolts, there is a prioritization system for diameter, strength and safety constraints as 1, 2 and 3 in order from high to low level. Minimum (min) and maximum (max) conditions can be assigned for these constraints. By pressing the “OPTIMIZE” button, the optimum results for the design according to these optimization settings are reflected to the user as output in the subsection titled “Optimum Results” in the “RESULTS” section. The “USER INPUT” section is given in Figure 12.

USER INPUT FOR PARAMETERS AND OPTIMIZATION		
DESIGN	LOAD	SAFETY
Plate Dimensions (mm)	External Load (N)	Factory of Safety <input type="text" value="2"/> <small>(FOS)</small>
Height (h) <input type="text" value="300"/>	<input checked="" type="radio"/> Fx <input type="text" value="30000"/>	<input type="text" value="2"/> <small>(+0.3)</small>
Width (w) <input type="text" value="300"/>	<input type="radio"/> Fy	CALCULATE
Thickness (t) <input type="text" value="20"/>	<input type="radio"/> Fz	OPTIMIZATION
Bolt Positions (mm)	Position (mm)	Priority <input type="text" value="min"/> <input type="text" value="max"/>
x0 <input type="text" value="75"/>	x <input type="text" value="310"/>	1 Diameter <input checked="" type="radio"/> <input type="radio"/>
y0 <input type="text" value="75"/>	y <input type="text" value="300"/>	2 Strength <input type="radio"/> <input checked="" type="radio"/>
x1 <input type="text" value="150"/>	z <input type="text" value="325"/>	3 Safety <input type="radio"/> <input checked="" type="radio"/>
y1 <input type="text" value="150"/>		OPTIMIZE

Figure 12. User input area

The optimization algorithm applies an iterative filtering process to select the most optimal among the optional results for the design according to the design parameters (diameter, strength and safety) specified by the user and the minimum or maximum conditions defined for each parameter. At the beginning of the algorithm, all optional results are considered as candidates. Then the constraints specified by the user are processed sequentially. In each

constraint step, the optimum (minimum or maximum) value is determined among the available candidates for the relevant parameter and only the results with this value are filtered. In addition, the loop terminates automatically if the number of candidates is 1 in the filtering process. The outputs obtained when all constraints and conditions are applied are presented as optimal results. The optimization algorithm is given in Figure 13.

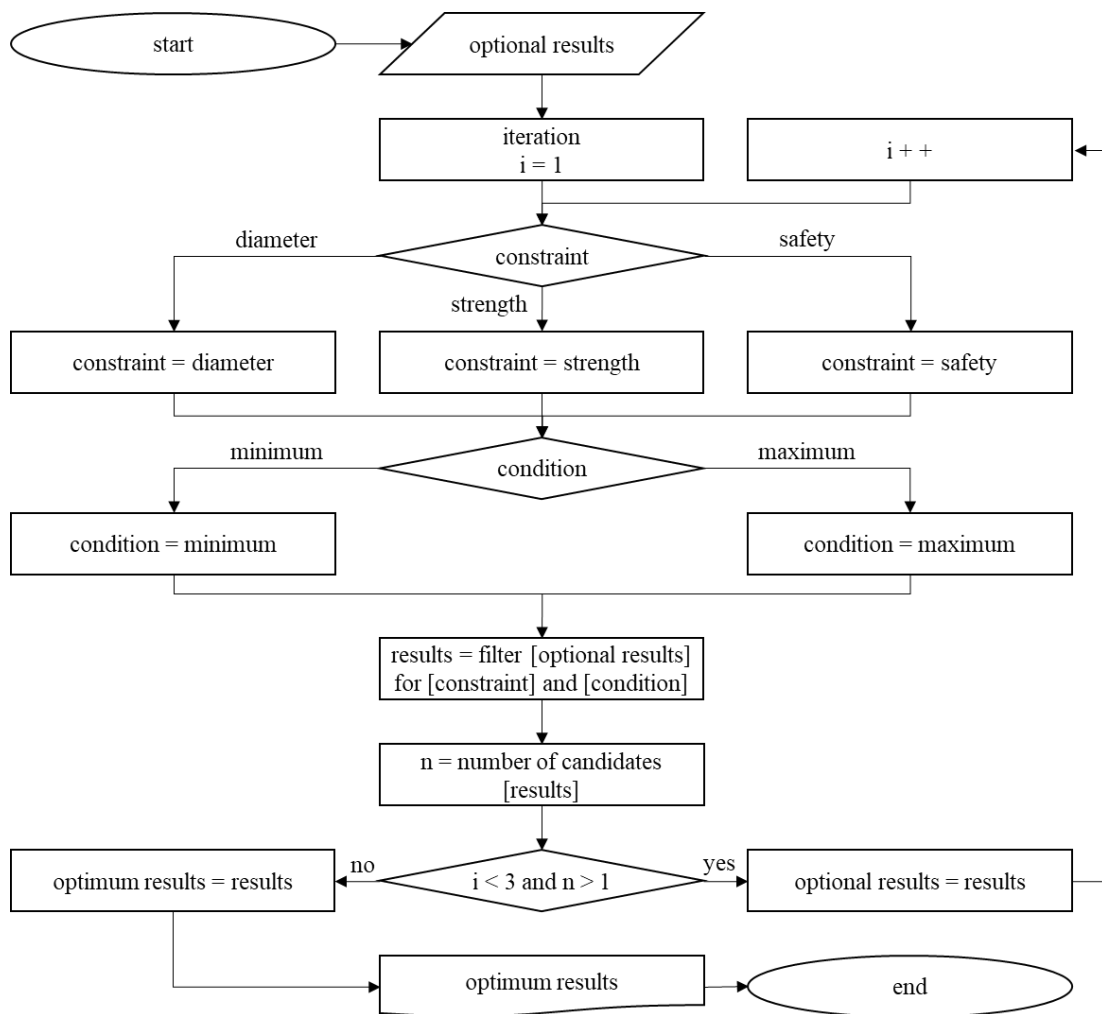

Figure 13. Optimization algorithm

In this process, conditions such as the forces and stresses on the bolts as a result of eccentric loads experienced by preloaded bolted joints were taken as a basis.

Using the input parameters and the diameter and strength class (grade) data of the bolts in the database, the optional results for different designs and the factor of safety for each result are calculated.

The designs that meet the factor of safety condition are filtered and the optional results are listed in a list tool called “Optional Results” in the results section. With the listing, the user is presented with results for the design including diameter, grade, yield strength and factor of safety information for the metric bolt. The user can choose among the options and obtain the appropriate bolted joint design. Finally, the optimum results determined by the software by applying the optimization system are given as output in the section titled “Optimum Results”. Using this output, the optimum bolted joint design is realized. The “RESULTS” section is given in Figure 14.

RESULTS			
Optional Results (for Bolts)			
Dia (d)	Grade	σ_y (MPa)	FOS
M24	8.8	640	2,024
M24	9.8	720	2,277
M36	4.8	320	2,277
M36	5.6	300	2,135
M39	4.6	240	2,004
Optimum Results (for Bolts)			
Dia (d)	Grade	σ_y (MPa)	FOS
M24	9.8	720	2,277

Figure 14. Results

3.4. Example Study

A study was carried out by realizing a sample application on the developed software. The example application covers a bolted joint system formed by joining 2 parts using 3 bolts. The placement of the bolts is arranged so that there are 2 bolts at the top and 1 bolt at the bottom. An eccentric load acts on the system in the direction and position indicated in the figure. The eccentric load is 16 000 N. Bolted joint and design parameters for Figure 15 are as follows.

Plate Dimension	width (w) = 420 mm
	height (h) = 410 mm
	thickness (t) = 20 mm
Bolt Positions	$x_0 = 100$ mm, $y_0 = 100$ mm
	$x_1 = 220$ mm, $y_1 = 210$ mm
External Load and Position	$F_y = 16\,500$ N
	$x = 430$ mm
	$y = 410$ mm
	$z = 375$ mm

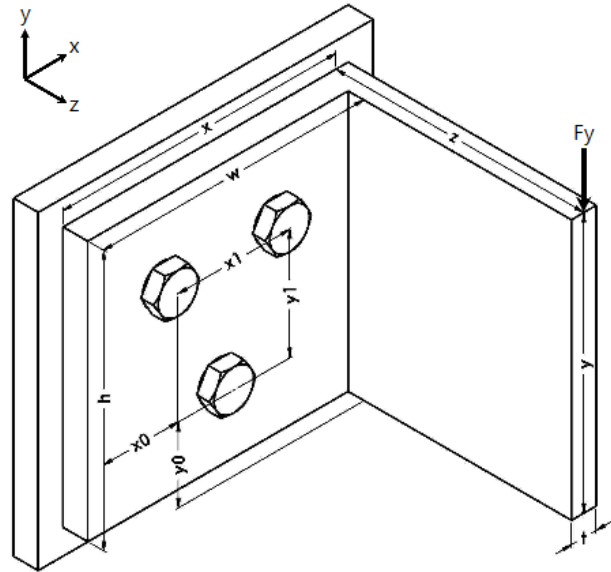

Figure 15. Application for bolted joint under eccentric load

The factor of safety is set to 3 and is within the tolerance range of +0.3. Constraints and conditions were defined in the optimization process. The order of priority is as follows: maximum safety, minimum bolt diameter and maximum strength.

According to all this information, it was aimed to find the optimum bolt that could be used in the joint through its properties such as diameter, grade and yield strength.

In line with this sample system, the number and arrangement of bolts on the joint was selected from the joint type section on the software. Parameters related to the bolted joint in the system such as plate dimensions, bolt positions, load information etc. were entered in the user input field on the module. Factor of safety condition was set as 3. This condition works with a tolerance range of +0.3. Accordingly, the results for the factor of safety range of 3-3.3 are given as output.

By pressing the “CALCULATE” button, the calculation process for the bolted joint was done automatically. The optional results found for the design are listed in the “Optional Results” subsection of the “RESULTS” section. In order to find the optimum results for the design, preferences were made in the optimization section. For the priority state, levels 1, 2 and 3 were selected as safety, diameter and strength constraints, respectively. Min-max conditions were assigned to these constraints and the constraint-conditions are as follows: “safety-max, diameter-min and strength-max”. For the first (1st) priority safety constraint and maximum condition, filtering is applied so that the results with the highest factor of safety from the design options remain. For the second (2nd) priority diameter constraint and minimum condition, the results with the lowest bolt diameter size are filtered from the remaining results. For the third and last (3rd) priority strength constraint and maximum condition, the optimum results for the design with the bolt with the highest yield strength are determined from the remaining results. The optimization

settings were applied by pressing the “OPTIMIZE” button. The optimum results were given as output in the “Optimum Results” subsection. The optimum results for the bolted joint design were found as M22 bolt,

grade 10.9, yield strength of 900 MPa and factor of safety with a value of 3.187. An example application for the software is given in Figure 16.

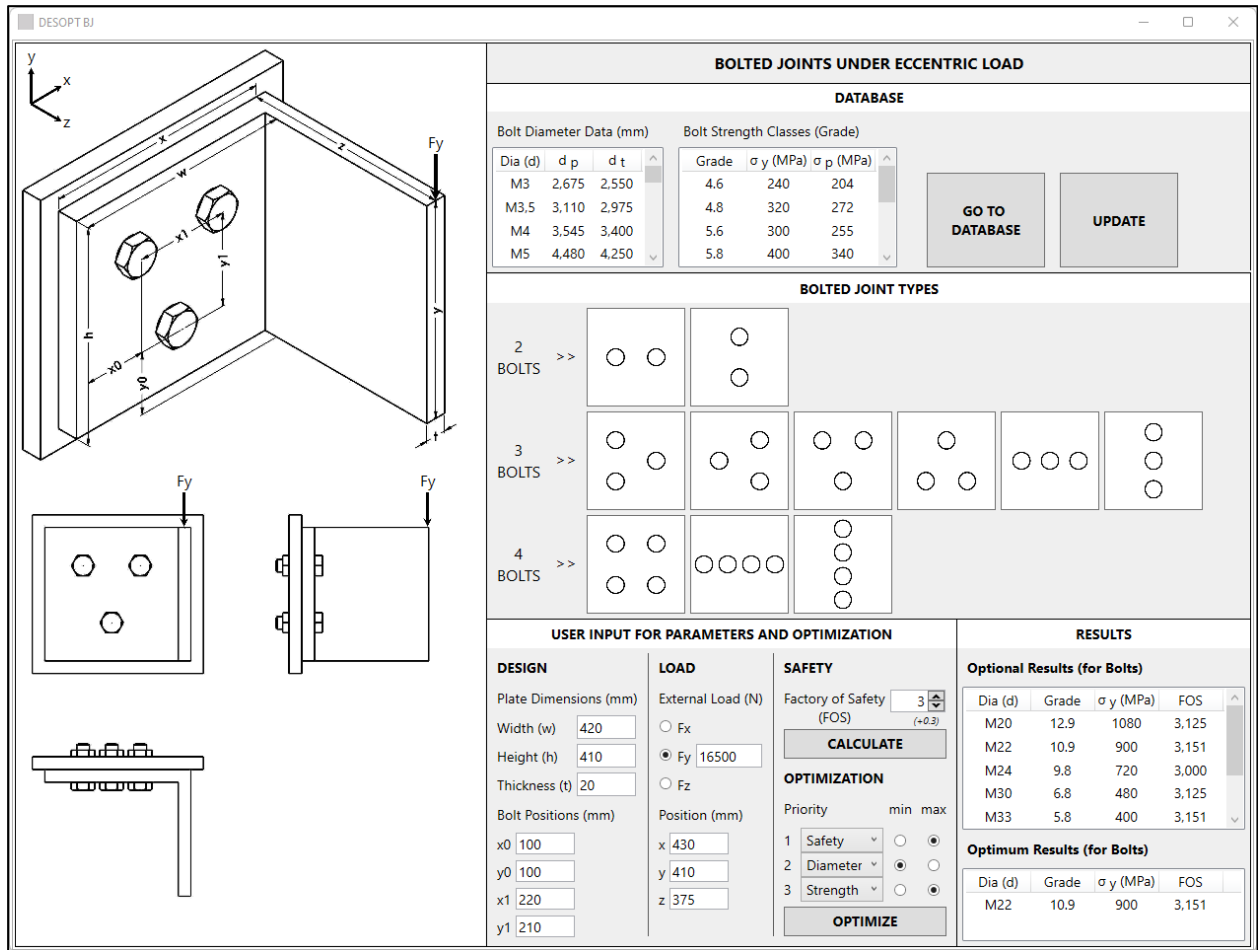

Figure 16. Example application for software

Theoretical solutions were performed for the optimum design results found through the sample bolted joint application.

The general process for the example bolted joint is described below, followed by the detailed solution.

General Process

Under the influence of the load applied to the joint, the bolts are subjected to a direct force and primary shear forces are generated. Due to the eccentricity of the load, a torsional moment occurs with the center of gravity of the bolt group at the point of rotation, resulting in secondary shear forces. By combining the primary and secondary shear forces, the ultimate shear forces on the bolts are found. In addition, as the applied load is perpendicular to the bolt axis, a bending moment occurs, resulting in tensile forces in the bolts. The preloaded bolted joint carries part of the load. In all cases, the ultimate stress is calculated and the factor of safety of the joint is found.

Theoretical Solution

Primary shear forces directly on the bolts

$$F_{s1} = \frac{F_y}{n} \tag{36}$$

$$F_{s1} = \frac{16\ 500}{3} \Rightarrow F_{s1} = 5\ 500\ N \tag{37}$$

Centre of gravity of the bolt group

$$x_c = \frac{x_1 * A_1 + x_2 * A_2 + x_3 * A_3}{A_1 + A_2 + A_3} \tag{38}$$

$$y_c = \frac{y_1 * A_1 + y_2 * A_2 + y_3 * A_3}{A_1 + A_2 + A_3} \tag{39}$$

Since the bolt diameters are equal, the bolt cross-sectional areas are equal.

$$A_1 = A_2 = A_3 = A \tag{40}$$

The “A” expressions for different bolts in the equations are equalized.

$$x_c = \frac{x_1 * A + x_2 * A + x_3 * A}{A + A + A} \quad (41)$$

$$y_c = \frac{y_1 * A + y_2 * A + y_3 * A}{A + A + A} \quad (42)$$

In the equations, the area (A) is written as a common expression.

$$x_c = \frac{(x_1 + x_2 + x_3) * A}{3 * A} \quad (43)$$

$$y_c = \frac{(y_1 + y_2 + y_3) * A}{3 * A} \quad (44)$$

The "A" expressions are simplified and the final form of the equations is as follows.

$$x_c = \frac{x_1 + x_2 + x_3}{3} \quad (45)$$

$$y_c = \frac{y_1 + y_2 + y_3}{3} \quad (46)$$

The bolt positions are substituted in the equation and the center of gravity is calculated.

$$x_c = \frac{110 + 0 + 220}{3} \Rightarrow x_c = 110 \text{ mm} \quad (47)$$

$$y_c = \frac{0 + 210 + 210}{3} \Rightarrow y_c = 140 \text{ mm} \quad (48)$$

Moment generation

$$M = F_y * e \quad (49)$$

$$M = 16\,500 * 220 \Rightarrow M = 3\,630\,000 \text{ Nmm} \quad (50)$$

Radius from the center to the bolts

$$r_i = \sqrt{r_{x_i}^2 + r_{y_i}^2} \quad (51)$$

$$r_1 = \sqrt{r_{x_1}^2 + r_{y_1}^2} \Rightarrow r_1 = \sqrt{0 + 140^2} \quad (52)$$

$$r_1 = 140 \text{ mm}$$

$$r_2 = \sqrt{r_{x_2}^2 + r_{y_2}^2} \Rightarrow r_2 = \sqrt{110^2 + 70^2} \quad (53)$$

$$r_2 = 130.384 \text{ mm}$$

$$r_3 = \sqrt{r_{x_3}^2 + r_{y_3}^2} \Rightarrow r_3 = \sqrt{110^2 + 70^2} \quad (54)$$

$$r_3 = 130.384 \text{ mm}$$

$$\sum r^2 = r_1^2 + r_2^2 + r_3^2 \quad (55)$$

$$\sum r^2 = 140^2 + 130.384^2 + 130.384^2 \quad (56)$$

$$\sum r^2 = 53\,599.975 \text{ mm}^2$$

Secondary shear forces due to moment effect

$$F_{s2x_i} = \frac{M * r_{y_i}}{\sum r^2} \quad (57)$$

$$F_{s2y_i} = \frac{M * r_{x_i}}{\sum r^2} \quad (58)$$

$$F_{s2x_1} = \frac{3\,630\,000 * 140}{53\,599.975} \quad (59)$$

$$F_{s2x_1} = 9\,481.348 \text{ N}$$

$$F_{s2y_1} = \frac{3\,630\,000 * 0}{53\,599.975} \quad (60)$$

$$F_{s2y_1} = 0 \text{ N}$$

$$F_{s2x_2} = \frac{3\,630\,000 * 70}{53\,599.975} \quad (61)$$

$$F_{s2x_2} = 4\,740.673 \text{ N}$$

$$F_{s2y_2} = \frac{3\,630\,000 * 110}{53\,599.975} \quad (62)$$

$$F_{s2y_2} = 7\,449.630 \text{ N}$$

$$F_{s2x_3} = \frac{3\,630\,000 * 70}{53\,599.975} \quad (63)$$

$$F_{s2x_3} = 4\,740.673 \text{ N}$$

$$F_{s2y_3} = \frac{3\,630\,000 * 110}{53\,599.975} \quad (64)$$

$$F_{s2y_3} = 7\,449.630 \text{ N}$$

Total shear forces and combined shear forces with respect to axes (x and y)

$$F_{s_{x_i}} = F_{s2x_i} \quad (65)$$

$$F_{s_{y_i}} = F_{s1} + F_{s2y_i} \quad (66)$$

$$F_{s_i} = \sqrt{F_{s_{x_i}}^2 + F_{s_{y_i}}^2} \quad (67)$$

$$F_{s_{x_1}} = F_{s2x_1} \Rightarrow F_{s_{x_1}} = 9\,481.348 \text{ N} (-) \quad (68)$$

$$F_{s_{y_1}} = F_{s1} + F_{s2y_1}$$

$$F_{s_{y_1}} = -5\,500 + 0 \quad (69)$$

$$F_{s_{y_1}} = 5\,500 \text{ N} (-)$$

$$F_{s_1} = \sqrt{\sum F_{s_{x_1}}^2 + \sum F_{s_{y_1}}^2} \quad (70)$$

$$F_{s_1} = \sqrt{9\,481.348^2 + 5\,500^2}$$

$$F_{s_1} = 10\,961.111 \text{ N}$$

$$F_{s_{x_2}} = F_{s2x_2} \Rightarrow F_{s_{x_2}} = 4\,740.673 \text{ N} \quad (71)$$

$$F_{s_{y_2}} = F_{s1} + F_{s2y_2}$$

$$F_{s_{y_2}} = -5\,500 + 7\,449.630 \quad (72)$$

$$F_{s_{y_2}} = 1\,949.630 \text{ N}$$

$$F_{s2} = \sqrt{F_{sx2}^2 + F_{sy2}^2}$$

$$F_{s2} = \sqrt{4\,740.673^2 + 1\,949.630^2}$$

$$F_{s2} = 5\,125.918\,N$$
(73)

$$F_{sx3} = F_{s2x3} \Rightarrow F_{sx3} = 4\,740.673\,N$$
(74)

$$F_{sy3} = F_{s1} + F_{s2y3}$$

$$F_{sy3} = -5\,500 - 7\,449.630$$

$$F_{sy3} = 12\,949.630\,N(-)$$
(75)

$$F_{s3} = \sqrt{F_{sx3}^2 + F_{sy3}^2}$$

$$F_{s3} = \sqrt{4\,740.673^2 + 12\,949.630^2}$$

$$F_{s3} = 13\,790.101\,N$$
(76)

Tensile force on bolts

$$F_{ti} = \frac{F_y * z * l_i}{l_1^2 + l_2^2 + l_3^2}$$
(77)

$$F_{t1} = \frac{16\,500 * 375 * 100}{100^2 + 310^2 + 310^2}$$

$$F_{t1} = 3\,060.089\,N$$
(78)

$$F_{t2} = \frac{16\,500 * 375 * 310}{100^2 + 310^2 + 310^2}$$

$$F_{t2} = 9\,486.276\,N$$
(79)

$$F_{t3} = \frac{16\,500 * 375 * 310}{100^2 + 310^2 + 310^2}$$

$$F_{t3} = 9\,486.276\,N$$
(80)

Joint stiffness constant

$$C = \frac{k_b}{k_b + k_m}$$
(81)

A good joint consists of stiff components and elastic bolts. In a well-designed hard joint, the components are rigid $k_m \gg k_b$, that is $k_m \geq 3 * k_b$. The effective stiffness of the clamped elements is assumed to be $k_m = 3 * k_b$ [26, 31-34].

$$C = \frac{k_b}{k_b + (3 * k_b)}$$
(82)

$$C = \frac{k_b}{4 * k_b}$$
(83)

$$C = \frac{1}{4}$$
(84)

$$C = 0.25$$
(85)

Friction force and normal force (contact force)

$$F_f = \mu * N$$
(86)

$$F_s = \mu * N$$
(87)

$$N = \frac{F_s}{\mu}$$
(88)

$$N_i = \frac{F_{si}}{\mu}$$
(89)

The coefficient of friction (μ) varies according to factors such as material type, dry, wet or lubricated material surfaces. The coefficient of friction is generally taken as 0.2 for materials such as steel and cast iron [26]. This is the general acceptance.

$$N_1 = \frac{F_{s1}}{\mu} \Rightarrow N_1 = \frac{10\,961.111}{0.2}$$

$$N_1 = 54\,805.555\,N$$
(90)

$$N_2 = \frac{F_{s2}}{\mu} \Rightarrow N_2 = \frac{5\,125.918}{0.2}$$

$$N_2 = 25\,629.590\,N$$
(91)

$$N_3 = \frac{F_{s3}}{\mu} \Rightarrow N_3 = \frac{13\,790.101}{0.2}$$

$$N_3 = 68\,950.505\,N$$
(92)

Clamp load on joined members

$$F_m = -N$$
(93)

$$F_{mi} = -N_i$$
(94)

$$F_{m1} = -N_1 \Rightarrow F_{m1} = -54\,805.555\,N$$
(95)

$$F_{m2} = -N_2 \Rightarrow F_{m2} = -25\,629.590\,N$$
(96)

$$F_{m3} = -N_3 \Rightarrow F_{m3} = -68\,950.505\,N$$
(97)

Preload status

$$F_m = F_t * (1 - C) - F_i$$
(98)

$$F_i = F_t * (1 - C) - F_m$$
(99)

$$F_{i_i} = F_{t_i} * (1 - C) - F_{m_i}$$
(100)

$$F_{i1} = 3\,060.089 * (1 - 0.25) - (-54\,805.555)$$

$$F_{i1} = 57\,100.622\,N$$
(101)

$$F_{i2} = 9\,486.276 * (1 - 0.25) - (-25\,629.590)$$

$$F_{i2} = 32\,744.297\,N$$
(102)

$$F_{i3} = 9\,486.276 * (1 - 0.25) - (-68\,950.505)$$

$$F_{i3} = 76\,065.212\,N$$
(103)

Force on the bolts (due to preload and external load)

$$F_b = F_t * C + F_i$$
(104)

$$F_{b_i} = F_{t_i} * C + F_{i_i}$$
(105)

$$F_{b1} = 3\,060.089 * 0.25 + 57\,100.622$$

$$F_{b1} = 57\,865.644\,N$$
(106)

$$F_{b_2} = 9\,486.276 * 0.25 + 32\,744.297$$

$$F_{b_2} = 35\,115.866\,N \quad (107)$$

$$F_{b_3} = 9\,486.276 * 0.25 + 76\,065.212$$

$$F_{b_3} = 78\,436.781\,N \quad (108)$$

$$F_{b_{max}} = F_{b_3} = 78\,436.781\,N \quad (109)$$

Maximum stress

$$\sigma_{max} = \frac{F_{b_{max}}}{A_t} \quad (110)$$

$$A_t = \frac{\pi * d_t^2}{4} \quad (111)$$

$$A_t = \frac{\pi * 18.700^2}{4}$$

$$A_t = 274.646\,mm^2 \quad (112)$$

$$\sigma_{max} = \frac{78\,436.781}{274.646} \quad (113)$$

$$\sigma_{max} = 285.592\,MPa$$

Factor of Safety (FOS)

$$S (FOS) = \frac{\sigma_y}{\sigma_{max}} \quad (114)$$

$$S = \frac{900}{285.592} \quad (115)$$

$$S = 3.151 \quad (116)$$

Theoretical solutions for the design parameters given within the scope of the sample bolted joint and the optimum results including 10.9 quality M22 bolts were made and found to be compatible with the application realized in the software. In the theoretical solution, the factor of safety was calculated as 3.151 as the final result. The factor of safety was also calculated as 3.151 in the software application. As a result, it was seen that the theoretical solutions and the outputs obtained with the software were 100% compatible. It was concluded that safe results were produced with the developed software.

4. RESULTS AND DISCUSSION

In this study, a software for analysis-based design and optimization of bolted joints under eccentric load was developed and the process was automated. The software receives inputs for the selected type of joint and finds optional and optimum results for each data in the database. The software results and the theoretical solutions were compared and it was concluded that they provide a strong compatibility.

The results obtained with the software developed in this study are given below.

- In today's design and analysis programs, the slowness of the processes, the complexity and laboriousness of the manual operations, and the design-analysis cycles to achieve the targeted conditions lead to a large workforce and a large amount of time loss. With the software developed, the design and optimization of bolted joints was carried out automatically according to the targeted conditions. In this way, the optimum bolted joint design was achieved in one go, avoiding the design-analysis cycle, saving workload and time.
- With the real-time software, calculations and operations were performed instantaneously. Compared to manual solutions and the long time it takes to design and analyze in other existing software, the results were reached instantly with the software developed. In this way, a significant amount of time was saved.
- Thanks to the software's practical structure and ability to work with minimal user input, the workload was minimized.
- Without being limited to a single design, calculations were made for different design options at once and optimum bolted joints were realized. The software, which has a flexible structure, offers users a wide range of designs.
- With the interactive database system, design and optimization can be performed according to special conditions and situations.
- A graphical user interface was designed for the software, which is not common in the studies in the literature, and interaction, visualization and convenience were provided.
- The developed software can effectively perform the design and optimization of bolted joints of various types and designs under different load conditions in a short time thanks to the interactive interface and can be used as a tool to increase productivity.

Based on this study, the following topics can be studied in the future.

- Studies and systems can be developed for the design, analysis and optimization of bolted joints subjected to complex loads.
- The scope can be extended with different environments and conditions, various methods and mathematical models can be applied.
- Joining methods such as riveted joints, welded joints, etc. can be studied.
- Different optimization techniques such as topology optimization can be added to provide different perspectives.

DECLARATION OF ETHICAL STANDARDS

The author(s) of this article declare that the materials and methods used in this study do not require ethical committee permission and/or legal-special permission.

AUTHORS' CONTRIBUTIONS

Kadir SARI: He came up with the idea, did the research, created the design, developed the software, analyzed the results and wrote the paper.

Hakan DİLİPAK: He managed the process, checked the study, evaluated the results and reviewed the manuscript.

CONFLICT OF INTEREST

There is no conflict of interest in this study.

REFERENCES

- [1] Gunantara N., "A review of multi-objective optimization: Methods and its applications", *Cogent Engineering*, 5(1): 1502242, (2018).
- [2] Nakagome M., Suzukı I., Yasuda K. and Mızuno M., "On the compliance and the load factor of bolted connections subjected to eccentric loading", *JSME international journal., Ser. I, Solid mechanics, strength of materials*, 32(1): 61-66, (1989).
- [3] Bogis H. A., Abou Ezz A., Akyurt M. and Alghamdi A. A. A., "An interactive software for the design of power screws", *Proc. STCEX*, Riyadh, Saudi Arabia, 197-202, (2002).
- [4] Padhi G.S., McCarthy M.A. and McCarthy C.T., "BOLJAT: a tool for designing composite bolted joints using three-dimensional finite element analysis", *Composites Part A: Applied Science and Manufacturing*, 33(11): 1573-1584, (2002).
- [5] Özkan M.T., "Cıvatalı bağlantılarda birleştirilen elemanların direngenliğinin sonlu elemanlar yöntemi ve yapay sinir ağları sistemi ile belirlenmesi ve civata tasarımı", *PhD Thesis, Gazi University Graduate School of Natural and Applied Sciences*, (2003).
- [6] Bogis H.A., Abou Ezz A., Aljinaidi A.A. and Akyurt M., "Bolted joints an interactive software", *Seventeenth National Conference for Computer*, Medina, Saudi Arabia, 125-139, (2004).
- [7] Bogis H.A., Abou Ezz A., Aljinaidi A.A. and Akyurt M., "Computer-aided design of riveted and bolted joints under compound loading", *Seventeenth National Conference for Computer, Medina*, Saudi Arabia, 309-321, (2004).
- [8] Bogis H.A., Abou Ezz A., Aljinaidi A.A. and Akyurt M., "An interactive software for the design of riveted joints". *Seventeenth National Conference for Computer*, Medina, Saudi Arabia, 155-173, (2004).
- [9] Bogis H.A., Abou Ezz A., Aljinaidi A.A. and Akyurt M., "An interactive software for the design of welded joints". *Seventeenth National Conference for Computer*, Medina, Saudi Arabia, 175-189, (2004).
- [10] Gray P.J. and McCarthy C.T., "A global bolted joint model for finite element analysis of load distributions in multi-bolt composite joints", *Composites Part B: Engineering*, 41(4): 317-325, (2010).
- [11] Zhang B., Brown D., Pierre J.S., Tao X., Williams I., Whitehead G., Wolfe C. and Pillutla R., "Multi-objectives optimization of fastener location in a bolted joint", *SAE 2013 World Congress & Exhibition*, Michigan, United States, 2013-01-0966, (2013).
- [12] Wankhade A.P. and Jadhao K.K., "Design and analysis of bolted joint in composite laminated", *Journal of Modern Engineering Research (IJMER)*, 4(3): 20-24, (2014).
- [13] Adeyeri M.K., "Development of software for riveted joints design", *Journal of Multidisciplinary Engineering Science and Technology (JMEST)*, 3(3): 4370-4380, (2016).
- [14] Sanlı T.V., "Development of artificial neural network based design tool for aircraft engine bolted flange connection subject to combined axial and moment load", *MSc Thesis, Middle East Technical University Graduate School of Natural and Applied Science*, (2018).
- [15] Özüğurlu D.C., "Yapay sinir ağları yardımıyla titreşim altındaki cıvataların gevşeme tahmini", *MSc Thesis, Ege University Graduate School of Natural and Applied Sciences*, (2019).
- [16] Turgaç A.T., "İçten yanmalı motorlarda biyel kolu cıvatalarının hesabına ve tasarımına yönelik yazılım geliştirme", *PhD Thesis, İstanbul Technical University Graduate School of Natural and Applied Sciences*, (2020).
- [17] Rakotondrainibe L., Desai J., Orval P. and Allaire G., "Coupled topology optimization of structure and connections for bolted mechanical systems", *European Journal of Mechanics-A/Solids*, 93: 104499, (2022).
- [18] Jiang K., Liang Y. and Zhao O., "Machine-learning-based design of high strength steel bolted connections", *Thin-Walled Structures*, 179: 109575, (2022).
- [19] Sevinç S. and Taşkın M., "Numerical analysis of single lap pretension bolted joint", *International Journal of Engineering and Applied Sciences*, 14 (3): 77-90, (2023).
- [20] Sarı K., Kayır Y. and Dilipak H., "An expert system for bolt selection", *Bilişim Teknolojileri Dergisi*, 16(2), 83-9: (2023).
- [21] Sarı K. and Dilipak H., "Yanal yük altındaki cıvatalı bağlantıların tasarımı ve optimizasyonu için bir yazılım geliştirme", *4. Uluslararası Hasankeyf Bilimsel Araştırmalar ve İnovasyon Kongresi*, Batman, Türkiye, 419-429. (2023).
- [22] Sarı K. and Dilipak H., "A design software based on the placement of bolts for bolted joints", *Artvin Çoruh Üniversitesi Mühendislik ve Fen Bilimleri Dergisi*, 1(2): 104-114, (2023).
- [23] Sarı K. and Dilipak H., "A software for optimum design of laterally loaded bolted joints", *Gazi University Journal of Science Part C: Design and Technology*, 12(1): 366-377, (2024).
- [24] Juvinall R.C. and Marshek K.M., "Fundamentals of machine component design", *John Wiley & Sons*, New Jersey, USA, (2011).
- [25] Budynas R.G. and Nisbett J.K., "Shigley's mechanical engineering design", *McGraw-Hill*, New York, ABD, (2015).
- [26] Collins J.A., Busby H.R. and Staab G.H., "Mechanical design of machine elements and machines: a failure prevention perspective", *John Wiley & Sons*, New Jersey, USA, (2009).

- [27] **Rajagiri School of Engineering & Technology (RSET)**, “Design of machine elements”, https://www.rajagiritech.ac.in/home/mech/Course_Content/Semester%20VII/ME%20401%20Design%20of%20Machine%20Elements%20I/Module%203.pdf
- [28] Khurmi R.S. and Gupta J.K., “**A textbook of machine design**”, S. Chand, New Delhi, India, (2005).
- [29] Bickford J.H., “Introduction to the design and behavior of bolted joints: non-gasketed joints”, **CRC press**, Florida, ABD, (2007).
- [30] ISO 898-1, “Mechanical properties of fasteners made of carbon steel and alloy steel”, (2013), <https://www.iso.org/obp/ui/#iso:std:iso:898:-1:ed-5:v1:en>
- [31] Yahr G.T., “Preloading of bolted connections in nuclear reactor component supports”, No. NUREG/CR-3853: ORNL-6093, **Oak Ridge National Laboratory (ORNL)**, Tennessee, United States, (1984).
- [32] Polak T.A., “**Machine elements in mechanical design**”, Pearson, New York, ABD, (2018).
- [33] Childs P.R., “Mechanical design”, Elsevier Butterworth-Heinemann, **Jordan Hill**, Oxford, (2004).
- [34] University of Nottingham, “**Design and analysis of bolted joints**”, https://notes.alv.cx/notes/uni/mmme/2044_design_manufacture_and_project/lecture_slides/Lecture%208%20Bolted%20joints_v1.1.pdf