

## GEOLOGY AND MINERALOGY OF THE BİGADIÇ BORATE DEPOSITS AND VICINITY

Cahit HELVACI\* and Orhan ALACA\*\*

**ABSTRACT.** - In the Bigadiç volcano-sedimentary basin, Palaeozoic-Mesozoic basement rocks are overlain unconformably by the Miocene rock units. The stratigraphic sequence of Miocene units, from the bottom to the top in ascending order is, basement volcanic unit, basement limestone unit, lower tuff unit, lower borate bearing unit, upper tuff unit, upper borate bearing unit, and basalt unit. Miocene units are overlain unconformably by the recent sediments, and alluvium rests unconformably on the recent sediments. In the region, Palaeozoic and Mesozoic basement rocks were subjected to block faulting and dislocation during the pre-Miocene. As a result of these movements, large and small sized several playa lake type sedimentation basins were formed, and Miocene sediments were deposited in these basins. In the study area, the general strike of the fold axis is NE-SW. Beds generally dip towards MW or SE with 5°-35°. Borate deposits occur as two different horizons in the upper and lower borate bearing units, which are separated from each other by the upper tuff unit. In the region, the lower and upper borate zones show thickness varying between 35-130 meters and 20-110 meters, respectively. Boron ores are alternated with claystone, mudstone, tuff and thin-bedded limestone, and generally exhibit lenticular structures. Colemanite and ulexite are the dominant ore minerals in both of the ore zones. In addition to these, other boron minerals such as pandermite, probertite, howlite, tunellite, meyerhoffite, hydroboracite and inyoite have also been determined in the basin. Colemanite in the lower and upper borate zones have possibly precipitated directly from the solutions contemporaneous with sedimentation, within the unconsolidated sediments under the sediment/water interface. Nodules continued to develop, parallel to the compaction of sediments. Formation of ulexite resembles that of colemanite and it reflects the period when Na-concentration of the solution has increased.

### INTRODUCTION

Bigadiç town, located on the Balıkesir-İzmir highway, about 37 km. to Balıkesir, is the biggest residential center within the investigated area (Fig. 1).

After the discovery of borate deposits around Bigadiç in 1950, various studies were carried out by different investigators (Meixner, 1952, 1953, 1956; Helke, 1955; Bekişoğlu, 1961; Kutlu, 1963; Kalafatçioğlu, 1964; Özpeker, 1969; Borsi et al., 1972; Yılmaz, 1977). More recent studies in the area are given below:

1- Çakır and Dündar (1982), prepared the 1:25.000 scale geological map of the area, and determined that borate was deposited as two separate zones, contrary to the former acception of a single ore zone; 2- Gündoğdu (1982), determined the stratigraphic sequence of the basin, and carried out detailed mineralogic and geochemical investigations on the individual rock units; 3- Helvacı (1983), realized the correlation of Turkish borate deposits to the world deposits, and determined the common characteristics of the Turkish borate deposits. In addition, characteristics of boron minerals constituting the borate deposits and their mineralogic features are presented in detail; 4- Helvacı and Alaca (1984), give a survey of the geology of Bigadiç borate deposit and explain the mode of occurrence of borate minerals determined at the area; 5- Helvacı and Dora (1985), explain the howlite and tunellite formation phases at Bigadiç borate deposits; 6- Helvacı et al. (1987), review the geology of Turkish borate deposits in a survey of the stratigraphy and economic potential of West Anatolian Neogene sediments. Also general features of the depositional environments are presented by the correlation of stratigraphic sequences of various borate deposits; 7- Alaca et al. (1987), have carried out the geological exploration of western section of the Bigadiç borate basin.

This present study aims to cover distinguishing the stratigraphic units at the Bigadiç volcano-sedimentary basin and its close vicinity; a detailed investigation of the borate bearing units; determination of the boron minerals within the borate deposits, and ore grades.

### STRATIGRAPHY

Basement rocks, comprising Palaeozoic schist and marble, and Mesozoic ophiolitic rocks, limestone, radiolarite and sandstone are overlain unconformably by the Neogene volcanic and volcano-sedimentary rocks in the study area (Fig. 2).

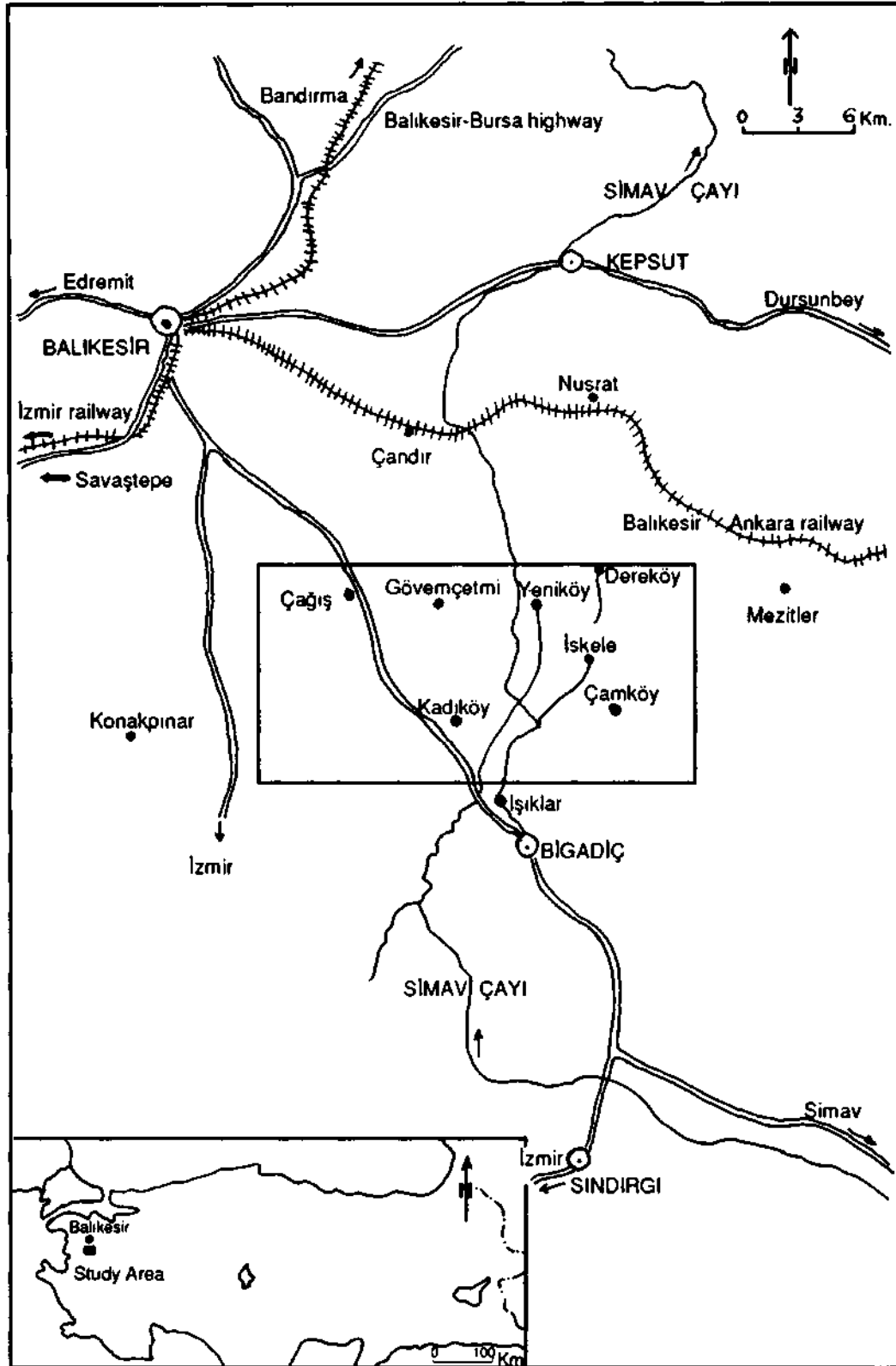

Fig. 1 - Location map of Bigadiç basin.

| GEOLOGICAL TIME |               |                |                       | THICKNESS (m.)        | LITHOLOGY      | EXPLANATIONS   |   |                           |
|-----------------|---------------|----------------|-----------------------|-----------------------|----------------|--|---|---------------------------|
| ERA SYSTEM      | SYSTEM        | SERIES         | STAGE                 |                       |                |  |   |                           |
| CENOZOIC        | QUATERNARY    |                |                       | 0 - 70                |                | Gravel, sand, silt   | ALLUVIUM  |                           |
|                 |               |                |                       | 5 - 180               |                | Claystone<br>Sandstone<br>Conglomerate                                   | RECENT FLUVIAL SEDIMENTS  |                           |
|                 | NEOGENE       | UPPER MIOCENE  | UPPER/LOWER PANNONIAN | 20 - 110              |                | BASALT   |   |                           |
|                 |               |                |                       | Ore Zone 0.10 - 80.00 |                | Borate zon, claystone, marl, limestone, tuff                             | UPPER BORATE BEARING UNIT   |                           |
|                 |               |                |                       | 90 - 410              |                | Fine-grained tuff<br>Coarse-grained tuff                                 | UPPER TUFF UNIT   |                           |
|                 |               | LATE PANNONIAN | 35 - 130              | Ore Zone 0.20 - 76.00 |                | Borate zone, marl, claystone, clayey limestone, mudstone, tuff           |   | LOWER BORATE BEARING UNIT |
|                 |               |                |                       |                       |                | 100 - 150  | atg : Lacustrine lower tuff<br>atk : Continental lower tuff<br>atkk : Coal facies | LOWER TUFF UNIT           |
|                 |               | MIDDLE MIOCENE |                       |                       |                | Limestone, claystone, tuff, marl, dolomite                               |   | LOWER LIMESTONE UNIT      |
|                 | 50 - 90       |                |                       |                       |                |  |   |                           |
|                 | LOWER MIOCENE |                |                       | 250 +                 |                | Basalt, andesite, trachy-andesite, trachycite, dacite, tuff, agglomerate |   | BASEMENT VOLCANIC UNIT    |
|                 |               |                |                       |                       |                |  |   |                           |
|                 | MESO          |                |                       |                       |                | Ophiolite, limestone, radiolarite, sandstone                             |   | BASEMENT ROCKS            |
| PALEO           |               |                |                       |                       | Schist, marble |  |   |                           |

Fig. 2 - Generalized stratigraphic column of Bigadiç region.

Neogene volcanic and volcano-sedimentary rocks have been classified from bottom to top as: basement volcanic unit, basement limestone unit, lower tuff unit, lower borate bearing unit, upper tuff unit, upper borate bearing unit and basalt.

Recent sediments of Quaternary and actual alluvial deposits overlie the Neogene lithologic units unconformably in the study area. Geological map of the study area is given in Figure 3.

## PALAEOZOIC AND MESOZOIC

### Basement rocks

Palaeozoic rocks (schist, marble) and Mesozoic rocks (ophiolitic rocks, limestone, radiolarite, sandstone) have been distinguished as the basement rocks in the study area.

The green and grayish-blue schists are in albite-sericite and chlorite-epidote-muscovite composition. Marbles are usually fine-crystalline and occur in alternation with schists.

Peridotites are mostly serpentinized. Tale alteration is frequently observed within these light to dark green colored rocks.

Limestones, which are dark gray and occasionally black in color, contain abundant fractures. Coarse-grained calcite minerals exhibit cleavage in two directions and pressure-twins, and some bear iron oxide, calcite and occasional quartz fillings in the fractures.

Radiolarite is composed of spherical radiolaria fragments bound together with cryptocrystalline quartz and limonite. Color is dark brown.

Sandstone comprises quartz, feldspar, muscovite, calcite and opaque minerals, whose grain size varies between 0.05 and 0.2 mm. This rock is badly sorted and graded. Color is dark gray and greenish.

Basement rocks are overlain by the basement volcanic unit in the study area. To the north of Güvemçetmi village, lower borate bearing unit overlies the basement rocks. Unconformity exists between the basement rocks and the overlying units.

## CENOZOIC

### Neocene units

*Basement volcanic unit.* – The lithologic unit comprising greenish-gray, gray, pink, greenish-black colored andesite, basalt, trachyandesite, trachyte, dacite, agglomerate and tuff has been distinguished as the basement volcanic unit.

Fresh surfaces of the basalt are greenish-black colored, while the altered parts show reddish-brown color. Pyroxene minerals can be distinguished when examined carefully with naked eye. Plagioclase and opaque minerals have been determined in the rock. Plagioclase is idiomorphic to hypidiomorphic, sometimes having a zoned structure, and is composed of labrador with 55 % An. Polysynthetic twins are common. Augite is hypidiomorphic and coarsely crystalline.

Dominant color of andesite is pinkish, and feldspars and biotites are distinguishable with the naked eye. The rock components are biotite, hornblende, feldspar and quartz phenocrysts in a calcified and clayey vitreous cement. Feldspars contain albite type twins and the composition is close to oligoclase with 25 % An. Most common mafic mineral is biotite with typical cleavage in one direction. Hornblende crystals are rare. Chloritized parts of spherulitic texture are occasionally observed in the matrix.

Dacitic rocks in the area generally exist together with tuff and agglomerate. These rocks are whitish, gray, pale-green but mostly light colored. Tuff predominated parts show obvious erosional influence. Flow-structure is characteristic for dacite which composes of quartz, feldspar, mica and amphibole minerals. Hyalopilitic texture is also observed in thin sections. Feldspar, biotite, quartz and to a lesser extent hornblende microliths occur as floating in a vitreous matrix, showing both flow structure and crystalline structure. Feldspars are mostly in oligoclase-andesine composition. Quartz crystals are coarse



Fig. 3 - Geological map of Bigadiç borate basin and vicinity.

grained. Cleavage surfaces and edges of biotite show opacity due to alteration. The rock bears very little amount of opaque minerals.

Trachytic rocks at the area also occur together with tuff and agglomerate. These rocks are dirty yellow to grayish colored and are composed of euhedral and subhedral sanidine crystals of 3-4 cm., in a vitreous and crystalline matrix.

Trachyandesites occasionally occur together with trachytes and comprise plagioclase, biotite and hornblende phenocrystals floating in a vitreous matrix, and random quartz crystals. Plagioclase is in oligoclase-andesine composition. Partial chloritization is observed in the matrix, and opaque parts on hornblende and biotite. Scarce and fine-grained opaque minerals are distributed in the matrix.

Tuff and agglomerate of volcanic rocks in the region exist in various amounts together with these rocks. Tuffs are generally composed of a fine-grained vitreous matrix and abundant feldspar, quartz and biotite crystals within the matrix. Plagioclase is represented by albite, oligoclase and andesine. Some clay minerals are observed due to the alteration of tuff. Agglomerates are made up of andesite and dacite fragments, and cemented by tuff. Pebbles are rounded and sometimes angular, and tuffaceous horizons are found as interbeds.

Hot water springs are present in andesite-trachyte at Hisarköy, in the east of the study area. Water samples from these springs yielded 10 ppm B. Hotness of water is about 90°C.

Basement volcanic unit overlies the basement rocks unconformably. On the other hand, this unit itself is generally overlain unconformably by the basement limestone unit. In some places (e.g. around Yeniköy) lower borate bearing unit directly lies over the limestone unit.

Age of the basalt cropping out at Kocakır Tepe within this unit was determined to be 17 million years, by the K-Ar method (Yılmaz, 1977).

*Basement limestone unit.* -This unit, which is composed of white, yellowish white, green, creamy and beige colored, thin bedded and laminated marl, limestone, claystone, dolomitic limestone and tuff, forms gentle slopes in the study area.

The unit starts with whitish creamy colored, thin bedded dolomitic limestone, with abundant cracks and fractures. Over this lies a platy limestone-marl alternation with tuff bands. An alternation of claystone-limestone-tuff-marl constitutes the uppermost section of the unit.

Limestones at the lower section of the unit generally exhibit micritic and locally sparitic character. Thickness of beds range among 5-40 cm. Fractures and solution cavities are common, and sometimes filled by calcite. Tuffs are yellowish green in color and are composed of volcanic ash.

Basement limestone unit rests on the basal volcanic unit unconformably. Lower tuff unit overlies conformably, at the upper contact.

Samples for palynologic investigation were collected from the clayey horizons within the unit, but they were sterile and contained no pollens suitable for age determination (Akgün, 1985).

Presence of tuff bands in the unit indicate that volcanic activity was continuing during the sedimentation of the unit. Presence of dolomitic limestone in the lower levels show that chemical sedimentation started in the playa lakes which started developing at the beginning of Lower Miocene with the transportation of epiclastic and pyroclastic material into the basin middle and upper levels of the unit sedimented consecutively.

*Lower tuff unit.* - This yellowish white to dark gray colored unit has generated in relation to the active volcanism around the lacustrine basins. Successively, terrestrial and lacustrine phases have developed.

Fresh surfaces of the lacustrine facies samples of the unit are dark gray colored, and abundant biotite, feldspar and quartz grains can be distinguished by naked eye. Samples from the lower tuff unit in lacustrine facies yield abundant feldspar, quartz, biotite and rare hornblende, in addition to a little amount of volcanic fragments, usually occurring in a vitreous matrix. Tuffs in lacustrine facies contain zeolite minerals (clinoptilolite and heulandite).

Lower tuff unit in terrestrial facies is well exposed around the Köteyli village, to the north of Balıkesir province, outside the investigated area (Figs. 4 and 5). Samples from this location has been described as andesitic crystalline tuff, by petrographic studies. Cement of the rock comprise volcanic components together with plagioclase microliths in a lesser extent, which are ash sized. Opaque minerals such as hornblende and biotite have also been determined in the rock.

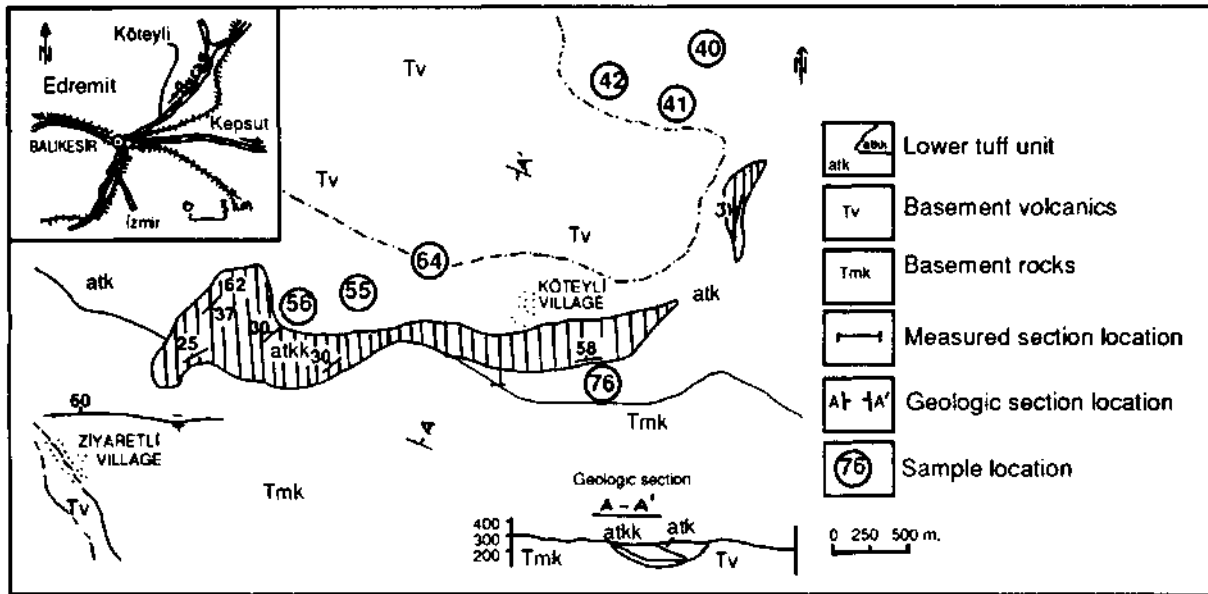

Fig. 4 - Geological map of Köteyli village surroundings.

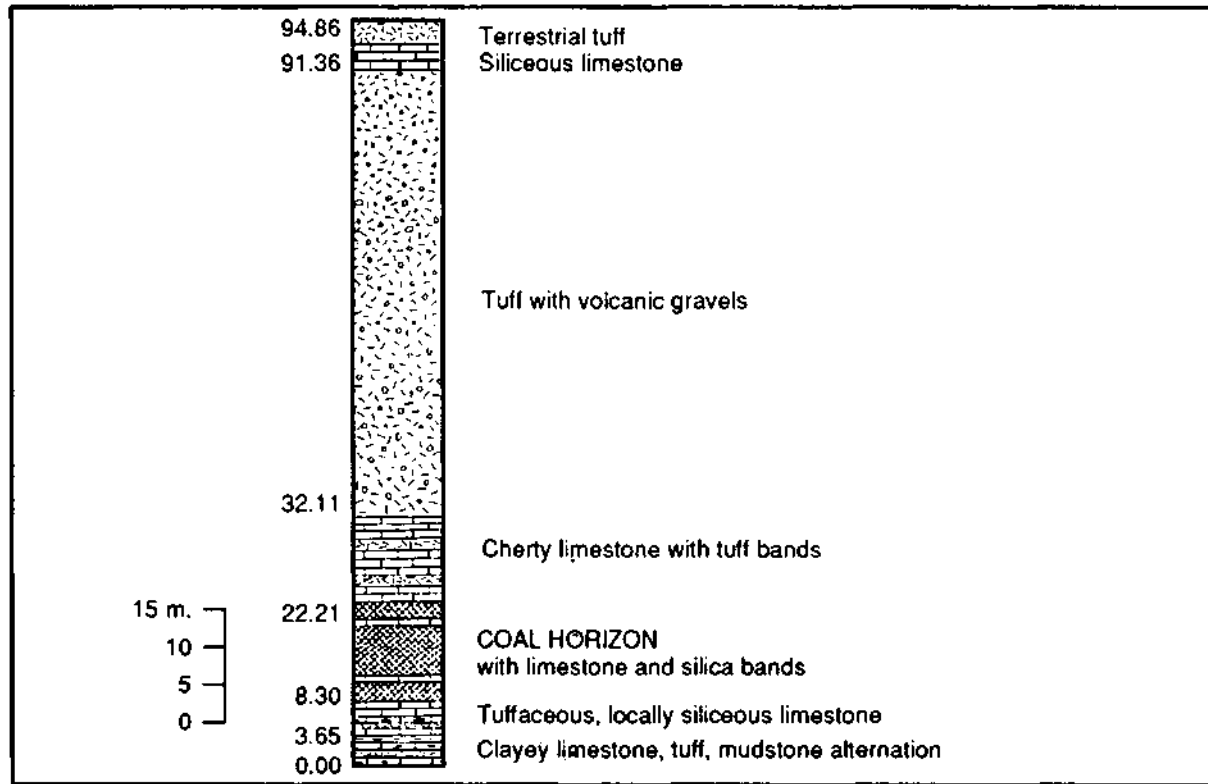

Fig. 5 - Measured type section of coaly facies of the lower tuff unit.

Lacustrine facies of the lower tuff unit overlies the basement limestone unit conformably. In places where the basement limestone unit is lacking, it overlies the basement volcanic unit sharply and unconformably. Lower borate bearing unit rests on this unit with a concordant and gradational contact.

Samples have been collected from the coal bearing horizon of the coal facies, which crops out locally within the terrestrial lower tuff. These samples have been investigated by Akgün (1985) and the following pollens were determined:

*Laevigatisporites haardti*  
*Inaperturopollenites polyformosus*  
*Triatriopollenites pseudorurensis*  
*Pityosporites microalatus*  
*Triatriopollenites rurensis*  
*Triatriopollenites bituitus*  
*Triatriopollenites coryphaeus*  
*Tripoporopollenites simpliformis*  
*Tripoporopollenites lapraferus*  
*Subtripoporopollenites simplex*  
*Polyvestibulopollenites verus*  
*Polyporopollenites stellatus*  
*Polyporopollenites undulosus*  
*Tricolporopollenites cingulum*  
*Tricolporopollenites megaexactus*  
*Tricolporopollenites densus*  
*Tricolporopollenites microhenrici*

Predominance of the pollen species with wide vertical distribution within this association, and the absence of characteristic pollen species of pre- and post-Miocene suggest that coal formations around the Köteyli village are Middle Miocene aged.

Lower tuff unit has formed by the precipitation of pyroclastic material in dust size, which were produced by volcanic eruption, on to the lake or land area.

*Lower borate bearing unit.* \_ Yellowish white colored unit shows medium to well compaction, thin to intermediate bedding and lamination. The unit carries borate beds at the bottom parts, and is composed of limestone, clayey limestone, marl, claystone, mudstone and tuff alternations.

Lower borate bearing unit is well exposed at the Tülü open pit mine (Fig. 6) and Yeniköy underground mine (Fig. 7). The unit starts with a thin bedded, occasionally laminated marl-limestone-tuff alternation. Over this alternation lies an ore zone of 0.20-76.00 m. thickness. Alternations of gray colored tuff, platy claystone-limestone and interlayers of thin bedded limestone and claystone occur together with the borates within the ore zone. The ore zone is covered by an alternation of laminat-



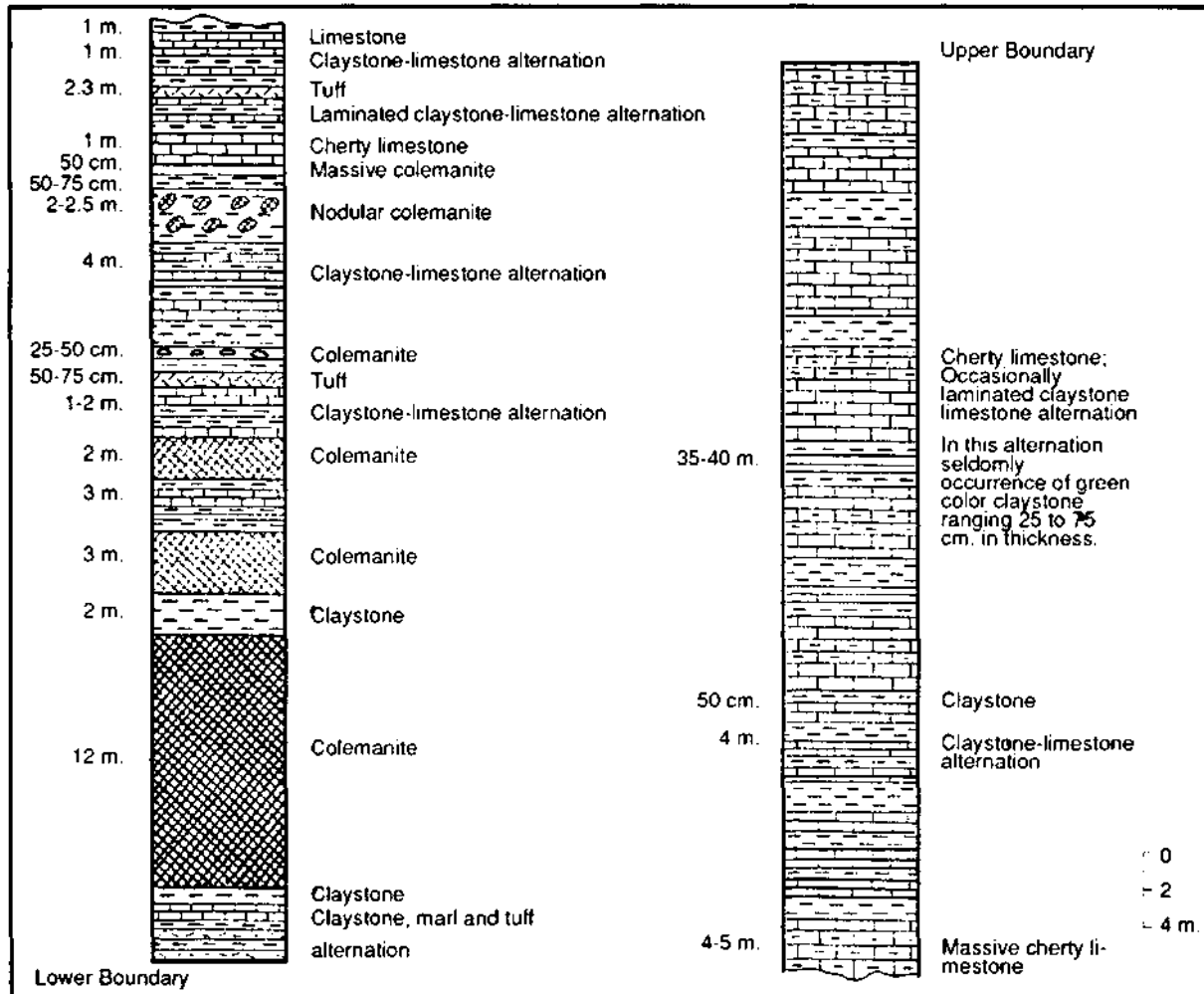

Fig. 6- Measured section of Tulu open pit.

cd, brown claystone and grayish white limestone. The unit progresses upward with an alternation of medium bedded cherty limestone, claystone and limestone. Around Yeniköy village, chert bands of 40-60 cm. thickness and porous limestone are observed at the upper parts of the unit.

Limestones within the unit are composed of sparite, biosparite, fossiliferous sparite, microsparite and micrite. Clayey limestones comprise calcite and clay minerals. They contain a little quartz. Locally they exhibit a dolomitic marl character comprising dolomite, clay, calcite and feldspar. Mudstones are generally made up of carbonaceous mud with weak compaction. They contain little amount of volcanic fragments. Tuffs occur as intercalations or interbeds within the unit.

Thickness of the ore zone at the lower parts of the unit is variable between 0.20 to 76.00 m. Boron minerals occurring at the ore zone are colemanite, ulexite, howlite, probertite and hydroboracite. Colemanite and ulexite are the minerals of economic significance. Together with borates, various amounts of non borate minerals also occur within the ore zone. Borate minerals are generally accompanied by calcite, dolomite, anhydrite and gypsum. Most common clay minerals are mononorillonite and illite (Helvacı 1983).

Lower borate bearing unit generally rests on the lower tuff unit conformably and shows gradation into the latter. Thickness of the gradation zone is variable. The unit sometimes overlies the basement volcanics unconformably, as in the case of Yeniköy village. At the top, a conformable and gradational contact exists between the lower borate bearing unit and the upper tuff unit.

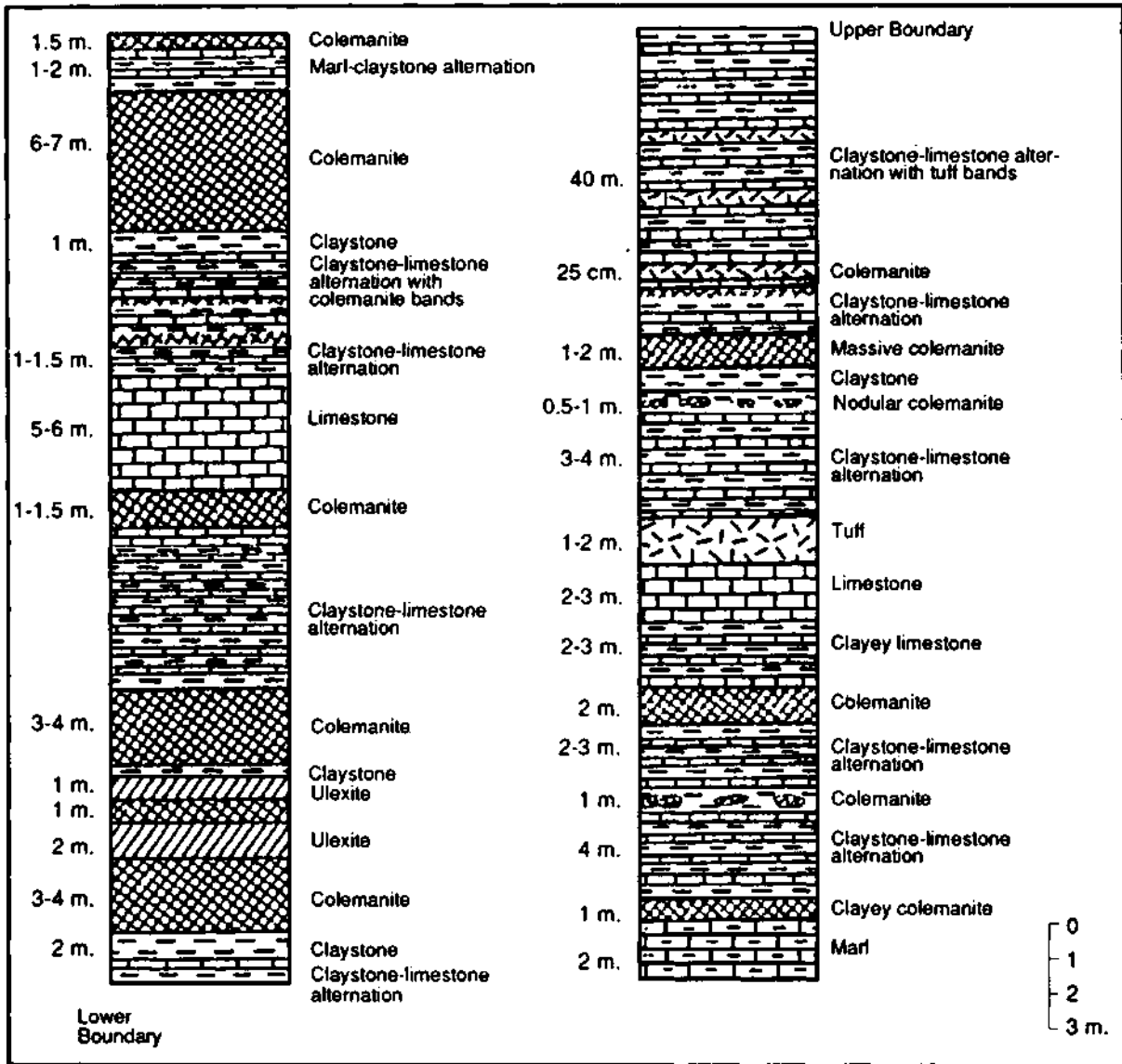

Fig. 7 - Measured section of Yeniköy deposit.

*Pityosporites lapdacus*

*Triatriopollenites biluitus*

*Triatriopollenites coryphaeus*

*Tripoporopollenites simpliformis*

*Tripoporopollenites labraferus*

*Subtripoporopollenites simplex.*

*Polyvestibulopollenites verus*

*Tricolporopollenites undulosus*

*Tricolporopollenites microhenrici*

*Tricolporopollenites pacalus*

*Tricolporopollenites cingulum*

*Tricolporopollenites megaexactus*

*Tricolporopollenites* sp. (compositae)

*Telracolporopollenites* sp.

*Periporopollenites multiporatus*

Pollen species with wide vertical distribution comprise a small percentage of this association, while no pre-Miocene species could be determined. On the other hand, various Pliocene species occur among the principal types. Thus, the unit has been ascribed to Late Miocene (Late Pannonian-Dacian).

The unit rests on the basement volcanics or basement rocks at the marginal parts. At the central part of the basin, the unit overlies the lower tuff unit regularly. Considering the extension of the unit, it may be claimed that the depositional environment was very extensive during the deposition of the unit. Depositional environments were lacustrine playa basins interconnected to each other or not. The mentioned playa basins had been rather deep during limestone deposition, but shallow during ore deposition.

*Upper tuff unit.* – This unit is extensive at the central part of the study area. Upper tuff unit arises with coarse-grained tuff at the basement. This part is characteristic with its yellowish green color. Dark green pumice fragments and porous structure are typical features. These are used as light-weight construction material in the area due to their lightness and resistance. Upper parts of the unit, on the other hand, is composed of very fine-grained, light tuff with conchoidal fracturing. Fresh surfaces are gray in color, and no mineral can be distinguished macroscopically.

Coarse-grained tuff contains two or three dimensional fracture systems, which have been stained red to brownish by the effect of circulating water, rich in iron oxide. Petrographic investigation of this tuff yielded rather high amounts of pumice, heulandite, clinoptilolite and analcime, besides lesser amounts of sanidine, quartz, plagioclase and biotite. Pumice with fibrous texture has been distributed irregularly within the rock. Some horizons of the unit are predominated by zeolite minerals such as heulandite and clinoptilolite to an extent to be considered as economic zeolite deposit. This aspect of the unit has attracted attention for various exploration programmes and evaluation projects, which may result in the starting of exploitation as a significant zeolite deposit, in near future. " .

*Lower* contact of the unit with the lower borate bearing unit is conformable and gradation exists. Upper contact with the upper borate is also conformable but no gradation exists.

The absence of carbonaceous and epiclastic intercalation within the unit, which was deposited by a new activity of volcanism that had been inactive during the sedimentation of lower borate unit, point to that volcanism continued without any interruption.

Thickness of the unit increases towards north within the basin (Fig. 8). This situation may be due to either the intensity of volcanic activity or the closeness of material to the feeding source and the depth of sedimentary environment.

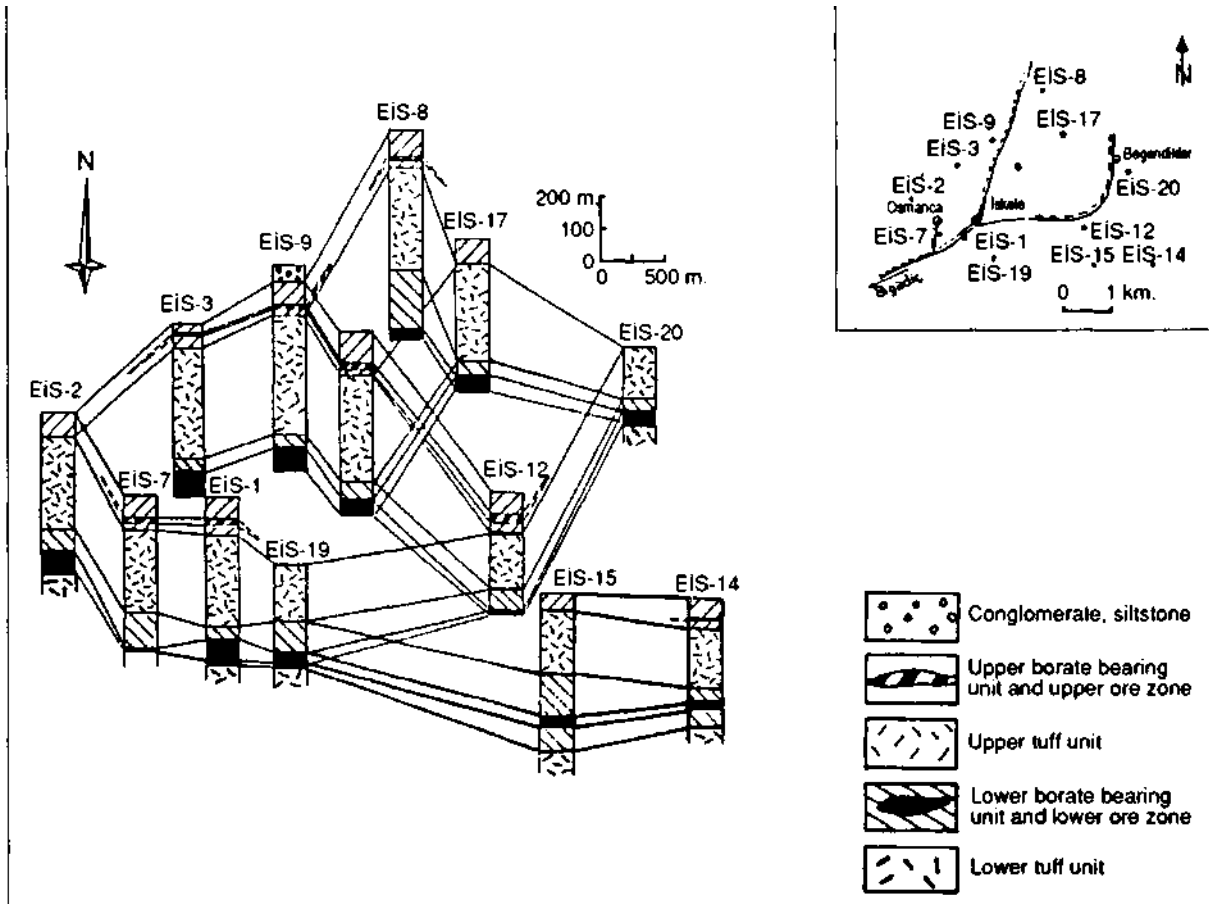

Fig. 8 - Correlation of deep drillings completed in Bigadiç basin.

*Upper borate bearing unit.* \_ The unit comprises an alternation of limestone, claystone, clayey limestone, marl and tuff, and carries borate beds at intermediate levels.

The unit starts with an alternation of thin-bedded, tuff banded claystone, limestone and marl at the bottom. Over this alternation, a soapy platy claystone and ore zones rest. Ore zone is overlain by reddish-brown laminated claystone. An alternation of claystone and limestone, with thin to medium tuff and limestone bands covers the former lithologies. The unit ends up with a thick bedded limestone, occasionally containing chert bands (Fig. 9).

Color of the limestone in this unit is whitish to creamy. It is partly siliceous and contains dissolution cavities. Thickness of beds vary between 0.2 to 40 cm. Thin bedded marl is yellowish to creamy colored. Color of the tuffs is yellowish green due to alteration. They are medium bedded. They contain macroscopic biotite and feldspar. They locally reach thickness of 3 to 5 m. Clays are reddish-brown, green and gray in color, and have a soapy appearance. Platy claystones form guide levels at the top and bottom of the ore zone.

Ore zone occurs at the middle parts of the upper borate bearing unit. Thickness of the ore zone changes between 0.10 to 80.00 m. Economically exploited boron minerals are colemanite and ulexite. Ulexite is dominant at the Acep, Kireçlik,

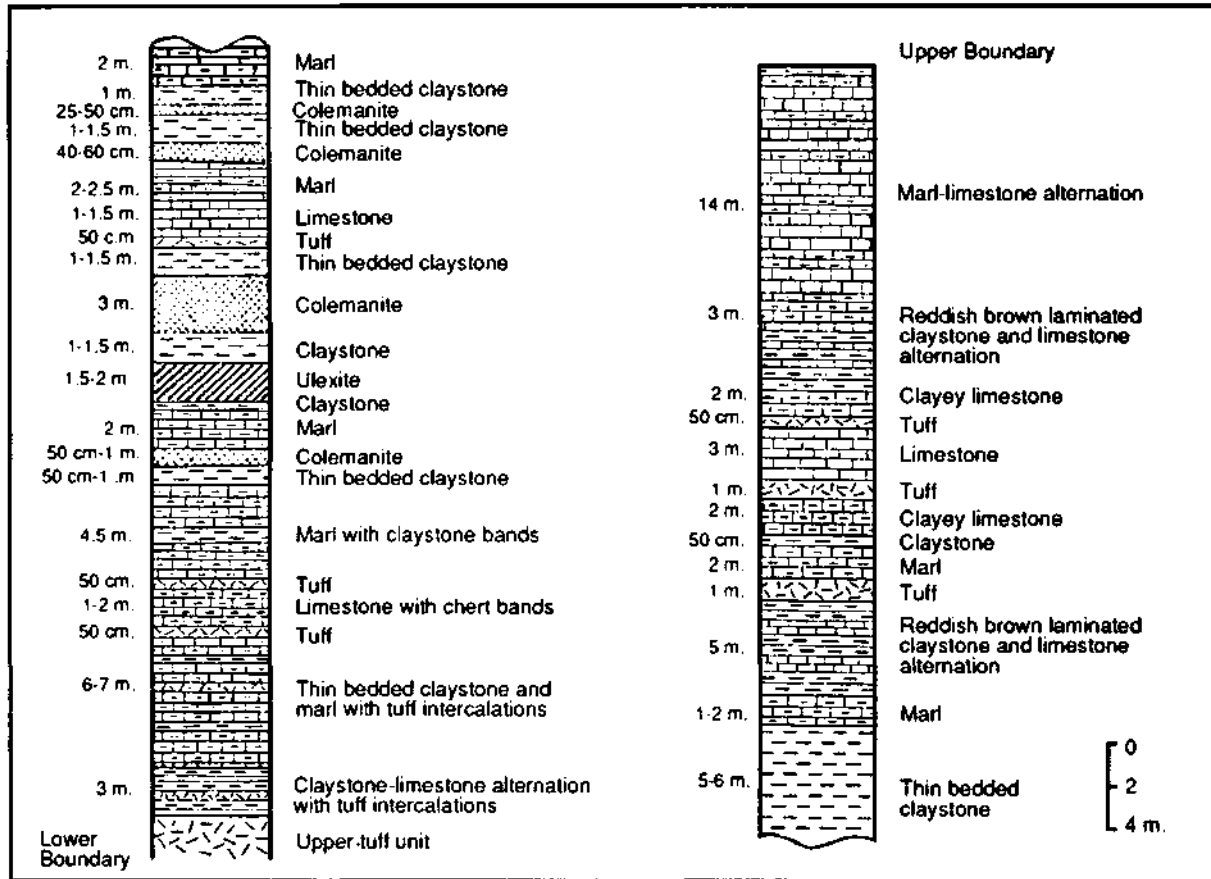

Fig. 9 - Generalized section of upper borate bearing unit in Kireçlik region.

Arka and Öngünevi deposits, while colemanite predominates in Avşar and Simav deposits. Other boron minerals determined at the ore zone of upper borate bearing unit are, meyerhofferite, pandermite, probertite, howlite, tunellite, hydroboracite and inyoite. Thickness, number and distribution of borate beds at the productive pits are rather variable. In general, the borate beds have a lenticular structure.

Upper borate bearing unit overlies the upper tuff unit sharply and conformably at the bottom. At the top of the unit, recent sediments overlie unconformably.

The following ostracoda species were determined in the samples from various levels of the upper borate bearing unit (Gündoğdu, 1982):

*Bakunella dorsoarcute* (Zalanyi)

*Candona convexa* Livental

*Candona paralella pannonica* (Zalanyi)

*Amplocypris* cf. *recta* (Resus)

*Hungarocypris hierophlyphica* (Mehes)

This association indicates Upper Pannonian for the lower and middle parts of the unit, and *Lower Pontian* for the upper part of it.

The unit is a product of clastic and chemical sedimentation that started again following the volcanic activity, which produced the upper tuff unit. Laminated alternation of carbonaceous rocks and clastic rocks reflects the seasonal climatic changes during the precipitation of the unit and as well as facies changes and water level fluctuation in the basin. Tuff bands

within the unit, on the other hand, indicate that the volcanic activity also continued during sedimentation, though in short intervals. As the unit is observed in a rather limited area, it can be concluded that the depositional environment became very small during the deposition of the upper borate bearing unit.

*Basalt.* - This black and grayish black colored unit has cut all the other units older than itself. Thickness is not so big.

By the petrographic examination of the samples collected from the unit, a matrix of ophitic texture due to the irregular distribution of feldspar microlyths was determined, together with augite and olivine crystals that present between the feldspar crystals.

#### QUATERNARY

##### Recent sediments

These rocks crop out around the İskele and Osmanca villages, and between the Avşar and Simav pits, at the central part of the investigated area.

The unit starts with a basal conglomerate with limestone pebbles. The conglomerate is overlain by claystone, sandstone and pebblestone banded siltstone. Siltstone is gray and locally yellowish red in color, and thin bedded. Claystone is yellowish red and laminated. The cement of pebblestone components is tuff, which is partly altered into clay. Thickness of the unit ranges among 3 to 180 m.

The unit overlies upper borate bearing unit unconformably. At the top, it underlies alluvium, again unconformably. The unit carries pre Neogene and Neogene aged materials. By regional correlation, it has been ascribed to Quaternary in age. Alluvium, which covers all the units unconformably, is composed of the pebbles, sand and clays of basement rocks and Neogene units.

#### TECTONISM

Neogene sediments of the Bigadiç volcano-sedimentary basin have deposited in a number of individual or interconnected basins, bordered by extensive basement rocks. The formation of these basins may go back as far as the beginning of Neogene. General trend of the sediments is NE-SW. Main tectonic elements of the investigated area are folds, faults and unconformities.

Units composing the stratigraphic sequence at the area have general dips of 0°-35°, except for some local variations. The beds generally dip to NW and SE.

##### Folds

Synsedimentary and post-depositional folds can be distinguished at the Bigadiç volcano-sedimentary basin. Synsedimentary folds are common among the claystone and claystone-limestone alternations. The horizons at the top and bottom of these folds do not show any inflection or dip changes.

Post-depositional folds have a general axial trend in NE-SW. These folds, contrary to the synsedimentary ones, have affected the ore zone. Ore-bearing horizons are thicker at the apices of synclines but thinner at the flanks of folds.

Small-scale folds are abundant in the upper borate bearing unit. These small-scale folds appear as overturned anticline and synclines, isoclinal folds and flexures. The lower borate bearing unit, however, does not bear so frequent small scale folds. The reason is that, the unit is overlain by the upper tuff and upper borate bearing unit, which protected the unit against deformation.

##### Faults

In the Palaeozoic and Mesozoic rocks, comprising the basement at the area, various rise and falls occurred due to the block faulting of pre-Miocene growth faults and dislocations. This resulted in the formation of sedimentary basins, where the Neogene sediments were deposited. Large scale faults, which gave rise to the generation of the sedimentary basins, have also served to conduct the boron exhalations to the environment during the deposition of the lower and upper borate bearing units.

Contemporaneous faults with the deposition of units (growth faults) caused the thickening of ore-zones. Examples of these faults are the Kisekaya fault and the one observed in the south of Beğendikler village.

Recent faults in the basin have affected the ore zones. Ore veins have altered within the fault zones.

**BİGADIÇ BORATE DEPOSITS**

Bigadiç borate deposits occur in two zones, as the lower and upper borate zones, separated from each other by the upper tuff unit. Distribution of the thickness of upper borate zone, occurring in the middle part of upper borate bearing unit, according to borehole data is as follows:

| <i>District</i> | <i>Ore zone thickness (m.)</i> |
|-----------------|--------------------------------|
| Avşar-Simav     | 2-80.00                        |
| Günevi          | 0.5-23.60                      |
| Kireçlik        | 0.7-39.00                      |
| Yellicetepe     | 3.3-18.60                      |
| Around İskele   | 0.2-73.70                      |

Aerial distribution of thickness of lower borate zone, occurring in the lower portion of the lower borate bearing unit, according to borehole data is given below:

| <i>District</i> | <i>Ore zone thickness (m.)</i> |
|-----------------|--------------------------------|
| Yeniköy         | 0.2-76.00                      |
| Tülüovası       | 8.2-54.00                      |
| Deep boreholes  | 8.2-67.90                      |

According to these data, thickness of the upper borate zone varies between 0.10-80.00 m. and that of lower borate zone between 0.20-76.00 m. Although the thickness of the upper borate zone appears to be bigger than the lower borate zone, net ore thickness of lower borate zone is bigger than that of the upper (Figs. 10 and 11).

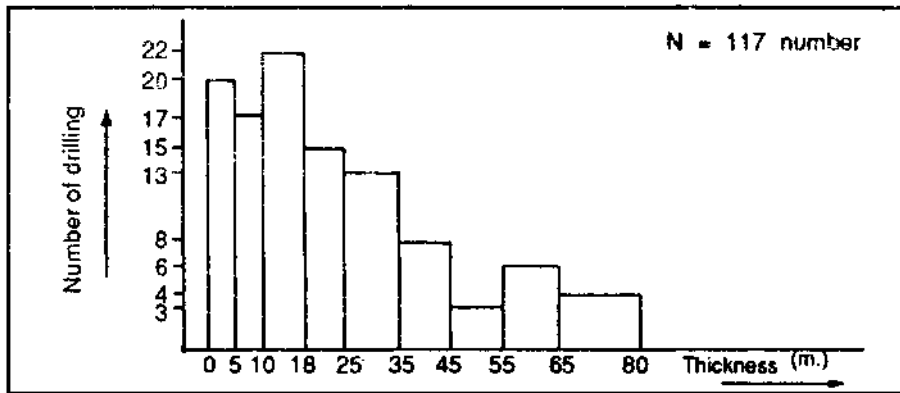

Fig. 10 - Geometric frequency distribution of ore zone thickness according to the drillings completed in upper borate bearing unit.

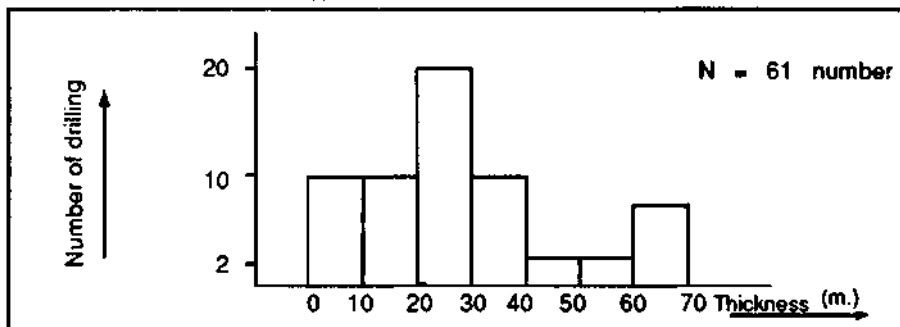

Fig. 11 - Geometric frequency distribution of ore zone thickness according to the drilling completed in lower borate bearing unit.

Correlation of the ore veins cut by drilling at the lower borate zone is easier than that of the upper zone. The reason is that, the extension of ore veins in the lower borate zone is more regular. In addition, alteration is not as effective in the lower borate veins as the upper zone, because the upper tuff and upper borate bearing units have preserved it. Tuff bands within the ore zone of lower borate bearing unit are more abundant than the upper borate zone.

Correlation of the deep boreholes performed at the basin is given in Figure 8. As seen from the figure, thickness of the lower borate ore zone is more homogenous than the upper borate ore zone.

Etibank's mineral production in the area comes from open pit and underground mines. Distribution of mines in the area is as follows: Yeniköy underground and Tülü open pit mines at the lower borate zone, and On and Arkagünevi, Kireçlik, Avşar, Simav underground and Acep open pit mines at the upper borate zone.

Other than the currently producing mines, there are closed mines in the basin. These are; Mezarbaşı, Acep, Salmanlı, Beğendikler and Çamköy underground and Kurtpınarı open pit mines in the upper borate zone. Detailed stratigraphy of these pits are presented here under.

#### Avşar and Simav deposits

Avşar and Simav underground mines are located at the southwestern margin of the basin within the upper borate bearing unit. Colemanite is more dominant than ulexite in these deposits. Nevertheless, both minerals are produced together.

6 ore veins exist at the Avşar mine. 4 of these veins comprise colemanite and the remaining 2, ulexite. The order of veins from bottom to top is as follows: Colemanite (30 %  $B_2O_3$ ), ulexite (32 %  $B_2O_3$ ), ulexite (33 %  $B_2O_3$ ), colemanite (34 %  $B_2O_3$ ), colemanite (42 %  $B_2O_3$ ), colemanite (35 %  $B_2O_3$ ). Claystone-limestone-marl alternations of variable thickness occur between the veins.

At the Simav mine, the sequence in the ascending order is as follows: 2-2.5 m. colemanite, claystone-limestone alternation, 4 m. ulexite (34 %  $B_2O_3$ ), tuff and limestone bands, 2.5-3 m. colemanite (35 %  $B_2O_3$ ), claystone-limestone alternation, 2.5 m. colemanite (36 %  $B_2O_3$ ), claystone and tuff bands and 2.5 m. thick colemanite ore (29 %  $B_2O_3$ ) (Fig. 12).

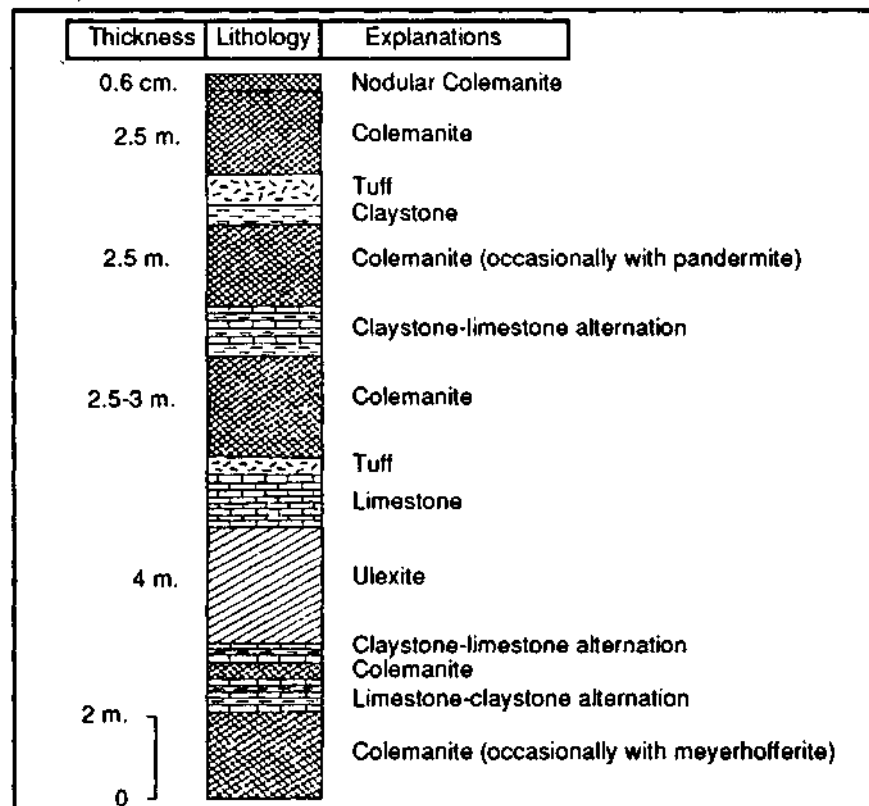

Fig. 12 - Detail measured section of Simav deposit.



In Figure 13, ore zone profile and % B<sub>2</sub>O<sub>3</sub> grades of ore veins are given for the AS-4 borehole at the Avşar-Simav area.

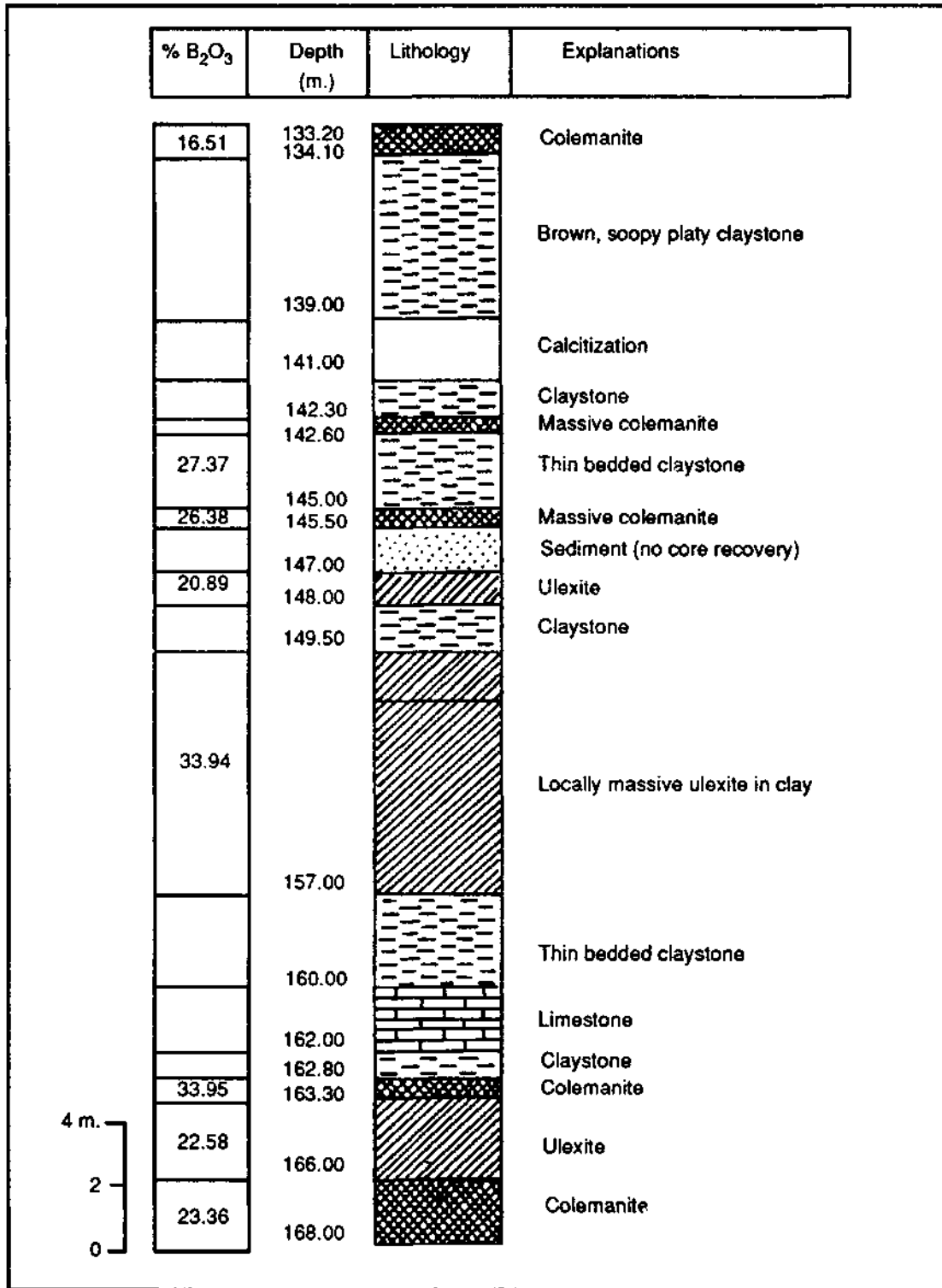

Fig. 13 - Ore zone distribution and % B<sub>2</sub>O<sub>3</sub> contents of ore beds of AS-4 drill core completed between Avşar and Simav deposits.

### Kireçlikdeposit

This deposit is located at the southeastern part of the basin, in the south of Kireçlik hill, within the upper borale bearing unit. Colemanite and ulexite are exploited from the mine.

Ore zone arises with white colored, pure and massive colemanite at the bottom, whose thickness is about 0.5-1 m. Proceeding upward, an ulexite vein of thickness 3 to 4 m. lies on the colemanite. Upper part of this ulexite vein carries secondary ulexite veins of 5-10 cm. thick. Over the ulexite lies a laminated claystone-limestone-tuff and marl alternation, 4-5 m. thick, in which limestone is dominant. Another ulexite vein of thickness 3-4 m. lies over this alternation and it carries 5-10 cm. thick bands of meyerhofferite. A 2.5 m. thick claystone-limestone alternation covers the ulexite. At the uppermost part of the ore zone, 2.5-3 m. thick colemanite has deposited (Fig. 14). Produced ore grade of ulexite is 30.50 %  $B_2O_3$  and colemanite 34 %  $B_2O_3$  at the Kireçlik mine.

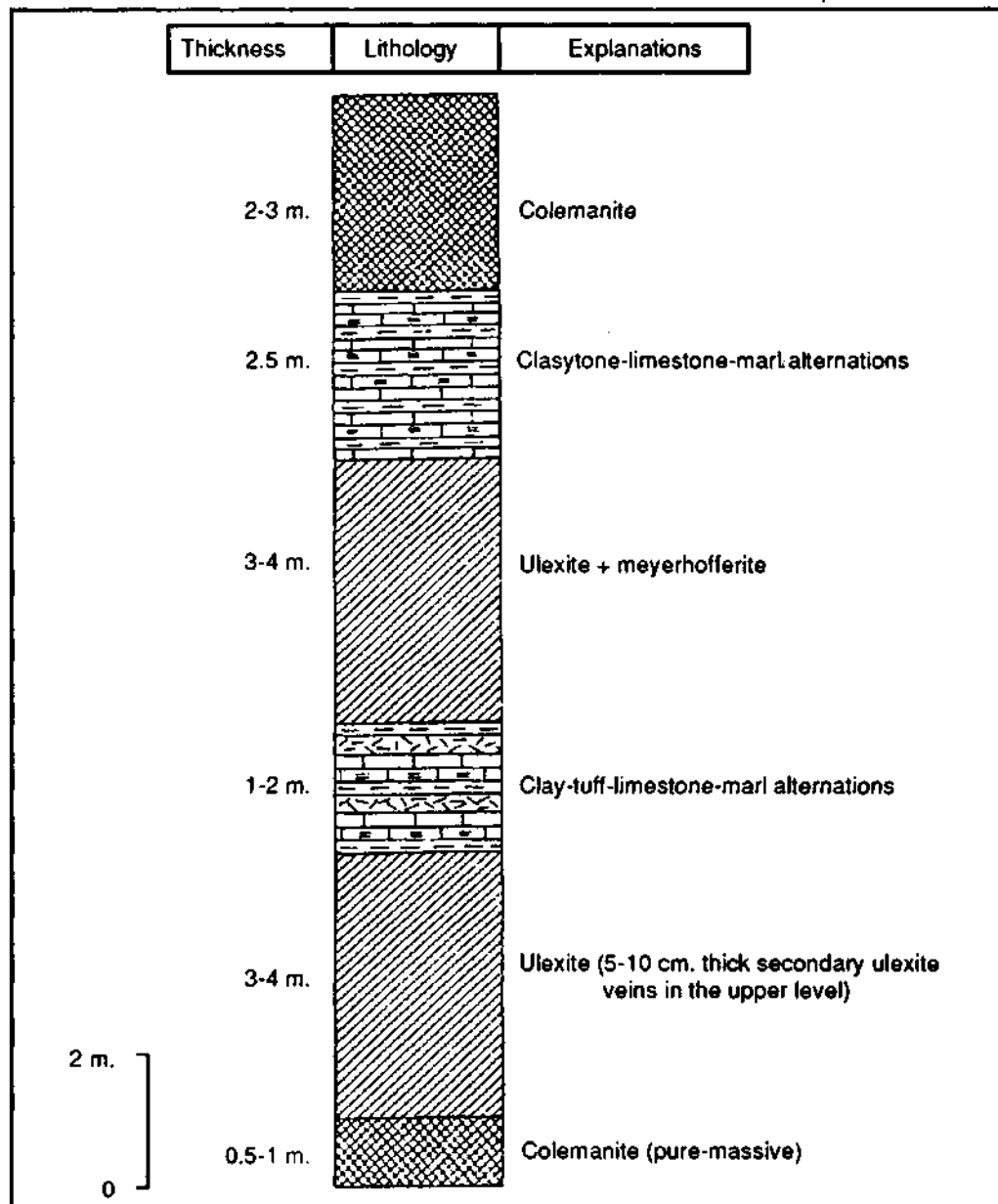

Fig. 14 - Measured section of Kireçlik deposit.

In Figure 15, ore zone profile and % B<sub>2</sub>O<sub>3</sub> grades of ore veins are given for the KS-17 borehole, drilled in the north of the mine.

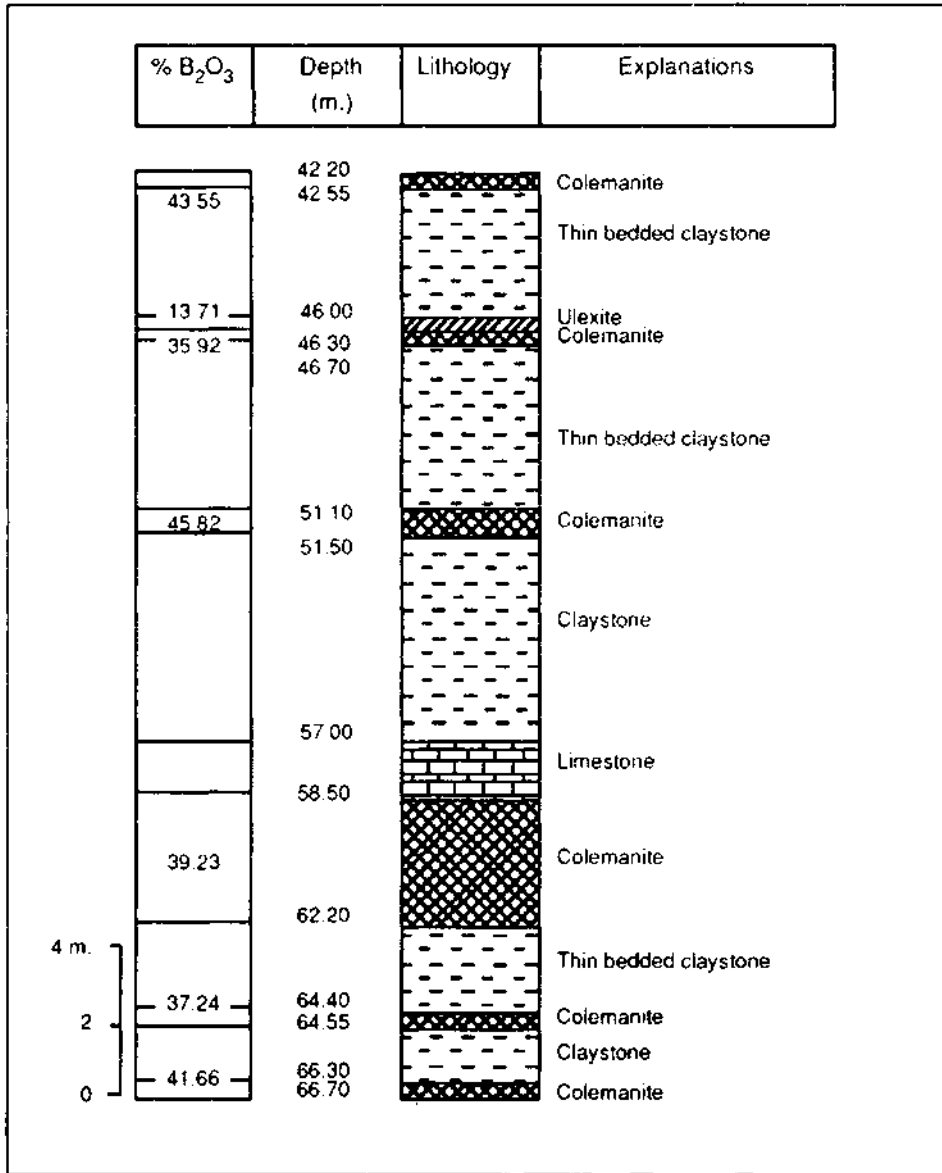

Fig. 15 - Ore zone distribution and % B<sub>2</sub>O<sub>3</sub> contents of ore beds of KS-17 drill core completed in Kireçlik area.

**Günevi deposits**

Günevi deposit are located in the northeastern part of the basin, within the upper borate bearing unit. Ulexite is more dominant than colemanite.

Ore zone of the Öngünevi deposit starts with 10-15 cm. thick colemanite at the basement. Clays, intercalated within the colemanite occasionally contain hydroboracite. An ulexite zone of 5 to 6 m. thick, with camel's-tooth appearance lies over the colemanite. These camel's-tooth like ulexite crystals may be as big as 5 cm. Clay has filled the space between the crystals. Tunellite mineral, which looks like muscovite flakes with its glimmering crystals, occur within the ulexite. Diameter of the crystals is about 2 cm, 10-15 cm. thick hydroboracite horizon occurs over the ulexite. Another ulexite of 1-1.5 m. thick

with clay bands overlies hydroboracite. Thickness of clay bands is about 10-15 cm. The uppermost level comprise gypsiferous colemanite with thickness 1-1.5 m. (Fig. 16).

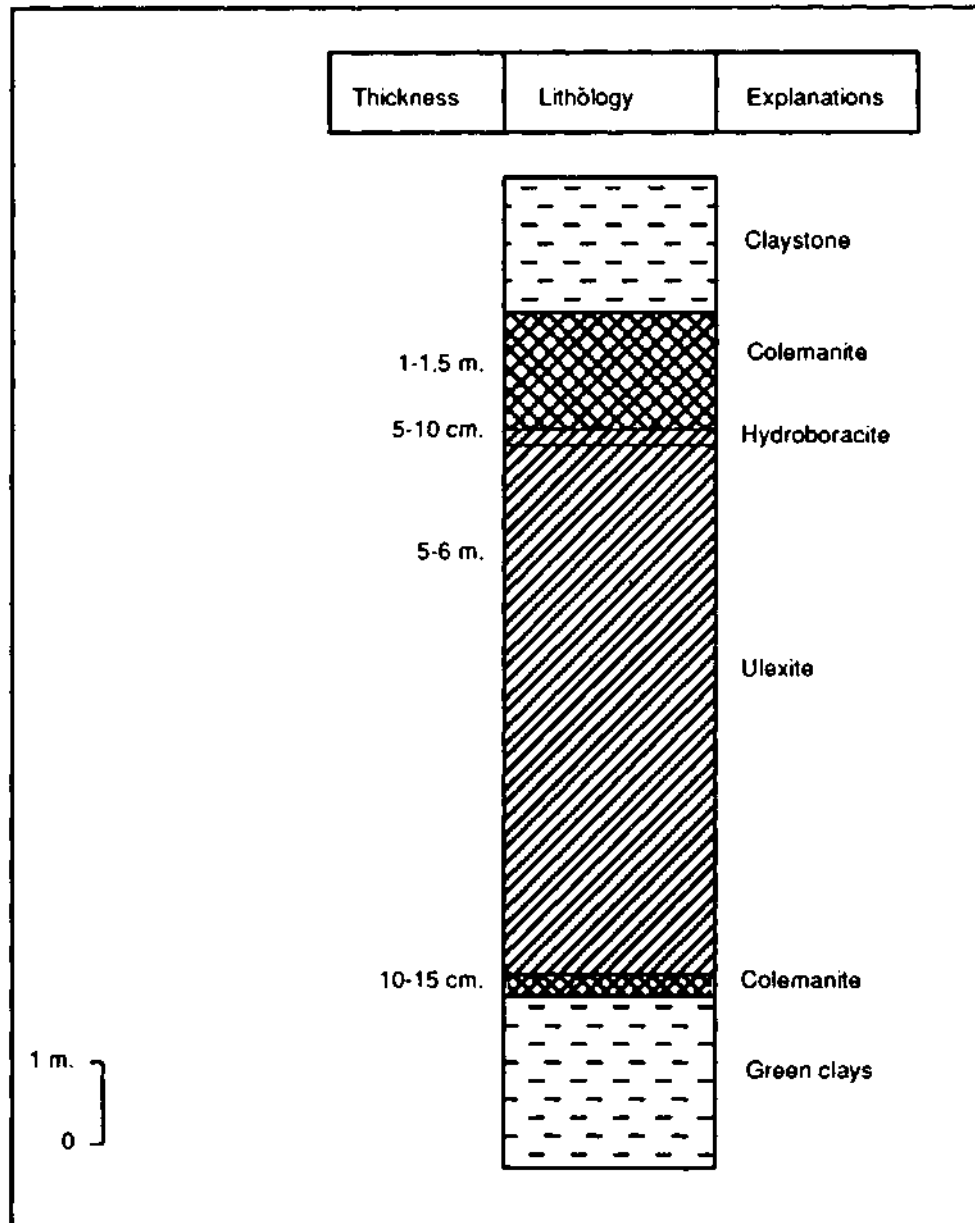

Fig. 16 - Measured section of Öngünevi deposit.

The ore zone of Arkagünevi deposit arises with colemanite at the basement. It proceeds with an ulxile vein of 4-6 m. thickness, which contains a 20-25 cm. thick clay band. Ulexite is overlain by a clayey horizon and between these two, tunnelitic and colemanite layers have been determined. Thickness of these are 5-10 cm. Clayey bed contains marl bands. Another ulexite in camel's-tooth type, whose thickness varies from 3 to 3.5 m., overlies the clayey bed. 1.5-2 m. thick another clay zone covers the ulexite, followed by a colemanite zone, in which fibrous colemanite is intercalated with clays. Thickness is 5-10 cm. At the upper levels of colemanite zone, colemanite crystals are observed within nodular, soapy clays. Fractures, de-

veloped during the late-diagenesis stage have been filled by secondary white, glimmering and pure colemanite (Fig. 17). Ore grade of the ulexite produced from Arkagünevi deposit is 31 % B<sub>2</sub>O<sub>3</sub>.

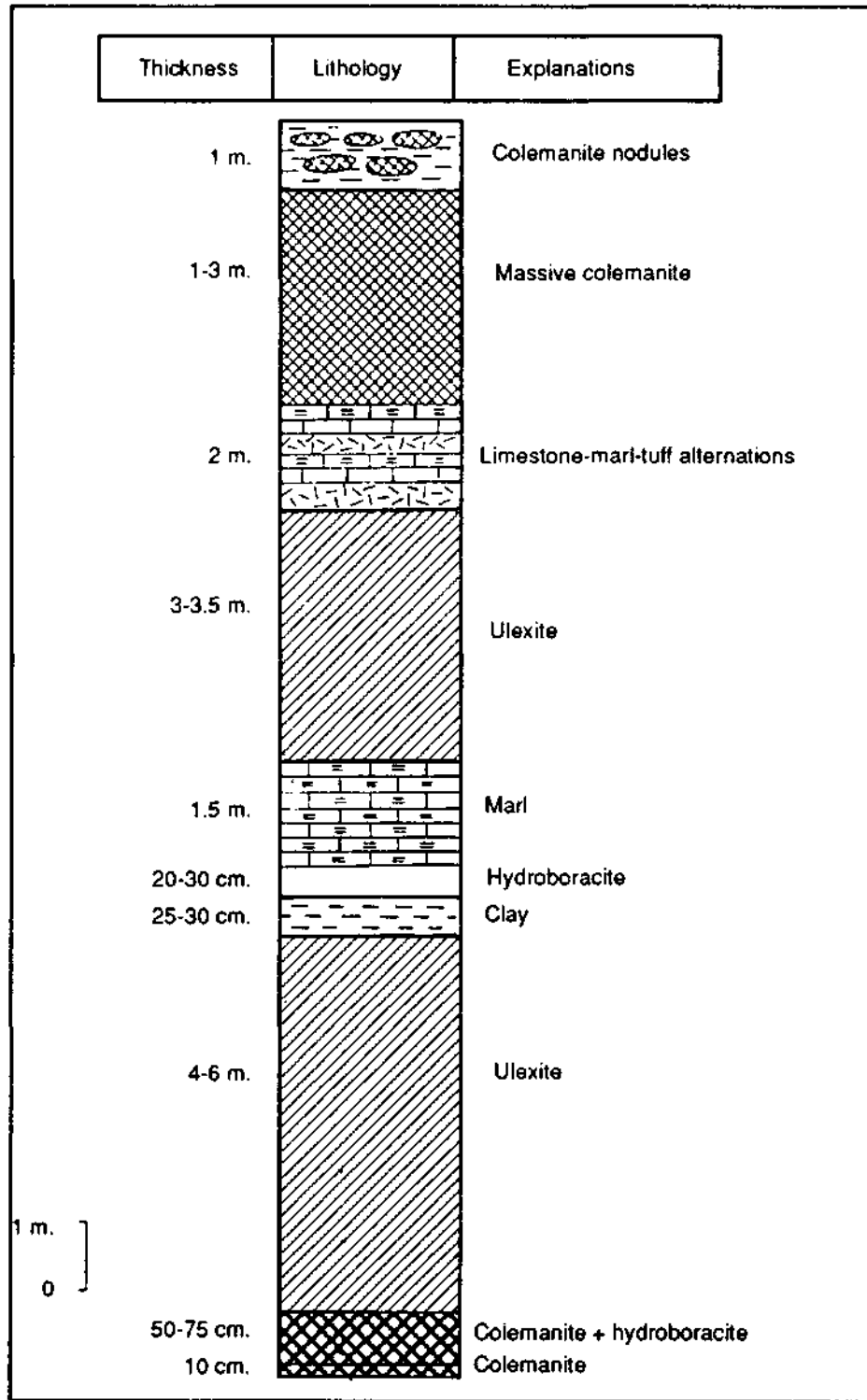

Fig. 17 - Measured section of Arkagünevi deposit.

In Figure 18. ore zone profile and %  $B_2O_3$  contents of ore veins are given for the GS-3 borehole at the Günevi mining area.

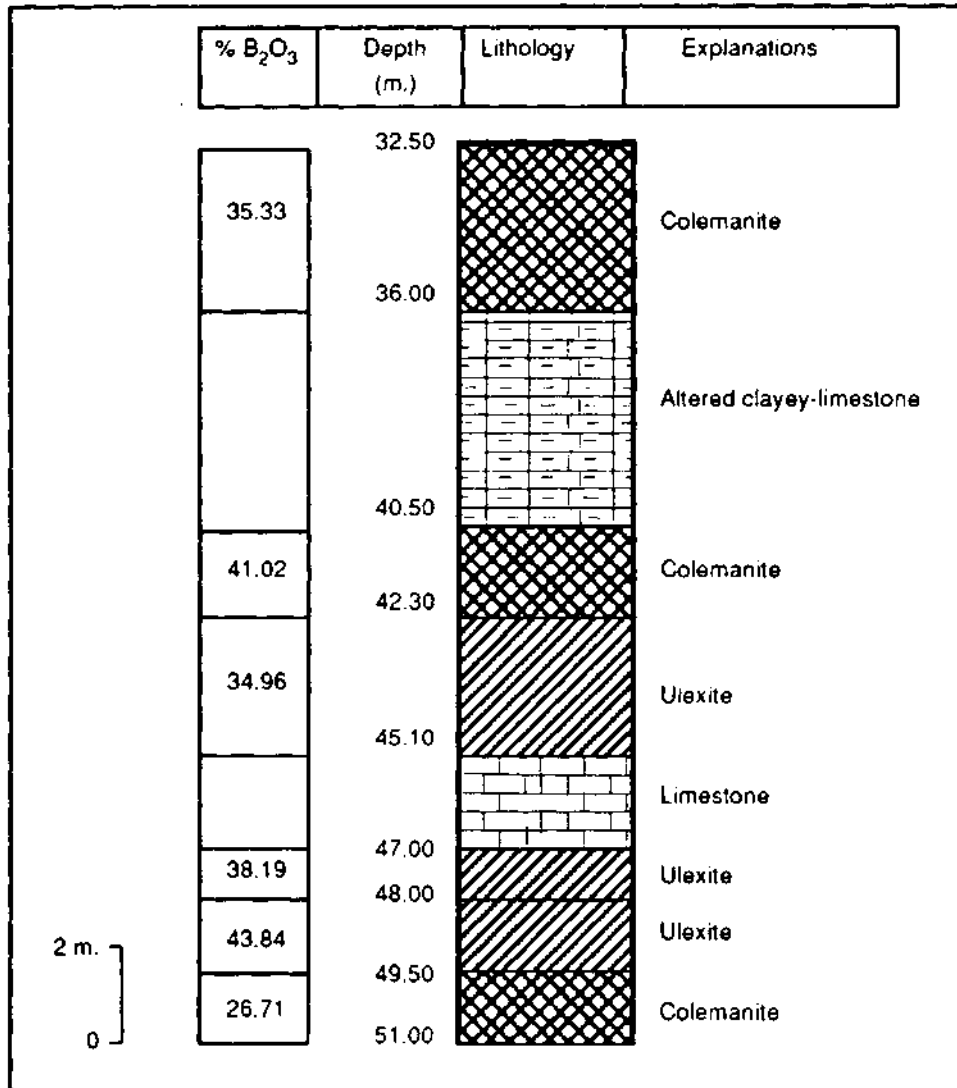

Fig. 18 - Ore zone distribution and %  $B_2O_3$  contents of ore beds of GS-3 drill core completed in Günevi area.

#### Acep deposit

This mine is located almost in the central part of the basin within the upper borate bearing unit. Both colemanite and ulexite are produced from the deposit, but ulexite is more dominant. The sequence from the bottom in the ascending order is as follows: 0.5-1 m. thick colemanite (33 %  $B_2O_3$ ) horizon, 25-50 cm. clay horizon. 1.5-5 m. thick ulexite (30 %  $B_2O_3$ ) (this horizon contains two separate colemanite layers whose thickness may reach 20 cm. locally), 25 cm. colemanite, 1-2 m. thick marl and clay horizon, 50 cm. thick ulexite (Fig. 19). Proceeding upward, clay and marl alternations increase in number and non economic colemanite bands occur. At the uppermost part, an alternation of claystone and limestone is observed. There are sporadic occurrences of inyoite, meyerhofferite and gypsum within the bed. Ore zones dip north, towards the İskele village.

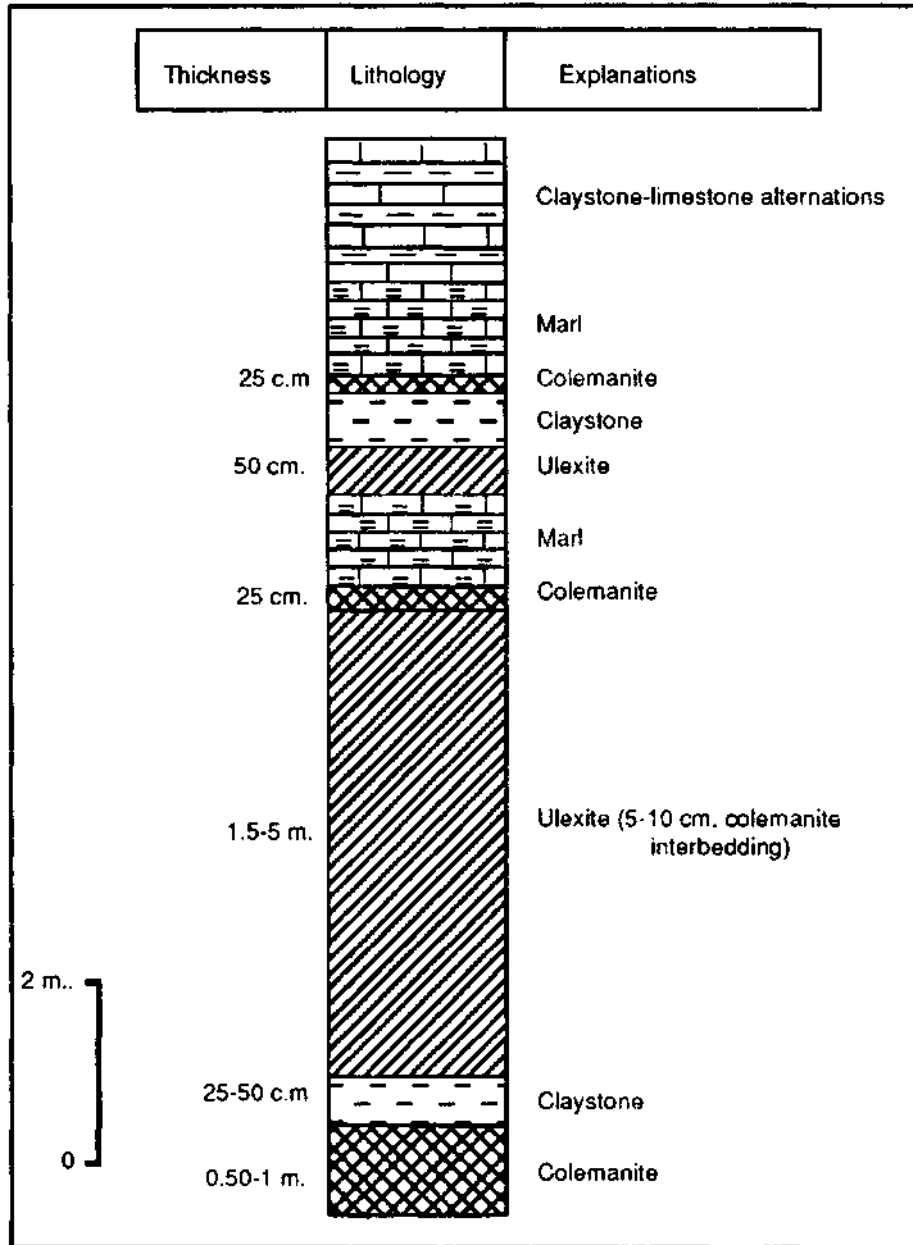

Fig. 19 - Measured section of Acep deposit.

In Figure 20, ore zone profile and %  $B_2O_3$  contents of ore veins are given for the APZ-22 borehole.

#### Tülü deposit

Tülü deposit is located in the lower borate bearing unit. Colemanite is produced from the deposit.

The sequence observed within the deposit from bottom to top is as follows: 10-12 m. thick colemanite (33 %  $B_2O_3$ ), 2 m. clay, 2-3 m. thick colemanite (as small nodules), 2.5-3 m. thin laminated clay-limestone alternation, 2 m. colemanite, 4-5 m. claystone-limestone alternation, 25-30 cm. colemanite, 7-8 m. claystone-limestone alternation, 2.5-3 m. nodular colemanite, 50-75 cm. clay, 15-50 cm. massive colemanite (Fig. 16).

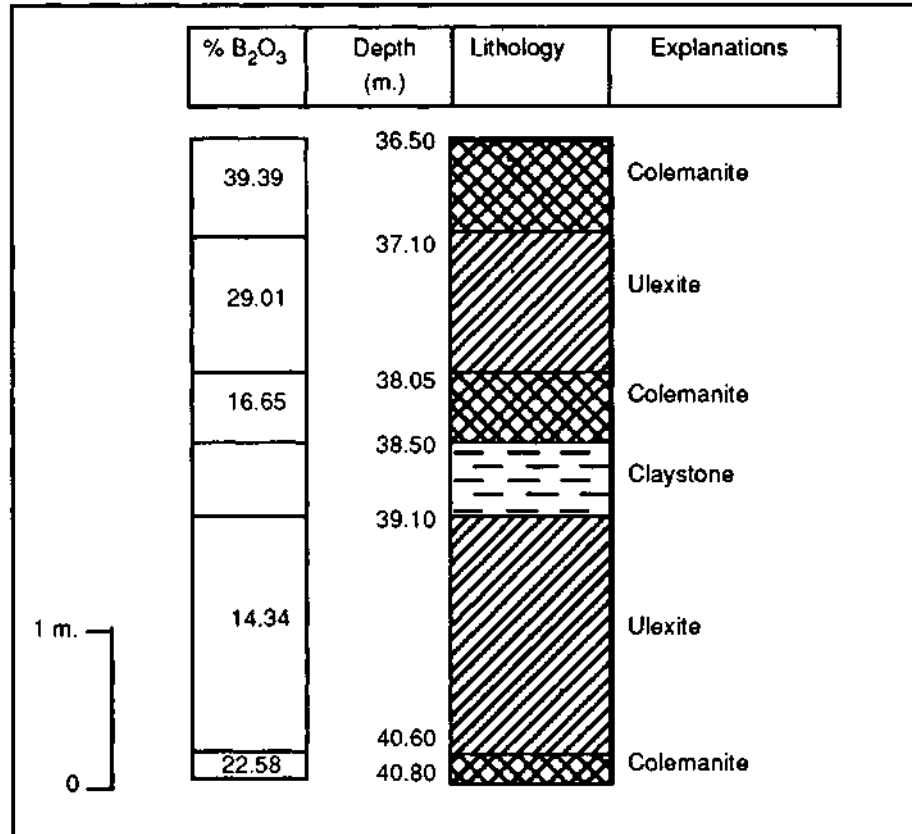

Fig. 20 - Ore zone distribution and % B<sub>2</sub>O<sub>3</sub> contents of ore beds of APZ-22 drill core completed in Acep area.

In Figure 21, ore zone profile and % B<sub>2</sub>O<sub>3</sub> contents of ore veins are given for the TS-5 borehole at Tülü plain.

Yeniköy deposit

This mine is located at the northwestern part of the basin, in the lower borate bearing unit. Ulexite deposition is more dominant than colemanite in this deposit.

The sequence from bottom to top is as follows: 3-4 m. colemanite, 2 m. ulexite, 1 m. colemanite, 1 m. ulexite, 20-30 cm. clay, 3-4 m. colemanite with clay bands, 12-14 m. claystone-limestone alternation with 10-15 cm. colemanite, 1-1.5 m. colemanite, 5-6 m. limestone, 20 m. claystone-limestone alternation with colemanite bands, 1 m. green clay, 6-7 m. colemanite, 1-2 m. marl, 1.5 m. colemanite, 9-10 m. claystone-limestone alternation (contains a colemanite band of 1 m. thickness), 2 m. colemanite, 0.5-1 m. clay, 25 cm. colemanite (Fig. 7).

The mines, whose stratigraphic sequences have been explained above, are the currently producing mines. There are also closed mines in the area, which are Mezarbaşı, Acep, Salmanlı, Beğendikler, Çamköy underground mines and Kurtpınarı open pit, located in the upper borate zone.

Although detailed stratigraphy of the closed mines cannot be given here, boron minerals characteristic for each deposit, determined from the tailing dumps, may be slated as follows: colemanite (and pandermite) for Mezarbaşı deposit; colemanite and ulexite for Acep deposit; colemanite for Salmanlı deposit; colemanite and ulexite for Beğendikler deposit; colemanite and ulexite for Çamköy deposit (tailings also contain meyerhofferite). Colemanite and ulexite had been produced from the Kurtpınarı open pit, where howlite nodules are found within the clays alternating with colemanite.



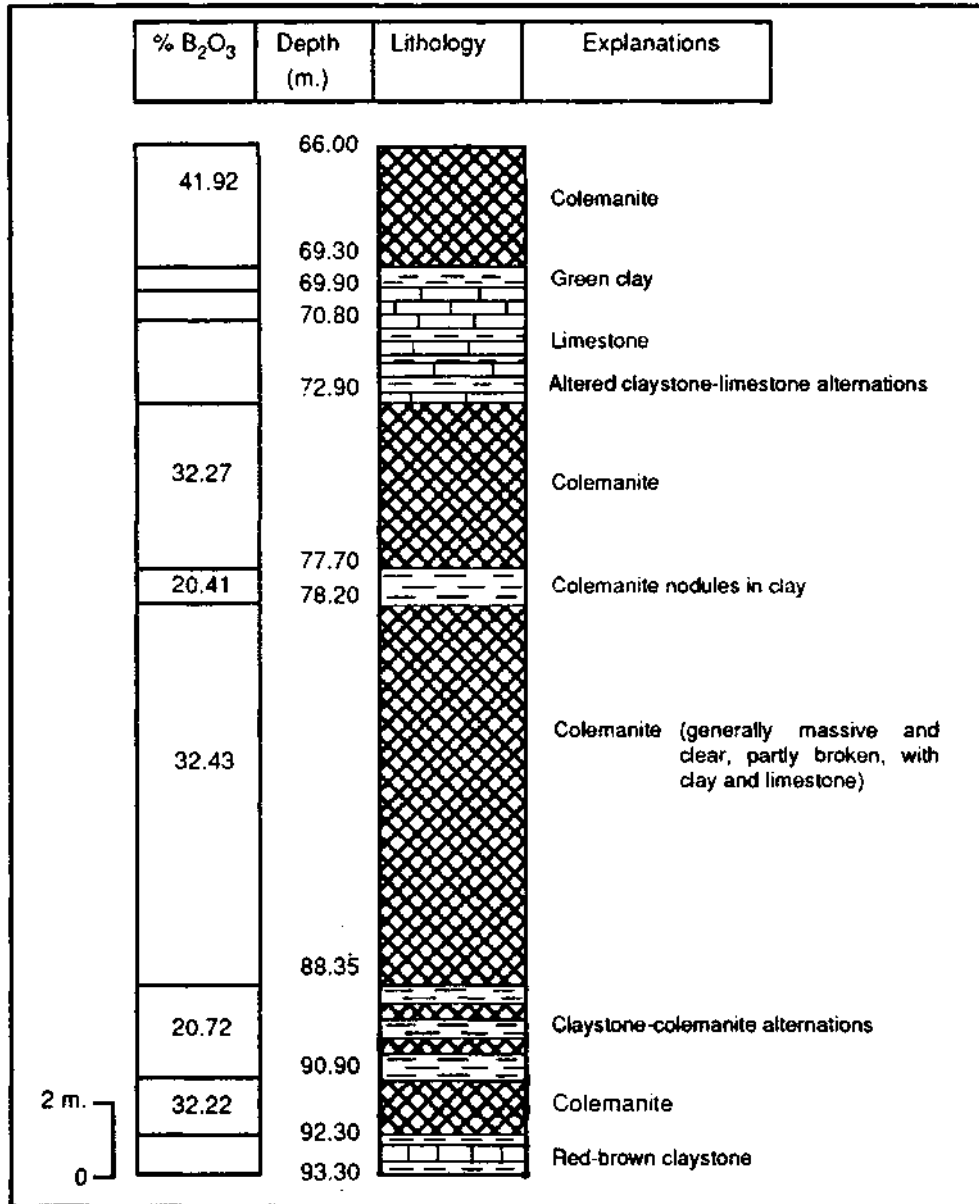

Fig. 21- Ore zone distribution and % B<sub>2</sub>O<sub>3</sub> contents of ore beds of TS-5 drill core completed in Tülü plain.

**MINERALOGY**

As the borate precipitation follows that of calcium carbonate, and due to the Ca<sup>++</sup> abundance, the first borates to precipitate should be Ca-borates. As the sedimentation and evaporation progress, Ca-Na-borates start to precipitate. If the suitable circumstances exist and if the Na-concentration has reached the satisfactory level, Na-borate precipitation follows. Further precipitation sequences include the re-precipitation of Ca-Na-borates and Ca-borates, respectively. This zonation represents a complete mineralogic evolution in a borate deposit (Helvacı, 1983).

As the Na-borates have not precipitated at the Bigadiç borate deposit, it exhibits an incomplete sequence of mineral distribution. Moreover, Bigadiç borate deposit may roughly be considered as a Ca-borate deposit.

In both of the individual borate zones at the Bigadiç basin, colemanite and ulexite are dominant over other boron minerals. Other boron minerals, determined within the basin are; howlite, probertite and hydroboracite in the lower borate

zone; inyoite, meyerhofferite, pandermite, probertite, hydroboracite, howlite and tunclite in the upper borate zone (Helvacı and Alaca, 1984).

Table 1 gives the list of boron minerals determined at the deposits in Bigadiç basin, and Table 2 shows the chemical analysis results of minerals produced.

Clays, accompanied with boron minerals, generally belong to the smectite group. Zeolite minerals, such as heulandite and clinopulolite have been determined in the tuff horizons. Calcite, aragonite, dolomite, gypsum, quartz and opal-CT are distributed all over the deposits (Helvacı and Dora, 1985).

### **Boron minerals of economic significance**

Economic borate exploitation covers the colemanite and ulexite minerals in all deposits of the area.

Colemanite occurs as nodular, platy, banded, fibrous and, to a lesser extent, as euhedral crystals. Diameter of nodular colemanites may reach even up to 40 cm. Nodules are sometimes formed by radial growth from one unique center, and other times multi central growth is observed. Multi central nodules generally occur as an interference of crystal bundles. Small nodules, which compose the larger ones are enclosed by thin clay films. When these nodules are broken, the clay films can be distinguished. Radial crystals show various evolutionary stages during the formation of nodules. Fibrous colemanites establish bands in different horizons. This type of colemanites are pure and white colored. At some instances, these may be confused with ulexite developed in a similar manner. However, ulexite's silky luster and softness are important criteria in distinguishing the two minerals (Helvacı and Dora, 1985).

Due to the late diagenetic influences, fracturing from the center to the marginal parts and solution at the center occurs. Secondary pure, transparent and euhedral colemanite crystals have generated by circulating water within the solution cavities and fractures. Such crystals have also formed in the spaces between different beds.

Although being variable, thickness of massive colemanite beds may reach even up to 5 m. This type of colemanites do not carry so much foreign material; they are rather pure and white in color. However, clayey colemanites exhibit a composite structure together with clay. Ore grade of these colemanites change in relation to the amount of clay contained.

Ulexites exhibit camel's-tooth, nodular and banded structures in the deposits. Camel's-tooth structured ulexites dominantly occur intercalated with clay. Color of this type of ulexites is dirty white. These ulexites, which make very strong and resistant horizons in underground mines, easily disintegrate under atmospheric conditions. Length of the tooth like crystals of camel's tooth ulexite may reach up to 5 cm. Thickness of the ulexite horizons vary from 1.5 to 5 m. at the deposits. Ulexites show a wide distribution especially in the central part of the basin. Proceeding to the margins, ulexite horizons end up in lenses and colemanite becomes dominant. Banded ulexites are composed of thin, radial crystal fibers, developed perpendicular to band walls. Due to their more compact texture, they are harder than camel's-tooth ulexites. Banded ulexites with silky luster are pure and light colored. In the case of nodular ulexites, mostly multi central radial crystal bundles occur intersecting each other. Finally, these crystal bundles form a big nodule. These nodules occasionally lose their radial character and gain a massive structure.

Secondary ulexite has developed in the fractures and cavities, formed during and after late diagenesis. These ulexites with a distinct silky luster contain no impurity. Thickness of these ulexites, which usually cut the bedding plane, may reach as much as 10cm.

Gradation from colemanite into ulexite is mostly very sharp but sometimes gradational transition also occurs. At the gradational transition zones, colemanite and ulexite have grown together.

### **Non-economic boron minerals**

Inyoite, one of the non-economic boron minerals occurring at the Bigadiç area, is observed as uniform and transparent crystals. This mineral occurs together with colemanite in the Acep and Kireçlik deposits.

Yellowish white colored meyerhofferite occurs in a net-texture, generally composed of regularly oriented crystals and occasionally nodules with radial structure. It is observed in the Avşar, Simav and Kireçlik deposit together with colemanite.

Table 1- Boron minerals determined at the productive deposits in the Bigadiç basin

| DEPOSITS<br>MINERAL NAME |  | UPPER BORATE BEARING ZONE |       |      |          |            |          |            |         | LOWER BORATE BEARING ZONE |  |
|--------------------------|--|---------------------------|-------|------|----------|------------|----------|------------|---------|---------------------------|--|
|                          |  | AVŞAR                     | SİMAV | ACEP | ÖNGÜNEVİ | ARKAGÜNEVİ | KİREÇLİK | KURTPINARI | YENİKÖY | TULU                      |  |
| Colemanite               |  | +                         | +     | +    | +        | +          | +        | +          | +       | +                         |  |
| Ulexite                  |  | +                         | +     | +    | +        | +          | +        | +          | +       | +                         |  |
| Meyerofferite            |  | +                         | +     | +    |          |            | +        |            |         |                           |  |
| Inyoite                  |  |                           |       | +    |          |            | +        |            |         |                           |  |
| Pandermite               |  |                           | +     |      |          |            |          |            | +       |                           |  |
| Tunellite                |  |                           |       |      | +        |            |          |            |         |                           |  |
| Howlite                  |  |                           |       |      |          |            |          |            | +       |                           |  |
| Hydroboracite            |  |                           |       |      | +        |            |          |            | +       |                           |  |
| Proberite                |  |                           |       |      | +        |            |          |            | +       |                           |  |

Table 2- Chemical analysis of colemanite and ulexite ores produced from the deposits in the Bigadiç basin

| MINERAL NAME           | B <sub>2</sub> O <sub>3</sub> | Fe <sub>2</sub> O <sub>3</sub> | Al <sub>2</sub> O <sub>3</sub> | SiO <sub>2</sub> | SiO <sub>2</sub> | SiO <sub>2</sub> | BeO   | CaO  | MgO   | Na <sub>2</sub> O | K <sub>2</sub> O | P <sub>2</sub> O <sub>5</sub> | KK*   | Cu    | Ni    | Zn    | Pb    | Mn    | As    | S     |  |
|------------------------|-------------------------------|--------------------------------|--------------------------------|------------------|------------------|------------------|-------|------|-------|-------------------|------------------|-------------------------------|-------|-------|-------|-------|-------|-------|-------|-------|--|
| COLEMANITE             |                               |                                |                                |                  |                  |                  |       |      |       |                   |                  |                               |       |       |       |       |       |       |       |       |  |
| Avşar                  | 35.85                         | 0.07                           | 0.04                           | 8.94             | 0.98             | 0.31             | 26.21 | 4.18 | 0.14  | 0.03              | 0.01             | 23.96                         | 0.02  | 0.01  | 0.015 | 0.005 | 0.005 | 0.01  | 0.007 | 0.02  |  |
| Simav (I. damar)       | 30.67                         | 0.06                           | 0.07                           | 10.46            | 0.84             | 0.33             | 27.70 | 4.54 | 0.064 | 0.03              | 0.01             | 25.56                         | 0.003 | 0.003 | 0.005 | 0.004 | 0.003 | 0.009 | 0.008 | 0.01  |  |
| Yeniköy                | 24.01                         | 0.06                           | 0.03                           | 7.12             | 0.28             | 0.43             | 38.35 | 2.99 | 0.064 | 0.04              | 0.02             | 29.10                         | 0.005 | 0.005 | 0.005 | 0.02  | 0.01  | 0.16  | 0.006 | 0.01  |  |
| ULEXITE                |                               |                                |                                |                  |                  |                  |       |      |       |                   |                  |                               |       |       |       |       |       |       |       |       |  |
| Avşar                  | 31.92                         | 0.05                           | 0.12                           | 10.32            | 1.24             | 0.23             | 16.72 | 5.46 | 3.96  | 0.04              | 0.01             | 29.01                         | 0.003 | 0.01  | 0.003 | 0.003 | 0.003 | 0.007 | 0.006 | 0.01  |  |
| Simav                  | 33.71                         | 0.03                           | 0.04                           | 7.71             | 0.51             | 0.20             | 16.14 | 4.21 | 4.88  | 0.03              | 0.01             | 30.21                         | 0.005 | 0.003 | 0.003 | 0.003 | 0.003 | 0.007 | 0.006 | 0.01  |  |
| Yeniköy                | 30.97                         | 0.05                           | 0.13                           | 8.74             | 0.32             | 0.22             | 20.15 | 4.56 | 3.97  | 0.04              | 0.01             | 30.36                         | 0.005 | 0.003 | 0.003 | 0.003 | 0.003 | 0.006 | 0.006 | 0.01  |  |
| Yeniköy                | 24.09                         | 0.12                           | 0.33                           | 12.15            | 0.28             | 0.31             | 22.73 | 6.59 | 2.87  | 0.07              | 0.02             | 31.06                         | 0.005 | 0.002 | 0.005 | 0.004 | 0.004 | 0.01  | 0.006 | 0.01  |  |
| Öngünevi (Tb Ulexite)  | 44.19                         | 0.05                           | 0.01                           | 1.58             | 0.56             | 0.18             | 13.41 | 0.55 | 6.10  | 0.01              | 0.01             | 29.99                         | 0.02  | 0.005 | 0.007 | 0.004 | 0.004 | 0.005 | 0.006 | 0.001 |  |
| Öngünevi (Tv Ulexite)  | 40.15                         | 0.02                           | 0.02                           | 5.20             | 0.38             | 0.19             | 13.89 | 2.00 | 5.35  | 0.02              | 0.01             | 29.38                         | 0.006 | 0.006 | 0.003 | 0.003 | 0.003 | 0.004 | 0.007 | 0.03  |  |
| Arkağnevi (Tv Ulexite) | 37.71                         | 0.04                           | 0.05                           | 11.40            | 0.45             | 0.18             | 12.15 | 4.89 | 4.86  | 0.04              | 0.01             | 27.45                         | 0.004 | 0.01  | 0.003 | 0.003 | 0.003 | 0.006 | 0.01  | 0.01  |  |
| Arkağnevi              | 39.73                         | 0.03                           | 0.03                           | 6.40             | 0.42             | 0.17             | 12.24 | 2.96 | 5.80  | 0.03              | 0.01             | 29.31                         | 0.003 | 0.01  | 0.003 | 0.003 | 0.003 | 0.005 | 0.009 | 0.025 |  |
| Arkağnevi              | 39.73                         | 0.03                           | 0.03                           | 6.84             | 0.36             | 0.17             | 12.30 | 2.97 | 5.65  | 0.03              | 0.01             | 29.06                         | 0.005 | 0.01  | 0.003 | 0.003 | 0.003 | 0.004 | 0.008 | 0.03  |  |
| Kireçlik (Tv Ulexite)  | 34.98                         | 0.02                           | 0.01                           | 10.36            | 0.72             | 0.21             | 11.98 | 5.40 | 4.86  | 0.04              | 0.01             | 28.54                         | 0.004 | 0.01  | 0.003 | 0.003 | 0.003 | 0.006 | 0.006 | 0.04  |  |
| Kireçlik (Tb Ulexite)  | 37.56                         | 0.04                           | 0.03                           | 9.74             | 1.35             | 0.21             | 13.07 | 4.24 | 4.08  | 0.04              | 0.01             | 30.32                         | 0.003 | 0.01  | 0.003 | 0.003 | 0.003 | 0.005 | 0.005 | 0.04  |  |

\* KK = Loss on Ignition (H<sub>2</sub>O+CO<sub>2</sub>)

Pandermite is a fine crystalline, milky white colored mineral. At some localities, it exhibits a hard, horn like structure, but upon disintegration turns into a kaolin like mass. The mineral occurs together with colemanite in the Sirnav, Mezarbaşı and Yeniköy deposit.

Dirty yellow and dirty white colored probertite generally occurs as radial crystals. Infra crystalline spaces are mostly filled with clay. The mineral occasionally forms 20-30 cm. thick bands in ulexite veins. Probertite is determined in the deep drill cores from Öngünevi, Arkagünevi and lower borate ore zones.

Hydroboracite is white colored and occurs in masses composed of randomly oriented needles from a common center. These needles intersect with each other. Hydroboracite is derived from colemanite and forms thin horizons within the interbedded clay. The mineral is determined in the Öngünevi, Arkagünevi and Kireçlik deposit.

Tunellite is colorless and transparent. The crystals resemble muscovite flakes and show parallel cleavage. The mineral is derived from ulexite by lateral segregation, and commonly occurs within ulexite as transparent packs of thin platelets. It occurs in the Öngünevi and Arkagünevi deposits.

The lower borate ore zone, in particular, carries howlite bearing horizons. The mineral is white colored, compact and finely nodular. Small nodules of howlite tracing a certain horizon occur together with colemanite in the clays alternating with colemanite in the Kurtpinarı open pit, in the upper borate bearing unit.

### Ore formation mechanism

Bigadiç borate deposits have formed in independent or interconnected playa lakes, located in areas where volcanic activity had been effective and supplied hydrothermal solutions and thermal water, under arid or semiarid climatic conditions. The deposits are interbedded with tuff, tuffite, claystone, marl and limestone. Bigadiç borate deposits occur in two separate zones, between which the upper tuff unit has deposited (Helvacı and Alaca, 1984).

In both of the zones, colemanite and ulexite are more dominant than other boron minerals. Thus, colemanite and ulexite are the principal ore minerals, while howlite, inyoite, hydroboracite, tunellite, pandermite and probertite remain as accessory minerals of no economic significance. For this reason, it is more convenient to discuss the composition of a borate deposit in a triple system, with the end members being CaO- Na<sub>2</sub>O-B<sub>2</sub>O<sub>3</sub>.

As the precipitation of borates follows the chemical precipitation of carbonaceous sediments, due to the abundance of Ca<sup>++</sup> in the playa lake water, first Ca-borates should normally precipitate. Together with Ca-borate precipitation, an enrichment of Na<sup>+</sup> takes place in the lake water. Thus, Ca-Na-borates start to precipitate as the process continues, and evaporation rate increases. Na-borates have not precipitated in the Bigadiç basin. The reason is probably the lack of sufficient Na<sup>+</sup> within the solutions feeding the basin. This resulted in the precipitation of another Ca-Na-borate sequence. By the alternation of these processes, Bigadiç borate deposits have formed.

Colemanite formation by the transformation of ulexite, which was suggested first by Foshag (1921) for the Californian deposits, does not seem to prevail in the Bigadiç basin, because of the following reasons. First of all, no trace of colemanite with ulexite precursor could be determined anywhere. Na<sup>+</sup> enrichment of clays, in alternation with colemanites at Bigadiç, does not exist (Helvacı, 1989). On the other hand, if the following chemical reaction occurred by an exchange of bases between ulexite and clays, the clays should be enriched in Na<sup>+</sup>, theoretically:

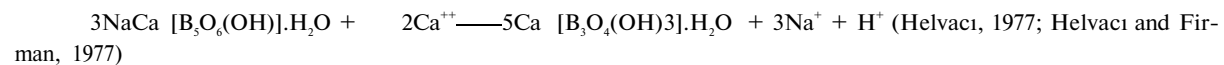

Colemanite-borax mineral couple formation thesis due to the disintegration of ulexite is not applicable to the Bigadiç borate basin, because Na-borate minerals could not be determined here (Helvacı, 1977, 1983; Helvacı and Alaca, 1984).

Colemanites at Bigadiç have not formed by the dehydration of inyoite under burial and diagenetic influence, because inyoite mineral cannot be found in every part of the basin, and pseudomorphic transformations of inyoite have not been determined (Helvacı and Alaca, 1984).

Colemanites occurring in the basin are possibly the primary precipitates from solutions and are contemporaneous to sedimentation, and they have formed within the unconsolidated sediments under the sediment/water interface (Helvacı, 1977, 1984, 1986; Helvacı and Alaca, 1984).

Precipitation of ulexites also occurred in a similar manner, in the period following the Ca-borate precipitation, when the Na<sup>+</sup> concentration of the solution increased (Helvacı and Alaca, 1984).

Secondary idiomorphic colemanite and ulexite have formed by the circulation of solutions rich in boron, along the fractures and cavities, that were produced during late diagenesis, and by the disintegration of primary minerals.

Meyerhofferite occurs together with colemanite. No transformation of this mineral into another one or vice versa has been observed.

Hydroboracite, on the other hand, has formed by the transformation of colemanite. In this transformation, just the replacement of Ca<sup>++</sup> by Mg<sup>++</sup>, and addition of water are sufficient:

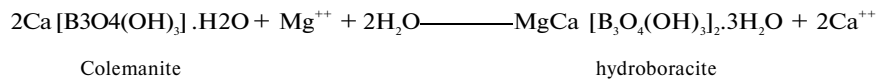

(Helvacı, 1977; Helvacı and Firman, 1977).

This reaction may proceed in the initial stages of diagenesis by base exchange between Mg<sup>++</sup> rich luff and clays (Helvacı, 1977; Helvacı and Firman, 1977; Helvacı and Alaca, 1984).

Howlite crystals have developed within the clays alternating with thin colemanite bands, and reflect a period when Si concentration increased. Due to compaction and diagenesis, small howlite nodules were embedded into still loose colemanite ore (Helvacı and Dora, 1985).

Some ulexite horizons, especially those in the lower borate ore zone, carry probertite bands. These minerals, which generated under the same chemical conditions with ulexite, represent a stronger evaporation period at the playas (Helvacı and Dora, 1985).

In the Sr rich ulexite horizons, solution and recrystallization gave rise to the formation of lunellite.

Clay minerals are capable of retaining 310 ppm or more boron (Goldschmidt, 1954). Thus, significant amount of boron may have deposited together with clays, and nodular ore formed later within clays, by the influence of circulating boron rich solutions.

Mode of occurrence of Bigadiç borate deposit is schematized in Figure 22.

#### Alteration

Widespread alteration can be traced in the ore veins at deposits and trenches, where exploitation is carried out. The mass of altered ore is termed as "Şekerleme" (candy) locally (Helvacı, 1989). For colemanite, this alteration may be expressed with the following equation:

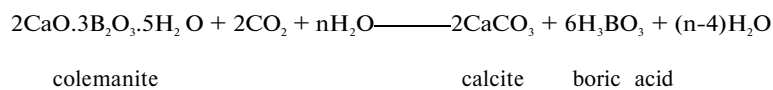

In general, regular borate horizons are interrupted by alteration, and this also makes the tracing of veins within the ore zone difficult.

Alteration is important especially for the upper borate ore zone. It is not so widespread in the lower borate ore zone, because it generally occurs where erosion and tectonism are active, and underground water mobile (Helvacı, 1989). As thick units overlie the lower borate bearing zone and have protected it against erosion, this ore zone remained without altered.

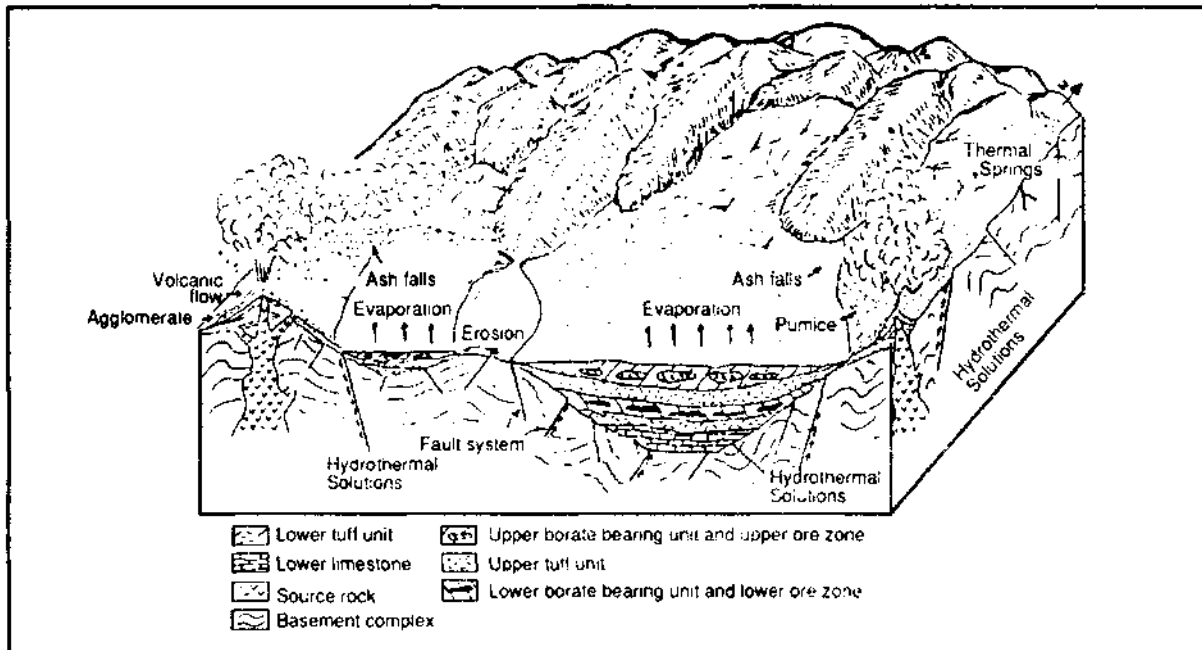

Fig. 22 - Formational model of Bigadiç borate deposits.

Wall rocks and gangue minerals

Maximum thickness of the ore zone in the lower borate bearing unit is 76.00 m. and that in the upper borate bearing unit is 80.00 m. Ore horizons within these zones are accompanied by clay, marl, tuff, limestone, calcite, gypsum and anhydrite. Different grades of ore has formed due to the distribution of these sediments in the ore horizons and zones, together with the physical properties of ulexite and colemanite.

Gypsum, anhydrite, calcite, aragonite and clay occur in the basin as gangue minerals. Gypsum is found particularly in deep borcholes of lower borate, as bands between ore horizons in Avşar, Simav, Ön and Arkagünevi deposits and as intercalations within the ore. Anhydrite accompanies colemanite in the lower borate bearing unit. Clay occurs as bands between the ore veins and as laminated alternations with limestone. It may also appear in a composite structure together with colemanite and ulexite.

RESULTS

Sequence of lithologic units in the study area, in ascending order from bottom to top is as follows: basement rocks, basement volcanics unit, basement limestone unit, lower tuff unit, lower borate bearing unit, upper tuff unit, upper borate bearing unit, basalt, recent sediments and alluvium.

Borate deposition in the study area occurs as two separate horizons in the lower and upper borate bearing units. The upper tuff unit of thickness 300-350 m. is set between these units.

Boron minerals of the lower borate ore zone are colemanite, ulexite, howlite, probertite and hydroboracite. Colemanite, ulexite, inyoite, meyerhofferite, pandermile, probertite, hydroboracilic, howlite and tuncellite have been determined in the upper borate zone. In both zones, colemanite and ulexite are more dominant than the others.

Thickness of the lower borate ore zone varies between 0.2-76.00 m. and that of the upper borate ore zone between 0.15-80.00 m.

Ore zone in the lower borate unit is closer to the basement of the unit, while the ore zone in the upper borate ore zone is located at the middle part.

Tuff bands between the ore veins are more common in the lower borate ore zone, compared to the upper borate ore zone.

Reddish brown, soapy clays overlying the lower borate ore zone act as reference levels for the lower borate ore zone.

Colemanites at the Bigadiç borate basin are possibly primary precipitates from the solution, and they are contemporaneous with sedimentation. They have precipitated in the unconsolidated sediments under the sediment/water interface.

Ulexite precipitation is similar to that of colemanite and represent the periods when Na<sup>+</sup> concentration of the solution increased during Ca-borate deposition.

Secondary idiomorphic, pure and clean colemanite and ulexite were formed by the circulation of boron rich solutions, in the fractures and cavities developed during late diagenesis and by the solution of primary minerals.

Borates are accompanied by non borate minerals at the ore zones. Borates are generally found together with clays, marl, tuff, limestone, gypsum, anhydrite and dolomite.

Borate beds, which show regular extension in general, are interrupted locally due to alteration, and this process also makes the tracing of veins in the ore zone difficult.

B<sub>2</sub>O<sub>3</sub> content of colemanites range among 24.01 % - 35.85 %, while that of ulexites among 24.09 % - 44.19 %, at the productive mines.

#### ACKNOWLEDGEMENT

Authors wish to thank Etibank's directors and technical staff, at the General Directorate and mine site, for their close attention during the investigation of the deposits. Also thanks are extended to F. Akgün, who determined the pollen species; S. Karamımak, who drew the figures, and M. Akdere, who typed the manuscript with great care.

*Manuscript received October 20, 1989*

#### REFERENCES

- Alaca, O.; İşintek, İ.; Selvi, A. and Kurul, A., 1987, Bigadiç borat havzası batı kesiminin jeolojik incelemesi: Etibank Rep. (unpublished), 37 p., 12 app., Ankara.
- Bekişoğlu, K.A., 1961, Türkiye'de bor yatakları ve bunların aracılığı ehemmiyet: MTA Rep. 3400 (unpublished), Ankara.
- Borsi, S.; Ferrara, G.; Innocenti, F. and Mazzouli, R., 1972. Petrology and geochronology of recent volcanism of eastern Aegean Sea: Bull. Volcanol., 36. 473-496.
- Çakır, A. and Dündar, A.. 1982. Balıkesir-Bigadiç boratlı Neojen incelemesi hakkında ön rapor: MTA Rep. 7075 (unpublished), Ankara.
- Foshag, W.F.. 1921. The origin of the colemanite deposits of California: Econ. Geol. 16. 199-214.
- Goldschmidt, V.M., 1954, Geochemistry: Oxford University Press, Oxford.
- Gündoğdu, M.N., 1982, Neojen yaşlı Bigadiç sedimanter baseninin jeolojik, mineralojik ve jeokimyasal incelenmesi: Hacettepe Üniversitesi Ph. D. Thesis. 386 p., 3 app., (unpublished), Ankara.
- Helvacı, C., 1977, Geology, mineralogy and geochemistry of the borate deposits and associated rocks at the Emet Valley, Turkey: Ph.D. dissertation. University of Nottingham, England.
- , 1983, Türkiye borat yataklarının mineralojisi: Jeo. Müh. Bull.. 17, 37-54.



- Helvacı, C., 1984, Occurrence of rare borate minerals: Veatchite-A, tunellite, teruggite and cahnite in the Emet borate deposits, Turkey: Mineral. Deposit, 19.217-226.
- , 1986, Emel borat yataklarının kökeni ve jeokimyası: Cumhuriyet Üniversitesi Eng. Fac. Bull., Serie A-Farthsciences V. 3, no. 1, p. 49-73.
- , 1989, Mineralogy and genesis of Bigadiç borate deposits. Western Turkey: 28th International Geological Congress, Washington D.C. USA, 2. 49-50.
- , 1989, Türkiye bor madenciliğinin işletme, stoklama ve pazarlama sorunlarına mineralojik bir yaklaşım: Jeo. Müh. Bull., p. 34-35, 5-17.
- and Alaca, O., 1984, Bigadiç borat yataklarının jeolojisi ve mineralojisi: TJK 38. Bilimsel ve Teknik Kurultayı Bildiri **Özleri**, 110-111.
- and Dora, Ö., 1985, Bigadiç borat yataklarında mineral oluşumları hakkında yeni görüşler: TJK 39. Bilimsel ve Teknik Kurultayı Bildiri **Özleri**, 75-76.
- and Firman, R.J., 1977, Emel borat yataklarının jeolojik konumu ve mineralojisi: Jeo. Müh. Bull., 2, 17-28.
- ; İnci, U.; Yağmurlu, F. and Yılmaz., H., 1987, Batı Anadolu Neojen stratigrafisi ve ekonomik potansiyeli: Akdeniz University Isparta Müh. Fak. Bull.. Jeoloji 3, 31-45.
- Helke, A., 1955, Beobachtungen an Türkischen minerallagerstätten II. N. Jb. Min. Abh., p. 178-180.
- Kalafatçıoğlu, A., 1964, Balıkesir-Kütahya arasındaki bölgenin jeolojisi: Türkiye Jeol. Kur. Bull., 9, 46-63.
- Kutlu, R., 1963, M. Ali Meydan'a ait bortuzu ruhsat sahası (Balıkesir): MTA Rep.. 1011, (unpublished), Ankara.
- Mcixner, H., 1952, Einige boratemmerale (colemanit und tertschit ein mineral) aus der Türkei: Fortschr. Mineralogie, 31, p. 39 42.
- , 1953, Neue turkische boratlagerstätten: Berg. u. Hüttenman, Monatsch. 98, p. 86-92.
- , 1956, Die neue turkische boratprovinz un İskeleköy bei Bigadiç im Vilayet Balıkesir: Sonderabdruck aus kali und Steinsals, part 2, p. 43-47, Essen, Verlag Glockkauf.
- Özpeker, I., 1969, Batı Anadolu borat yataklarının mukayeseli etüdü: Ph. D. thesis, İ.T. Univ., 116 p. İstanbul.
- Yılmaz, İ., 1977, Bigadiç bölgesi bazaltik volkanizmasının mutlak yaşı: Doğa Tem. Bil. 1, 210-212, Ankara.