



**Uşak Üniversitesi Fen ve Doğa  
Bilimleri Dergisi**  
Usak University Journal of Science and Natural Sciences

<http://yayinlar.usak.edu.tr/fdb>



*Research article*

## **Significance of Ophthalmic Optics in Opticianry Education at Turkey**

*Gül Yakalı*

*Department of Opticianry Program, Vocational School of Higher Education, Akdeniz University, Turkey*

### **Abstract**

The Opticianry program in Vocational school leads to Optician degree and is usually a post-high school of study of two years duration in Turkey. Historically Opticianry developed out of Physics and/or applied optics programs. Optics, more specifically, ophthalmic optics and its applications to the human eye plays a significant role in the education of an opticianry. In addition, opticians are educated in physical, geometric and visual optics. The ophthalmic optics continues to play a major role in the training and career of an opticianry, especially with the advent of new technologies in treating low vision, measurement and correction of aberrations of the eye, understanding of ophthalmic lenses (spectacle lenses) and how they are designed the correct vision etc. In order to provide this understanding, the essential fundamentals of physical, geometrical, and visual optics are presented as they relate to the eye and vision. In Turkey, opticians are involved in the actual process of making eyeglasses, contacts, and lenses for other purposes. They produce the lenses from scratch to finish according to specifications or prescriptions. Therefore, Ophthalmic Optics in Opticianry education is considerable important science for opticians.

**Keywords:** *Opticianry, optic science, human eye, lenses.*

©2017 Usak University all rights reserved.

### **1. Introduction**

The field of Opticianry probably began at the time when the first spectacles appeared. The first bifocals were devised by Benjamin Franklin in the 18th century in Philadelphia (Lakshminarayanan, 2009). While in the world, education of the profession was developing rapidly (USA started optometry programmes at the universities in 1904) it was carried out in our country as a secondary job next to watch sellers, pharmacies, and jewelers. After foundation of the republic, opticianry started to develop in relation to the reforming process of Turkey. Between the year 1923-1940, opticianry was not omitted in the reforming plans and even a Law has been prepared. This "Law on Opticianry" dated December 30, 1940 and numbered 3953, was composed of 18 Articles, and is considered as the first governmental regulation of opticianry in Turkey. The next law in force was Law no: 3958 and it was describing the profession, the rules of performing it and specified the prohibitions related to it. However, there was no directive of this law

\*Corresponding author:

E-mail: [gulyakali@akdeniz.edu.tr](mailto:gulyakali@akdeniz.edu.tr)

existent, which made it impossible to determine details of practice. The law was stating that the profession may be carried out only by licensed opticians and has set the requirements to get a license from the Ministry of Health. 1989, the Institute for Higher Education of Turkey, has decided to start Opticianry Programmes as a pre-bachelor degree course in their faculties. The first of such courses started at the University of Sivas, in 1992. Until the year 2004, the course had 700 graduates (optician degree). But since the Law in force was not amended, these graduates had no right to practice as opticians for 12 years. On 22.June.2004, the government has set in force the new Law on Opticianry and the related Directive. After that, the profession was based on university education and won a new and modern approach in Turkey. After enforcement of the new Law, the 700 graduates from the period between 1992 and 2004 obtained their right to practice and establish optic shops (Türk Optik ve Optometrik Meslekler Derneği, 2014).

As noted earlier, ophthalmic optics being the historical basis of opticianry, plays a major role in the education of an optician. In Turkey, the students of opticianry is trained in several aspects of optics. These can be classified as : geometric, physical, ophthalmic and visual optics. The website for National Board of Examiners in Optometry ( NBEO) gives a detailed listing of the areas covered in the optics section (NBEO, 2007). In this article, it is mentioned that, importance of ophthalmic optics in opticianry education in Turkey.

## **2. Ophthalmic Optics In The Opticianry Programme In Turkey**

Ophthalmic means “of or pertaining to the eye”. So, ophthalmic optics includes any optics that related to the eye. Technically, this includes spectacle lenses, the optics of the eye itself, contact lens, intraocular lenses, and optical instruments used to examine the eye (Meister and Sheddy, 2007). In epitome, ophthalmic optics deals with optical elements that are employed to improve vision. The essentialness for such improvement may arise from the presence of a refractive error or any other visual defect, a particular or professional demand for increased retinal image size, increased image contrast. In addition, protective filters are included within the scope of ophthalmic optics.

Materials for ophthalmic optics are mainly glass and plastics. Contact and intraocular lenses are all made of plastic (Ophthalmic Optics Jose Alonso Javier Alda University Complutense of Madrid). Similarly for spectacle lens plastic which are usually coated to improve their scratch resistance is more useful than glass. Because, the plastic spectacle lens is more durable than glass spectacle lens.

In this work, it is begun that with the description of the eye–lens system. Ophthalmic optics does not account for the characteristics of the human eye. The study of the design and performance of the ophthalmic optical systems requires the knowledge of the optics of the eye and utilization of its anatomical and physiological characteristics.

The human eye can be considered as an optical system with a positive power of about 58 D (Bennett ve Rabbetts, 1984; Legrand and El Hage, 1980; Pedrotti and Pedrotti, 1998) . There are three basic parts of the eye: a light focusing system, an automatic aperture system, and a light sensitive detection system. In the light focusing system, the cornea and the lens responsible for the refractive power of the eye. The main refracting element of the human eye is the cornea whose first surface is in contact with air, it bears most of the power of the eye (about 45 D). The muscles controlling the curvature of the lens provide the flexible focusing power of the eye (13 D). Real inverted images are formed on a layer of photosensitive tissue called the retine by these optical elements of the eye. In a briefly, the human eye is similar to a camera and has a dark interior chamber, a variable

aperture (called the pupil) to control retinal illuminance and the lens which enables adjustable focusing (showing Figure 1) (Fannin and Grosvenor,1996).

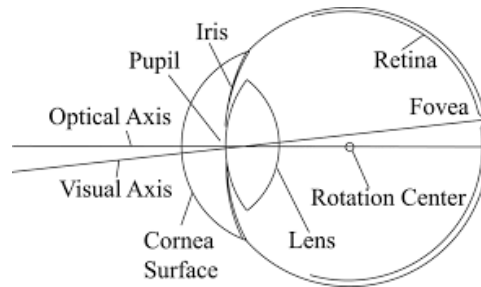

**Figure 1.** Anatomy of human eye

In the optical human eye system, real image is focussed in fovea (The fovea is responsible for sharp central vision at retina). In this case, the eye is called emetrop. Emmetropia is defined as the condition for which the relaxed eye (without accommodation) images a distant object onto the retina (fovea). However when the image is focussed in front of or in behind or any point of the fovea, the human eye is called ametrop eye. The condition in which a refractive error occurs is called ametropia. Therefore the defect is occur in the human eyes. The most common defects of human vision include the light refracting system of the eye. Normal vision provides clear vision for letters that subtend three minutes of arc at a distance of 6.10m from the observer. If a person requires letters at 6.10 m that normal vision reads at 12.2m the person is said to have 20/40 visual acuity. Normal visual acuity is expressed as 20/20 vision (Westheimer, 1987).

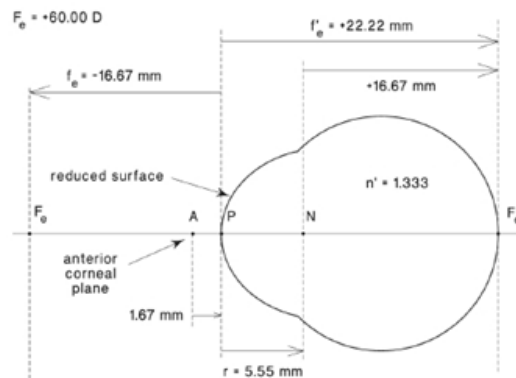

**Figure 2.** Schematic structure of human eye. (N: nodal points, P:prensibal points, F: odak points)

Ametropia is categorised by the specific type of optical deficiency or refractive error. In hyperopia, the image of the distant object forms behind the retina as a result of any of the following reasons: the eye does not attain enough power or is too small, combination of both. In case the refractive error is smaller than the amplitude of accommodation (accommodation: the lens of the human eye can increase the overall focal power up to +70 D or more). Plus lenses (that is thicker in the middle than at the edges and are described as converging or positive lenses) can be used to correct it. In myopia the image of a distant object forms in front of the retina because the eye is too powerful, too large,

or both. It can be corrected with minus lenses ( that is thinner in the middle than at the edges and are described as diverging or negative lenses). These two refractive errors are called spherical ametropia. In astigmatizm which can be corrected by lenses with cylinder power , the eye shows different powers (dioptria) at different meridian planes.This error is occurred difference of both prensibal axis of cornea. In presbiyopia the amplitude of accommodation reduces with age and along with it, the ability to focus near objects. At this stage, it is used to near spectacle lenses (plus lenses) (33 cm) with patients. A lens placed in front of the eye compensates for its ammetropia when the image focal point of the lens coincides with the remote point of the eye. This compensation principle applies only for the situation in which; the lens axis passes through the rotation center of the eye, and the lens axis coincides with the eye visual axis(Jalie, 1999; Keating, 1992) ].

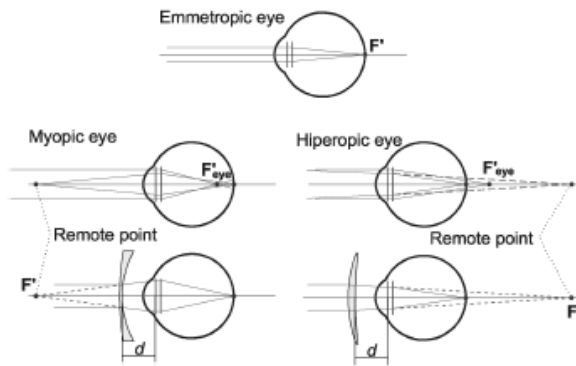

**Figure 3.** Principle of compensation and lens adaptation

When the patients is ammetropia they want to have lens about refractive error. At stage, lens form and thickness ( which is the final centre or edge thickness of the lens after surfacing, finning and polishing) are very important for them. Patients buy new lens may want an estimate of the lens thickness. The height of the curvature of a surface is referred to as sagitta or simply sag, of that curve (Meister, 1997). This value will vary with the both radius of curvature and diameter of lenses. Before the eye wear is delivered to patients, the sagitta of the lens must be determined.( Showing Figure 4)

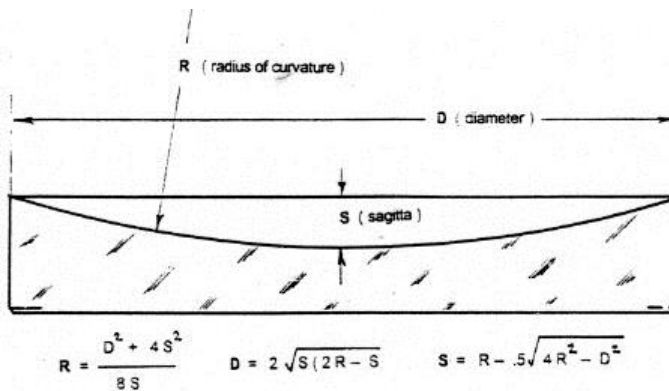

**Figure 4.** Determination of lens sagitta

At some eye diseases for example; strabismus( patients with esotropic, exotropic, hypotropic, hypertropic), the ophthalmic prisms are used . Prism is often incorporated into spectacle lenses for to compensate for anomalies of binocular vision (refers to ability to use the two eyes together when viewing an object), to decenter the optical enter, to reduce thickness progressive lenses. (Showing Figure 5) (Harris ,1994).

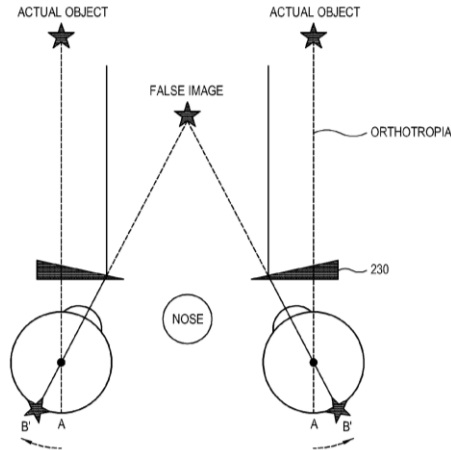

**Figure 5.** Prism is incorporated into spectacle lenses for to compensate for anomalies of binocular vision

The lens optical axis does not coincide with the visual axis, and aberrations have to be introduced. There are two primary causes of non-ideal lens action: Geometrical or Spherical aberrations are related to the spherical nature of the lens and approximations used to obtain the Gaussian lens equation; and Chromatic aberrations, which arise from variations in the refractive indices of the wide range of frequencies found in visible light. Abbe sayısı of the lenses is concerned chromatic aberration[15].

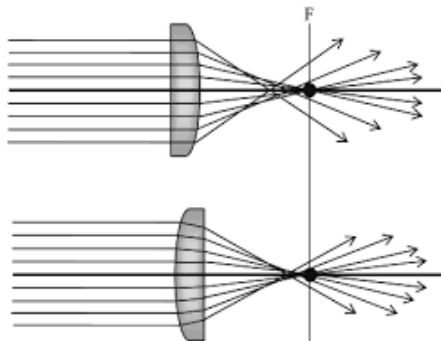

**Figure 6.** Showing of spherical aberration

In ophthalmic lenses, the primary purpose of the spectacle frame or mounting is to comfortably support and accurately position the spectacle lens in front of the eyes ( showing boxing system Figure 7). To accomplish this task the frames must be durable and properly fit. Key frame components are rims/eyewires (surround and support the

lens), bridge pieces ( connects two rims together), temples ( extend to the ears for support). Collectively these points are known as the fitting triangle (Atchinson, 1992).

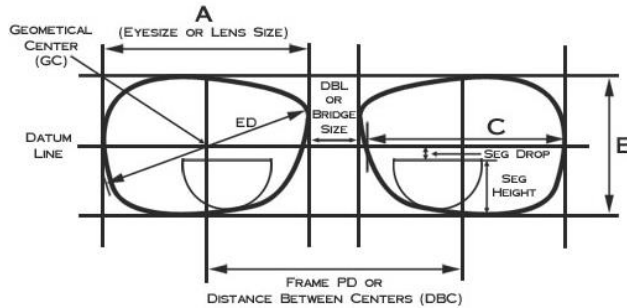

Figure 7. The boxing system

#### 4. Conclusion

Ophthalmic optics are the most important field in the opticianry education. Especially with the advent of new technologies in treating low vision, measurement and correction of aberrations of the eye, understanding of ophthalmic lenses (spectacle lenses) and how they are designed the correct vision etc. However, plainness in design of ophthalmic lenses needs to be settled to the anatomical and physiological constraints exposed by the eye. The design needs to improve optical performance in terms of minimization of optical aberrations involved mainly field. At the same time, the results should also take into aesthetic and ergonomic criteria. Knowledge of the compound eye- lens system, along with the basis of the design of ophthalmic lenses, must be used in the final adaptation of the ophthalmic lens for a given user. Therefore, opticians who learned the ophthalmic optics are very important professionals in relation to protect the vision health of the Turkish community. If opticians are educated well in terms of ophthalmic optics, they will contribute to the whole optic sector, technology as well as the national economy. In order to provide better services in vision health protection, it is essential that parallel to the programmes in universities, the knowledge and education of the present opticians is improved.

#### References

1. Lakshminarayanan, V. (2007). Teaching optics in a multi-disciplinary curriculum: experience from optometry programs. *In Education and Training in Optics and Photonics*. Optical Society of America.
2. Türk Optik ve Optometrik Meslekler Derneği. *Genel Bilgiler*. (2014) [Online] [http://www.gozder.com/panel/eskiDosyalar/b\\_uploadedFiles/files/aydin\\_tr.pdf](http://www.gozder.com/panel/eskiDosyalar/b_uploadedFiles/files/aydin_tr.pdf)
3. NBEO-National Board of Examiners in Optometry, (2007), [www.optometry.org/pdf/contents/Optics.pdf](http://www.optometry.org/pdf/contents/Optics.pdf)
4. Meister, D. and Sheddy, J. E. (2008). *Introduction to Ophthalmic Optics*. SOLA Optical USA.
5. Alonso, J. and Alda, J. (2003). *Ophthalmic Optics*. Alda University Complutense of Madrid, Spain.
6. Bennett, A.G. and Rabbetts, R.B. (1984). *The Eye's Optical System*. In *Clinical Visual Optics*; Butterworths: London, 7-21.
7. Legrand, Y. and El Hage, S.G. (1980). *Optics of the Eye*. In *Physiological Optics*; Springer Verlag: Berlin, 7-21.

8. Pedrotti, L.S. and Pedrotti, F.L. (1998). *Optics of the Eye*. In Optics and Vision; Prentice Hall: New Jersey, USA, 194–221.
9. Fannin, T.E. and Grosvenor, T. (1996). *Clinical Optics*. 2nd Ed.; Butterworth Heinemann: Boston, USA.
10. Westheimer, G. (1987). Visual Acuity. In *Adler's Physiology of the Eye*. 8th Ed.; Moses, R.A., Hart, W. M., Jr., Eds.; The C.V. Mosby Company: St. Louis, USA, 415–428.
11. Jalie, M. (1999). *Ophthalmic Lenses and Dispensing*. Butterworth Heinemann: Oxford, UK.
12. Keating, M.P. (1992). *Geometric, Physical and Visual Optics*; Butterworth: Boston, USA.
13. Meister D. (1997). *Methods for Estimating Lens Thickness*. 26, 201.
14. Harris, W.F. (1994). Prismatic effect in bifocal lenses and the location of the near optical centre. *Ophthalmic Physiol. Opt.*, 14, 203–209.
15. Polat N. and Aydın E. Y., Tuncer İ. (2014). Optical Aberrations and Wavefront. *Turk J Ophthalmol* 44, 306-11
16. Atchinson, D.A. (1992). Spectacle lens design: A review. *Appl. Opt.*, 31, 3579–3585.