



## Sakarya University Journal of Science

ISSN 1301-4048 | e-ISSN 2147-835X | Period Bimonthly | Founded: 1997 | Publisher Sakarya University |

<http://www.saujs.sakarya.edu.tr/>

Title: Passive RFID Uplink and Downlink Link Budget and Comparison of ASK and BPSK Backscatter Modulations

Authors: Kazım Evecan

Received: 2018-06-18 16:22:41

Revised: 2018-09-21 14:27:17

Accepted: 2018-10-11 11:28:03

Article Type: Research Article

Volume: 23

Issue: 1

Month: February

Year: 2019

Pages: 66-75

How to cite

Kazım Evecan; (2019), Passive RFID Uplink and Downlink Link Budget and Comparison of ASK and BPSK Backscatter Modulations. Sakarya University Journal of Science, 23(1), 66-75, DOI: 10.16984/saufenbilder.434517

Access link

<http://www.saujs.sakarya.edu.tr/issue/38708/434517>

New submission to SAUJS

<http://dergipark.gov.tr/journal/1115/submission/start>

## Passive RFID the Forward and Backward Link Budgets and Comparison of ASK and BPSK Backscatter Modulations

Kazım Evcan\*<sup>1</sup>

### ABSTRACT

Reflected signal levels in passive RFID require separate TX and RX antennas to overcome the reader threshold. Using latest improvements, it is shown in this work that both the forward and backward links restrict communication distance given with equations depending upon tag power dissipation, antennas in use, type of modulation and operating environment and parameters to make both distances equal are given. Complete link budget for the forward and backward links in a RFID system are given with constituent parts in detail. After that, to further elaborate on the link budgets, reflection coefficient and power equations are obtained from a RFID front-end model with circuit theory and shown on a passive RFID system. This study shows modulation index  $m$  and antenna gain  $G_t$  for BPSK and ASK modulations to make two distances equal for the environment to be within, found from two way link equations. Also, ASK and BPSK modulations are compared on communication distance for given average backscatter difference power, minimum SNR to targeted BER on the reader by the equations obtained on the circuit model and MATLAB simulations.

**Keywords:** RFID, RFID link budget, communication distance, ASK and BPSK backscatter Modulation, reflection coefficient, transmitted power, reflected power.

### 1. INTRODUCTION

RFID technology has been employed in many promising applications with low cost in various fields, such as access control, biomedical implants, identification, tracking, logistics, sensor networks, security, fast payment system, loss prevention and shopping malls. This technology has a growing potential in massive deployment and retail stores with distant RFID tags working in UHF and microwave bands.

RFID technology is different from conventional transceiver communication systems. In passive RFID systems, reader sends electromagnetic waves to energize tag and to inform key information. After tag obtained enough power to work, tag to reader information is supplied by reflecting incoming electromagnetic waves between two impedance states backscatter modulation. During this operation, tag

switches input impedance between two different states namely matched and short circuit conditions.

Since low amount of power extracted from the field, all the circuit blocks must have low power feature. At UHF and microwave frequencies, tags work from long distance in obstructed and noisy environment and that is why this feature is very essential. On the other hand, the amount of reflected power from this weak incoming field between two impedance states must reach reader and have to be above reader sensitivity or threshold to establish communication channel. As it is understood, in RFID system we have one of two limitations namely reader to tag uplink distance and tag to reader downlink distance.

Communication distance for the forward and backward links are shown with equations and distances for incoming and reflected fields are given in latest studies. In [1], [2] and [3], backscattered power using

<sup>1</sup> Kütahya Dumlupınar Üniversitesi, Elektrik-Elektronik Mühendisliği Bölümü, Kütahya, kazim.evcan@dpu.edu.tr

RCS (radar cross section) is studied with classical radar equation and range equations and tag threshold are given by using RCS. Passive backscatter power for UHF band with RCS equations is shown on RFID front end model for different load conditions and measured in anechoic chamber with network analyzer for short circuit, open circuit and chip loaded conditions in [1]. From these measurements, working distance is found. Communication distance and complete link budget using RCS are shown with typical sample values in [2] and [3]. The forward and backward link budgets are given with example parameters in detail for monostatic and bistatic configurations and different environments in [4] and in reference to the latest RFIDs in the literature and their testing systems at the end in [5]. Passive RFID uplink and downlink design considerations in block level and backscatter modulation schemes with their performance comparisons are presented in [6]. Detailed RF input power and backscattered power equations for BPSK, ASK and OOK are given in [7]. In these studies, nothing is told about making two distances equal in presence of specific operation environment.

In this study, tag power dissipation, antenna gain, reader threshold considering operation environment and modulation parameters included uplink and downlink distances are shown for UHF RFID in detail and parameters to make two distance equal are given. Two way link budgets for UHF RFID with reference to power consuming hardware parts and loss mechanisms is presented in detail in second section. It is shown that reflected signal levels forces to choose bistatic configuration for distant operation. In third section, power equations and reflection coefficient are shown on a RFID front-end model. Backscattered difference power between two states found in section four is used to find minimum SNR and BER for targeted reliability and this SNR value can be used to find reader sensitivity in section five. In last section, with the equations rather than RCS, modulation parameters included uplink and downlink range are found for both ASK and BPSK modulations. It is shown with examples that range is limited with either uplink or downlink depending upon tag power dissipation, antennas in use, reader sensitivity level and modulation type. In addition, modulation index  $m$  and antenna gain  $G_t$  for BPSK and ASK modulations are obtained to make two distances equal.

## 2. LINK BUDGET AND CONSTITUENT PARTS

Each parameter must be utilized effectively or optimized in communication link to maximize communication range. For uplink communication, incident power on the tag antenna must be enough to perform two functions, data extraction and tag energizing, for a communication channel to exist. Incident power is given in (1) for a tag located  $d$  from reader,  $P_t$  transmitted output power from reader,  $G_r$  reader transmit antenna gain with polarization match,  $G_t$  tag antenna gain with polarization match and  $L$  path loss [4]. For lossy environments and free space, path loss  $d$  away from reader is given with (2) and (3),  $n$  path loss exponent ( $n=4-6$  in obstructed buildings,  $n=2-3$  in obstructed factories, etc.),  $d_0$  reference path loss measurement distance and  $\lambda$  wavelength [8].

$$P_{inc} = \frac{P_t G_t G_r}{L} \quad (1)$$

$$L(dB) = L(d_0)(dB) + 10n \log_{10}\left(\frac{d}{d_0}\right) \quad (2)$$

$$L = \left(\frac{4\pi d}{\lambda}\right)^2 = \left(\frac{4\pi d}{c/f}\right)^2 \quad (3)$$

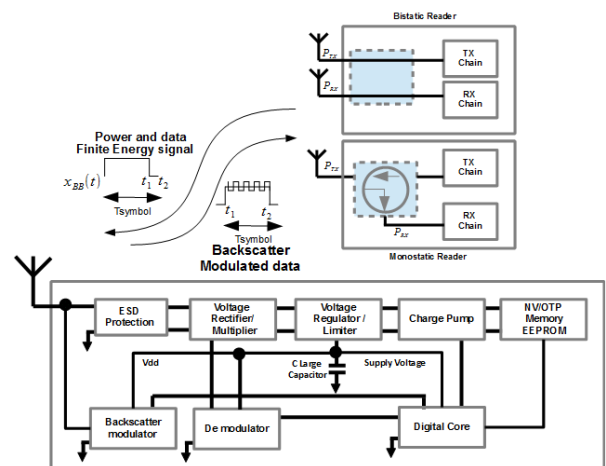

Figure 1. Link budget for a passive RFID system with the same path loss for uplink and downlink [5]

Reader EIRP (equivalent isotropically radiated power) or ERP (effective radiated power) given with  $P_t G_t$  product are limited by authorities, see table 1. When we look at equation (1), only parameters we can adjust in the wireless link are  $G_t$  tag antenna gain and  $L$  path loss.  $G_t$  tag antenna gain is traded with antenna size, getting bigger with decreasing frequency restricting RFID label size and path loss

increases with frequency. Therefore, for a given size of receive antenna, the environment that RFID tag operated affects your choice of wireless link frequency for maximum power transfer. For operating frequency band, 868 MHz or 915 MHz depending upon countries are employed mostly.

Table 1. Half wavelength dipole antenna sizes and allowed maximum output power for RFID applications for different frequency bands [9]

Hw. Dipole	868 MHz EU	902-928 MHz N. A. and J.	2.45 GHz for EU
EIRP= 1.64ERP	500 mW ERP, 0.5-2W with power control	4W EIRP	500 mW EIRP, 0.5-4 W indoor with power control
Antenna size	17.3 cm	12.4 cm	6.1 cm
Antenna gain	1.64	1.64	1.64

Power obtained on RFID antenna must be utilized effectively in circuits because very low amount of power reaches RFID tag in obstructed and noisy environment. Induced voltage on an antenna is rectified or multiplied to supply the power to demodulator, backscatter modulator and digital part with peripherals on passive RFID, see figure 2. Voltage multiplier or rectifier power conversation efficiency (PCE)  $\eta$  also put constraints on the range because substrate couplings, parasitics, threshold voltage drop and reverse leakage current of diodes reduces efficiency. Self-synchronous and differential rectifier is proposed to effectively remove these effects at critical communication distance [10], [11] and [12], see figure 3. The best result is achieved in [11] with %66 PCE.

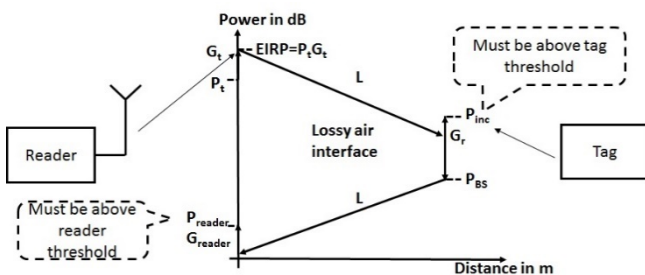

Figure 2. Passive RFID with subcircuits and monostatic and bistatic zero-IF reader

In subsequent stages of rectifier or multiplier, RFID digital core dissipates the most amount of power at one time restricting tag distance because activity of

demodulator, backscatter modulator and standard functionalities on digital core are distributed over time. By using ultra low power design techniques, a RFID processor at 0.33 V supply voltage and 1 MHz input clock with 80 nW power consumption has been designed [13].

In addition to that, when the induced power changes on the RFID antenna, non-linear effects manifest themselves and change RFID input impedance. Therefore, to have long communication distance, RFID input impedance must be matched to antenna impedance at critical communication distance in which RFID just obtains the power to run [10], called threshold.

Using the latest results in the literature %66 PCE and 80nW RFID processor  $P_{tag}$ , equal to 242.5 nW incident power on the antenna, for the range equation given in (4) for free space, it is found that range is less than or equal to 64.8 m at 868 MHz for half wavelength dipole tag antenna of gain 1.64 and 500 mW ERP in perfect matching conditions assumed. If power is increased to 2W ERP, distance becomes 129.7 m.

$$d \leq \frac{\lambda}{4\pi} \sqrt{\frac{P_{EIRP} G_r}{P_{inc}}} = \sqrt{\frac{P_{EIRP} G_r}{\frac{2P_{tag}}{\eta}}}$$

(4)

On the other hand, downlink communication is restricted by the backscattered power in either one state during reflection. When it is assumed that in perfect matching condition half of incident power is reflected in ASK backscatter modulation, 121.3 nW power are reflected during high impedance states. -102 dBm power is obtained on reader antenna for half wavelength dipole antenna with 1.64 gain ( $G_t$  reader receive antenna gain), using equation (5). If power is increased to 2W ERP, -108.5 dBm power is obtained on reader  $P_{RX}$ .

$$P_{reader} = P_{RX} = \frac{P_{ref} G_r G_t}{\left(\frac{4\pi d}{\lambda}\right)^2}$$

(5)

-108.5 dBm signal is around the thermal noise level and falls below reader threshold for monostatic configuration around -80 dBm. Therefore, bi-static configuration, separate TX and RX antenna, with high antenna gain, narrow band filter and low noise feature must be employed to overcome noise floor limitation (SNR) [4], shown in figure2. For the amount of power more than 2W ERP, distant tag can

be energized but downlink signal would be masked by thermal noise in this case. The same result for  $P_{RX}$  signal level can be found by log distance path loss model with reduced distance.

### 3. REFLECTION COEFFICIENT AND POWER EQUATIONS ON AN RFID FRONT-END MODEL

In figure 3, passive RFID front-end model is shown and power induced on antenna, antenna impedance and RFID chip input impedance are represented by a power source with  $V_0$  open circuit voltage,  $Z_{ant}$  and  $Z_{load}$  respectively. RFID input impedance is capacitive due to parasitic capacitances of transistors in rectifier circuit set by semiconductor technology in use and When the induced power changes on the RFID antenna, non-linear effects manifest themselves changing RFID input impedance. That is why a matched inductive antenna to RFID input impedance is employed at tag threshold. 1 and 2 indices for  $Z_{load}$  is used to show different states of input impedance during backscatter modulation.

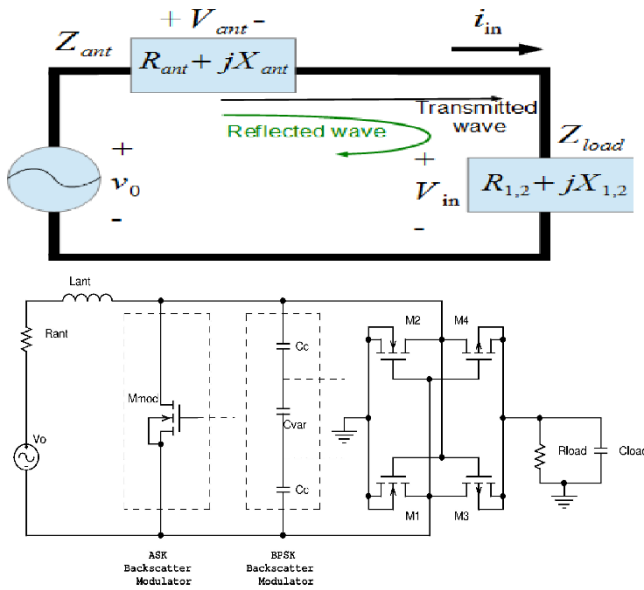

Figure 3. Passive RFID antenna model, rectifier and load @868 MHz

$$Z_{ant} = R_{ant} + jX_{ant}; Z_{load} = R_{1,2} + jX_{1,2}$$

$$\hat{v}_{in} = \frac{v_0(R_{1,2} + jX_{1,2})}{R_{1,2} + R_{ant} + j(X_{1,2} + X_{ant})}$$

$$\hat{i}_{in} = \frac{v_0}{R_{1,2} + R_{ant} + j(X_{1,2} + X_{ant})}$$

$$\rho = \frac{Z_{1,2} - Z_{ant}}{Z_{1,2} + Z_{ant}}$$

$$|\rho_{1,2}| = \sqrt{\frac{(R_{1,2} - R_{ant})^2 + (X_{1,2} + X_{ant})^2}{(R_{1,2} + R_{ant})^2 + (X_{1,2} + X_{ant})^2}}$$

$$\tau_{1,2} = 1 - |\rho_{1,2}|^2 = \frac{4R_{1,2}R_{ant}}{(R_{1,2} + R_{ant})^2 + (X_{1,2} + X_{ant})^2}$$

$$P_{aval} = \frac{P_{inc}}{2} = \frac{v_0^2}{8R_{ant}}$$

$$\begin{aligned} P_{RFIn1,2} &= \frac{1}{2} R(\hat{v}_{in}^* \hat{i}_{in}) \\ &= \frac{1}{2} R \left( \frac{v_0^2 (R_{1,2} - jX_{1,2})}{|R_{1,2} + R_{ant} + j(X_{1,2} + X_{ant})|^2} \right) \\ &= \frac{1}{2} \left( \frac{v_0^2 R_{1,2}}{(R_{1,2} + R_{ant})^2 + (X_{1,2} + X_{ant})^2} \right) \\ &= \frac{v_0^2}{8R_{ant}} \left( \frac{4R_{1,2}R_{ant}}{(R_{1,2} + R_{ant})^2 + (X_{1,2} + X_{ant})^2} \right) \\ &= P_{aval} \left( 1 - \left| \frac{Z_{1,2} - Z_{ant}^*}{Z_{1,2} + Z_{ant}} \right|^2 \right) = P_{aval} (1 - |\rho_{1,2}|^2) \end{aligned}$$

$$P_{RFIn1,2} = P_{aval} \cdot (1 - |\rho_{1,2}|^2) = P_{aval} \cdot \tau_{1,2} \quad (6)$$

$\hat{v}_{in}$ : Peak input voltage

$\hat{i}_{in}$ : Peak input current

$v_0$ : Source peak voltage

$R_{1,2}$ : State 1 and 2 resistance

$X_{1,2}$ : State 1 and 2 reactance

$R_{ant}$ : Antenna radiation resistance

$X_{ant}$ : Antenna radiation reactance

$\rho_{1,2}$ : State 1 and 2 reflection coefficient

$\tau_{1,2}$ : State 1 and 2 transmission coefficient

$P_{aval}$ : Incident power

$P_{RFIn1,2}$ : State 1 and 2 transmitted power to RFID

$P_{aval} |\rho_{1,2}|^2$ : Reflected power

Transmitted power to RFID from incoming RF field before backscatter modulation is given in (5) [7]. As we remember from transmission line theory, impedance matching, equal to zero reflection coefficient, is required to achieve maximum power transfer. In our case, conjugate match load ( $Z_{ant} = Z_{load}^*$ ) corresponds to zero reflection coefficient and half of the power induced on antenna is transferred to load ( $P_{inc}/2$ ).

#### 4. BACKSCATTER MODULATION POWER EQUATIONS

There are two common backscatter modulations ASK and BPSK to be considered. On the reader side, average difference power radiated from antenna resistance between two states given in (8) is considered for data and the absolute power given in (7) must be above reader threshold at least one of two state. During backscatter communication in state 1 and 2, power transmitted to or obtained by tag is given in (9). (8) restricts communication range.

$$P_{BSdif} = \frac{|p_2 i_2 - p_1 i_1|^2}{2} R_{ant}$$

$$i_{1,2} = \frac{v_0}{Z_{ant} + Z_{1,2}} = \frac{v_0}{2R_{ant}} (1 - \rho_{1,2})$$

$$P_{DIS1,2} = \frac{1}{2} R(\hat{v}_{ant}^* \hat{i}_{in}) = \frac{1}{2} \left( \frac{v_0^2 R_{ant}}{(R_{1,2} + R_{ant})^2 + (X_{1,2} + X_{ant})^2} \right) = P_{aval} \left( \frac{\tau_{1,2} R_{ant}}{R_{1,2}} \right) \quad (7)$$

$$P_{BSdif} = P_{aval} |p_2(1 - \rho_2) - p_1(1 - \rho_1)|^2 \quad (8)$$

$$P_{RFinavg} = P_{aval} (p_1(1 - |\rho_1|^2) + p_2(1 - |\rho_2|^2)) \quad (9)$$

$P_{DIS1,2}$ : State 1 and 2 dissipated power on antenna

$P_{BSdif}$ : Average dissipated power on antenna between state 1 and 2

$P_{RFinavg}$ : Average input power

$p_{1,2}$ : Duty cycle for state 1 and 2,

$$0 < p_{1,2} < 1 \text{ and } p_1 + p_2 = 1$$

Matched load, open circuit and short circuit for ASK backscatter is easily grasped on the model in figure 3. For BPSK backscatter, real part of reflection coefficient is zero and imaginary part equal in amount but opposite in sign,  $\pm m$ . Modulation is achieved by changing RFID input capacitance equal amount and

so changing phase of voltage signal on antenna radiation resistance in equal degree. Base band signal from tag to reader is proportional to this phase signal  $\phi$  which must be detectable on the reader side. Resistance and reactance values of RFID input impedance for BPSK equal amount of mismatched condition are found below.

$$\rho_{1,2} = \pm jm \quad 0 < m < 1 \quad (10)$$

$$\phi_{1,2} = \tan^{-1}(\pm m) \text{ Voltage phase over } R_{ant} \quad (11)$$

$$Z_{1,2} = Z_{ant} + \frac{2R_{ant}}{1 - \rho_{1,2}} = -jX_{ant} + \frac{1 + \rho_{1,2}}{1 - \rho_{1,2}} R_{ant} \quad (12)$$

$$X_{1,2} = -X_{ant} \pm \frac{2mR_{ant}}{1 + m^2} \quad (13)$$

$$R_{1,2} = \frac{(1 - m^2)}{(1 + m^2)} R_{ant} \quad (14)$$

In table 2, induced RFID chip and backscatter power equations for different modulations are presented. RFID-A and RFID-B can be run from longer distance than RFID-C increasing duty cycle up to 0.9 or 0.95 because RFID input power and average difference backscatter power have increasing trends in ASK backscatter in contrast to conflicting trends in BPSK modulation. OC case in RFID-A brings more average difference backscatter power on the reader side than SC case in RFID-B, as shown in [1]. However, in standards such as EPC Class1 Gen2 (GS1), each symbol has equal amount of time for high or low state, forcing %50 duty cycle and state duration for ASK and BPSK backscatter modulation types. In practice it is hard to create OC case. Actually, there is always reflection due to finite mismatches.

Table 2. Backscatter modulation comparisons [6]

	RFID-A	RFID-B	RFID-C
<b>Type of Modulation</b>	<b>ASK backscatter</b>	<b>ASK backscatter</b>	<b>BPSK backscatter</b>
State 1	$\rho_1 = 0$ $p_1 = DC$ Matched load	$\rho_1 = 0$ $p_1 = DC$ Matched load	$\rho_1 = -jm$ $p_1 = 0.5$ Equal mismatch
State 2	$\rho_2 = 1$ $p_2 = 1 - DC$ Open circuit (OC)	$\rho_2 = -1$ $p_2 = 1 - DC$ Short circuit (SC)	$\rho_2 = jm$ $p_2 = 0.5$ Equal mismatch
Average difference backscatter power	$P_{BSdif} = DC^2 P_{aval}$	$P_{BSdif} = (3DC - 2)^2 P_{aval}$	$P_{BSdif} = m^2 P_{aval}$
Average input power	$P_{RFInavg} = DC P_{aval}$	$P_{RFInavg} = DC P_{aval}$	$P_{RFInavg} = 1 - m^2 P_{aval}$
State 1 backscatter power	$P_{aval}$	$P_{aval}$	$P_{BS1} = P_{aval}(1 + m^2)$
State 2 backscatter power	0	$P_{BS1} = P_{aval} \left( \frac{4R_{ant}^2}{R_{ant}^2 + X_{ant}^2} \right)$	$P_{BS1,2} = P_{aval}(1 + m^2)$

### 5. REALIABILITY OF BPSK AND ASK MODULATIONS AND MINIMUM SNR

Minimum signal to noise ratio for a targeted BER is required to be known for reader sensitivity. Signal from tag to reader passes through multipath environment getting attenuated by reflected signals from near-by objects, called multipath fading for small amplitudes and shadowing for large amplitudes. In addition to that, channel noise must be considered to see effects of real environment challenges. On signal side, backscattered difference power is relevant for reader, given in equation (8).

To see effect of scattered signals and noise on the signal power, proper channel models are employed depending upon application environment. Weak ASK and BPSK backscatter modulated signals are assumed to pass through AWGN channel (Additive White Gaussian Noise), Rayleigh fading channel, useful model when there is no line of sight or there are many reflectors, and Rician fading channels to see their performances, used when the line of sight component

is much stronger than others figure 4. Bit error probability is given in (15), (16) and (17) for AWGN, Rayleigh and Rician channel models,  $E_b$  energy per bit and  $N_0$  noise. When you think about situation that the same place located tags with BPSK modulation index 0.5, 0.41 change in reactance is equal to resistance, 0.32 and ASK %50 duty cycle has -3 dB, -4.7 dB, -7 dB and -3 dB lower SNR ratio with respect to a tag BPSK modulation index 0.707 figure 4. They are compared to exhibit SNR and BER performances considering differences by [simulations in theory and 10 million normal distributed samples](#) in figure 4 [14].  $k$  is ratio of dominant LOS component power to scattered components power in Rician channel model.

$$P_b = \frac{1}{2} \operatorname{erfc} \left( \sqrt{\frac{E_b}{N_0}} \right) \tag{15}$$

$$P_b = \frac{1}{2} \left( 1 - \sqrt{\frac{\frac{E_b}{N_0}}{\frac{E_b}{N_0} + 1}} \right) \tag{16}$$

$$P_b = \frac{1}{2} \operatorname{erfc} \left( \sqrt{\frac{k \frac{E_b}{N_0}}{k + \frac{E_b}{N_0}}} \right) \tag{17}$$

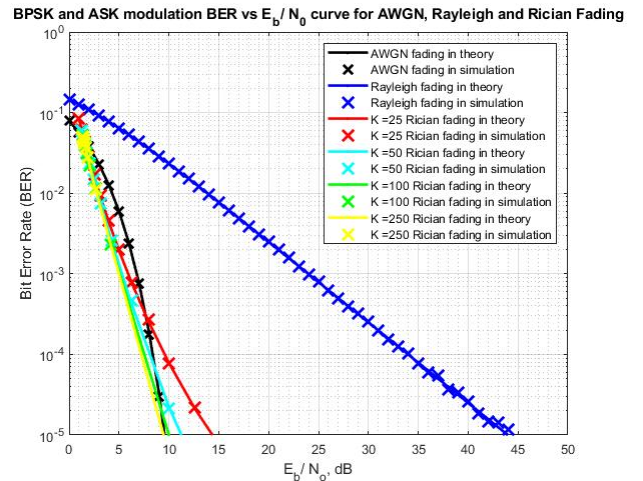

Figure 4. ASK and BPSK backscatter modulation BER curve for AWGN, Rayleigh and Rician channel models

BER value for BPSK  $m=0.707$  tag is always lower than other ASK and BPSK tags and %50 ASK and BPSK  $m=0.5$  are the same although input power to tag in BPSK tag is %50 higher than ASK tag. Effect of noise for low modulation indexes is higher since

signal power is low. There is always needed much higher signal to noise ratio in multiple reflector environment.

Practical value of  $10^{-4}$  and  $10^{-5}$  BER are used general. For example,  $10^{-4}$  and  $10^{-5}$  BER result in 0.05 and 0.005 read error rate for 64 byte EPC (Electronic Product Code) and similarly, 0.01 and 0.001 for 12 byte EPC. For  $10^{-5}$  BER value, minimum SNR levels are around 9.5 dB, 11 dB and 44 dB corresponding to AWGN, Rician for  $k=25$  and Rayleigh fading channels.

## 6. MAXIMUM RANGE

During backscatter modulation, tag can be run out of energy due to low state of symbol. For ASK case, there are two situations limiting the uplink distance. First, it is considered that tag has enough energy on the capacitor  $C_{load}$  during low level of symbol with short duration for fast enough communication not to run out of energy as in sensor tags, see figure 3. In this case, we are limited with equation (18). On the other hand, equation (19) limits uplink distance for tags with small  $C_{load}$  and low state of symbol with long duration for low speed communications. For BPSK case, equation (4) can be rewritten as in (20). Equations are given for %50 state durations.

$$r \leq \frac{\lambda}{4\pi} \sqrt{\frac{P_{EIRP}G_r}{P_{inc}}} = \frac{\lambda}{4\pi} \sqrt{\frac{P_{EIRP}G_r\eta(1-|\rho_1|^2)}{2P_{tag}}} \quad (18)$$

$$r \leq \frac{\lambda}{4\pi} \sqrt{\frac{P_{EIRP}G_r}{P_{inc}}} = \frac{\lambda}{4\pi} \sqrt{\frac{P_{EIRP}G_r\eta((1-|\rho_1|^2)+(1-|\rho_2|^2))}{4P_{tag}}} \quad (19)$$

$$r \leq \frac{\lambda}{4\pi} \sqrt{\frac{P_{EIRP}G_r}{P_{inc}}} = \frac{\lambda}{4\pi} \sqrt{\frac{P_{EIRP}G_r\eta(1-m^2)}{2P_{tag}}} \quad (20)$$

For downlink communication, working distance can be rewritten for ASK and BPSK modulations in similar case to above (21), (22) and (23) assuming that tag obtains only enough power to run,  $G_r$  reader receive antenna gain. For ASK and BPSK modulations, backscatter difference power and so  $P_{BS1,2}$  for either one of states must be above reader receive threshold,  $P_{reader\_th}$  represents this level. Reader sensitivity can be found by  $P_{reader\_th} = -174 \text{ dBm/Hz} + \text{NF} + 10\log(\text{BW}) + \text{SNR}_{\min}$ , NF noise figure of system, BW bandwidth and  $\text{SNR}_{\min}$  minimum signal to noise ratio of the system, sum of channel

SNR, RF chain SNR and analog baseband SNR. First three terms represents integrated noise of system called noise floor.

$$d \leq \frac{\lambda}{4\pi} \sqrt{\frac{P_{BSdif}G_rG_t}{P_{reader\_th}}}$$

$$d \leq \frac{\lambda}{4\pi} \sqrt{\frac{0.25 P_{tag}G_rG_t}{\eta P_{reader\_th}(1-|\rho_1|^2)}} \quad (21)$$

$$d \leq \frac{\lambda}{4\pi} \sqrt{\frac{0.5 P_{tag}G_rG_t}{\eta P_{reader\_th}((1-|\rho_1|^2)+(1-|\rho_2|^2))}} \quad (22)$$

$$d \leq \frac{\lambda}{4\pi} \sqrt{\frac{P_{tag}m^2G_rG_t}{\eta P_{reader\_th}(1-m^2)}} \quad (23)$$

As stated before maximum communication distance is restricted by either uplink or downlink communication, found by  $\min(r,d)$  for two modulations. Using the latest results in the literature %66 PCE  $\eta$ , 80nW RFID processor  $P_{tag}$ , half wavelength dipole tag antenna gain 1.64 for given size, reader receive antenna gain 6.56 (8.14 dB), 2 W ERP, 0 state 1 reflection coefficient  $\rho_1$ , -1 state 2 reflection coefficient  $\rho_2$  and -101 dBm reader threshold  $P_{reader\_th}$  with GS1 640 kHz, 5.5 dB noise figure and 9.5 dB more than thermal noise at 868 MHz in perfect matching conditions assumed, results are listed in table 3.



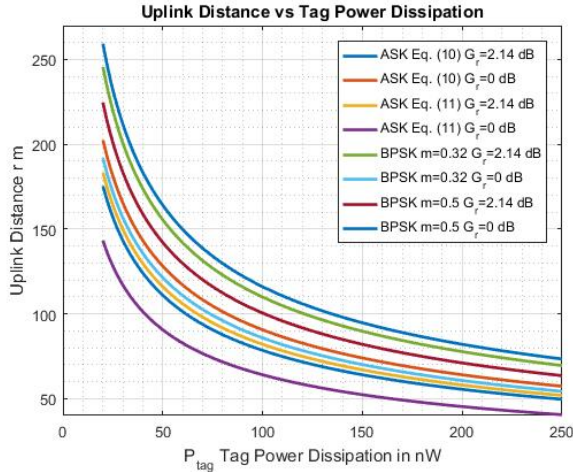

Figure 5. Uplink distance for ASK and BPSK modulations for given parameters

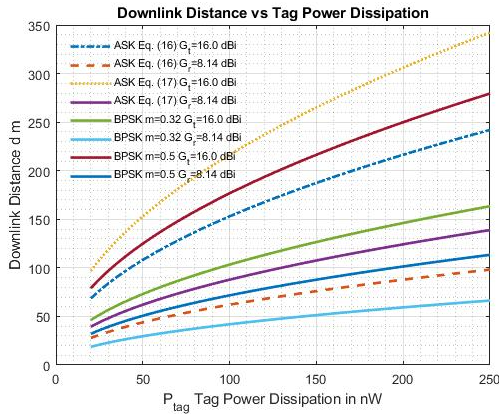

Figure 6. Downlink distance for ASK and BPSK Modulation for given parameters

During design time, rectifier efficiency  $\eta$ , tag power dissipation  $P_{tag}$ , tag antenna gain  $G_r$  for a given RFID tag label size, reader threshold  $P_{reader\_th}$  and transmit power  $P_{ERP}$  limited by authorities are known and for given parameters above, only, reader receive antenna gain  $G_t$  and  $m$  modulation index for ASK and BPSK modulations can be changed. This point can be utilized to find antenna gain  $G_t$  and  $m$  modulation index to make  $d$  equal to  $r$ , given in (24), (25) and (26). If system is uplink limited, the distance difference brings more signal power on reader side so more SNR and reliable operation. When downlink limits distance, equations (24), (25) and (26) must be considered. We face this situation now and in further improvement of  $P_{tag}$  and  $\eta$  and higher  $P_{reader\_th}$  requirement. The same results can be found by log distance path loss model.

$$G_t = \frac{P_{ERP} P_{reader\_th} \eta^2 (1 - |\rho_1|^2)^2}{0.5 P_{tag}^2} \quad (24)$$

$$G_t = \frac{P_{ERP} P_{reader\_th} \eta^2 ((1 - |\rho_1|^2) + (1 - |\rho_2|^2))^2}{2 P_{tag}^2} \quad (25)$$

$$A = P_{reader\_th} P_{ERP} \eta^2 B = 2 P_{tag}^2 G_t$$

$$m = \sqrt{\frac{+2A + B \pm \sqrt{4AB + B^2}}{2A}} \quad (26)$$

Table 3. Maximum free space range for  $\eta=0.66$ ,  $P_{tag}=80nW$ ,  $G_r=1.64$ ,  $G_t=6.56$ ,  $P_{reader\_th}=-101$  dBm,  $P_{ERP}=2W$  @868MHz

Modulation	Uplink Distance	Downlink Distance	Maximum Range
ASK %50 SC and matched load	129.7 m for Eq. (18)	55.6 m for Eq. (21)	55.6 m
	91.7 m for Eq. (19)	78.6 m for Eq. (22)	78.6 m
BPSK $m=\pm 0.707$ ( $\varphi=\pm 35.3^\circ$ )	91.7 m	111.2 m	91.71 m
BPSK $r$ and $d$ equal $m=\pm 0.66$ ( $\varphi=\pm 33.4^\circ$ )	97.5 m	97.7 m	97.5 m
BPSK $m=\pm 0.5$ ( $\varphi=\pm 26.6^\circ$ )	112.3 m	64.2 m	64.2 m
BPSK $m=\pm 0.41$ ( $\varphi=\pm 22.3^\circ$ )	118.2 m	50.1 m	50.1 m
BPSK $m=\pm 0.32$ ( $\varphi=\pm 17.8^\circ$ )	122.9 m	37.0 m	37.0 m
BPSK $m=\pm 0.22$ ( $\varphi=\pm 12.4^\circ$ )	126.5 m	25.4 m	25.4 m

After RFID tag design, changes can be made on  $G_t$  reader receive antenna gain and reader threshold  $P_{reader\_th}$  (actually there is no change) to make two distances equal. If modulation index  $m$  is bigger than  $m=0.66$ , tag is limited by uplink distance. Modulation index value close to 1 cannot be used because tag cannot be energized (20). Low gain  $G_t$  antenna can be used for cost reduction or  $P_{reader\_th}$  reader threshold requirement can be relaxed to higher values with low BER values while keeping the modulation index and so uplink distance the same (23). Actually, uplink limited system has more reliable operation. In ASK case, there is similar situation. On the other hand,

below  $m=0.66$  value, signal will not be fetched for the distances more than maximum downlink distance. Higher gain receive antenna can bring additional degree of freedom to increase downlink distance as much as possible or similarly  $P_{\text{reader\_th}}$  reader threshold level can be reduced for this purpose at the cost of more BER while keeping the modulation index  $m$  and so uplink distance the same. However, it is needed to be considered that baseband signals with low modulation index  $m$  is hard to detect on reader side and effect of noise increases. That is why for the environment being operated the lowest level modulation index  $m$  must be decided first. Then, antenna gain  $G_t$  and  $P_{\text{reader\_th}}$  can be adjusted to make two distances equal, a kind of trade-off (20) and (23). Further reduction of  $P_{\text{tag}}$  and improvement of  $\eta$  has also bright future in terms of increasing distance, modulation index  $m$  and so increasing SNR on reader (23). In ASK case, situations are similar. In addition, if downlink limited distance, antenna gain could be increased to 35.7 (15.5 dBi) and 8.8 (9.5 dBi) to make two distances equal (24) and (25).

## 7. RESULTS

In this study, uplink and downlink distances are shown for UHF RFID in detail and parameters to make two distance equal are given. Also, it is shown that reflected signal levels require separate TX and RX antenna, bistatic configuration. Latest works show that BPSK tags are proper choice for working distance and reliability.

Complete link budget in a RFID system is given for different environments. Power consuming parts effecting this range in a passive RFID hardware are presented with power reduction techniques to have longer range because distant operation is desired in harsh and noisy working environments. It is shown on the range equations by using the results from literature that both uplink and downlink communication distance must be considered during the design. Hence, in the future we will see next generation RFID tags and readers working from longer range in challenging environments due to low power nature of RFID tags, especially in supply chain management and mid-range passive wireless sensor network (WSN) environment and lower detection threshold of readers.

Parasitics included simulations in TSMC 0.18  $\mu\text{m}$  RF technology show that differential rectifier efficiency

in figure 3 is around %66-68 over wide range of input power up to more than -37 dBm with fine tunings. Latest works on RFID tag processor achieved 80 nW in similar technology node [13]. With these points and reasonable parameters given in table 3, two state difference electromagnetic power reaching RFID reader is around integrated or thermal noise of systems. This result directs to separate TX and RX antenna bistatic configuration for RFID reader.

ASK tag with large capacitor at the rectifier output and matched load have longer uplink distance than other ASK tags and BPSK tags when you look at equations (18), (19), (20) and table 3. On the other hand, Downlink limits due to noise floor of reader. For this purpose, high gain reader receive antenna must be employed to increase range considering cost containment. Similarly, higher modulation index BPSK modulation has higher downlink distance.

In the presence of current improvements, BPSK tags are proper choice in noisy environments and have higher working distance. High modulation index BPSK modulation has more reliable operation with low BER proper to use harsh environments for safe information and to decrease error. None the less, situation reverse to ASK in terms of working distance and reliability if high antenna gain  $G_t$  around 16 dBi is used. The same results and conclusions can be found by log distance path loss model except running distance.

Simulations on different communication channel models show that noise requires wide range of modulation index tags depending upon operating environment. One tag with programmable mismatch in BPSK case like capacitor banks looks more logical.

Some other opportunities are seen. First, when you look at equation (8) and (9), there is a potential to use available power in BPSK modulation for higher speed and bandwidth efficient M-ary modulation formats such as QAM. In table 3, the same situation is seen by looking at decreasing angle  $\arctan(\pm m)$  and decreasing magnitude (or distance)  $(1+m^2)P_{\text{aval}}$  going down to table. Realization can be done employing more number of varactors on BPSK modulator over positive x-plane at cost of the distance penalization. Advantage of M-ary modulation formats is reduction of the amount of processing time on massive deployments. Second, for portable devices, operation distance is defined and less than maximum distance, low cost reader hardware with small power amplifier

and fast operation can be used to dissipate less energy, to have long battery duration, to have less air traffic and to create less electromagnetic interference.

### REFERENCES

- [1] P. Nikitin and K. V. S. Rao, "Theory and measurement of backscattering from RFID tags," *IEEE Antennas Propag. Mag.*, vol. 48, no. 6, pp. 212–218, Dec. 2006.
- [2] S. S. Srikant and R. P. Mahapatra, "Read Range of UHF Passive RFID," *Int. J. Comput. Theory Eng.*, vol. 2, no. 3, pp. 323–325, 2010.
- [3] Y. Gao, Z. Zhang, H. Lu, and H. Wang, "Analysis and calculation of read distance in passive backscatter RFID systems," *LISS 2012 - Proc. 2nd Int. Conf. Logist. Informatics Serv. Sci.*, vol. 2, no. 1, pp. 905–912, 2013.
- [4] J. D. Griffin and G. D. Durgin, "Complete Link Budgets for Backscatter-Radio and RFID Systems," *IEEE Antennas Propag. Mag.*, vol. 51, no. 2, pp. 11–25, Apr. 2009.
- [5] P. Nikitin, K. V. S. Rao, S. Lam, and W. Ave, "UHF RFID TAG CHARACTERIZATION : OVERVIEW AND STATE-OF-THE-ART," no. 2, pp. 2–7.
- [6] F. a. Hussien, D. Z. Turker, R. Srinivasan, M. S. Mobarak, F. P. Cortes, and E. Sanchez-Sinencio, "Design considerations and tradeoffs for passive RFID tags," vol. 5837, pp. 559–570, Jun. 2005.
- [7] U. Karthaus and M. Fischer, "Fully Integrated Passive UHF RFID Transponder IC With 16 . 7- W Minimum RF Input Power," vol. 38, no. 10, pp. 1602–1608, 2003.
- [8] M. Viswanathan and S. Edition, "SIMULATION OF DIGITAL COMMUNICATION SYSTEMS USING MATLAB."
- [9] P. Note, "ERC Recommendation 70-03," no. February, 2014.
- [10] M. H. Ouda *et al.*, "for Implantable Intraocular Pressure Monitoring," pp. 1–8.
- [11] K. Kotani, A. Sasaki, T. Ito, and S. Member, "High-Efficiency Differential-Drive CMOS Rectifier," vol. 44, no. 11, pp. 3011–3018, 2009.
- [12] R. Vaddi, R. P. Agarwal, S. Dasgupta, and T. T. Kim, "Design and Analysis of Double-Gate MOSFETs for Ultra-Low Power Radio Frequency Identification (RFID): Device and Circuit Co-Design," *J. Low Power Electron. Appl.*, vol. 1, no. 3, pp. 277–302, Jul. 2011.
- [13] W. Shi, C. S. Choy, J. Guo, C. F. Chan, K. N. Leung, and K. P. Pun, "A 90nm RFID tag's baseband processor with novel PIE decoder and uplink clock generator," *Midwest Symp. Circuits Syst.*, pp. 644–647, 2010.
- [14] DSPLOG, "Communication Channels." [Online]. Available: <http://www.dsplog.com>.