A NOVEL MULTI-HOP WIRELESS NETWORK PROPOSAL TO CONTROL ELEVATOR FLOOR FIXTURES IN LOW-RISE AND MEDIUM-RISE BUILDINGS

*Muhammed Macit LAJİN**
*Sait Eser KARLIK***

Received: 01.03.2019 ; revised: 04.04.2019 ; accepted: 05.04.2019

Abstract: Wired communication systems used to control elevator floor fixtures have problems due to huge amount of cables used in implementation, long installation time, long troubleshooting time and chronic faults. This paper proposes a double-jump multi-hop wireless network for low-rise and medium-rise buildings to control elevator floor fixtures using wireless short packet protocol (WSP). Telegram success rate, telegram intensity, hop time and signal power measurements have been performed on the proposed network. Experimental results emphasize that telegram intensity of about 75 telegram/s guarantees 100 % telegram success rate. Average hop times of 16.1 ms and 17.5 ms for the first and second hops have been measured respectively and found to be enough for low-rise and medium-rise buildings. Signal power measurements show that proposed network may be capable of performing even triple jumps or more instead of double jumps contributing to the speed, telegram intensity and the performance of the network.

Keywords: Multi-hop wireless network, WSP protocol, Data communication, Elevator

Alçak ve Orta Yükseklikteki Binalarda Asansör Kat Ünitelerinin Kontrolü İçin Yeni Bir Çok Atlamalı Kablosuz Ağ Önerisi

Öz: Asansör kat ünitelerini kontrol eden kablolu haberleşme sistemlerinde, yüksek miktarlarda kablo kullanımı, kurulum ve onarım sürelerinin uzun olması, kronik arızalar gibi sorunlarla karşılaşılmaktadır. Bu makalede, kablosuz kısa paket protokolü (WSP) kullanarak alçak ve orta yükseklikteki binalarda kat ünitelerini kontrol edebilecek çift sıçramalı çok atlamalı kablosuz bir ağ önerilmektedir. Önerilen ağ üzerinde, telegram başarımlı oranı, telegram yoğunluğu, atlama süresi ve işaret gücü ölçümleri gerçekleştirilmiştir. Deneysel sonuçlar, yaklaşık 75 telegram/s'lik telegram yoğunluğunun %100 telegram başarımlı oranını garanti ettiğini vurgulamaktadır. Önerilen ağda, birinci ve ikinci atlama için, sırasıyla, 16,1 ms ve 17,5 ms ortalama atlama süreleri ölçülmüş olup bu sürelerin alçak ve orta yükseklikteki binalar için yeterli olduğu bulunmuştur. İşaret gücü ölçümleri, önerilen ağın, iki sıçramalı yerine üç ya da daha fazla sıçramalı kullanımının mümkün olabileceğini göstermektedir. Bu durum, ağın hızına, telegram yoğunluğuna ve performansına katkıda bulunacaktır.

Anahtar Kelimeler: Çok atlamalı kablosuz ağ, WSP protokolü, Veri iletişimi, Asansör

* Bursa Uludağ University, Graduate School of Natural & Applied Sciences, Electronics Engineering MSc. Program, 16059, Görükle, Bursa, Turkey

** Bursa Uludağ University, Faculty of Engineering, Department of Electrical and Electronics Engineering, 16059, Görükle, Bursa, Turkey

1. INTRODUCTION

Usage of wireless multi-hop networks has recently increased in many different areas such as traffic (Ansari, 2009), military (Đurišić et. al., 2012), medicine (Furtado and Trobec, 2011), agriculture (Wark et. al., 2007) and environmental monitoring (Shibata et. al., 2009).

In elevator industry, despite the reliability and speed of wire-based solutions, there are many complaints about such systems regarding long installation time and troubleshooting difficulties. There are many problems that have been witnessed related to using cables inside the elevator hoistway. Cables can cause short-circuits, tangle to cabin and be plucked, and deteriorate because of humidity, water and temperature as time goes by, leaving the elevator vulnerable due to hidden hard-to-find faults resulting from installation errors or lack of worker experience (Venables, 2017). Some patents have been published regarding this problem in an attempt to find a wireless solution (Crenella et. al., 2003; Oh and Hootsmans, 2012; Motoyama, et. al., 2002). In Crenella et. al. (2003), a two-part wireless network has been proposed for group elevators. A low-power wireless network connects all fixtures on one floor and then a high-power wireless network that uses 2.4 GHz frequency connects each floor to the appropriate control panel in a form of point-to-point connection. The high-power wireless network could affect other devices in the building working in the same frequency band. On the other hand, for the high-power wireless network, Yagi antenna has been suggested to be mounted on the top of the hoistway and two other antennas to be mounted on the top and bottom of the cabin to convey high-power wireless signals back and forth between both sides of the cabin. This setup adds complexity to the system, requires experienced workers and lacks flexibility. Oh and Hootsmans (2012) suggests a setup that achieves a high flexibility but with no proof that the network could be able to work in medium-rise buildings. Motoyama, et. al. (2002) suggests a double-jump multi-hop network to increase the speed of the network but there is again no proof that this network is able to work in medium-rise buildings. Furthermore, it lacks flexibility contrary to the case in Oh and Hootsmans (2012).

In this paper, in order to avoid disadvantages of Crenella et. al. (2003), Oh and Hootsmans (2012) and Motoyama et. al. (2002), a double-jump multi-hop wireless network suitable to be used in elevators for low-rise and medium-rise buildings is proposed. Wireless short packet protocol (WSP) has been used in the proposed network considering not only the reliability in application but also the opportunity in integrating elevator networks wirelessly to building management systems gathering different types of information from peripheral devices such as wireless batteryless switches mentioned in Anders (2005). In the second section WSP protocol is introduced. The third section includes the proposed double-jump multi-hop wireless network. The fourth section exhibits results of three experiments performed to evaluate the reliability and the speed of the proposed network. A preliminary introduction of a hybrid wired-wireless network that may overcome limitations of the proposed network in high-rise buildings can be found in the fifth section.

2. WSP PROTOCOL

Specifying a wireless protocol for low-power devices to keep the energy consumption extremely low, WSP protocol is basically a protocol optimized for energy harvesting architectures (ISO/IEC 14543-3-10, 2012). Due to the energy consumption constraints, data is transmitted using Sub-1 GHz frequencies with 125 kbps data rate using ASK or FSK modulation. In this protocol, two mechanisms are used to overcome signal collisions and to increase the performance of the network. The first mechanism is sending the same data three times and keeping the communication time as short as possible. In this protocol, data in the network layer is called telegram while in the data link layer it is called subtelegram. Each telegram could contain from 1 to 3 identical subtelegrams. The main reason of sending

3 identical subtelegrams is that if one or two subtelegrams have been interrupted by another signal in the same channel there is a high possibility that the third subtelegram is going to be received by the receiver. The period between subtelegrams is randomized and the length of each subtelegram is very short which helps to keep the power consumption low and to decrease the potential collision of telegrams in the air. The second mechanism is “Listen Before Talk (LBT)” technique which checks the occupancy of the wireless channel before transmitting any telegrams. LBT technique is just supported by transceivers since they should be awake all the time and therefore are powered continuously by a power supply.

3. THE DOUBLE-JUMP MULTI-HOP WIRELESS NETWORK

The proposed network is a double-jump linear multi-hop network. Sent telegrams travels with double jumps to reach the destination. Figure 1 shows an example of data transmission from the first floor to the elevator control panel, i.e. CP, in a 5-floor wireless multi-hop network topology, where a message sent from point 1 to CP is routed by points 3 and 5, respectively. Considering the case where the distance between the control panel and the last floor point is long or the case where the flooring between the machine room and the last floor has been constructed from materials that may weaken radio signals, the network has been designed to make the last floor unit engage in every message transmission scenario. Different message transmission scenarios from each individual floor unit to the control panel and vice versa are shown in Figure 2.



Figure 1:
Data transmission in wireless linear multi-hop network topology

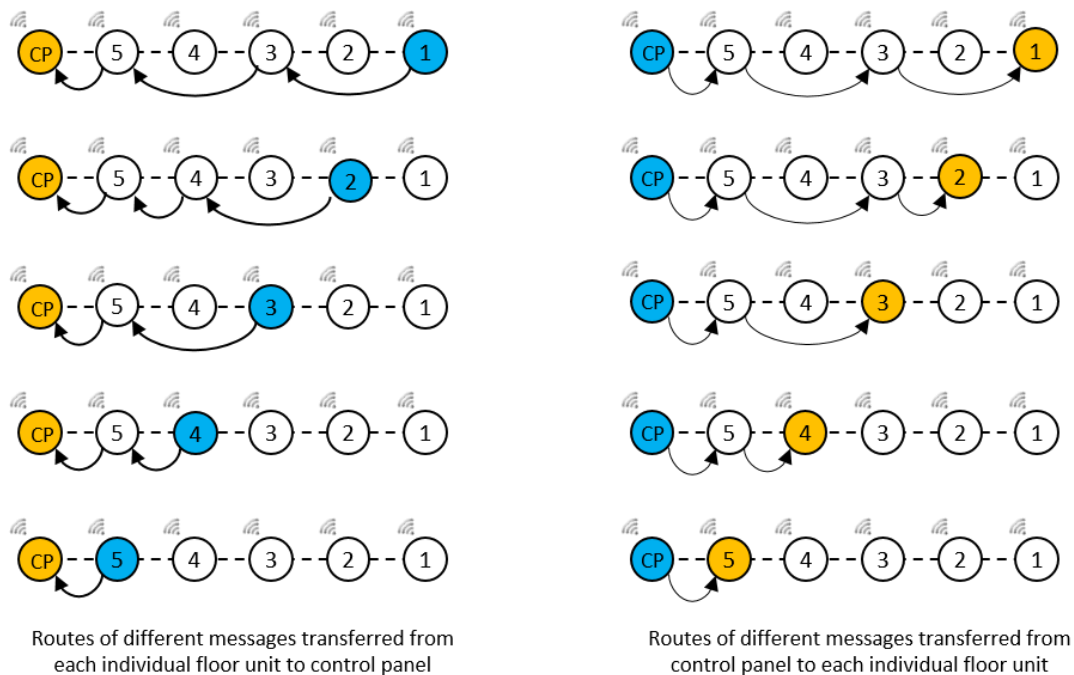

Figure 2:
Routes of messages sent in a 5-floor multi-hop linear network



Figure 3:
The route of broadcasting messages

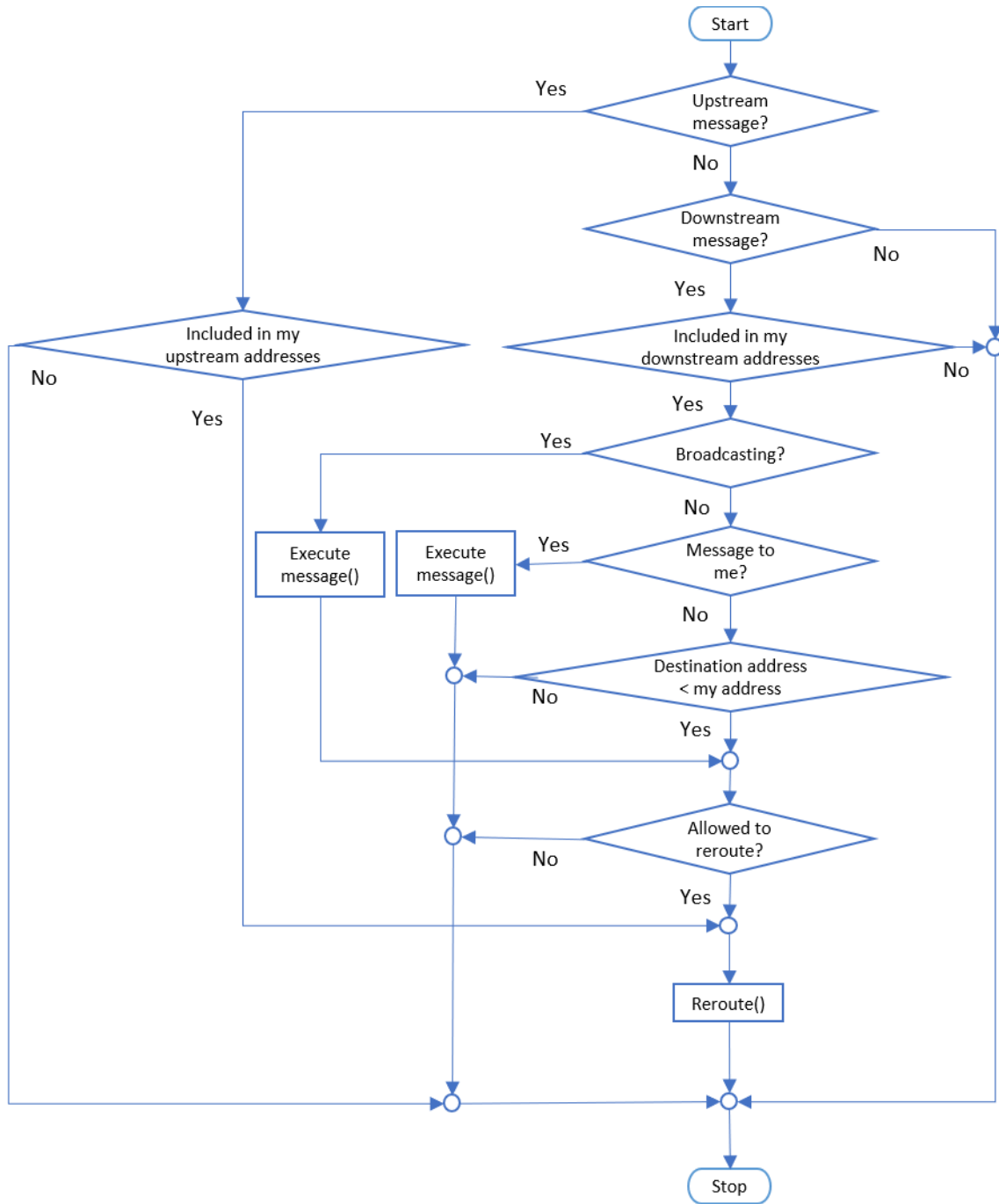

Figure 4:
The routing algorithm of the proposed multi-hop linear wireless network

Each point has an address corresponding to its own floor, and each point has its individual routing table that determines the points from which a message can be received in either upstream direction or downstream direction. Routing tables are statically allocated and they are distributed by the control panel in the network initialization process. When a point receives messages from points that are not included in its routing table, it will not accept those messages. Essentially, each routing table has lists of upstream and downstream addresses. The list of upstream addresses contains the addresses of points from which a message can be accepted in the upstream direction. The list of downstream addresses acts similarly but in the downstream direction. Each routing table determines whether the relevant point has the ability to route the broadcasting messages coming from the control panel or not, i.e. not every point participates in broadcasting. Figure 3 shows the route of broadcasting messages transmitted by CP. Figure 4 shows the routing algorithm of the proposed network.

4. EXPERIMENTS

The block scheme of the prototype floor unit designed to perform experiments is given in Figure 5. It essentially includes an ATmega328 microcontroller, a TCM320 transceiver, a 2x16 LCD and a keypad. In the transceiver, which uses the WSP protocol, the maximum transmission time of a telegram is 40 ms while the transmission of a subtelegram lasts approximately 1.2 ms. The transceiver is loaded with the Gateway Controller firmware which enables sending and receiving information between the transceiver itself and the microcontroller through UART using ESP3 protocol. The type of telegram that has been used is VLD with a total length of 13 bytes. To be able to analyze the network and read all the telegrams through computer EOP350 board and USB300 device have been used. EOP350, equipped with a TCM320 transceiver loaded with DolphinSniffer firmware, has been used in Experiment 1 and Experiment 3 to analyze the subtelegrams and measure the signal attenuation, respectively. USB300 has been used in Experiment 2 to measure the hop time of the designed multi-hop network. All telegrams have been sent to a laptop computer (Intel(R) Core(TM) i5-6200U CPU @2.30GHz 2.40GHz, OS 64-bit Windows 10) and shown using DolphinView software. For related datasheets of the prototype floor unit component and DolphinView software please refer to EnOcean GmbH, 2015a; EnOcean GmbH, 2015b; EnOcean GmbH, 2017a; EnOcean GmbH, 2017b and EnOcean GmbH, 2017c.

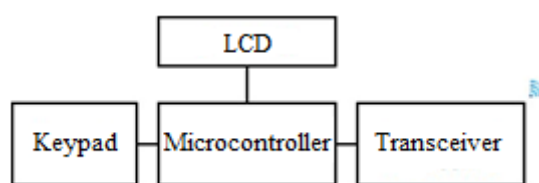

Figure 5:
Prototype floor unit used in experiments

4.1. Experiment 1: Telegram Success Rate & Telegram Intensity Measurements

Experiment 1, whose setup is shown in Figure 6, has been conducted in a laboratory to find the bottleneck point of the TCM320 transceiver. Since this experiment depends heavily on the self-performance of the transceiver module, the rerouting units shown in Figure 6 representing the floor units in a 5-floor network topology have been used instead of the real network structure to send telegrams in different telegram rates. EOP350 has been used to read the telegrams and send them to the computer. At the beginning, one floor unit has sent 10 telegrams at a rate of 1, 2, 3, 4, 5, 10, 15, 20, 25 and 30 telegram/s. When all telegrams have been received

by the telegram reader, the telegram success rate has been considered 100 % and the transceiver module has not reached the bottleneck point yet. For the next step, 2 floor units have been used and each one has sent 10 telegrams at the same telegram rates. The same process has been repeated up to 5 floor units. Results of Experiment 1 showing variations of telegram success rate and telegram window with variation of active floor unit number are given in Figures 7-12. The term telegram window describes the time each telegram requires to be sent, e.g. in Figure 7 when only one floor unit sends telegrams at a rate of 1 telegram/s , the telegram window is 1000 ms but in case of two floor units each operating at a rate of 1 telegram/s, the telegram window is 500 ms. As a result of this experiment, 100 % telegram success rate has been achieved until the telegram intensity, i.e. the total number of telegrams sent per second, has reached about 75 telegram/s corresponding to a telegram window of 13.33 ms. Beyond this point, telegram success rate has started to degrade and at a telegram intensity of 100 telegram/s it has decreased to about 80 %.

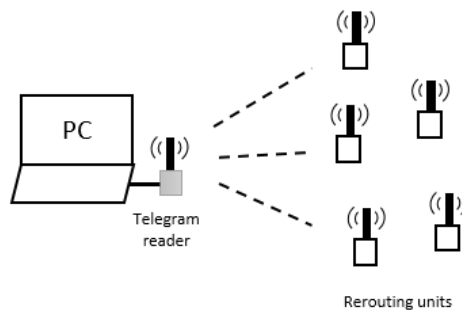

Figure 6:
Experimental setup for telegram success rate & telegram intensity measurements

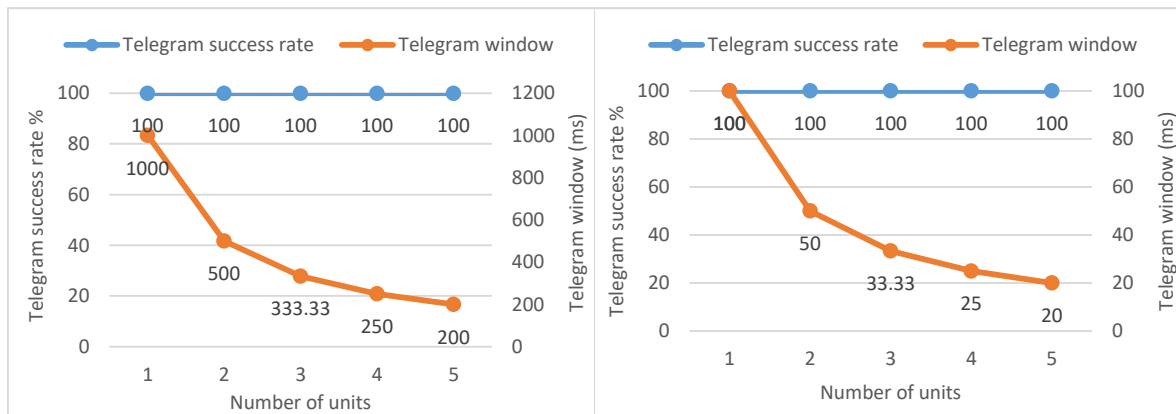

Figure 7:
Telegram success rate and telegram window vs. number of active floor units
(Telegram rate is 1 telegram/s for each active floor unit)

Figure 8:
Telegram success rate and telegram window vs. number of active floor units
(Telegram rate is 10 telegram/s for each active floor unit)

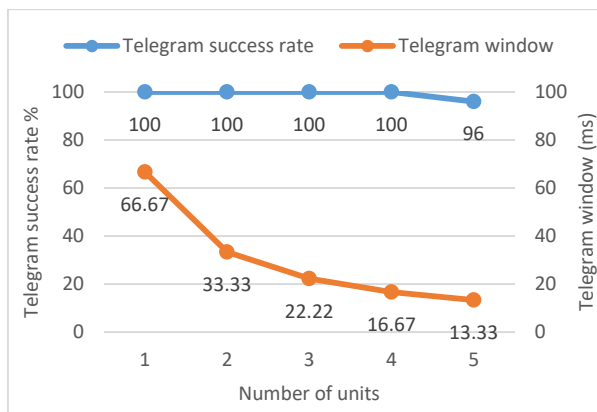

Figure 9:
Telegram success rate and telegram window vs. number of active floor units (Telegram rate is 15 telegram/s for each active floor unit)

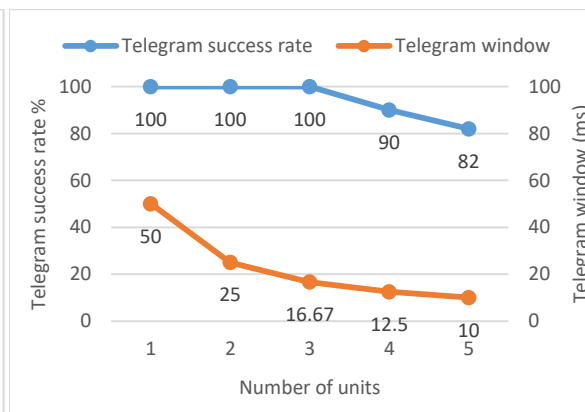

Figure 10:
Telegram success rate and telegram window vs. number of active floor units (Telegram rate is 20 telegram/s for each active floor unit)

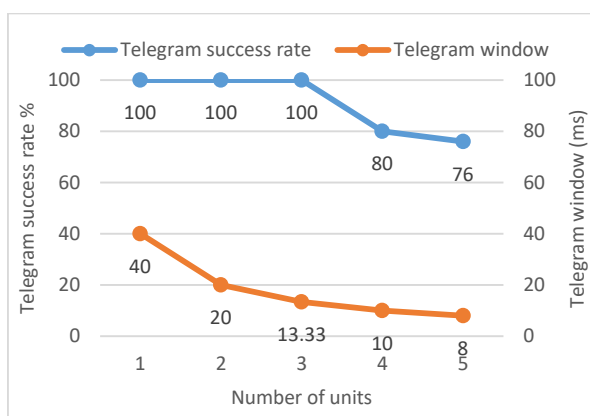

Figure 11:
Telegram success rate and telegram window vs. number of active floor units (Telegram rate is 25 telegram/s for each active floor unit)

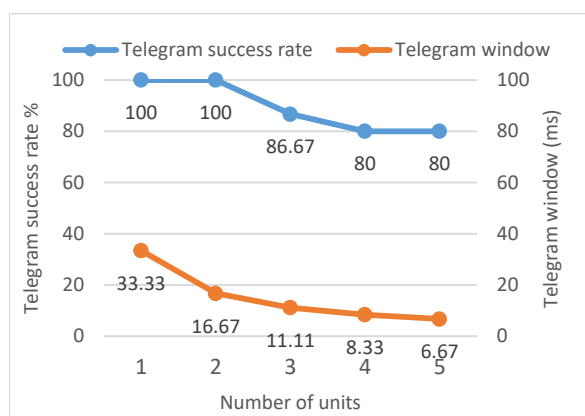

Figure 12:
Telegram success rate and telegram window vs. number of active floor units (Telegram rate is 30 telegram/s for each active floor unit)

4.2. Experiment 2: Hop Time Measurements

Experiment 2 has been performed in a laboratory to measure the average hop time of the proposed network. The experimental setup has been shown in Figure 13. Since the experiment has been done under laboratory conditions, the data propagation time through the air for the real network structure has been ignored in the measurements. Since TCM320 transceiver and USB300 device use the same firmware, their processing times spent for reading wireless data are almost the same. Thus, processing time of USB300 device has resolutely been taken into consideration. In this experiment, a telegram from point 1 to CP has been sent through the

multi-hop network, and all telegrams sent by floor units have been read by USB300 device. The telegram sent from point 1 to CP is rerouted by point 3 and point 5. Thus, USB300 device receives a total of 3 telegrams. The difference between arrival times of the first and the second telegrams to USB300 and the difference between arrival times of the second and the third telegrams to USB300 have been considered as the first hop time and the second hop time, respectively. To get more precise values, the experiment has been performed 10 times and the average hop time has been calculated. The average times of the first hop and the second hop are 16.1 ms and 17.5 ms, respectively. Figure 14 and Figure 15 show the measured values. Figure 15 shows that there is a relatively long delay in the second hop when the second telegram has been sent. This could possibly be the result of USB300 not being able to receive the first subtelegram of the telegram in question or busyness of the radio channel causing a delay in sending the subtelegram.

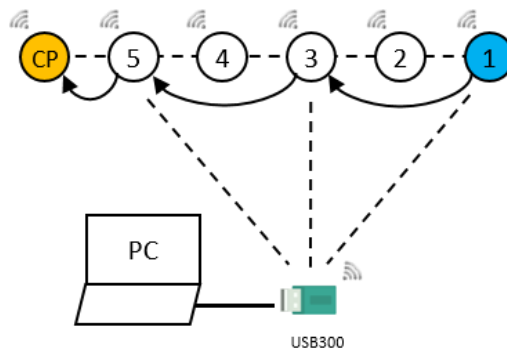

Figure 13:
Experimental setup for hop time measurements

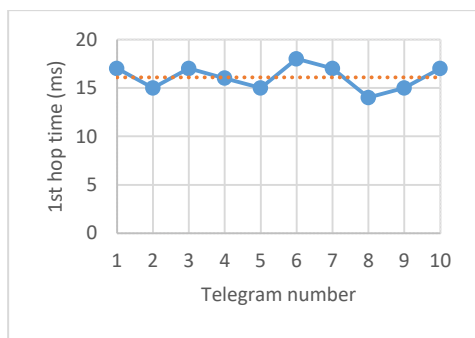

Figure 14:
Experimental results for the first hop time

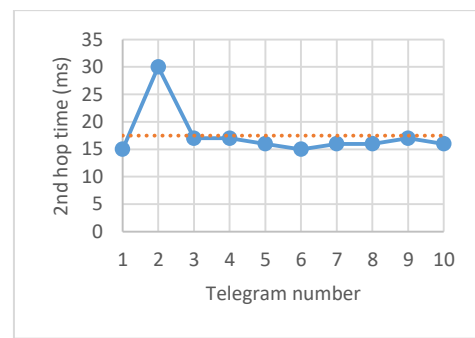

Figure 15:
Experimental results for the second hop time

4.3. Experiment 3: Signal Power Measurements

The main purpose of this experiment is to measure the signal power of the TCM320 transceiver module. The experiment has been performed in a building that has a 257.5 cm floor height and a 19.5 cm flooring thickness. The floor plan of the building is shown in Figure 16. The power of telegrams sent by a fixed floor unit in the ground floor has been measured on each floor by using EOP350 equipped with a TCM320 module and connected to a laptop computer. Each measurement has been done 5 times to get the average value for a more precise result. Antennas have been horizontally positioned as shown in Figure 17. Figure 18 shows that average signal power is -60.8 dBm, -58 dBm, -73.2 dBm, -88.2 dBm, -83 dBm, -92 dBm at floors 1, 2, 3, 4, 5, 6, respectively. For the designed network, knowing that TCM320 module has

a receiving sensitivity of -96 dBm, and taking into consideration that double-jump hops are used, a signal power of -58 dBm at the second floor is more than sufficient since there is a 38 dBm safety margin away from the receiving sensitivity of the transceiver. It has been expected to measure continually decreasing signal power values moving away from floor 1 up to floor 6, but signal power witnessed fluctuations in its values. The reason of this could be the structure of the building in question or inhomogeneity in flooring structure of each floor.

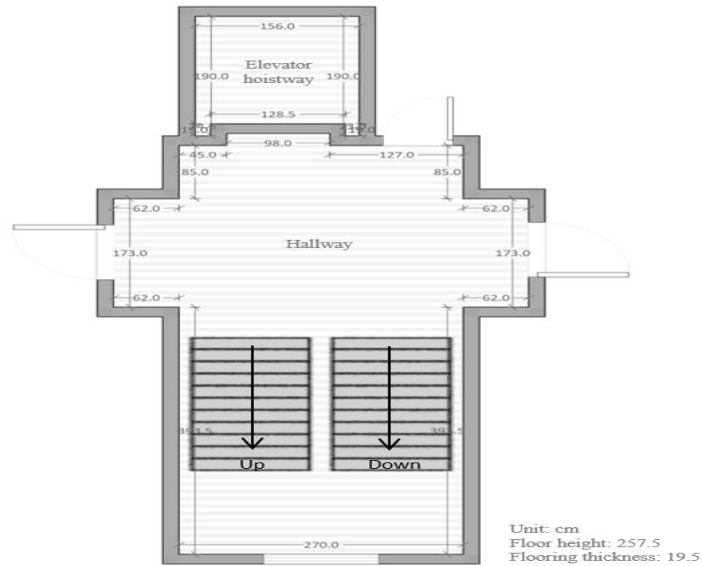

Figure 16:

The floor plan of the building in which the signal power experiment has been performed

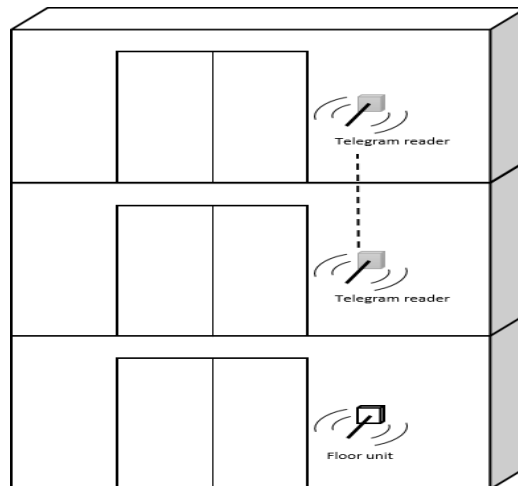

Figure 17:

Experimental setup for signal power measurements

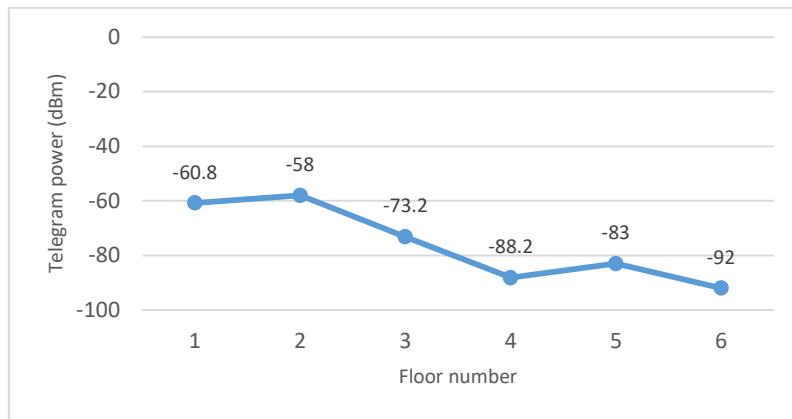

Figure 18:
Telegram average power at each floor

5. A NETWORK DEVELOPMENT SUGGESTION

Results of experiments show that performance of the proposed network decreases when the telegram intensity exceeds 75 telegram/s. Furthermore, data propagation time increases with increasing number of hops which makes multi-hop networks hard to be employed in high-rise buildings. Therefore, a hybrid wired-wireless network that may overcome limitations of the proposed network in high-rise buildings is introduced in this section.

The hybrid wired-wireless network consists of two types of communication systems; the first one, which is wired, uses CANbus protocol, while the second one, which is wireless, uses WSP protocol. The network is designed so that it is divided into groups consisting of a maximum five points. Each group includes a point called Group Master (GM) that supports both types of the already mentioned communication systems. GM is responsible for conveying data back and forth between all other points in the relevant group, i.e. End Points (EPs), and the control panel. Figure 19, where point 3 is the GM, shows a 5-floor network while Figure 20, where points 3 and 8 are GMs of relevant groups, shows a 10-floor network. Figure 21 shows different scenarios for routes of messages sent in a 5-floor hybrid wired-wireless network.

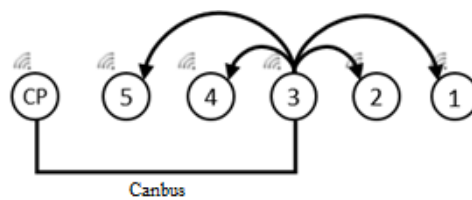

Figure 19:
5-floor hybrid wired-wireless network

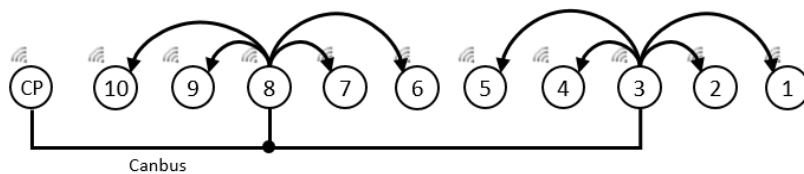

Figure 20:
10-floor hybrid wired-wireless network

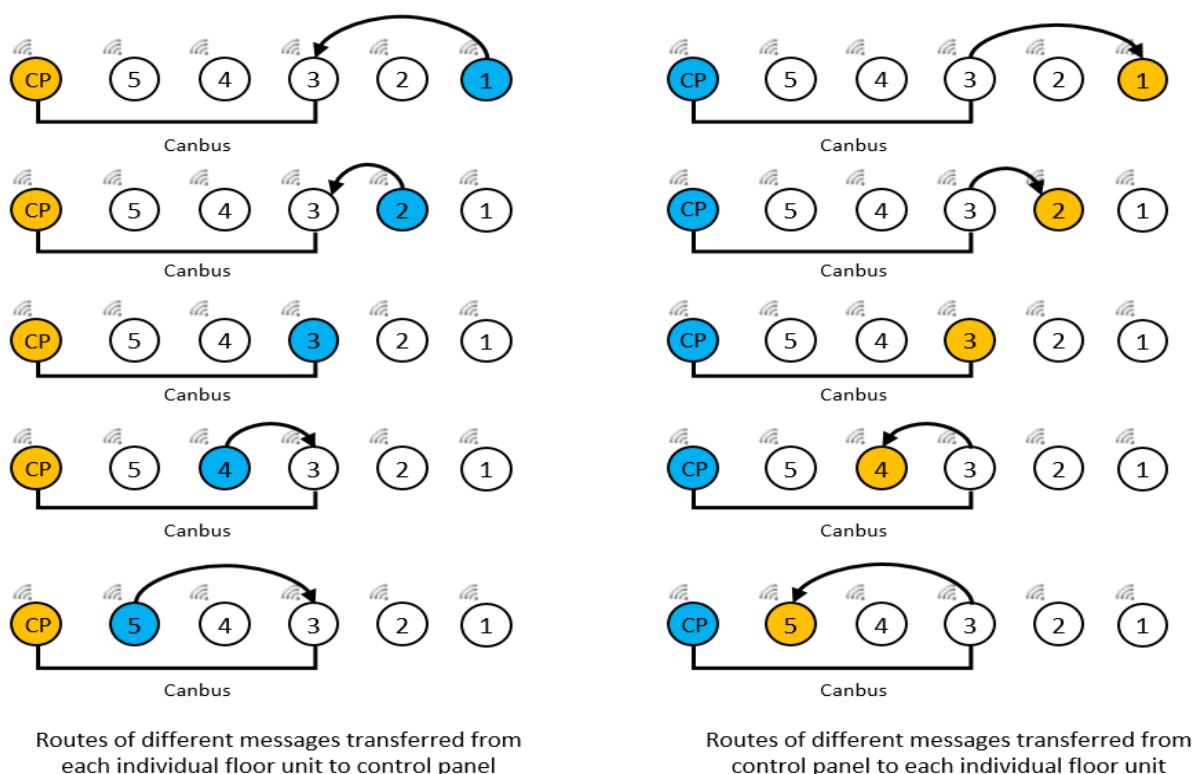

Figure 21:
Routes of messages sent in a 5-floor hybrid wired-wireless network

In this network, routing tables contain addresses of points from which the relevant point can receive messages. Based on this, each GM contains addresses of all EPs in the relevant group, whereas each EP contains just the address of the GM in the relevant group. When a GM receives a message from the control panel, it searches the destination address of the message in its own routing table. If the address exists in the table, GM routes the message wirelessly to the destination EP or if the message destination address is the own address of GM, it executes the message. Otherwise the message is ignored. When a GM receives a message from an EP wirelessly, it searches in its own routing table for that EP address. If the address exists, it means that EP belongs to the same group with GM and the message will be routed to the control panel through CANbus connection. Otherwise the message is ignored.

6. CONCLUSION

A double-jump multi-hop wireless network for low-rise and medium-rise buildings has been proposed in this paper to control elevator floor fixtures using WSP protocol. Performance of the proposed network has been tested with three experiments focusing on the telegram success rate, the hop time and the signal power.

In the first experiment, while testing the maximum operating speed of TCM320 transceiver module, it has been found that a telegram intensity less than 75 telegram/s guarantees 100 % telegram success rate. For telegram intensity values exceeding 75 telegram/s the telegram success rate degrades, e.g. the telegram success rate decreases to about 80 % at a telegram intensity of 100 telegram/s. Telegram success rate is considered as an important factor helping to find maximum limitations of the proposed network.

The reliability and the hop time are two of the most important factors in designing a multi-hop network to control the floor fixtures of an elevator. Regarding the reliability improvement,

two mechanisms used by WSP protocol have been discussed i.e. iterating data three times and the LBT technique. On the other hand, the average hop times have been obtained as 16.1 ms for the first hop and 17.5 ms for the second hop in Experiment 2. Those values allow the network to be implemented in low-rise and medium-rise buildings.

The purpose of the third experiment, where the signal power of TCM320 transceiver module has been measured, was to find whether the proposed network can perform double jumps effectively or not. It has been found that the signal power of the transceiver module at a 2-floor distance is -58 dBm, which is a sufficient value since the receiving sensitivity of the module is -96 dBm. As a result of this experiment it can be concluded that the network may be capable of performing even triple jumps or more which contributes to the speed, telegram intensity and the performance of the network.

Using WSP protocol allows the proposed network to be integrated into home automation and building management systems. Utilizing this technology in elevator industry will increase the quality of the service provided to customers. There are many sensors in the market which are already built and ready to use, and they can be easily integrated into the proposed network.

On the other hand, using ASK or FSK modulation forces to take a few precautions. Even though floor units are not distributed inside the embodiment, thus, wireless signal is not going to be affected too much by reflections resulting from the embodiment and the movement of the cabin, precautions must be taken while mounting floor units. Spectrum analyzer should be used to get sure that floor units are not located in positions vulnerable to multipath cancellation effect. Other devices that use the same frequency should be reduced as much as possible otherwise telegram success rate could be affected negatively.

Predicting possible performance limitations of the proposed network in high-rise buildings, a network development suggestion for high-rise building has also been made. It is a hybrid wired-wireless network based on the proposed network benefiting from advantages of both wired and wireless systems. Contrary to the case in the proposed network, the time a message requires to be sent from CP to a floor unit and vice versa is almost constant for all floor units in the hybrid wired-wireless network. Therefore, the hybrid network does not heavily depend on the number of floor units. Canbus protocol allows the network to be implemented in high-rise buildings providing high speed and high reliability while the wireless network not only does help to decrease elevator installation time and fault troubleshooting time but also helps to increase the flexibility of the system and to provide a better service overall.

Our further studies are planned to focus on

- perturbative factors such as reflection, interference and noise that must be overcome for reliable implementations of the proposed network in low-rise and medium-rise buildings.
- the performance analysis of the hybrid wired-wireless network in high-rise buildings.

REFERENCES

1. Anders, A. (2005). *Pushbutton Transmitter Device PTM 200 User Manual V1.1*, EnOcean GmbH, Germany.
2. Ansari, I. S. (2009). An implementation of traffic light system using multi-hop ad hoc networks, *International Conference on Network-Based Information Systems (NBIS'09)*, Indianapolis, USA, 177-181. doi: 10.1109/NBiS.2009.8
3. Crenella, D., Gozzo, M. P., Grzybowski, R. R., Izard, J. M., Morgan, R. G. and Slabinski, C. J. (2003). Two-part wireless communications system for elevator hallway fixtures, USA Patent, US 6601679 B2.

4. Đurišić, M. P., Tafa, Z., Dimić, G. and Milutinović, V. (2012). A survey of military applications of wireless sensor networks, *Mediterranean Conference on Embedded Computing (MECO'2012)*, Bar, Montenegro.
5. EnOcean GmbH (2015a). *EnOcean Equipment Profiles EEP Version 2.6.3*, Germany. https://www.enocean.com/fileadmin/redaktion/enocean_alliance/pdf/EnOcean_Equipment_ProfilesEEP_V2.6.3_public.pdf (Last Access Date: 09.03.2018)
6. EnOcean GmbH (2015b). *EnOcean Developer Kit: EDK 350 User Manual*, Germany.
7. https://www.enocean.com/en/enocean_modules/edk-350/user-manual-pdf/ (Last Access Date: 09.03.2018)
8. EnOcean GmbH (2017a). *EnOcean TCM 300 / TCM 320 (868 MHz), TCM 300U / TCM 320U (902 MHz) Transceiver Module User Manual*, Germany. https://www.enocean.com/de/enocean_module/tcm-300/user-manual-pdf/ (Last Access Date: 09.03.2018)
9. EnOcean GmbH (2017b). *EnOcean Serial Protocol 3 (ESP3)*, Germany.
10. EnOcean GmbH (2017c). *USB 300 / USB 300U / USB 400J USB Gateway for EnOcean Radio*, Germany. https://www.enocean.com/en/enocean_modules/usb-300-oem/user-manual-pdf/ (Last Access Date: 09.03.2018)
11. Furtado, H. and Trobec, R. (2011). Applications of wireless sensors in medicine, *34th International Convention MIPRO'2011*, Opatija, Croatia, 257-261.
12. ISO/IEC 14543-3-10 (2012). Information technology -- Home electronic systems (HES) architecture --Part 3-10: Wireless short-packet (WSP) protocol optimized for energy harvesting -- Architecture and lower layer protocols, International Organization for Standardization, Geneva, Switzerland.
13. Motoyama, N., Inaba, H., Kawabata, A., Ohkura, Y. and Yamashita, K. (2002). Elevator system having wireless transmitting/receiving units, USA Patent, US 6446761 B1.
14. Oh, J. H. and Hootsmans, N. A. M. (2012). Elevator system with wireless hall call buttons. USA Patent, US 8253548 B2.
15. Shibata, Y., Sato, Y., Ogasawara, N. and Chiba, G. (2009). A disaster information system by ballooned wireless adhoc network, *International Conference on Complex, Intelligent and Software Intensive Systems (CISIS'09)*, Fukuoka, Japan, 299-304. doi: 10.1109/CISIS.2009.191
16. Venables, M. (2017). Lifting maintenance to new heights, *Plant Engineer*, 2017 (5-6), 6-9.
17. Wark, T., Corke, P., Sikka, P., Klingbeil, L., Guo, Y., Crossman, C., Valencia, P., Swain, D., Bishop-Hurley, G. (2007). Transforming agriculture through pervasive wireless sensor networks, *IEEE Pervasive Computing*, 6 (2), 50-57. doi: 10.1109/MPRV.2007.47

