



Developments and Applications in Enzyme Activated Membrane Reactors: A Review

Nadir Dizge ^{1*}, Ruken Esra Demirdogen ², Kasim Ocakoglu ³

¹Mersin University, Department of Environmental Engineering, 33343, Mersin, Turkey.

²Cankiri Karatekin University, Department of Chemistry, 18100, Cankiri, Turkey.

³Tarsus University, Department of Energy Systems Engineering, 33400 Tarsus, Turkey

*Corresponding Author email: ndizge@mersin.edu.tr

Abstract

Enzyme immobilization has been significant in applying polymer membranes to prevent biofouling or to create catalytic reactions. So far, several modification methods have been employed for modifying surface of membranes. Among these methods, enzyme immobilization on polymeric membranes have gained much attention. Enzymes can be immobilized either via physical or chemical methods. This review summarizes the recent literature on modification of polymer membranes using various immobilization techniques.

Key words

Polymeric membranes, enzyme activated membranes, enzyme immobilization, membrane reactor, catalytic membrane separation process

1. INTRODUCTION

Membrane technologies have been widely used for reducing water consumption, reusing and recycling treated water, and producing freshwater via desalination. Membrane treatment offers better water quality when compared with other treatment methods. However, membranes can be used as reactors for achieving simultaneously catalytic reactions and separation process. Membrane reactors, which benefit from collaboration of different disciplines such as chemical reaction engineering, separation technology, materials science, also mathematical modelling aspects. They couple chemical reactions with membrane separation and provide a cost effective and more system design besides improved performance with regard to selectivity and/or yield [1]. Extensive research is still going on to modify membrane surfaces and enzyme immobilization on polymeric membranes to obtain biocatalytic membrane reactors.

In this review, recent developments, applications and future perspectives in enzyme activated membrane reactors are discussed.

2. CATALYTIC MEMBRANE REACTORS

Membranes are semi-permeable thin layer of materials capable of separating contaminants as a function of their physical or chemical properties and therefore they have been preference of choice in clean and valuable separation processes as well as for removal of suspended particles and microorganisms [2]. There are different types of membranes which can be classified according to their pore sizes and charge affinity. Therefore, they are utilized in a wide range of applications such as microfiltration (MF), ultrafiltration (UF), nanofiltration (NF) and reverse osmosis (RO) [3].

When rejected macromolecules or other substance solutes are adsorbed in the pores of the membranes plugging occurs which causes membrane fouling [4]. The factors, which are responsible for membrane fouling can be grouped under three main categories [5,6]: (i) feed suspension properties such as particle size, particle concentration, pH and ionic strength), (ii) membrane properties such as hydrophobicity, charge and pore size), and (iii) hydrodynamics such as cross-flow velocity, transmembrane pressure.

There is an increasing interest in producing biocatalytical membrane surfaces by immobilizing enzymes on membranes for to obtain catalytical membranes as well as for to minimize membrane fouling so that these membrane systems can be employed as reactor. There are many reactor types currently in use today. Among many reactors immobilized enzyme membrane reactor (ImEMR) is usually preferred as a suitable platform for continuous reactor operation that does not require an additional step to recover the enzyme [7,8].

3. ENZYME DEFINITION

Catalysts are used for increasing reaction rates without being a part of the reaction products [9]. Enzymes, which are the biological catalysts, have high specificity and catalyze or in other words increase the rate of one or few closely related chemical reactions without altering the equilibrium state. Enzymes acting as catalyst lower the activation energy and thus increase the rate of the reactions in the cells, which would not have occurred even over time periods of years, and enable these reactions occur in fractions of seconds and finally attain the equilibrium state (Figure 1). If enzymes had been absent most cellular reactions would not have even occurred and if cellular reactions had not been fast it would be impossible to see life in its present form. As any other catalyst enzymes themselves also undergo transient changes during the reactions. However, in the overall process, enzymes do not undergo any net change [10]. Enzymes as catalysts take place in some vital processes such as:

- 1) regulating the structure and function of cells and organisms,
- 2) synthesizing and breaking down biochemical building blocks and macromolecules,
- 3) transmitting genetic information,
- 4) transporting compounds across membranes,
- 5) providing motility of organisms,
- 6) converting chemical energy,
- 7) enable biochemical reactions proceed at the necessary rate in physiological conditions.

One of the most basic and characteristic feature of enzymes is their specificity. To state it in other words, each reaction in the cell is catalyzed by its own, specific enzyme. Specificity of enzymes depends both on the structure of the enzyme and the active sites where the substrate molecule -the substances upon which enzymes act- binds on the enzyme. Substrate do not necessarily have to be small molecules they can also be macromolecules like the enzyme itself like trypsin which is the enzyme that uses polypeptides as substrates and acts on them by hydrolysing the peptide bonds [10]. Enzymes function over the mechanism that proceeds through binding to the substrate at the beginning via non-covalent interactions such as hydrogen bonds, ionic bonds and hydrophobic interactions.

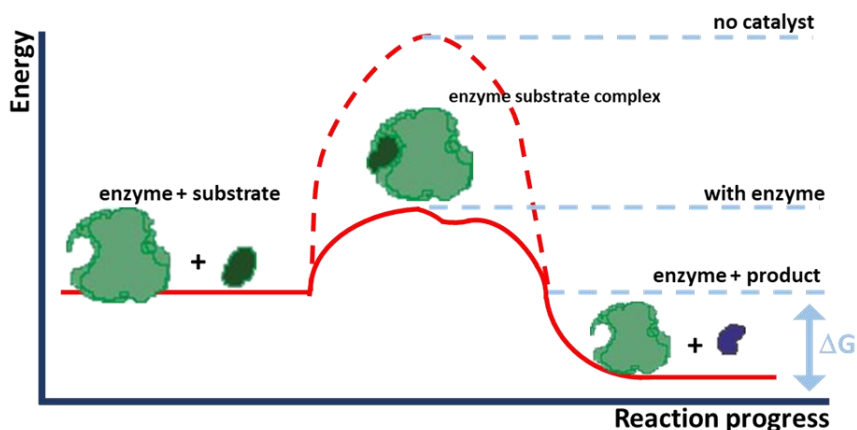

Figure 1. Activation energy versus reaction progress for a catalyst

Enzyme Immobilization Techniques

Enzyme engineering, which heavily relies on enzyme applications and thus mostly benefits from enzyme immobilization as a powerful tool, plays a vital role in the biotechnological processes [11,12]. Incorporation of enzymes in artificial membranes perform bio-chemical transformation of substrates during filtration of feed solution and doing this in a continuous mode with improved stability and activity has gained much importance [13,14]. These bio hybrid systems, which can be considered micro or nano chemical reactors, have become a breakthrough in membrane technology [15].

The success of enzyme applications is related to the success of enzyme immobilization which depends on the following criteria: (i) resistance of enzyme to leaking, (ii) high enzyme activity which can be retained over a long-term use and storage; (iii) no unfavorable alterations in kinetic properties; (iv) immobilization matrix should be negligible diffusional limitation and fouling; (v) sustained operational stability under adverse environmental conditions; (vi) fast catalytic activity exhibited by enzymes; (vii) proper enzyme immobilization density with adequate orientation; (viii) reasonable operational costs and additional costs (i.e. carrier and fixing agents and immobilization process), (ix) easy access to immobilized matrixes (or support materials) [11]. The last criteria indicate that proper selection of the support materials (i.e. solid beads, porous particles or membranes) plays a key role in enzyme immobilization. This selection can be made either according to the chemical (i.e. hydrophilicity, hydrophobicity, ionic charges) or geometric properties (i.e. shape, size, porosity, pore size distribution) of the support material [11,16,17].

The structural or the geometric properties of the support material such as the particle shape and size have profound effect on the intrinsic activity of the enzyme-loaded particles [11,18]. For instance, the carriers with spherical shape have large surface area and high enzyme loading capability. Particles with pore sizes in the 10 to 100 μm range – micro particles – have been preferred in food, pharmaceutical, biofuel cell production, and bioremediation [9,11]. However, particles with pore sizes $<0.1 \mu\text{m}$ – nanoparticles – have mostly been preferred in medical applications such as biological/chemical sensing, drug delivery and disease diagnostics [19].

Depending on their chemical properties carriers can be categorized as inorganic and polymeric materials. Due to the favorable mechanical properties and facile tailorability of the latter category polymeric materials have become preference of choice in most of the applications [20]. Moreover, chemical properties of the support material determine the route of immobilization. That is to say whether immobilization will go through the route of binding to the support (physical adsorption, ionic bonding and covalent bonding) or will be via entrapment as well as encapsulation within the support, or cross-linked on the support. A schematic illustration of enzyme immobilization methods is presented in Figure 2.

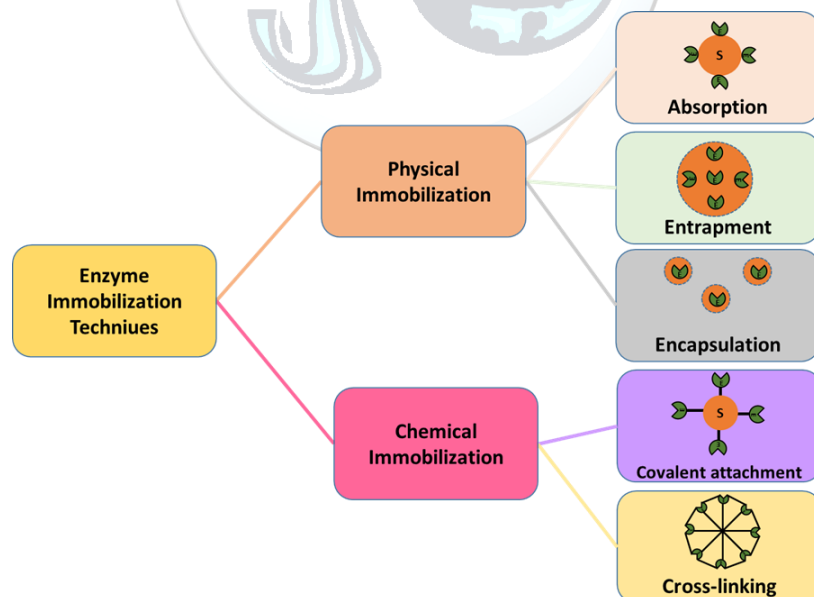

Figure 2. Schematic explanation for enzyme immobilization techniques

A key factor in enzyme immobilization is choosing the appropriate support since to a great extent the nature of the support and its bonding with the enzyme is the determining step regarding the efficiency of the enzyme. Therefore, it is necessary that the support has high affinity or capacity for enzymes. Moreover, the chemical structure of the support should enable the interaction between the enzyme and the substrate be maximum. Besides favorable

chemical properties, an appropriate support should have thermal resistance, chemical durability and be resistant against contamination and fouling and at the same time be cost effective [21]. Additionally, a preferred immobilization technology should have the following features: (i) enzyme reuse; (ii) favorable working pH and temperature; (iii) product separation should be easy; (iv) possibility of co-immobilizing different enzymes reactor design should be simple; (v) wider choice of reactors [22-24].

When working with enzyme immobilized membranes it is a key factor to avoid deactivation of the enzyme. Since the substrate is retained in the reactor for a much shorter time than the immobilized enzyme, immobilized enzyme membrane reactors is much more efficient than batch operations on the condition that the immobilized enzymes are replaced with fresh enzymes for the purpose of cleaning the membrane when the membrane gets oversaturated with the substrate [25,26]. Therefore, reactors play a key role in the success of the operation of the immobilization technology.

4. DIFFERENT TECHNIQUES FOR ENZYME IMMOBILIZATION ON POLYMERIC MEMBRANES FOR BIOCATALYTIC REACTORS

4.1. Physical Immobilization on Polymeric Membranes

4.1.1. Adsorption

Adsorption is the method of preference for enzyme immobilization due to its simplicity. One of its main disadvantages is its limited turn over number since the enzyme leaks from the matrix. In a research conducted by Giorno et al. [27] a multiphase enzyme-loaded membrane system was used for investigating mass transfer performance of naproxen acid and ester [27]. This system was preferred for preparing two-separate phase enzyme membrane reactor (TSP-EMR). The experimental set-up is presented in Figure 3. The TSP-EMR was used for converting racemic ester of naproxen into the corresponding S-naproxen acid in an enantioselective manner. Since the transport kinetics of the system were investigated when there was no biochemical reaction, the overall mass transfer coefficients of naproxen ester, which is the reactant, and S-naproxen acid, which is the product, through the TSP-EMR was measured via loading a deactivated enzyme on the membrane. This loading was carried out under two different conditions, which are either the enzyme was immobilized alone on the membrane or the enzyme was immobilized in the presence of oil/water (o/w) emulsion, which constitutes the multiphase system, where the organic and the aqueous phase are separated by a polymeric membrane. The transport rate of naproxen acid, which is polar in nature, and naproxen ester, which is apolar in nature, through the polymer membrane (50 kDa molecular cut-off), hydrophilic in nature, and through the enzyme immobilized membrane systems in the presence and absence of o/w emulsion were evaluated. The membrane was placed in upright position and no pressure was applied from neither side of the membrane (TMP = 0) (Figure 3).

The transport rate of naproxen acid from shell-to-lumen was measured at 30 °C with initial acid concentration of 2.53 mM in the reservoir of shell side. The shell and lumen sides were found to have Reynolds (Re) numbers of 17.0 and 122.1, respectively. The results revealed that the change in concentration of naproxen acid in the shell and lumen sides would be asymptotic. The relationship between the change in the concentration of Naproxen acid in the lumen side and the contact time between the solutions on the shell and the lumen sides was in direct and linear proportion. It was found that after 22 h continuous operation the concentration of naproxen acid in the lumen side was around 0.34 mM and under these experimental conditions the transfer rate of naproxen acid was about 4.21×10^{-6} mM^s⁻¹.

The transport of naproxen ester through the membrane from the shell to the lumen side at 30 °C was investigated with (R,S)-naproxen ester with an initial concentration 2.50 mM in the reservoir of shell side was investigated. The Reynolds numbers in the shell and lumen sides were found to be 30.6 and 157.0, respectively. The change in the concentrations of naproxen acid and naproxen ester in the membrane were similar to each other. Under the said experimental conditions, the transfer rate of naproxen ester was about 7.8×10^{-8} mM^s⁻¹. The transfer rate of naproxen acid was two orders of magnitude more than the transfer rate of naproxen ester.

The transport kinetics (i.e. transport rate and the overall mass transfer coefficient of naproxen acid and naproxen ester) as a function of fluid dynamic parameters (i.e. axial velocity) were investigated. It was observed that K_{ov} and the axial velocity was directly proportional with each other, but K_{ov} for naproxen acid ($\sim 10^{-7}$) was higher than that for naproxen ester ($\sim 10^{-9}$). It was also observed that presence of emulsion during immobilization of the enzyme improved the mass transfer of naproxen ester through the membrane. It was reported that knowing the mass transfer properties of both naproxen acid and the ester that is of the reactant and the product enabled the reactor to be used at the highest performance for the enantioselective hydrolysis of racemic mixtures of naproxen methyl ester into S-naproxen acid.

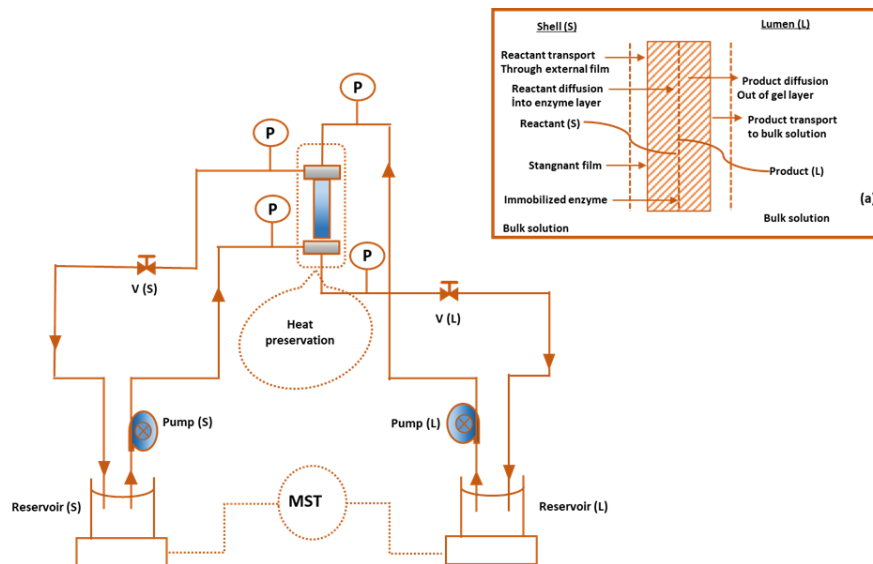

Figure 3. Schematic diagram of the TSP-EMR (*V*: stands for valve; *S*: for shell side; *L*: for lumen side; *MST*: for magnetic stirrer with temperature controller and *P*: manometer. The arrows show the direction of the flow in the system) [27].

Xu et al. have reported a method for fast protein digestion via stable microporous reactor prepared by a simple and cost-effective method based on sequential adsorption of poly(styrene sulfonate) and trypsin in nylon membranes [28]. Proteolysis was facilitated by the high local trypsin concentration and short radial diffusion distances in membrane pores that occurred in a few seconds. Since the pressure drop across these thin membranes was small these membranes were appropriate for use in syringe filters. After bovine serum albumin was digested via the membranes and 84% sequence coverage was attained. This was higher than the coverage obtained with a 16 h in-solution digestion, which was 71%, and that was obtained by other methods utilizing immobilized trypsin, which was less than 50%. Protein digestion in membranes modified with trypsin occurs when 0.05 wt% sodium dodecyl sulfate (SDS) is present. However, at the end of in-solution digestion under similar conditions no peptide signal is observed in the MS spectra. It was observed that presence of SDS had no effect in this. This study reports that the shelf life of these membrane reactors is not less than several months and these membranes can digest protein continuously for more than 33 h while maintaining their activity considerably.

As presented in Figure 4, the solution, which pass through the commercially available polymer membranes, separates into many streams. The micrometer-size pores of these membranes cause the radial diffusion distances between the solution and the wall of these membranes to be short ($\sim 1 \mu\text{m}$). Therefore, these membranes are considered to be similar to monoliths.

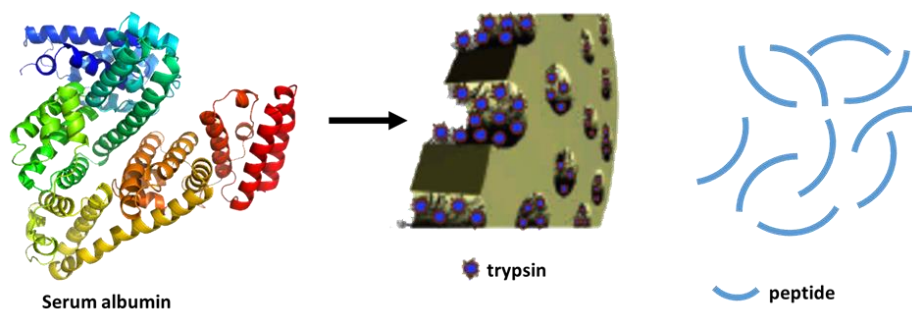

Figure 4. Schematic presentation of a membrane reactor for tryptic digestion [28].

As can be seen in Figure 5, a 4 mm disk was cut from a 25 mm-diameter membrane modified with trypsin and inserted in an Upchurch low-pressure in-line filter system where a frit was placed between the membrane and the downstream tubing for samples of a few microliters.

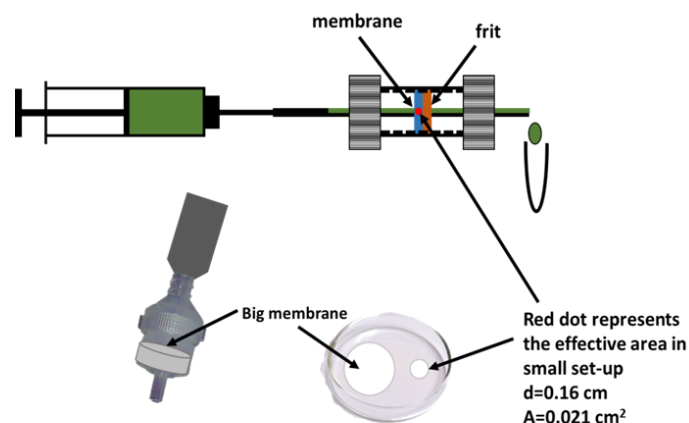
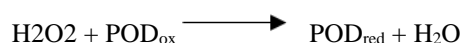

Figure 5. Schematic presentation of the miniaturized membrane holder (top), the Swinnex Holder (bottom left), and a photograph (bottom right) of the 25 mm membrane disk and a miniaturized membrane [28]

Trypsin concentration in the membrane pores was found to be high when PSS and trypsin were sequentially adsorbed in nylon supports. This provided proteolysis to occur in short residence times of a few seconds. MALDI-MS results revealed that the protein sequence coverage achieved in digestion of R-casein by membranes was similar or higher than that obtained in in-solution digestion. It was observed that the MS detectable peptides obtained in BSA digestion, in-solution digestion and other digestion techniques such as those using trypsin immobilized monoliths was at least 1.4 times less than that obtained via digestion in membranes. Miniaturized membranes provide several advantages such as low sample consumption (i.e. a few microliters) and short processing times (1.7 μL solution/min). Moreover, if the conditions are optimized this time may decrease significantly. On the other side, when immobilized trypsin is used digestion may even take place in solutions containing 0.05% SDS. However, no MALDI-MS signal was observed for solution digestion under similar conditions even when SDS was removed from the solution by cation-exchange before the analysis. It is expected that trypsin-modified membranes would facilitate protein analysis due to the advantages they offer such as long-term stability and simple fabrication and those mentioned above [28].

4.1.2. Entrapment

Amounas et al. [15] used entrapment method to immobilize glucose oxidase (GOD) and peroxidase (POD) enzymes in a polypyrrole matrix by an avidin–biotin molecular recognition process. The mechanism is given as follows:



The enzymes were immobilized in electro-polymerized polymer using a biotin labeled pyrrole precursor. The amount of enzyme entrapped in the polymeric matrix was 60% and 83% for GOD and POD, respectively. The fabricated enzyme activated membranes showed a good performance during the permeation of the substrates which were glucose and hydrogen peroxide for GOD and POD enzymes, respectively. The reactive membranes catalyzed the oxidation of glucose in the presence of oxygen by GOD activated membrane whereas the reduction of hydrogen peroxide in the presence of the oxidant pyrogallol by POD activated membrane. The enzyme activated POD membrane exhibited excellent stability with less than 6% decrease of activity when stored for 80-day. They concluded that enzymatic membranes can be used for the treatment of aqueous media due to high enzyme immobilization and stability [15].

Giorno et al. [27] immobilized in a polyamide capillary polymeric membrane by entrapment method using the lipase from *Candida rugosa* to develop a multiphase enzyme membrane reactor. The reactor was designed to have a configuration of a two separate phase emulsion enzyme membrane reactor (TSP-E-EMR) and two separate phase enzyme membrane reactor (TSP-EMR) (Figure 6).

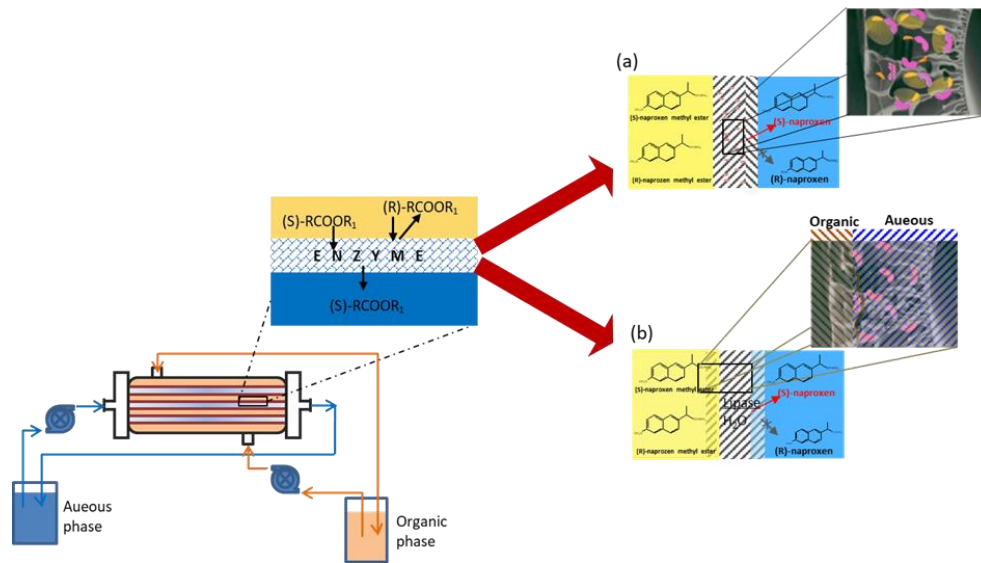

Figure 6. Schematic representation of the membrane reactors used: (a) the two separate phase emulsion enzyme membrane reactor (TSP-E-EMR) and (b) the two separate phase enzyme membrane reactor (TSP-EMR) [27].

A stable and uniform oil-in-water emulsion was prepared by membrane emulsification. The enzyme was used in free form and it was performed using triglycerides as substrate in a stirred tank reactor. The results indicated that the specific activity of the enzyme in the presence and absence of emulsion was the same and organic phase did not hinder enzyme performance. TSP-E-EMR and TSP-EMR reactors were also tested with triglycerides present in olive oil as substrate. It was observed that productivity increased from 5.2×10^{-4} mmol/min to 4.94×10^{-3} mmol/min. The results showed that the presence of the emulsion had significantly improved the catalytic activity in the reactor. The presence of emulsion increased the mass transport of the hydrophobic substrate through the membrane and immobilization improved enzyme stability [27].

In a study by Bohdziewicz [29], the possibility of phenol biodegradation in coke wastewater by enzymes isolated from a bacterial strain of *Pseudomonas sp.* was investigated. The enzyme was immobilized in the porous structure of an asymmetric polyacrylonitrile ultrafiltration membrane. The influence of process parameters such as transmembrane pressure (ΔP), stirring rate, and feed concentration of phenol on the effectiveness of ultrafiltration enzymatic membranes was systematically investigated.

When the transmembrane pressure was increased from 0.5×10^5 to 1.0×10^5 Pa the permeate flux increased at a 49% ratio. Further increasing in ΔP from 1.0×10^5 to 2.0×10^5 Pa and from 2×10^5 to 3.0×10^5 Pa increased the permeate flux by 57% and 23%, respectively. Nevertheless, it cannot be said that there is a linear relationship between the flux and the pressure for the enzymatic membranes examined. An increase in pressure does not always mean an increase in the flux. However, as the pressure increased in the range from 0.5×10^5 to 1.0×10^5 Pa the degree of phenol biodegradation also increased (from 23 to 33%). The stirring rate also affected both the permeate flux and the phenol biodegradation. An increase-in the stirring rate up to 500 rpm caused an 8% increase in the permeate flux. However, the degree of phenol biodegradation reached the maximum value (27%) at 400 rpm and did not change for stirring rate between 400 and 500 rpm. Feed concentration of phenol was tested for the range from 1 to 7 g/L. The permeate flux decreased by 6% when the phenol concentration was increased up to 7 g/L. Moreover, high degree of phenol biodegradation (from 10% to 38%) was achieved when phenol concentration was increased in the range from 1 to 7 g/L. The enzymatic membrane was also tested using coke wastewater. It was reported that the rate of filtration did not change over 18 h in the filtration process. The degree of phenol biodegradation increased from 36 to 57% during the first 3 h and then decreased and attained stability at 40% after 7 h. Deterioration in the enzymatic properties of the membrane was explained by the destructive influence of coke wastewater on the immobilized enzyme complex [29].

4.2. Chemically Immobilization on Polymeric Membranes

4.2.1. Covalent Attachment

Gupta et al. [30] have immobilized Lipase on polyvinyl alcohol photo modified polysulfone (PS-PVA) membranes. The maximum loading capacity for PS-PVA membranes was 1.48 mg/cm^2 . It was observed that there

was a direct correlation between the amount of lipase, which can be immobilized on the membrane, and the PVA content in the PS–PVA membrane. The hydrolytic performance of both the lipase immobilized PS (lipase-PS) and lipase immobilized PS–PVA–glu (lipase-PS–PVA–glu) membranes were determined against olive oil and the free fatty acid (FFA %) and acid value (AV) for PS–PVA–glu, which were determined by titrimetric analysis, were found to be 1.53 and 3.04, respectively. The K_m and V_{max} values were found to be 105 mM and 0.9 mM/min for lipase-PS–PVA–glu and 153.8 mM and 0.51 mM/min for lipase-PS. Lipase-PS–PVA–glu membranes were found to be more stable than lipase-PS membranes. It was observed that after five cycles of use there was only 10.7% decrease in reusability of Lipase-PS–PVA–glu membranes whereas there was 33.3% decrease in reusability of Lipase-PS membranes. The reaction mechanism with PVA and glutaraldehyde is presented in Figure 7.

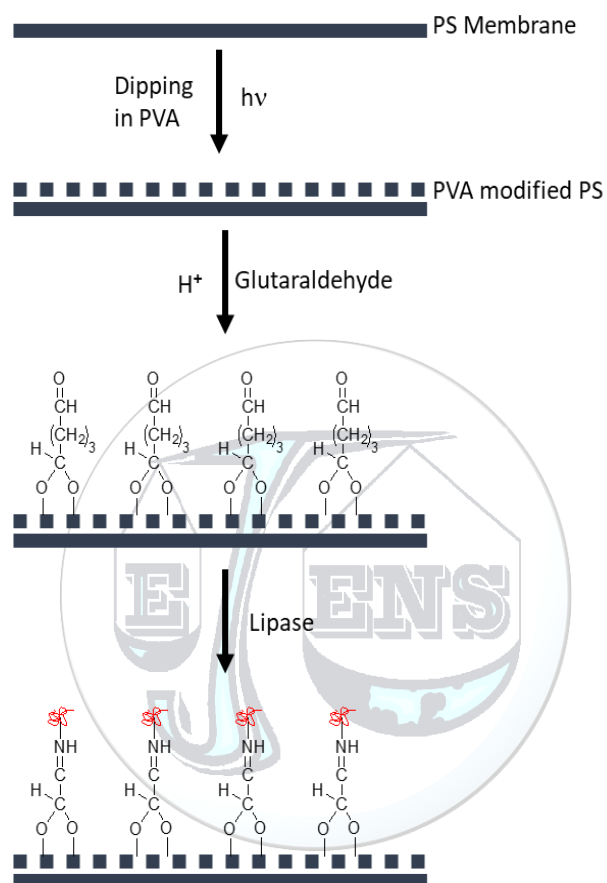

Figure 7. Reaction mechanism for immobilization of lipase on PS–PVA using glutaraldehyde [30].

It was reported that the amount of PVA on PS increases when dipping time increases and the efficiency of immobilization depends on the PVA content. Maximum amount of saturation, which was 2%, was observed to occur in 30 min. It was also observed that both for unmodified PS and PS–PVA membranes, glutaraldehyde concentration affects immobilization concentration which was found to be 2% for 30 min dipping time. It is expected that for other PS–PVA membranes it would be very similar. In this study, membrane surfaces were modified via photo-irradiation technique which was verified via FTIR, contact angle and pure water permeability measurements. It was observed that the longer the period the membranes were dipped in PVA solution the more PVA content was on the membranes [30].

The XRD and SEM results showed that lipase was successfully immobilized on the membranes. The change in the amount of immobilization was as follows: PS–PVA–glu[PS–glu[PS–PVA]. Covalent binding of glutaraldehyde in PS–PVA–glu membrane provided better immobilization efficiency than adsorption. As the amount of lipase on PS–PVA–glu membrane was more than that on the PS the total hydrolytic activity of lipase was found to be higher for PS–PVA–glu membranes. Among the factors of the hydrolytic reaction that influenced the hydrolytic activity pH, temperature and substrate concentration were investigated. Maximum hydrolytic activity was achieved at pH 8 and at 37 °C and at a concentration of 150 mM. As the acid values obtained via the titrimetric and GC methods indicate, the amount of free fatty acid (FFA) liberated by PS–PVA immobilized

membrane was more than that liberated by PS. The data obtained fit the two linear equations: Lineweaver–Burk and Hanes plot. When compared with PS membranes, higher hydrolytic reaction rate (V_{max}) was achieved with PS–PVA–glu membrane and the lower K_m values obtained with Lipase–PS–PVA–glu membrane compared to that obtained with lipase–PS membrane indicates the greater affinity to olive oil. Upon investigating the reusability feature, it was found that Lipase–PS–PVA–glu was –lipase membrane had better stability [30].

Gulec et al. [31] investigated how surface characteristics, chemical and physical structure of the CA membrane surfaces affected the immobilization yield and the enzyme activity of unmodified and plasma modified cellulose acetate (CA) membranes affected efficiency of immobilization of –galactosidases obtained from *Kluyveromyces lactic* (KLG), which is an essential enzyme in food industry, and its galacto-oligosaccharide (GOS). Surfaces of CA membranes were modified via low pressure plasma treatments involving oxygen plasma activation, plasma polymerization (PlsP) of ethylenediamine (EDA) and PlsP of 2-mercaptoethanol. Through plasma polymerization the NH_2 and SH groups from EDA and 2-mercaptoethanol precursors could be incorporated onto the surface of CA membranes. Moreover, PEI could successfully be used to coat enzyme layers on EDA modified CA membrane surface upon plasma polymerization of the surface.

KLG enzyme was immobilized on unmodified and oxygen plasma treated membranes via physical binding. It was observed that CA membranes modified via oxygen plasma activation had higher hydrophobicity and immobilization efficiency increased by a factor of 42%. The enzyme, KGL, was covalently immobilized on CA membranes via amino groups created by PlsP of EDA. Activating the membrane via plasma at 60 W plasma power for 15 min. increased the amount of enzyme immobilized by 3.5-fold. When the amount of amino groups were enriched via polyethyleneimine (PEI) addition this 3.5-fold increase was observed to be 4.5-fold. Probably due to the adverse effect of the active amino groups although enzyme loading efficiency (65–83%) was high the enzyme activity and GOS yield dramatically decreased (11–12%). It was observed that CA membrane surfaces modified with thiol groups created by PlsP of 2-mercaptoethanol provided more effective immobilization of KLG enzyme with immobilization yield of 70% as well as high enzyme activity of 46%. Enzyme immobilized CA membranes treated by PlsP could be successively used for 5–8 cycles at 25 °C and the enzymatic derivatives could retain 75–80% of their initial activities after the cycles. Low temperature plasma is an important technique for modifying several polymeric membranes effectively [31].

It was observed that the techniques employed for immobilizing enzyme KLG had great impact on the apparent parameters of the enzyme-catalyzed reactions. The presence of KLG on membranes significantly changed the kinetics of GOS production. The GOS yield for separating monosaccharides from reaction mixture, selectively, was improved via PlsP of EDA modified CA membranes. High reactor productivity could be achieved via the combined system based on simultaneous production and separation with high enzyme loading. However, this system is still under development.

In a study by Hilal et al. [32] physical and chemical immobilization methods were used for immobilizing lipase enzyme on ultrafiltration membranes which were namely the regenerated cellulose (C030F) and polyethersulphone (PM30) membranes. In these methods, the lipase enzyme was either immobilized on the membrane via non-covalent method that is adsorption (Figure 8a), or it was incorporated in the membrane structure by filtration which was another noncovalent method or the enzyme was incorporated in the structure of the membrane via chemical method which was covalent attachment of lipase to the membrane (Figure 8b). These membranes were investigated for their catalytic properties in the reaction of butyloleate synthesis where the oleic acid was esterified with *n*-butanol in isooctane. The results showed that highly effective bio-catalytic membranes were prepared by inclusion of lipase in the wide pores of the supporting layer of the membrane. These lipase-immobilized bio-catalytic membranes provided oleic acid conversion at a degree of about 70–72% in a reaction time of 8 h. However, under the same experimental conditions, the bio-catalytic membranes obtained via adsorption or covalent immobilization of lipase could give substrate conversion of only 22–28 and 18–21%, respectively. The substrate conversion values were higher for membranes with filtration-immobilized lipase than those for membranes with adsorbed lipases since more lipase could be loaded on the membranes.

The study revealed that the distribution profile of the lipase in the membrane is an important factor in achieving effective enzyme utilization. Atomic Force Microscopy (AFM) was used for the profile imaging and the direct measurement of the interaction force between the lipase-coated tip and membrane surfaces. It was found that the direct measurement method is a useful and practical approach for choosing the right membranes as porous polymeric support for immobilizing lipase via adsorption [32].

The data on mass and area reaction rates indicate that at high enzyme loadings achieved in the filtration technique essential mass transfer is limited. The catalytic activity achieved in enzyme immobilization by filtration in the sponge layer of the asymmetric membranes provided higher catalytic activity compared to that obtained with the enzyme immobilized on the active membrane layer. In other words, the distribution profile of the lipase in the membrane has significant role on the effectiveness of immobilized enzyme. In a wide range of concentration, such

as 0.034–0.68 g protein/m², for enzyme loading a very small change of 63–72 and 43–48%, was achieved in the substrate conversion degree via the membranes with lipase immobilized in sponge or in active PM30 membrane layers, respectively. This indicates that not all the enzyme in the membrane is involved in the reaction. Hence, excessive loading of the enzyme in the membrane would not necessarily be beneficial.

C030F membrane on which the enzyme was adsorbed were more active in esterification reaction than the membrane on which the enzyme was covalently immobilized (Figure 8b). This may be due to conformational changes in the tertiary structure of the enzyme during its covalent immobilization on the membrane leading to some loss in the activity of the enzyme. In situations when a HMD spacer exists between the surface of the membrane and the chemically bound enzyme, negative effect of covalent immobilization decreases while the reaction rate of esterification increases.

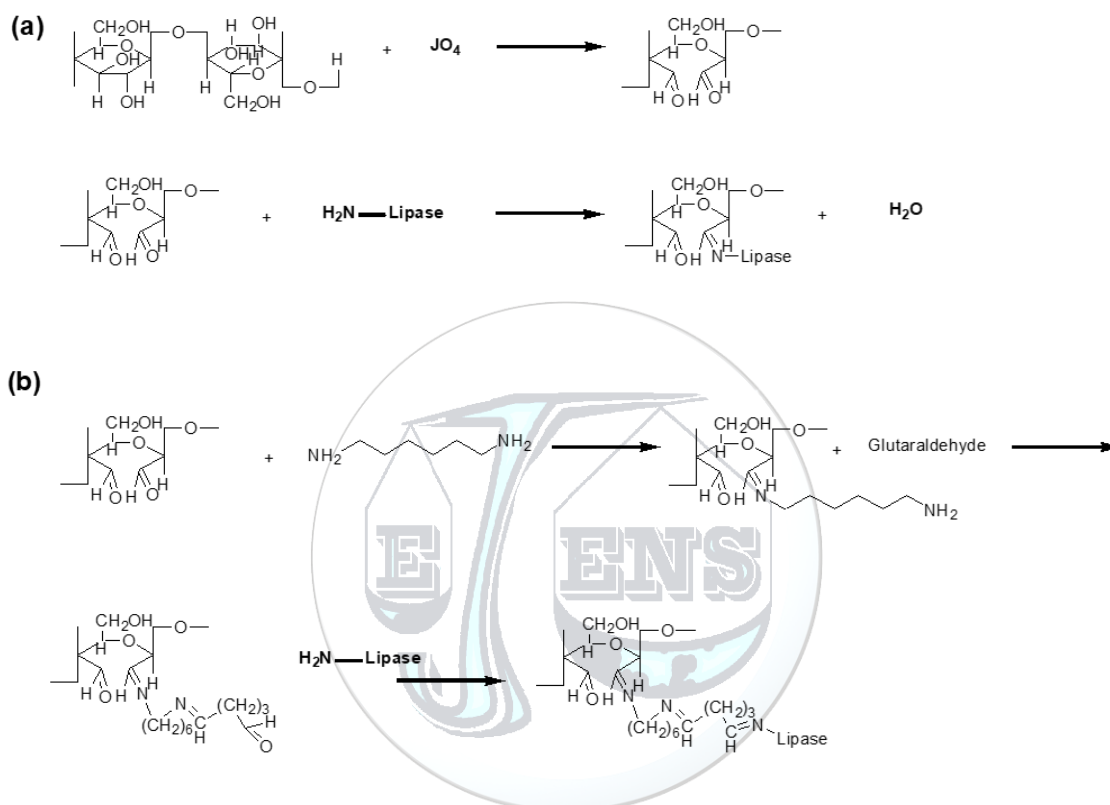

Figure 8. Schematic presentation of chemical binding of the enzyme lipase on the cellulose C030F membrane without (a) and with (b) a HMD spacer [32].

Vitola et al. [33] investigated the catalytic performance of a mutant, namely, SsoPoxW263F of the thermophilic Phosphotriesterase-like lactonase (PLL) isolated from *Sulfolobus solfataricus* (SsoPox). Lactonase was both introduced on free and immobilized membrane systems by using pesticide paraoxon as substrate. Bio-catalytic membrane systems which were obtained by immobilizing the single mutant on/into hydrophilic (Nonstandard grade Polyethersulphone, NSG-PES) and hydrophobic (Polyvinylidene fluoride, PVDF) membranes, could be used in the liquid and in the vapor phase for decontamination of water and air, respectively. Stability of the developed systems was determined by investigating the vapor and water permeability, catalytic activity of the free and immobilized enzyme as well as enzyme stability of the membranes for a period of more than 5 months. The results showed that the free mutant showed a higher performance up to 30 days, but after two months' period it lost its activity completely. However, although the bio-catalytic membranes lost their activity in the first days almost no instability in a period more than 5 months. For instance, when the mutant was immobilized on/into NSG-PES, the residual specific activity was about 54% and when it was immobilized on/into PVDF the residual specific activity was about 5%. The residual specific activity could be enhanced by changing the amount of mutant immobilized on the PVDF membrane. A trade off was found between the amount of immobilized enzyme and the catalytic performance. While the residual specific activity could be improved for both bio-catalytic membranes at least 5 months, the free system almost lost all its activity after two months. On the other hand, both bio-catalytic

membranes provided the same results in terms of vapor flux when water vapor was fed to them. This result may render this application the choice of preference in vapor phase decontamination applications [33].

Water and vapor permeance and flux through the native NSG-PES and functionalized NSG-PES-GA-SsoPox membranes and the relationship between these parameters and the pore size measurements before and after enzyme immobilization were measured. There was no considerable change in pore size, membrane wettability, water permeance and vapor flux after membrane biofunctionalization. Hence, it can be said that biofunctionalization process do not change the membrane properties [33].

4.2.2. Cross-linking

Atia et al. [21] investigated application of immobilized lipase enzyme on different radiation grafted polymeric films such as polypropylene (PP) and poly(tetrafluoroethylene-perfluoro-propyl vinyl ether) (PFA) using glutaraldehyde as cross linker. The polymeric membranes were modified by direct radiation grafting method and were grafted via Co60 γ -rays at a dose rate of 1.85 Gy/s. The modified membrane was activated by glutaraldehyde and lipase enzyme immobilized on the glutaraldehyde-activated membrane. The factors, which have pronounced effect on lipase activity such as graft yield, enzyme concentration, γ -irradiation, temperature, and pH, were systematically investigated. Activity of the immobilized lipase increased up to 178.5% upon grafting for PP, but it decreased when grafting was increased. This decrease in activity is attributed to the formation of multi bonds between lipase molecule and the PP-g-P(MAAc) membrane leading to increased AAc concentration. The immobilized lipase activity on PFA membrane increased with the percentage of grafting. Besides this increasing the amount of added protein resulted in a decrease in the activity of the retained enzyme. A study on the effect of γ -irradiation revealed that the free lipase lost about 50% of its relative activity when exposed to a dose of 2 Mrad and lost the rest of its activity upon exposure to a dose of about 5 Mrad. The results showed that irradiation at a dose of 5 Mrad caused no significant loss in the relative activity of the immobilized lipase. Immobilization of lipase on polymeric membranes had a shielding and stabilizing effect for the enzyme against radiation and the produced free radicals. The experimental results showed that the optimum temperature and pH were 40°C and 8.0, respectively, for free and immobilized lipase. The kinetic studies showed that the K_m value, which is a measure of the rate of reaction, decreased for immobilized lipase [21].

Gebreyohannes et al. [34] investigated the performance of an innovative magnetic responsive bio-catalytic membrane reactor (BMRSP) under various operational parameters. The effect of feed flow rate, temperature, feed concentration, and enzyme concentration were investigated via cross-linking of the pectinase enzyme (Figure 9).

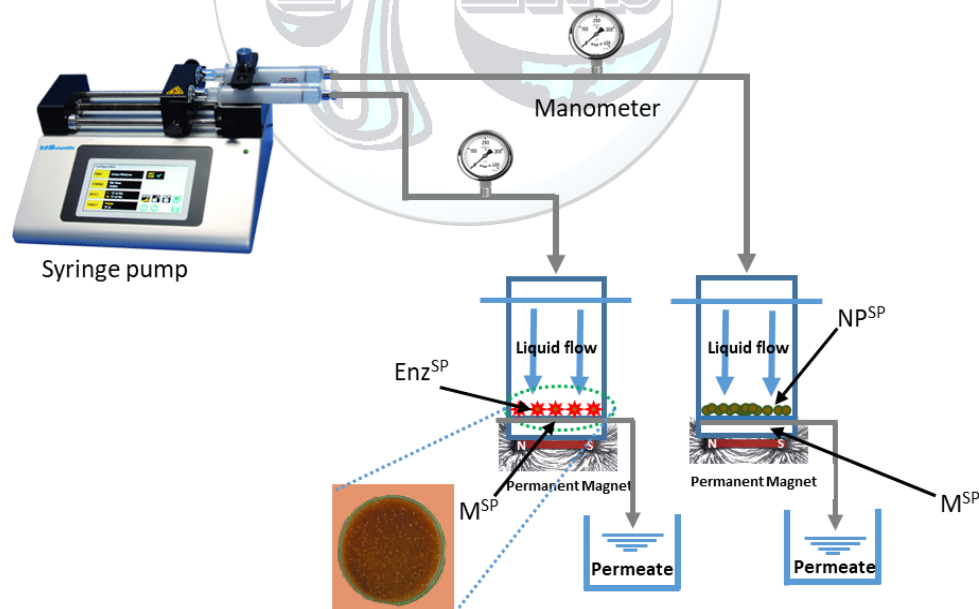

Figure 9. Schematic illustration of the filtration set-up consisting of a syringe pump with two heads, two syringes each having 100 mL capacities, dead end filtration cell containing dynamic layer of pectinase activated magnetic nanoparticles (EnzSP), parallel control filtration cell containing dynamic layer of neutral magnetic nanoparticles (NPSP) and two parallel permeate tanks and digital manometers [34].

It was observed that the feed flow rate affected the average degrees of conversion at 5, 15, 30 and 45 L/m² h as 28, 31, 28 and 34%, respectively. When the thermal stability of the BMRSP were tested in the temperature range between 25-40 °C, it was found 40 °C was the optimum temperature at which the enzyme pectinase provided the best efficiency. At 40 °C, the reaction rate was fast and accumulation of unreacted pectin was lower than that at 25 °C. At the lower temperature additional hydraulic resistance occurred and this induced a constant raise in the TMP.

Penicillin G acylase was immobilized on highly porous cellulose-based polymeric membrane in the presence of different ionic molecules/compounds which were used as ligand. The buffer flux at a pressure of 0.5 bars was 1,746 LMH (L m⁻² h⁻¹). Activity of the immobilized enzyme was found to be around 250 UApp in the presence of a ligand such as proline, tryptophan, casein acid hydrolysate, and brilliant green. Different ligands provided different percentage immobilization yield (IMY%) and percentage of activity retention (RTA%). For instance, while the IMY % for proline was found to be less IMY% (—58) and the RTA% (— 71) higher, the specific activity was observed to be 145 UApp g⁻¹. However, when the brilliant green was prepared via crosslinking it via glutaraldehyde, activity of the immobilized enzyme was found to be 82±2.7% after a using it for successive five cycles. On the other side, when free enzyme was compared with the enzyme immobilized on the brilliant green coupled membrane it was observed that at there was 2.4-fold increase in K_m value (47.4 mM) and they had similar optimum pH, which was 7.2, and temperature, which was 40°C. The results showed that the immobilized enzyme retained almost 50% of its activity even being used for 50 cycles and after 107 days. However, after the enzyme immobilization the buffer flux decreased by almost 50%.

However, although after 30 cycles buffer flux decreased by 38%, this decrease reached a steady state after 16 cycles. The flux pattern is of great importance as this would be an important parameter in assessing the operation life of the membrane that hosts the enzyme. Almost a 50% decrease was observed in the buffer flux after the enzyme was immobilized. This shows that immobilization procedure affects pore size of the membrane. The results for 30 cycles of operation were studied. Although the average buffer flux observed after the first 1-15 cycles of operation was 655±83 LMH, it was 545±15 LMH for 16-30 cycles of operation. The studies showed that the average sample flux for the first 1- 15 cycles was 436±94 LMH, but for 16 to 30 cycles it was 310±11 LMH. These results indicate that the change in the flux value becomes less at higher numbers of cycles of operation and at even higher values it approaches a steady state. After 30 cycles of operation, the buffer flux pattern decreases by almost 38%. This indicates that around 60% active flux of the membrane remains intact and this value can be interpreted as the membrane has good operation life. In this study, it was observed that Proline selectively adsorbs penicillin G acylase, but the stability is less. The results indicate that stability may be enhanced if the binding chemistry is improved. The significant activity retention of Penicillin G acylase immobilized on the brilliant green coupled membrane and its storage and operational stability besides the flux pattern rendered it successful. This technology would be of preference of choice in industrial applications if an enzyme obtained from the modified microbial strain is used in immobilization [34].

Present work primarily deals with an exhaustive investigation on the effect of -galactosidase (EC 3.2.1.23) immobilization on polymeric polyether sulfone, cellulose triacetate and thin film composite polyamide membrane to produce galacto-oligosaccharides from lactose. Fouling is one of the key issues that control any membrane separation process to obtain the desired product. Especially, this issue with membrane becomes multiplied after making any attachment of immobilization chemicals on its surface, i.e. in case of enzymatic membrane reactor. Present work thus aims to identify the insights of carbohydrate interactions with the membrane surface after immobilization and how far it controls the production of galacto-oligosaccharides in this membrane reactor. Figure 10 shows the schematic representation of the membrane module used in this study.

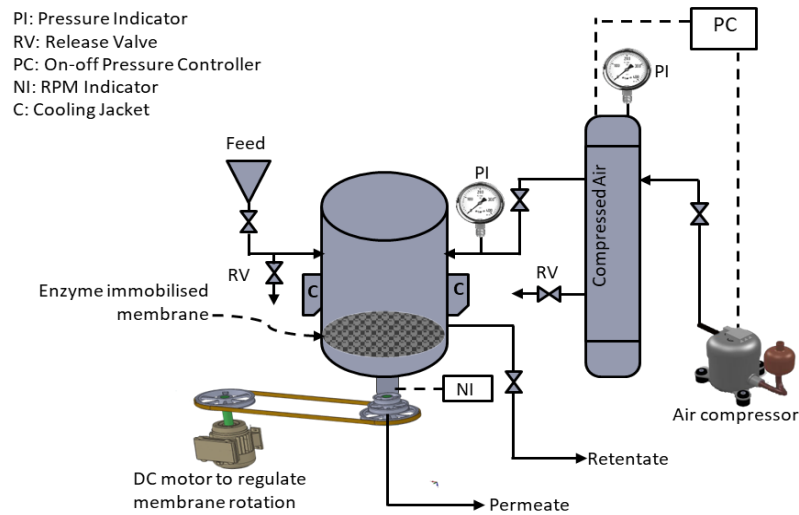

Figure 10. Schematic representation of the experimental setup.

Figure 11 shows the crosslinking of enzyme on polyamide NF membrane after immobilization.

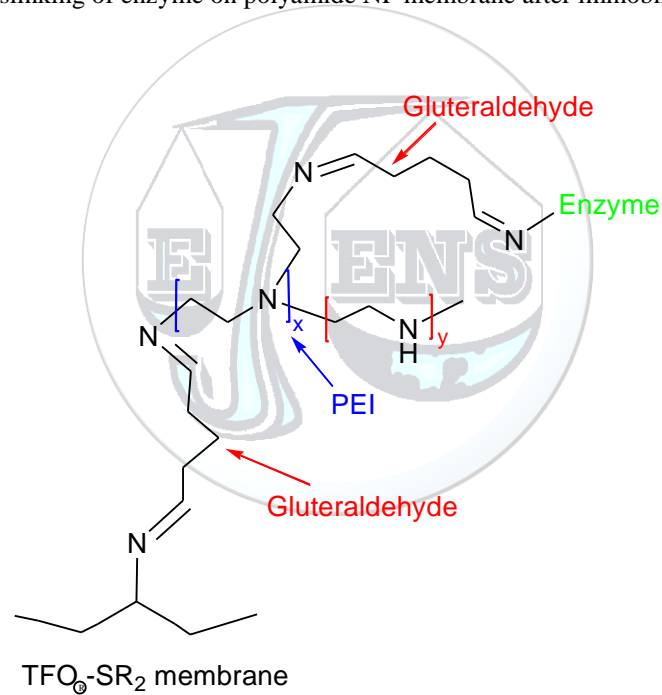

Figure 11. Immobilized TFC[®]-SR₂ membrane with β -galactosidase

Glu259 amino acid residue acts as a nucleophile for β -galactosidase (EC 3.2.1.23; Uniprot A/C Number: O31341) from *B. circulans*. This catalytically active amino acid residue forms a hydrogen bond with the galactosyl moiety leading to a formation of enzyme-galactosyl complex (Figure 12).

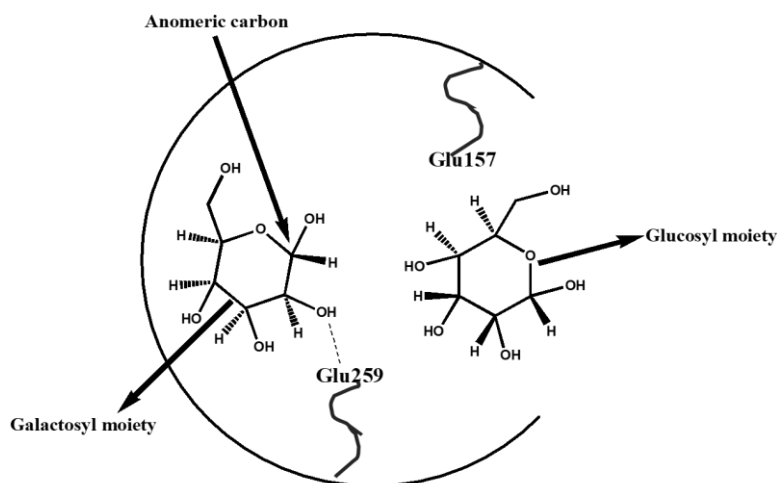

Figure 12. *Glu259 amino acid residue acts as a nucleophile for β -galactosidase*

Present study was an in-depth investigation on the reaction and separation of sugars with an enzyme immobilized membrane. Now from the observations it was seen that immobilization of enzyme on the polymeric membrane modifies the functional group presents on the surface and thus making some notable changes in the permeation characteristics of the membrane for carbohydrates. Especially immobilized CTA membrane shows more conversion compared to

the PES membrane, probably because of higher retention of lactose on the immobilized side. However, in any case the retention of monosaccharides was more with either PES or CTA, which is imparting an inhibitory effect on the enzymatic production of GOS. In comparison with the others, these immobilized NF membranes showed more convenient observations during GOS production. Although the requirement of high pressure with immobilized NF was one of the concerns, but in any way it shows good results with high separation for GOS and other sugars produced during the hydrolysis of lactose.

5. FUTURE PERSPECTIVE OF ENZYMIC MEMBRANE REACTOR

Enzyme immobilization confers distinct advantages in bio-catalysis which provide more consistent performance and eco-friendliness. Among these advantages can be named

- 1) possibility of increasing control over reaction by separating the catalyst from the reagents and products,
- 2) reuse of the catalyst,
- 3) minimization or elimination of contamination of the products by the enzyme as well as of undesirable side reactions,
- 4) miniaturization, which brings along the advantage of improving the kinetic performance of enzymes, render these devices particularly preferable in analytical and biotechnological applications.

Although there are many different methods, materials, and enzymes which can provide this end, bio-micro reactors can be categorized under four main types:

- 1) **Surface-immobilized enzymes:** In this type, enzymes are bound to the surface of a pre-constituted micro reactor for instance by activating the inner channels of a capillary and then they are exposed to the reagent flow;
- 2) **Enzyme activated beads:** This type of bioreactors is prepared by functionalizing porous beads with enzymes and then filing them into the chamber of a micro reactor;
- 3) **Enzyme-containing monoliths:** meso- or macro porous monoliths are either previously coated with a resistant layer or are directly prepared in a microchannel. Then they are functionalized with enzymes; and
- 4) **Membranes:** In this type, the bioreactor is the selective ultrafiltration membrane onto which enzymes are immobilized [35].

6. CONCLUSIONS

As is presented in this review, enzymatic membrane reactors represent a very interesting and diverse area of research. They offer many different solutions for chemical and biochemical problems, with the underlying goal to enhance the selectivity and yield of complex reactions and separation. In particular, the development of selective

and reversible enzyme immobilization may allow for more versatile systems permitting potential reuse of the unit after the loss of enzymatic activity in enzymatic membrane reactors.

REFERENCES

- [1] J.G.S. Marcano, T.T. Tsotsis, *Catalytic membranes and membrane reactors*, Online ISBN:9783527601981, Wiley-VCH Verlag GmbH, 2004.
- [2] A. Asatekin, S. Kang, M. Elimelech, A.M. Mayes, Anti-fouling ultrafiltration membranes containing polyacrylonitrile-graft-poly(ethylene oxide) comb copolymer additives, *J Membr. Sci.* 298 (2007) 136–146.
- [3] T. Uragami, S. Chakraborty, V. Piemonte, L.D. Paola, *Biocatalytic membrane reactors: principles, preparation and biotechnological, pharmaceutical and medical applications*, Handbook of membrane reactors, 2013.
- [4] A. Al-Amoudi, R.W. Lovitt, Fouling strategies and the cleaning system of NF membranes and factors affecting cleaning efficiency, *J. Membr. Sci.* 303 (2007) 4–28.
- [5] S. Shirazi, C. Lin, D. Chen, Inorganic fouling of pressure-driven membrane processes – a critical review, *Desalination*. 250 (2010) 236–248.
- [6] N. Pena, S. Gallego, F. del Vigo, S.P. Chesters, Evaluating impact of fouling on reverse osmosis membranes performance, *Desalin. Water Treat. iFirst* (2012) 1–11.
- [7] F. Afani au [Gabriele Iorio, G. Greco Jr., M. Cantarella, M.H. Remy, V. Scardi, Kinetic behaviour of immobilized enzyme membrane reactors, *Chem. Eng. Sci.* 34(10) (1979) 1213-1219.
- [8] J. Agustian, A.H. Kamaruddin, S. Bhatia, Enzymatic membrane reactors: the determining factors in two separate phase operations, *J. Chem. Technol. Biotechnol.* 86 (2011) 1032–1048.
- [9] F. Gao, X. Tang, H. Yi, S. Zhao, C. Li, J. Li, Y. Shi, X. Meng, A Review on selective catalytic reduction of NO_x by NH₃ over Mn-based catalysts at low temperatures: Catalysts, mechanisms, kinetics and DFT calculations, *Catalysts* 7 (2017) 199-231.
- [10] P. Mäntsälä, J. Niemi, *Enzymes: The biological catalysts of life. Physiology and Maintenance – Vol. II – Enzymes: The Biological Catalysts of Life.*
- [11] E. Piacentini, M. Yan, L. Giorno. Development of enzyme-loaded PVA microspheres by membrane emulsification, *J. Membr. Sci.* 524 (2017) 79-86.
- [12] R.A. Sheldon, S. van Pelt. Enzyme immobilisation in biocatalysis: why, what and how. *Chem. Soc. Rev.* 42 (2013) 6223-6235.
- [13] S.L. Matson, J.A. Quinn, *Membrane reactors*. In: Ho W.S.W., Sirkar K.K. (eds) *Membrane Handbook*. Springer, Boston, MA, 1992.
- [14] K.K. Sirkar, V. Purushottam, A. Shanbhag, S. Kovvali, Membrane in a reactor: A functional perspective, *Ind. Eng. Chem. Res.* 38(10) (1999) 3715–3737.
- [15] M. Amounas, C. Innocent, S. Cosnier, P. Seta, A membrane based reactor with an enzyme immobilized by an avidin–biotin molecular recognition in a polymer matrix. *J. Membr. Sci.* 176 (2000) 169-176.
- [16] J.N. Talbert, J.M. Goddard, Enzymes on material surfaces, *Colloids Surf. B: Biointerfaces* 93 (2012) 8–19.
- [17] C. Mateo, J.M. Palomo, G. Fernandez-Lorente, J.M. Guisan, R. Fernandez Lafuente, Improvement of enzyme activity, stability and selectivity via immobilization techniques, *Enzym. Microb. Technol.* 40 (2007) 1451–1463.
- [18] P. Wang, H.F. Jia, G.Y. Zhu, Catalytic behaviours of enzymes attached to nanoparticles: the effect of particle mobility, *Biotechnol. Bioeng.* 84 (2003) 406–414.
- [19] S.A. Ansari, Q. Husain, Potential applications of enzymes immobilized on/in nano materials: a review, *Biotechnol. Adv.* 30 (2012) 512–523.
- [20] J. Lu, P.H. Toy, Organic polymer supports for synthesis and for reagent and catalyst immobilization, *Chem. Rev.* 109 (2009) 815–838.
- [21] K. S. Atia, Characterization and application of immobilized lipase enzyme on different radiation grafted polymeric films: Assessment of the immobilization process using spectroscopic analysis, *J Appl. Pol. Sci.* 90(1) (2003) 155-167.

- [22] N.R. Mohamad, N. H.C. Marzuki, N.A. Buang, F. Huyop, R.A. Wahab, An overview of technologies for immobilization of enzymes and surface analysis techniques for immobilized enzymes. *Biotechnol Biotechnol Equip.* 29(2) (2015) 205–220.
- [23] S. Datta, L.R. Christena, Y.R.S. Rajaram. Enzyme immobilization: an overview on techniques and support materials. *3 Biotech.* 3(1) (2013) 1–9.
- [24] B.M. Brena, F. Batista-Viera, Enzyme immobilization literature survey from methods in biotechnology: Immobilization of enzymes and cells, Second Edition Edited by: J. M. Guisan © Humana Press Inc. Totowa, NJ.
- [25] J. Fan, J. Luo, Y. Wan. Aquatic micro-pollutants removal with a biocatalytic membrane prepared by metal chelating affinity membrane chromatography. *Chem. Eng. J.* 327 (2017) 1011–1020.
- [26] M.F. Chaplin, C. Bucke. Enzyme technology. Edition, illustrated. Publisher, CUP Archive, 1990. ISBN, 0521348846, 9780521348843. Length, 264 pages.
- [27] L. Giorno, J. Zhang, E. Drioli, Study of mass transfer performance of naproxen acid and ester through a multiphase enzyme-loaded membrane system, *J. Membr. Sci.* 276(1-2) (2006) 59-67.
- [28] F. Xu, W.H. Wang, Y.J. Tan, M.L. Bruening, Facile trypsin immobilization in polymeric membranes for rapid, efficient protein digestion, *Anal. Chem.* 82 (2010) 10045–10051.
- [29] J. Bohdziewicz, Biodegradation of phenol by enzymes from *Pseudomonas* sp. immobilized onto ultrafiltration membranes, *Process Biochem.* 33(8) (1998) 811-818.
- [30] S. Gupta, Y. Kumar, K. Singh. A. Bhattacharya, Lipase immobilized on poly (vinyl alcohol) modified polysulfone membrane: application in hydrolytic activities for olive oil, *Polym. Bull.* 64 (2010)141–158.
- [31] H.A. Gülec, Immobilization of β -galactosidase from *Kluyveromyces lactis* onto polymeric membrane surfaces: Effect of surface characteristics, *Colloids and Surfaces B: Biointerfaces* 104 (2013) 83– 90.
- [32] N. Hilal, V. Kochkodan, R. Nigmatullin, V. Goncharuk, L. Al-Khatib, Lipase-immobilized biocatalytic membranes for enzymatic esterification: Comparison of various approaches to membrane preparation. *J. Membr. Sci.* 268 (2006) 198–207.
- [33] G. Vitola, R. Mazzei, E. Fontananova, E. Porzio, G. Manco, S.N. Gaeta, L.Giorno, Polymeric biocatalytic membranes with immobilized thermostable Phosphotriesterase, *J. Membr. Sci.* 516 (2016)144–151.
- [34] A.Y. Gebreyohannes, L. Giorno, I.F.J. Vankelecom, T. Verbiest, P. Aimar, Effect of operational parameters on the performance of a magnetic responsive biocatalytic membrane reactor, *Chem. Eng. J.* 308 (2017) 853-862.
- [35] E. Laurenti, A. dos Santos Vianna Jr. Enzymatic microreactors in biocatalysis: history, features, and future perspectives, *Biocatalysis.* 1 (2015) 148–165.