

SLIDING MODE CONTROL FOR A PERMANENT MAGNET SYNCHRONOUS MACHINE FED BY THREE LEVELS INVERTER USING A SINGULAR PERTURBATION DECOUPLING

Ahmed MASSOUM¹ Mohamed Karim FELLAH¹
Abdelkader MEROUFEL¹ Patrice WIRA²
Baghdad BELLABES¹

¹ICEPS Laboratory, Sidi Bel Abbes University. ALGERIA

²Mips-trop Laboratory, Haute Alsace University. Mulhouse Cedex FRANCE

E-Mail: ahmassoum@yahoo.fr

ABSTRACT

In this paper, we present the singular perturbation for decoupling a permanent magnet synchronous machine that deals with a separation of the variables in disjointed subset or two separate models: one having a slow dynamics, and the other a fast dynamics. The control speed and the Id current are carried out by sliding mode regulators. A qualitative analysis of the evolution of the principal variables describing the behavior of the global system (PMSM-Inverter (PWM) -Control) and its robustness is development by several tests of digital simulation

Keywords: PMSM, singular perturbation, three levels inverter (PWM), sliding mode controllers.

1. INTRODUCTION

The technique of the vectorial control allows comparing the PMSM to the D.C machine with separate excitation from the point of view couples. The flux vector must be concentrated on the D axis with the I_d current null [1]. However the exact knowledge of the rotoric flux position gives up a precision problem [2]. Thus, it is possible to control independently the speed and the forward current I_d . The traditional algorithms of control (PI or PID) prove to be insufficient where the requirements in performances are very severe. Several methods of control are proposed in the technical literature, among them, the sliding mode control. Its nonlinear algorithm give the robustness properties with respect to the

parametric variations and well adapts to the modeled systems [4,5]. To this end, we are interested in the application of sliding mode for the control of the PMSM decoupled by the singular perturbation technique. The work is composed by a PMSM modeling in the Park frame and an overview of the singular perturbation technique in order to decouple the machine model. Then, a brief outline on the sliding control and its application to the speed and the Id current control of the PMSM supplied with the three levels inverter. In the last step, a comment on the results obtained in simulation and a conclusion where we emphasize the interest and the contribution of this method of order.

Received Date : 07.01.2005

Accepted Date: 13.05.2005

2. THE NL MODEL OF THE PMSM

With the simplifying assumptions relating to the PMSM, the model of the machine expressed in the reference frame of Park, in the form of state is written [3, 5, 6].

$$\dot{x} = F(x) + \sum_{i=1}^m g_i(x) U_i \quad (1)$$

With

$$x = \begin{pmatrix} x_1 \\ x_2 \\ x_3 \end{pmatrix} = \begin{pmatrix} I_d \\ I_q \\ \Omega \end{pmatrix}; U_i = \begin{pmatrix} U_1 \\ U_2 \end{pmatrix} = \begin{pmatrix} U_d \\ U_q \end{pmatrix} \quad (2)$$

$$g_1 = \begin{pmatrix} \frac{1}{L_d} \\ 0 \\ 0 \end{pmatrix}; g_2 = \begin{pmatrix} 0 \\ \frac{1}{L_q} \\ 0 \end{pmatrix}$$

$$F(x) = \begin{pmatrix} f_1(x) \\ f_2(x) \\ f_3(x) \end{pmatrix} = \begin{pmatrix} \frac{-R}{L_d} x_1 + \frac{pL_q}{L_d} x_2 x_3 \\ \frac{-R}{L_q} x_2 - \frac{pL_d}{L_q} x_1 x_3 - \frac{p\Phi_f}{L_q} x_3 \\ \frac{-f}{J} x_3 + \frac{p(L_d - L_q)}{J} x_1 x_2 + \frac{p\Phi_f}{J} x_2 - \frac{C_r}{J} \end{pmatrix} \quad (3)$$

The variables to be controlled are current I_d and mechanical speed Ω

$$Y(x) = \begin{pmatrix} y_1(x) \\ y_2(x) \end{pmatrix} = \begin{pmatrix} h_1(x) \\ h_2(x) \end{pmatrix} = \begin{pmatrix} x_1 \\ x_2 \end{pmatrix} = \begin{pmatrix} I_d \\ \Omega \end{pmatrix} \quad (4)$$

3. SINGULAR PERTURBATIONS

The interest of this method relates especially the determination of composite form control. The global model is decoupled in a slow sub-model and a fast sub-model.

The singularly perturbed systems analyzed by this technique must have special form called standard. This form is written as follows [8,9,10]

$$\begin{aligned} \dot{x} &= f(x, z, u, t, \varepsilon) \\ \varepsilon \dot{z} &= g(x, z, u, t, \varepsilon) \\ y &= h(x, z) \end{aligned} \quad (5)$$

With

$$\begin{aligned} x(t_0) &= \xi(\varepsilon) \\ z(t_0) &= \eta(\varepsilon) \end{aligned}$$

The model is known as singularly disturbed because:

The introduction of a small parameter ε is considered as perturbation.

The particular value $\varepsilon=0$ introduces a singularity. Generally, this depends on the decomposition of the original system in two reduced dimensions subsystems.

By rearranging the state vector to decompose it into two sub-vectors, the following model is obtained:

$$\begin{aligned} \dot{x} &= f(x, u, t) \\ y &= h(x) \end{aligned} \quad (6)$$

With

$$x^T = [x_1^T, x_2^T]^T = [x_{1s}^T + x_{1f}^T, x_{2s}^T + x_{2f}^T]^T \quad (7)$$

$$x(0) = x_0$$

The first state sub-vector has a negligible fast part with respect to the slow part, therefore:

$$\begin{aligned} x_s^T &= x_{1s}^T = x_s^T \\ x_f^T &= 0 \end{aligned} \quad (8)$$

The second sub-vector has the negligible slow component with respect to the fast component, therefore:

$$\begin{aligned} x_2^T &= x_{2f}^T = x_f^T \\ x_{2s}^T &= 0 \end{aligned} \quad (9)$$

This leads to:

$$x^T = [x_s^T, x_f^T]^T \quad (10)$$

Let's take ε defined as being the ratio between the time-constants of fast variable and the slow variable:

$$\varepsilon = \frac{\tau_f}{\tau_s} \quad (11)$$

The model becomes:

$$\begin{aligned} \dot{x} &= f(x_s, x_f, u, t, \varepsilon) \\ \varepsilon \dot{z} &= g(x_s, x_f, u, t, \varepsilon) \\ y &= h(x_s, x_f) \end{aligned} \quad (12)$$

With

$$\begin{aligned} x_s(0) &= x_{s0} \\ x_f(0) &= x_{f0} \\ \varepsilon &= [0, 1] \end{aligned} \quad (13)$$

The slow model is found by supposing that

$$\begin{aligned} \varepsilon &= 0; \\ f_2(x_s, x_f, u, t, 0) &= 0 \end{aligned} \quad (14)$$

One will have:

$$\begin{aligned} \dot{x}_s &= F(x_s, u, t) \\ y &= H(x_s, u, t) \end{aligned} \quad (15)$$

For the fast model, one takes $\varepsilon \neq 0$:

$$\varepsilon \dot{x}_f = f_2(x_s, x_f, u, t, \varepsilon) \quad (16)$$

The fast reduced system is obtained by transforming the time scale T of the original system into a fast time scale τ , such as:

$$\tau = \frac{t - t_0}{\varepsilon} \quad (17)$$

4. SINGULAR PERTURBATIONS APPLIED TO PMSM

By considering that the variables I_{ds} and I_{qs} are fast and that ω_r is slow and choosing: $I_{ds} = I_{dsr}$;

$$I_{qs} = I_{qsr}; \quad \omega_r = \omega_{rl}$$

One will have [5,8,9,10]:

$$\frac{d\omega_{rl}}{dt} = \frac{p^2}{J} \phi_f I_{qsr} - \frac{p}{J} C_r - \frac{f}{J} \omega_{rl} \quad (18)$$

$$\begin{aligned} \varepsilon \frac{dI_{dsr}}{dt} &= -\varepsilon \frac{R_s}{L_d} I_{dsr} + \varepsilon \frac{L_q}{L_d} \omega_{rl} I_{qsr} + \frac{\varepsilon}{L_d} v_{ds} \\ \varepsilon \frac{dI_{qsr}}{dt} &= -\varepsilon \frac{R_s}{L_q} I_{qsr} - \varepsilon \frac{L_d}{L_q} \omega_{rl} I_{dsr} + \frac{\varepsilon}{L_q} v_{qs} \\ &\quad - \varepsilon \frac{\phi_f}{L_q} \omega_{rl} \end{aligned} \quad (19)$$

By rearranging the equations, one obtains:

- Slow model:

$$\frac{d\omega_{rs}}{dt} = \frac{p^2 \Phi_f}{J \left(\left(\frac{R_s}{L_d} \right)^2 + \omega_{rs} \right)^2} \left(\frac{R_s}{L_d L_q} v_{qss} \right) \quad (20)$$

$$-\frac{R_s \Phi_f}{L_d L_q} \omega_{rs} - \frac{1}{L_d} \omega_{rl} v_{qss} - \frac{p}{J} C_r - \frac{f}{J} \omega_{rs}$$

$$y_s = \omega_{rs}$$

With $\omega_{rs}(0) = 0$

- Fast model:

$$\frac{dI_{dsf}}{d\tau} = -\varepsilon \frac{R_s}{L_d} I_{dsf} + \varepsilon \frac{L_q}{L_d} \omega_{rf} I_{qsf} + \frac{\varepsilon}{L_d} v_{dsf} \quad (21)$$

$$\begin{aligned} \frac{dI_{qsf}}{d\tau} &= -\varepsilon \frac{R_s}{L_q} I_{qsf} - \varepsilon \frac{L_d}{L_q} \omega_{rs} I_{dsf} + \frac{\varepsilon}{L_q} v_{qsf} \\ &\quad - \varepsilon \frac{\phi_f}{L_q} \omega_{rs} \end{aligned} \quad (22)$$

$$y_f = I_{dsf}$$

With $I_{dsr}(0) = 0$, et $I_{qsr}(0) = 0$

$$U = \begin{bmatrix} v_{ds} \\ v_{qs} \end{bmatrix}^T = \begin{bmatrix} v_{dss} + v_{dsf} \\ v_{qss} + v_{qsf} \end{bmatrix}^T \quad (23)$$

A judicious choice of the controls such as:

$$\begin{aligned} v_{ds} &= v_{dsf} \quad \text{avec} \quad v_{dss} = 0 \\ v_{qs} &= v_{qss} \quad \text{avec} \quad v_{dsf} = 0 \end{aligned} \quad (24)$$

deals to the two decoupled models according to:

- The slow model:

$$\frac{d\omega_{rs}}{dt} = \frac{p^2 \phi_f}{J \left(\left(\frac{R_s}{L_d} \right)^2 + \omega_{rs} \right)^2} \left(\frac{R_s}{L_d L_q} v_{qss} \right) \quad (25)$$

$$-\frac{R_s \phi_f}{L_d L_q} \omega_{rs} - \frac{p}{J} C_r - \frac{f}{J} \omega_{rs}$$

$$y_s = \omega_{rs}$$

With $\omega_{rs}(0) = 0$

- Fast model:

$$\frac{dI_{dsf}}{d\tau} = -\varepsilon \frac{R_s}{L_d} I_{dsf} + \frac{\varepsilon}{L_d} v_{dsf}$$

$$\frac{dI_{qsf}}{d\tau} = -\varepsilon \frac{R_s}{L_q} I_{qsf} \quad (26)$$

$$y_f = I_{dsf}$$

With $I_{dsf}(0) = 0$

5. SLIDING MODE CONTROL

The sliding mode control algorithm design is to determine three different stages as follow [2,3,4]:

5.1 Commutation Surface

J. Slotine proposes a form of general equation to determine the sliding surface [3,4].

$$S(x) = \left(\frac{d}{dt} + \lambda \right)^{r-1} e \tag{27}$$

$e = x_d - x$: variation; λ : positive coefficient ;
 r : relative degree ; x_d : desired value.

5.2 Convergence Condition

The convergence condition is defined by the equation of Lyapunov [3,4].

$$S(x) \cdot \dot{S}(x) < 0 \tag{28}$$

5.3 Control Calculation

The control algorithm includes two terms, the first for the exact linearization, the second discontinuous one for the system stability [3,4].

$$u_c = u_{eq} + u_n \tag{29}$$

- u_{eq} is calculated starting from the expression

$$\dot{S}(x) = 0 \tag{30}$$

- u_n is given to guarantee the attractivity of the variable to be controlled towards the commutation surface.

The simplest equation is the form of relay:

$$u_n = k \operatorname{sgn} S(x) \quad ; k > 0 \tag{31}$$

k : high can cause the ‘chattering’ phenomenon.

5.4 The ‘CHATTERING’ Phenomenon elimination

The high frequency oscillation phenomenon can be reduced by replacing the function ‘sgn’ by a saturation function [3,4].

$$u_n = \begin{cases} \frac{k}{\varepsilon} S(x) & \text{si } |S(x)| < \varepsilon \\ k \operatorname{sgn}(S(x)) & \text{si } |S(x)| > \varepsilon \end{cases} \quad \varepsilon > 0 \tag{32}$$

6. THE SLIDING MODE APPLICATION

6.1. Basic structure of the sliding mode regulator

By using the principle of the flux orientation and by neglecting the time-constant of the converter, we can represent the model of the PMSM in the reference frame d-q in two independent subsets [2,3,4 ,6]:

- Control according to the d axis and q axis as shown in figures 1 and 2:

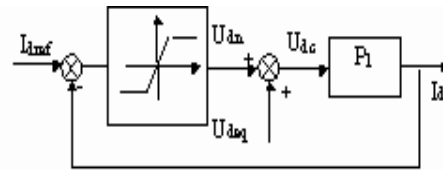

Figure 1. d axis control

- Control according to q axis

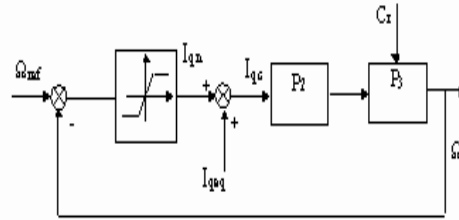

Figure 2. q axis control

6.2 Regulator synthesis

6.2.1 Surface choice

We choose the sliding surface according to the relation of Slotine and the output relative degree [2,3,4].

$$S_1(I_d) = I_{dref} - I_d \tag{33}$$

$$S_2(I_q) = I_{qref} - I_q$$

$$S_3(\Omega_r) = \Omega_{ref} - \Omega_r$$

For the cascade control, we distribute the surface control $S_3(\Omega_r)$ between speed and the component

I_q .

6.2.2 Control calculation

a. SMC relating to the d axis

$$\dot{S}_1(I_d)=0 \Rightarrow u_{deq}=\frac{1}{g_1}(\dot{I}_{dref}-f)$$

$$\dot{S}_1(I_d).S_1(I_d)<0 \Rightarrow u_{dn}=\begin{cases} \frac{k_d}{\varepsilon_d}S_1(I_d) & \text{si } |S_1(I_d)| \leq \varepsilon_d \\ k_d \text{sgn}S_1(I_d) & \text{si } |S_1(I_d)| > \varepsilon_d \end{cases} \quad (34)$$

finally the control law relating to the d axis is written as:

$$u_{dc}=u_{deq}+u_{dn}=\frac{1}{g_1}(\dot{I}_{dref}-f_1)+k_d \text{sgn}S_1(I_d) \quad (35)$$

b. SMC relating to the q axis

SMC relating to speed

$$\dot{S}_3(\Omega_r).S_3(\Omega_r)<0 \Rightarrow I_{qn}=\begin{cases} \frac{k_\Omega}{\varepsilon_\Omega}S_3(\Omega_r) & \text{si } |S_3(\Omega_r)| \leq \varepsilon_\Omega \\ k_\Omega \text{sgn}S_3(\Omega_r) & \text{si } |S_3(\Omega_r)| > \varepsilon_\Omega \end{cases}$$

$$\dot{S}_3(\Omega_r)=0 \Rightarrow I_{qref}=\frac{1}{g_3}(\dot{\Omega}_{ref}-f_3)$$

$$g_3=p\frac{(L_d-L_q)I_q}{J}+p\frac{\phi_f}{J} \quad (36)$$

6.2.3 Stability factor determination

The functions coefficients 'sgn(s)' must be quite selected to ensure the stability of the system and to satisfy the sliding mode conditions[3,4].

$$k_d < -\max_{I_d, I_q, \omega} |RI_d - L_q \omega I_q|$$

$$k_q < -\max_{I_d, I_q, \omega} |RI_q + L_d \omega I_d + \omega \phi_f| \quad (37)$$

$$k_\Omega < -\max_{\Omega, C_r} \left| \frac{C_r + f\Omega_r}{p\phi_f} \right|$$

6.3 Load torque estimate

The load torque is hardly measurable; which obliges us to use its estimate in the control expression I_{qc} . The method suggested by lePioufle permits to estimate, in real time, the load torque[11]. Figure3 illustrates the estimator principle.

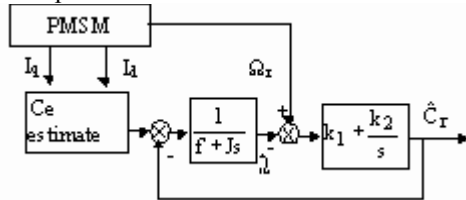

Figure 3. Load torque Estimator

The error between measured speed and estimated speed is presented as PI regulator input whose output is:

$$\tilde{C}_r = \frac{1 + \frac{k_1}{k_2}s}{1 + \frac{k_1}{k_2}s + \frac{1}{k_2}s^2} C_r \quad (38)$$

k_1 and k_2 are determined by the poles placement method.

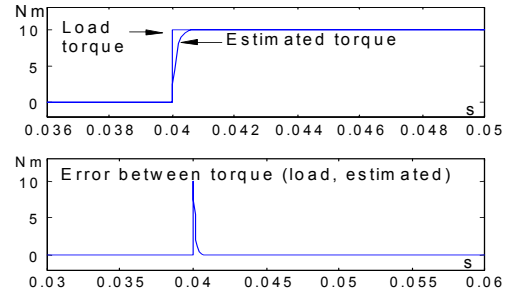

Figure 4. Estimator Response Characteristic

The estimated torque follows with a good precision the load variation in static mode while in dynamic mode it presents a light shift due to the estimator reaction as shown in figure 4.

7. THREE LEVELS INVERTER MODELISATION

The three levels tension inverter contains twelve pairs transistor-diodes permitting to generate amplitude tension levels of $U_1, 0, -U_2$. It is generally controlled by the PWM. The simple tension of each phase is entirely defined by the state of the four switches (transistors) constituting each arm. The median diodes of each arm permits to have level zero of the inverter output voltage. Only three sequences of operation are retained. Each arm of the inverter is modeled by a perfect switch with three positions (-1, 0, 1) as it is illustrated in figure 5. The three-phase simple tensions provided by the inverter are determined by the relation [1]:

$$[V] = \frac{U}{6} [C][F]$$

with

$$(V_{an} \ V_{bn} \ V_{cn})^T = [V]$$

$$(F_1 \ F_2 \ F_3)^T = [F]; \quad [C] = \begin{pmatrix} 2 & -1 & -1 \\ -1 & 2 & -1 \\ -1 & -1 & 2 \end{pmatrix} \quad (39)$$

$$F_i = S_{i1}S_{i2} - S_{i3}S_{i4}; \quad (i=1, 2, 3)$$

S_{ij} : Logic signals of arm i position column j
 F_i : Logic functions

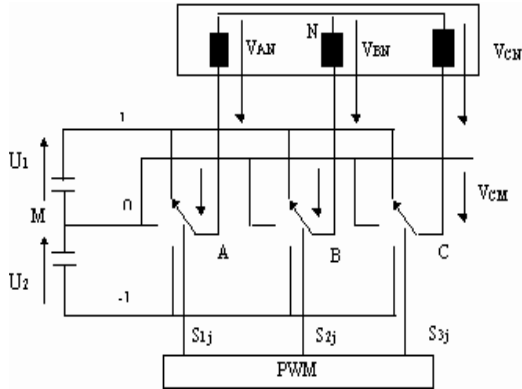

Figure 5. Multilevel Inverter diagram

8. SIMULATION

The decoupling based on the singular perturbations of the PMSM supplied with a MLI tension inverter and the sliding mode control, in figure 6, is tested by digital simulation.

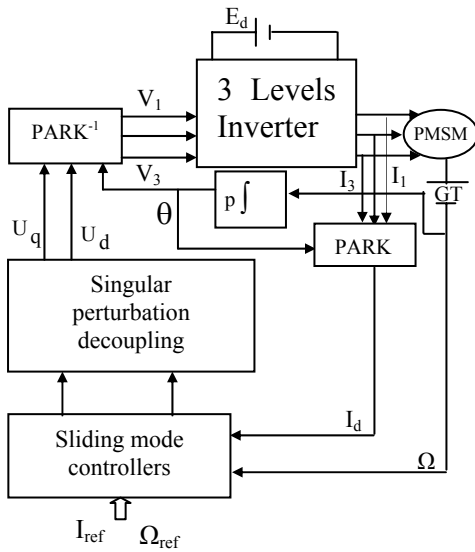

Figure 6. Sliding mode control diagram for PMSM using singular perturbation decoupling

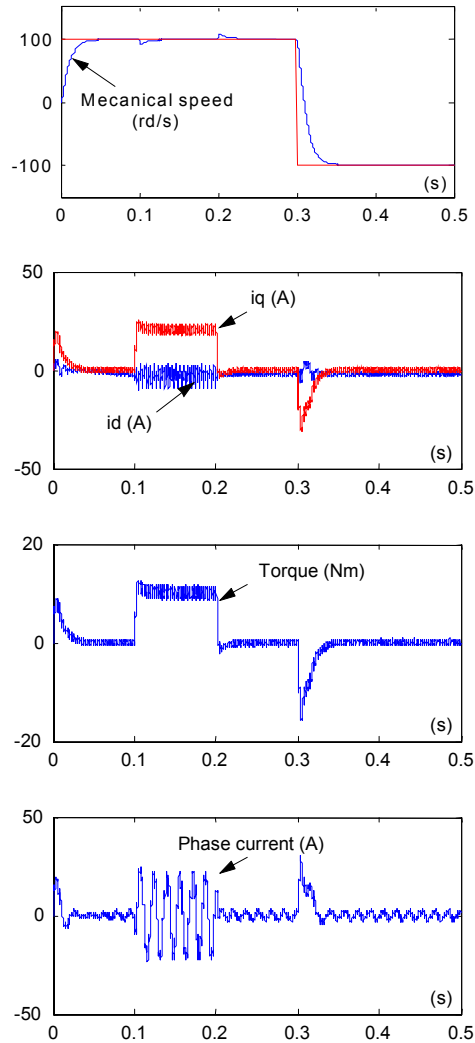

Figure 7. PMSM response to speed of 100rd/s followed by the load application (0.1s with 0.2s) and of an inversion speed - 100rd/s to 3s

9. CONCLUSION

We presented in this paper the performances the sliding mode control for the two different decoupling techniques of PMSM and associated a PWM tension inverter. The results obtained in figure 7 show the applicability of these control techniques in the electric drives field. The objectives of continuation and rejection of disturbance are acceptable. Decoupling is maintained even in the case of the load variations. The combination of the decoupling based on the singular perturbations and the sliding mode control has provided a stable

system with satisfactory performances as well to loadless system or during the load variation.

Machine parameters :

$L_d=1.4\text{mH}$ $L_q=2.8\text{mH}$ $\phi_f=0.12\text{wbP}=4;$
 $J=1.110^{-3}\text{kgm}^2;$ $f=1.410^{-3}\text{Nm/rds}^{-1};$ $C_e=8.5\text{Nm}$
 $R=0.6\Omega;$ $I_{qn}=20\text{A}$ $\Omega_n=230\text{rd/s}$

REFERENCES

- [1] B.K.Bose., *Power electronics*, Prentice Hall, New York, 1986.
- [2] B.Le Pioufle, G.Georgiou, I.P. Louis., "Application of NL control for the speed regulation or position of the autopilot synchronous machine", *physical Review applied*, pp. 517-527, 1990.
- [3] E. Bouhasoun, M. O. Mahmoudi, S.Boucherit., "Commande par mode de glissement d'une machine synchrone à aimants permanents avec pilotage vectoriel", *proceeding ICEL' 1998*, pp. 11-16, Oct 1998.
- [4] J. J. Slotine., *Applied non linear control*, Englewood Cliffs NJ. Tice Hall, 1991
- [5] P. Pillay, R. Krishnan., "Modelling simulation and analysis of permanent synchronous motor drives", *IEEE Trans On Ind*, Vol: 25, No: 2, pp. 265-273, March/April 1989.
- [6] P. Pillay, R. Krishnan., "Modelling of permanent motor drives", *IEEE Trans On Elect*, Vol: 35, No:4, pp265- 273, Nov 1988
- [7] B.Le Pioufle., "Comparison of speed not linear control strategies for the servomotor", *electric Machines and power systems*, pp. 151-169, 1993
- [8] PEDDAPULLAIAH SANNUTI., "Multiple Time-Scale Decomposition in Cheap Control Problems-Singular Control", *IEEE Transactions one Automatic Control, flight.Ac-30*, No: 7, July 1985
- [9] T.Song, MF Rahman, KW Lim, MA Rahman., "A Singular Disturbances Approach to Sensorless Permanent Control Magnet Synchronous Motor Drive", *IEEE Transactions one Energy Conversion*, vol.14, No: 4, dec1999.
- [10] P. SANNUTI., "One the Controllability of Singularly Perturbed Systems", *IEEE Transactions one Automatic Control*, vol. ac-22, No:4, August 1977.