

THIRD GENERATION CURRENT CONVEYOR BASED CURRENT-MODE FIRST ORDER ALL-PASS FILTER AND QUADRATURE OSCILLATOR

Mahmut Ün¹ Firat KAÇAR²

umahmut@beykent.edu.tr

fkacar@istanbul.edu.tr

¹Elect-Communication Eng. Dept, Faculty of Eng.-Arch., Beykent University Ayazaga, Sisli, Istanbul, TURKEY

²Electrical-Electronics Eng. Dept. Faculty of Engineering, Istanbul University, 34320,Avclar, Istanbul, TURKEY

ABSTRACT

A novel current-mode first order all-pass filter configuration is proposed. The proposed circuit uses a third generation current conveyor (CCIII), resistors and a capacitor. Since the output of the filter exhibits low output impedance the synthesized filter can be cascaded without additional buffers. To demonstrate the performance of the proposed filter a new current-mode quadrature oscillator is introduced as an application example. For non-ideal CCIII all-pass filter condition is derived and oscillation condition and frequency of the quadrature oscillator circuit are also presented. The theoretical results are verified with PSPICE simulations using CMOS realization of the CCIII.

Key words: All-pass filter, Current conveyor, Current-mode circuit, Oscillator.

1. INTRODUCTION

Current-mode circuits have been receiving considerable attention due to their potential advantages such as inherently wide bandwidth and low power consumption [1-3]. The active devices that have been used for the realization of current-mode circuits include current conveyor, current feedback operational amplifier, operational transconductance amplifier and four terminal floating nullor [1-2]. All-pass filters are one of the most important building blocks of many analog signal processing applications and therefore have received much attention. They are generally used for introducing a frequency dependent delay while keeping the amplitude of the input signal constant over the desired frequency range. Other types of active circuits such as oscillators and high-Q band-pass filters are also realized by using all-pass filters [4-10]. The active devices that have been used for the realizations of the first order all-pass

circuits include operational amplifiers (OP-AMPS), second generation current conveyor (CCII), current feedback op-amps (CFOA), operational transconductance amplifier (OTA) and four terminal floating nullor (FTFN). Several voltage and current mode first order all-pass filters are available in literature [5-10]. A literature survey shows that there are only a few transadmittance type filters [4-13]. Since the introduction of CCIII by Fabre [10], a few applications have appeared in literature [10-13].

In this paper, CCIII-based current-mode first order all-pass filter configurations are proposed. Then a sinusoidal quadrature oscillator is implemented to show usefulness of the proposed configuration as an illustrating example. Furthermore, for non-ideal CCIII all-pass filter condition and oscillation condition and frequency are theoretically derived. Finally, PSPICE simulations are performed for the all-pass filter and oscillator circuits.

Received Date: 13.09.2005

Accepted Date: 25.03.2008

2. THE PROPOSED CIRCUITS

The part relations of an ideal dual-output CCIII, shown in Figure.1 can be given by

$$\begin{bmatrix} I_Y \\ V_X \\ I_{Z+} \\ I_{Z-} \end{bmatrix} = \begin{bmatrix} 0 & -1 & 0 & 0 \\ 1 & 0 & 0 & 0 \\ 0 & 1 & 0 & 0 \\ 0 & -1 & 0 & 0 \end{bmatrix} \begin{bmatrix} V_Y \\ I_X \\ V_{Z+} \\ V_{Z-} \end{bmatrix} \quad (1)$$

The proposed all-pass filter configuration is shown in Figure.2 Routine analysis yields the current-mode transfer function of the filter as follows;

$$\frac{I_{out}}{I_{in}} = \frac{sC_1R_1 - 1}{1 + sC_1R_1} \quad (2)$$

This transfer function allows the designer both inverting and non-inverting types of first order current mode all-pass filters by exchanging C_1 and R_1 and using only a single CCIII. Phase angle of the filter is computed as

$$\varphi = \pi - 2 \arctan \omega R_1 C_1 \quad (3)$$

3. QUADRATURE OSCILLATOR AS AN ALL-PASS FILTER APPLICATION

It is a well-known fact that a sinusoidal quadrature oscillator can be realized using an all-pass section and an integrator [14] as shown in Figure.3. Using this block diagram, CCIII-based current mode quadrature oscillator can be implemented as shown in Figure.4. In this circuit, the proposed all-pass filter and a current-mode integrator employing a CCIII are used. For providing a sinusoidal oscillation the loop gain of the circuit is set to unity at $s = j\omega$, i.e.

$$\left(\frac{s - \frac{1}{R_1 C_1}}{s + \frac{1}{R_1 C_1}} \right) \left(\frac{1}{s R_2 C_2} \right)_{s=j\omega} = -1 \quad (4)$$

From Equation (4) oscillation condition and frequency can be found respectively as

$$R_2 C_2 = R_1 C_1 \quad (5)$$

$$\omega_0 = \sqrt{\frac{1}{R_1 C_1 R_2 C_2}} \quad (6)$$

For simplicity, if we choose $R_1 = R_2 = R$ and $C_1 = C_2 = C$, then oscillation condition is satisfied and oscillation frequency becomes

$$\omega_0 = \frac{1}{RC} \quad (7)$$

The sensitivity analysis of this oscillator shows that $S_{R_1}^{\omega_0} = S_R^{\omega_0} = S_{C_1}^{\omega_0} = S_C^{\omega_0} = -1/2$ which are less than unity in magnitude.

4. NON-IDEAL CASE

By taking into account the deviations of the voltage and current gains from their ideal values, the definition equation of the CCIII in Figure.1 is described by

$$\begin{bmatrix} I_Y \\ V_X \\ I_{Z+} \\ I_{Z-} \end{bmatrix} = \begin{bmatrix} 0 & -\alpha & 0 & 0 \\ \beta & 0 & 0 & 0 \\ 0 & \gamma & 0 & 0 \\ 0 & -\delta & 0 & 0 \end{bmatrix} \begin{bmatrix} V_Y \\ I_X \\ V_{Z+} \\ V_{Z-} \end{bmatrix} \quad (8)$$

where α , β , γ and δ denotes the current and voltage gains. Also these gains represent non-idealities and tracking error parameters of the CCIII. Expression (1) is recovered from (8) as a special case, when all gains are equal to unity. Taking the effect of the tracking error parameters of the CCIII into account, the expression for the current gain transfer function of all-pass filter shown in Figure.2 is calculated as

$$H(s) = \left(\frac{-\gamma}{\alpha\beta - \delta + 1} \right) \frac{1 - [(\beta - 1)R + \beta R]sC_1}{1 + \frac{(\alpha\beta - \delta + 1)R_1 + (\alpha\beta + \beta\delta - \alpha - \beta - \delta + 1)R}{\alpha\beta - \delta + 1} sC_1} \quad (9)$$

It is evidence that filter gain and pole frequency are influenced by the tracking error parameters of the CCIII. From (9) all-pass filter condition is given by

$$(\beta - 1)R + \beta R_1 = \frac{(\alpha\beta - \delta + 1)R_1 + (\alpha\beta + \beta\delta - \alpha - \beta - \delta + 1)R}{\alpha\beta - \delta + 1} \quad (10)$$

From all-pass filter condition (10), it comes out that $\beta = 1$ condition must be satisfied. If

all-pass filter conditions given above are used in Equation (9), then magnitude of transfer function becomes

$$|H(j\omega)| = \frac{\gamma}{\alpha - \delta + 1} \quad (11)$$

In this case, filter gain is only influenced by tracking error parameters of the CCIII and is slightly different than unity. But it doesn't depend on passive element values used in the circuit. Sensitivity analysis of filter gain with respect to tracking error parameters of the CCIII yields

$$S_{\gamma}^{|H|} = 1, \quad S_{\alpha}^{|H|} = \frac{-\alpha}{\alpha - \delta + 1},$$

$$S_{\delta}^{|H|} = \frac{\delta}{\alpha - \delta + 1} \quad (12)$$

It is clearly seen from Equation (11) that $|H|$ sensitivities are equal to unity or less than unity.

Taking into account the non-ideal CCIII in the oscillator circuit, characteristic equation of the oscillator circuit shown in Figure.4 is obtained as

$$1 + \frac{\delta\beta\gamma[1 - (\beta-1)R + \beta R]sC_1}{[sC_2R_2 + \beta(\alpha-\gamma)][\alpha\beta-\delta+1 + (\alpha\beta-\delta+1)R_1 + (\alpha\beta + \beta\delta - \alpha - \beta - \delta + 1)R]sC_1} = 0 \quad (13)$$

In this derivation, it is assumed that all CCIII used in the quadrature oscillator circuit have same gain parameters. For non-ideal CCIII the modified oscillation condition and oscillation frequency are respectively

$$C_1R_1(\alpha\beta-\delta+1) + \beta(\alpha-\gamma)C_1[(\alpha\beta-\delta+1)R_1 + (\alpha\beta + \beta\delta - \alpha - \beta - \delta + 1)R] - \delta\beta\gamma[(\beta-1)R + \beta R] = 0 \quad (14)$$

$$\omega_o = \sqrt{\frac{\beta(\alpha-\gamma)(\alpha\beta-\delta+1)}{R_1C_1C_2[(\alpha\beta-\delta+1)R_1 + (\alpha\beta + \beta\delta - \alpha - \beta - \delta + 1)R]}} \quad (15)$$

Expressions (5) and (6) which is given for ideal case are recovered from (14) and (15) as a special case when all gains of CCIII are equal to unity. Note that oscillation frequency depends on both gain parameters of the CCIII and passive element values as well.

5. SIMULATION RESULTS

To verify the theoretical study, the first order all-pass filter was constructed and simulated with PSPICE program. For this purpose, passive components were chosen as $R=50\Omega$, $R_1=100\Omega$, and $C=10\text{nF}$, which results in a 159 KHz center frequency. Since there is no any commercial implementation of the CCIII, the PSPICE simulations were performed using a CMOS realization of CCIII and by MIETEC 0.5 μm MOS transistor parameters[13]. The supply voltages were taken as $V_{DD} = 2.5V$ and $V_{SS} = -2.5V$. Simulated magnitude and phase response of the filter is given in Figure.5, which are in good agreement with the predicted theory. Actually, non-idealities and the parasitic resistances and capacitances of the CCIII, that is not mentioned in the limited space available here, cause the deviations in the frequency and phase response of the filter from theoretical values. Figure.6 shows the time-domain response of the filter. A sinusoidal input at the frequency of 159kHz was applied to the all-pass network constructed with above mentioned passive element values. Quadrature oscillator employing the proposed all-pass filter has also been simulated using PSPICE. In this simulation all resistances and capacitances were taken as 50 Ω and 10nF respectively which results in a 159kHz oscillation frequency. The output waveforms of the oscillators are shown in Figure.7. Actually, the parasitic resistances and capacitances and non-idealities of the MOS CCIII, cause the deviations in the time-domain responses of the filter from theoretical values

6. CONCLUSION

Current-mode first order all-pass filter configuration is presented. The proposed circuit uses only a single CCIII, a capacitor and resistors. Since the output of the filter exhibits low impedance the synthesized current-mode filters can be cascaded without additional buffers. The proposed allpass filter were employed to implement the quadrature oscillator. As an application of the allpass filter, a new quadrature oscillator was realized. In non-ideal case, allpass filter condition for the proposed allpass filter as well as

oscillation condition for quadrature oscillator were theoretically investigated. PSPICE simulations were performed by using CMOS realization of the CCIII. PSPICE simulation results of the time domain and frequency responses of the proposed circuits are in good agreement with the predicted theory.

REFERENCES

- [1] Toumazou, C., Lidjey, F. J., Haigh D., Analog IC Design: The Current-Mode Approach, Peter Peregrinus, UK, 1990.
- [2] Palmisano G., Palumbo G., Pennisi S., CMOS Current Amplifiers, Kluwer Academic Publishers, 1999.
- [3] Mucha I., Current operational amplifiers: Basic architectures, properties, exploitation and future, Analog Integrated Circuits and Signal Processing, Vol.24, pp.243-255, 1995
- [4] Schauman, R., Valkenburg, M. E., Design of analog filters. Oxford University Press, New York, 2001.
- [5] Donald, T. C., David, J. C., Jason, R. G., A high frequency integrable band-pass filter configuration, IEEE Transaction on Circuits and Systems-II, Vol. 44, pp. 856-860, 1997.
- [6] Cicekoglu, O., Kuntman, H., S. Berk, Single CII+ based all-pass filters, Int. Journal of Electronics, Vol.86, pp. 947-955, 1988.
- [7] Çam, U., Cicekoglu, O., Gulsoy, M., Kuntman, H., New voltage and current mode first-order all-pass filters using single FTFN, Frequenz, Vol.7-8, pp. 177-179, 2000.
- [8] Higashimura, M., Fukai, Y., Realization of all-pass and notch filters using a single current conveyor, Int. Journal of Electronics, Vol.65, pp. 823-828, 1988.
- [9] Toker, A., Ozoguz, S., Cicekoglu, O., Acar, C., Current mode all-pass filters using current differencing buffered amplifier and new high-Q band-pass filter configuration, IEEE Transaction on Circuits and Systems-II, Vol. 47, pp. 949-954, 2000.
- [10] Fabre, A., Third generation current conveyor: A new helpfull active element, Electronics Letters, Vol.31, pp.338-339, 1995.
- [11] Sudanshu, M., Iqbal, A. K., Novel first order allpass section using single CCIII, Int. Journal of Electronics, Vol.88, pp. 773-778, 2001.
- [12] Wang, H. Y., Lee, C. T., Systematic synthesis R-L and C-D immitances using single CCIII, Electronics Letters, Vol.87, pp.293-294, 2000.
- [13] Minai, S., A new high performance CMOS third generation current conveyor (CCIII) and its application, Electrical Engineering, Vol.8, pp.147-153, 2003.
- [14] Ahmet, M. T., Khan, I. A., Minhej, N., On transconductance quadrature oscillators, Int. Journal of Electronics, Vol.83(2), pp. 201-207, 1997.

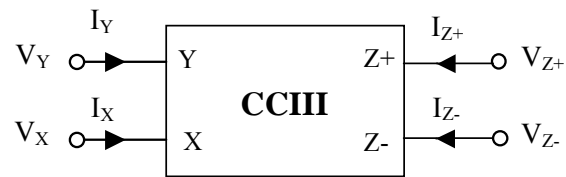

Figure 1. Symbol of the CCIII

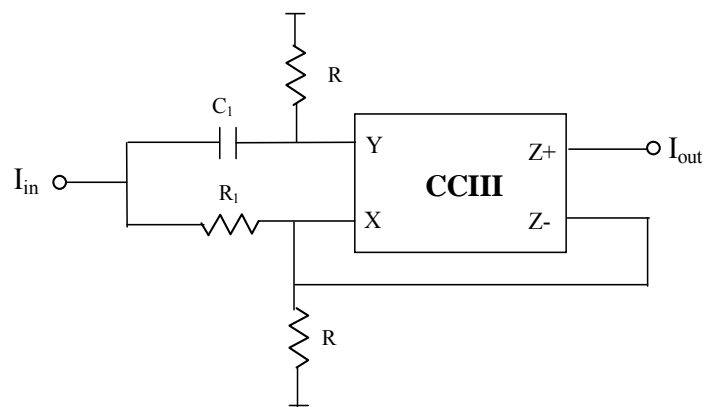

Figure 2. The proposed current-mode first order all-pass filter configuration

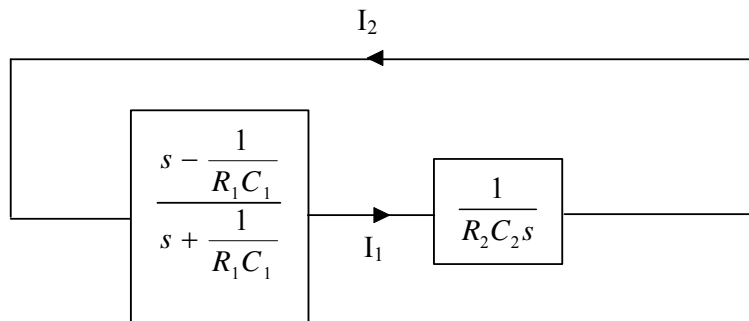

Figure 3. Realization block diagram for quadrature oscillator

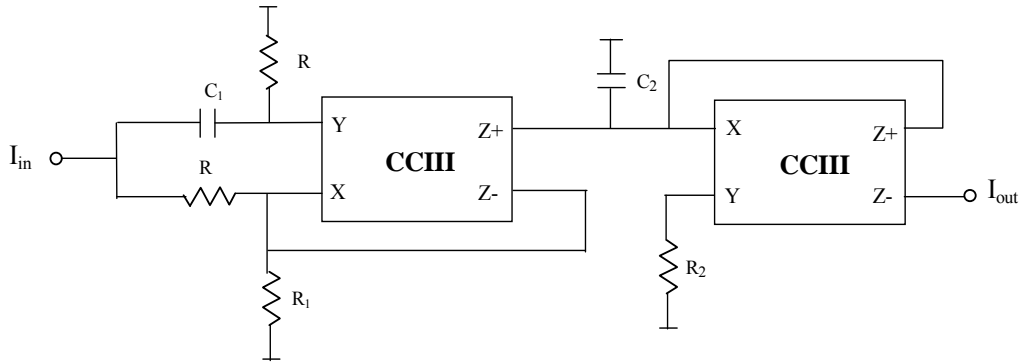

Figure 4. CCIII-based quadrature oscillator circuit

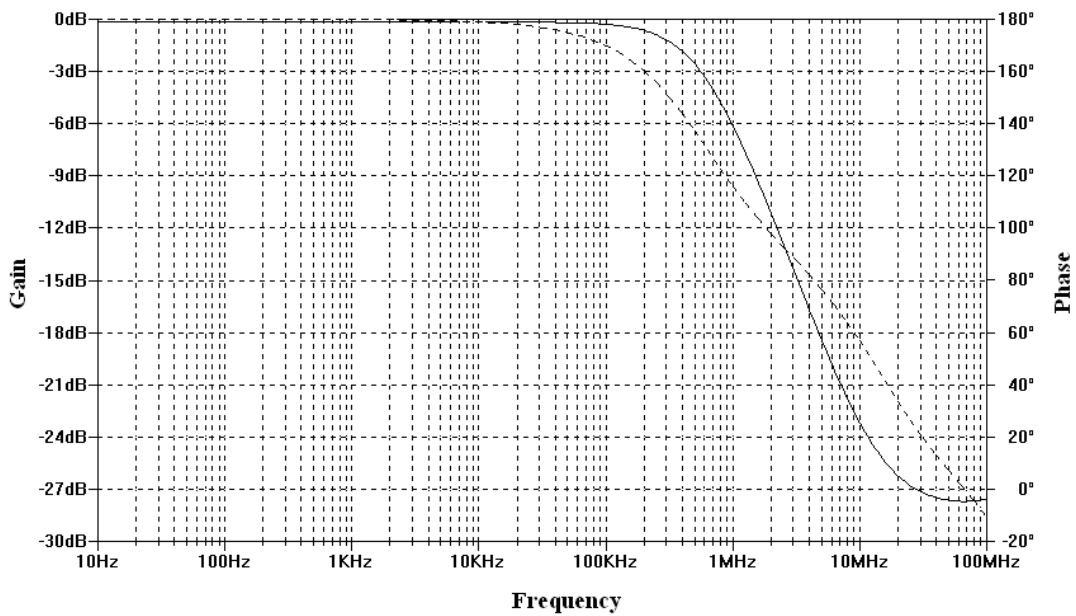

Figure 5. PSPICE simulation result of the proposed current-mode first order all-pass filter (amplitude —, phase ---)

THIRD GENERATION CURRENT CONVEYOR BASED CURRENT-MODE FIRST ORDER ALL-PASS FILTER AND QUADRATURE OSCILLATOR

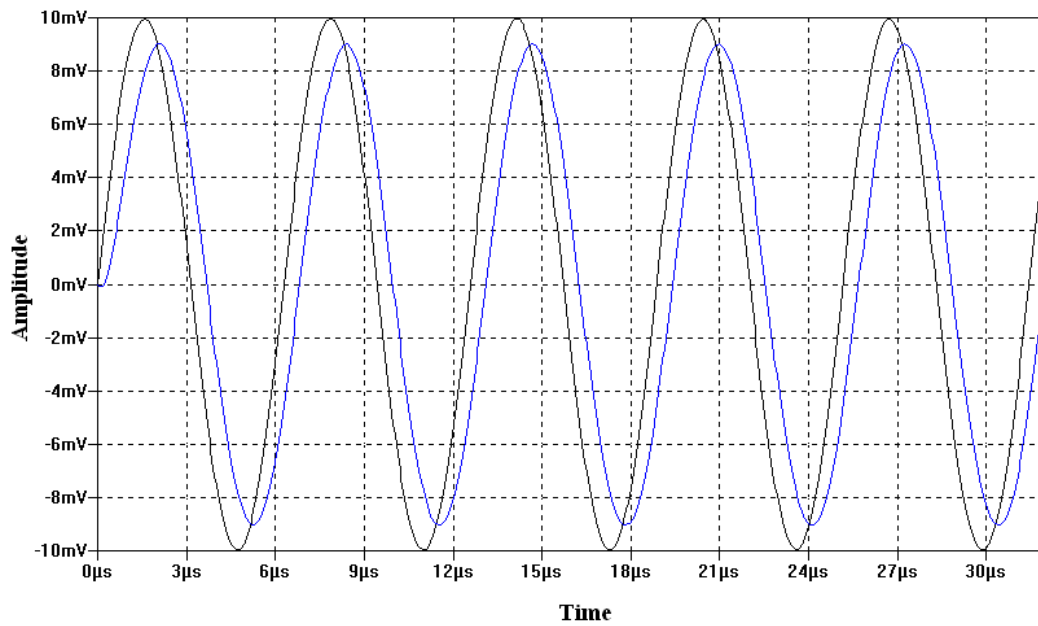

Figure 6. Simulated time-domain response of the proposed all-pass filter (input: ▲, output: ■)

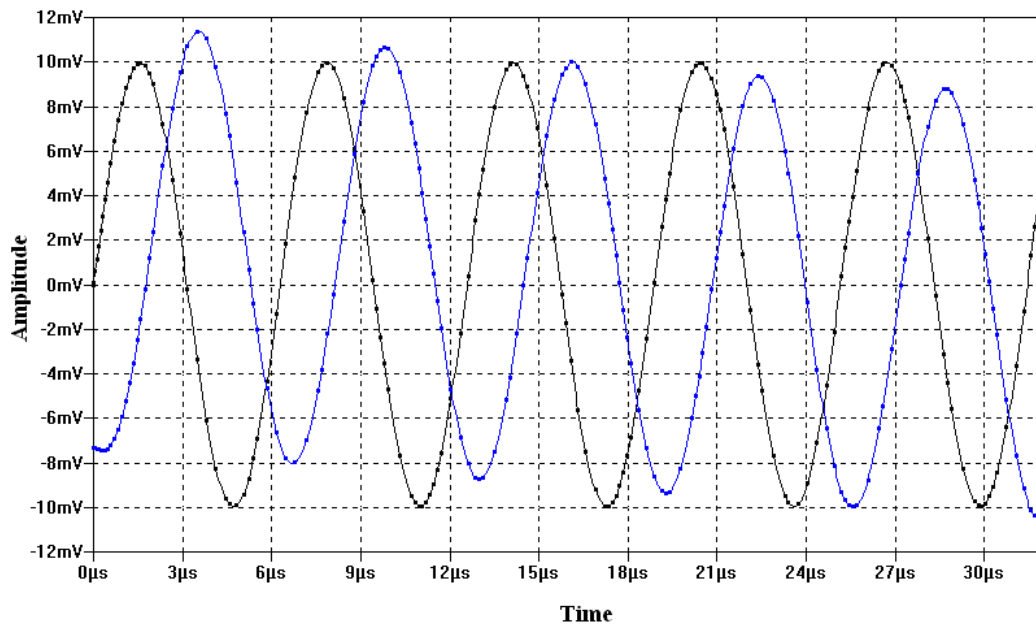

Figure 7. Sinusoidal output waveforms of the quadrature oscillator (input: ▲, output: ■)