

FUZZY SLIDING MODE APPLICATION FOR INDUCTION MACHINE POSITION CONTROL

Mohamed ABID¹, Abdel ghani AISSAOUI², Abdel ghani AYAD³ and
Ahmed TAHOUR⁴

^{1,2,3}IRECOM Laboratory, Department of Electrical Engineering, Djillali Liabès University of Sidi
Bel-Abbès, Algeria.

⁴ Department of Technical sciences, Mascara University, Algeria.
E-mail: irecom_mabid@yahoo.fr

Abstract

The use of the sliding mode control can give good transient performances and system robustness. However, the presence of the chattering may introduce problems to the system. In order to utilize the advantage of both fuzzy and sliding mode controls, a fuzzy sliding mode controller (FSMC) is proposed for position control. In this paper, we propose a fuzzy sliding mode controller to control the position of the field-oriented induction machine fed by voltage source inverter. Our aim is to make the position control robust to parameter variations. Simulation results are given to highlight the performances of the proposed control technique under load disturbances and parameter uncertainties.

Keywords: *Induction machine, field-oriented control, robustness, fuzzy sliding mode control, position control.*

1. INTRODUCTION

The induction machine is one the most widely used actuators for industrial application owing to its reliability, ruggedness and relatively low cost. Furthermore, its uses position and speed tracking control, is expected to increase in the near future. Based on the forecast, many researchers have proposed the use of modern control techniques for the precise control of induction machine. [6-9]

The control of the induction machine (IM) must take into account machine specificities: the high order of the model, the nonlinear functioning as well as the coupling between the different variables of control. Furthermore, the machine parameters depend generally on the operating point and vary either on the temperature (resistance), or with the magnetic state of the induction machine, without taking into account

the variation. These parametric variations modify the performances of the control system when we use a regulator or a control law with fixed parameters. The new industrial applications necessitate position and speed variators having high dynamic performances, a good precision in permanent regime, and a high capacity of overload on all the range of position / speed and a robustness to the different perturbations. Thus, the recourse to robust control algorithms is desirable in stabilization and in tracking trajectories. The variable structure control (VSC) possesses this robustness using the sliding mode control that can offer many good properties such as good performance against unmodelled dynamics, insensitivity to parameter variation, external disturbance rejection and fast dynamic [1-5]. These advantages of sliding mode control can be employed in the position and speed control of an alternative current servo system.

Received Date : 10.11.2008

Accepted Date: 26.10.2009

However, there exists a chattering phenomenon when implementing a sliding mode control and this may excite high-frequency dynamics. Moreover, the specification of the approximation model as well as the boundary of model uncertainty and unknown disturbance is usually a difficult task in most situations. One way to eliminate chattering is to introduce a thin boundary layer neighboring the sliding surface [3].

In this work, motivated by the sliding mode technique, we emerge the fuzzy logic into the design of sliding mode control and propose a fuzzy sliding mode controller for position control (PFSMC).

This paper is organized as follows. The orient model of an induction motor is introduced in section 2. In section 3, the observers of rotor flux is presented. Then, a brief description of sliding mode control and the design of the sliding mode controllers of rotor flux and motor position are presented in section 4. The section 5 presents the design of fuzzy sliding mode controller for position. In section 6, the proposed control of IM using fuzzy sliding mode is delineated and some simulation results are presented. Finally, some concluding remarks are stated in the last section.

2. INDUCTION MOTOR ORIENTED MODEL

An induction machine model can be described by the following state equations in the synchronous reference frame whose axis d is aligned with the rotor flux vector, ($\Phi_{rd} = \Phi_r$ and $\Phi_{rq} = 0$) [8-10]:

$$\dot{i}_{sd} = -\gamma i_{sd} + \omega_s i_{sq} + \frac{K}{T_r} \Phi_{rd} + \frac{1}{\delta L_s} u_{sd} \quad (1)$$

$$\dot{i}_{sq} = -\omega_s i_{sd} - \gamma i_{sq} - P\Omega K \Phi_{rd} + \frac{1}{\delta L_s} u_{sq} \quad (2)$$

$$\dot{\Phi}_{rd} = \frac{M_{sr}}{T_r} i_{sd} - \frac{1}{T_r} \Phi_{rd} \quad (3)$$

$$\dot{\Phi}_{rq} = \frac{M_{sr}}{T_r} i_{sq} - (\omega_s - P\Omega) \Phi_{rd} \quad (4)$$

$$\dot{\Omega} = \frac{PM_{sr}}{JL_r} (\Phi_{rd} i_{sq}) - \frac{T_l}{J} - \frac{f}{J} \Omega \quad (5)$$

With:

$$T_r = \frac{L_r}{R} ; \delta = 1 - \frac{M_{sr}^2}{L_s L_r} ;$$

$$K = \frac{M_{sr}}{\delta L_s L_r} ; \gamma = \frac{R_s}{\delta L_s} + \frac{R_r M_{sr}^2}{\delta L_s L_r^2}$$

Where Φ_{rd}, Φ_{rq} are rotor flux components, u_{sd}, u_{sq} are stator voltage components, i_{sd}, i_{sq} are stator current components, δ is leakage factor and p is number of pole pairs. R_s and R_r are stator and rotor resistances, L_s and L_r denote stator and rotor inductances, whereas M_{sr} is mutual inductance. T_e is the electromagnetic torque, T_l is the load torque, J is the moment of inertia of the IM, Ω is mechanical speed, ω_s is stator pulsation, f is damping coefficient, T_r is rotoric time-constant.

3. FLUX ESTIMATOR

For direct field-oriented control of induction machine, accurate knowledge of the magnitude and the position of the rotor flux vector is necessary. In a normal cage motor, as rotor current are not measurable, the rotor flux should be estimated. Various types of estimators and observes have been proposed in the literature. The flux estimator, used in this work is based on the integration of the stator voltage equations in the stationary frame. The flux estimator can be obtained by the following equations [12]:

$$\dot{\hat{\Phi}}_{r\alpha} = \frac{L_r}{M_{sr}} (u_{s\alpha} - R_s i_{s\alpha} - \delta L_s \dot{i}_{s\alpha}) \quad (6)$$

$$\dot{\hat{\Phi}}_{r\beta} = \frac{L_r}{M_{sr}} (u_{s\beta} - R_s i_{s\beta} - \delta L_s \dot{i}_{s\beta}) \quad (7)$$

θ_s is the angle between rotoric vector flux Φ_r and the axis of the (α, β) frame

$$\theta_s = \arctan \left(\frac{\hat{\Phi}_{r\beta}}{\hat{\Phi}_{r\alpha}} \right) \quad (8)$$

Where $\hat{\Phi}_{r\alpha}, \hat{\Phi}_{r\beta}$ are the estimated rotor flux components, $i_{s\alpha}, i_{s\beta}$ are the measured stator current components.

4. SLIDING MODE CONTROL DESIGN

Sliding mode control is developed from variable structure control. It is a form of linear control providing a robust means of controlling the nonlinear plants with disturbances and parameters uncertainties.

Sliding mode is the technique to adjust feedback by previously defining a surface so that the system which is controlled will be forced to that surface then the behavior system slides to the desired equilibrium point.

This control consists in two phases:

The first phase is choosing a sliding manifold have a desired dynamics, usually linear and of a lower order.

The second phase is designing a control law, which will drive the state variable to the sliding manifold and will keep them there.

The design of the control system will be demonstrated for a following nonlinear system: [1-7]

$$\dot{x} = f(x, t) + B(x, t) u(x, t) \tag{9}$$

Where $x \in \mathfrak{R}^n$ is the state vector, $u \in \mathfrak{R}^m$ is the control vector, $f(x, t) \in \mathfrak{R}^n$, $B(x, t) \in \mathfrak{R}^{n \times m}$.

From the system (9), it possible to define a set S of the state trajectories x such as:

$$S = \{x(t) \mid \sigma(x, t) = 0\} \tag{10}$$

Where

$$\sigma(x, t) = [\sigma_1(x, t), \sigma_2(x, t), \dots, \sigma_m(x, t)]^T \tag{11}$$

and $[.]^T$ denotes the transposed vector, S is called the sliding surface.

To bring the state variable to the sliding surfaces, the following two conditions have to be satisfied:

$$\sigma(x, t) = 0, \quad \dot{\sigma}(x, t) = 0 \tag{12}$$

The control law satisfies the precedent conditions is presented in the following form:

$$u = u^{eq} + u^n \tag{13}$$

Where u is the control vector, u^{eq} is the equivalent control vector, u^n is the switching part of the control (the correction factor)

u^{eq} can be obtained by considering the condition for the sliding regimen, $\sigma(x, t) = 0$. The equivalent control keeps the state variable on sliding surface, once they reach it.

U^n is needed to assure the convergence of the system states to sliding surfaces in finite time.

In order to alleviate the undesirable chattering phenomenon, J. J. Slotine proposed an approach to reduce it, by introducing a boundary layer of width ϕ either side of the switching surface [3].

Then, u^n is defined by

$$u^n = K \text{sat}(\sigma(x)/\phi) \tag{14}$$

Where $\text{sat}(\sigma(x)/\phi)$ is the proposed saturation function, ϕ is the boundary layer width, K is the controller gain designed from the Lyapunov stability

$$V = \frac{1}{2} \sigma^2 \tag{15}$$

$$\dot{V} = \frac{1}{2} \frac{d}{dt} \sigma^2 = \sigma \dot{\sigma} \leq -\eta |\sigma| \tag{16}$$

Where η is a strictly positive constant.

In this work, $s(x, t)$ is the sliding mode vector proposed by J. J. Slotine [3].

$$\sigma(x) = \left(\frac{d}{dt} + \lambda \right)^{n-1} e \tag{17}$$

Where

$x = [x, \dot{x}, \dots, x^{n-1}]^T$ is the state vector,

$x^d = [x^d, \dot{x}^d, \dots, x^{d,n-1}]^T$ is the desired state vector,

$e = x^d - x = [e, \dot{e}, \dots, e^{n-1}]$ is the error vector,

and λ is a vector of slopes of the S.

Commonly, in IM control using sliding mode theory, the surfaces are chosen as functions of the error between the reference input signal and the measured signals [2]. After this step, the objective is to determine a control law which drives the state trajectories along the surface.

4.1 POSITION CONTROL

To control the position of the induction machine, three surfaces are chosen. Variables of control are the rotation position and the flux Φ_r . The flux will be maintained at its nominal value to have a maximal torque.

We take $n=1$, the position control manifold equations can be obtained as:

$$\sigma(\theta) = \lambda_\theta (\theta_{ref} - \theta) + \frac{d}{dt} (\theta_{ref} - \theta) \tag{18}$$

$$\dot{\sigma}(\theta) = \lambda_\theta (\dot{\theta}_{ref} - \dot{\theta}) + \frac{d}{dt} (\dot{\theta}_{ref} - \dot{\theta}) \tag{19}$$

With

$$\frac{d}{dt}\theta = \dot{\theta} = \Omega \quad (20)$$

$$\frac{d}{dt}\Omega = \frac{PL_m}{JL_r}\phi_{rd}^{ref}i_{sq} - \frac{f}{J}\Omega - \frac{T_l}{J} \quad (21)$$

Substituting the expression of $\dot{\Omega}$ defined by equation (21) in equation (19), we obtain:

$$\dot{\sigma}(\theta) = \lambda_\theta \dot{\theta}_{ref} + \ddot{\theta}_{ref} + \left(\frac{f}{J} - \lambda_\theta\right)\Omega + \frac{T_l}{J} - \frac{PM_{sr}}{JL_r}\phi_{rd}^{ref}i_{sq} \quad (22)$$

Substituting the expression of i_{sq} by $i_{sq}^{eq} + i_{sq}^n$ the command clearly appears in the equation before.

$$\dot{\sigma}(\theta) = \lambda_\theta \dot{\theta}_{ref} + \ddot{\theta}_{ref} + \left(\frac{f}{J} - \lambda_\theta\right)\Omega + \frac{T_l}{J} - \frac{PM_{sr}}{JL_r}\phi_{rd}^{ref}\left(i_{sq}^{eq} + i_{sq}^n\right) \quad (23)$$

During the sliding mode and in permanent regime, we have:

$$\sigma(\theta) = 0, \quad \dot{\sigma}(\theta) = 0, \quad i_{sq}^n = 0 \quad (24)$$

Where the equivalent control is:

$$i_{sq}^{eq} = \frac{JL_r}{PM_{sr}\phi_{rd}^{ref}} \left(\lambda_\theta \dot{\theta}_{ref} + \ddot{\theta}_{ref} + \left(\frac{f}{J} - \lambda_\theta\right)\Omega + \frac{T_l}{J} \right) \quad (25)$$

During the convergence mode, the condition $\sigma(\theta)\dot{\sigma}(\theta) \leq 0$ must be verified. We obtain:

$$\dot{\sigma}(\theta) = -\frac{PM_{sr}\phi_{rd}^{ref}}{JL_r}i_{sq}^n \quad (26)$$

Therefore, the correction factor is given by:

$$i_{sq}^n = Ki_{sq} \text{sign}(\sigma(\theta)) \quad (27)$$

To verify the system stability condition, the parameter Ki_{sq} must be positive.

In order to limit all possible overshoot of the current I_{sq} , we add a limiter of current defined by

$$i_{sq}^{lim} = i_{sq}^{max} \text{sat}(i_{sq}) \quad (28)$$

4.2. STATOR CURRENT CONTROL

In order to limit all possible overshoot of the current i_{sq} , we add a limiter of current defined by

$$i_{sq}^{lim} = i_{sq}^{max} \text{sat}(i_{sq}) \quad (29)$$

The current control manifold is

$$\sigma(i_{sq}) = i_{sq}^{lim} - i_{sq} \quad (30)$$

$$\dot{\sigma}(i_{sq}) = \dot{i}_{sq}^{lim} - \dot{i}_{sq} \quad (31)$$

Substituting the expression of \dot{i}_{sq} equation 2 in equation (31), we obtain:

$$\dot{\sigma}(i_{sq}) = \dot{i}_{sq}^{lim} - \left(-\omega_s i_{sd} - \gamma i_{sq} - P\Omega K\Phi_{rd}\right) - \frac{1}{\delta L_s} u_{sq} \quad (32)$$

The control voltage is

$$u_{sq}^{ref} = u_{sq}^{eq} + u_{sq}^n \quad (33)$$

$$u_{sq}^{eq} = \delta L_s \left(\dot{i}_{sq}^{lim} + \omega_s i_{sd} + \gamma i_{sq} + P\Omega K\Phi_{rd} \right) \quad (34)$$

$$u_{sq}^n = Ku_{sq} \text{sat}(\sigma(i_{sq})) \quad (35)$$

To verify the system stability condition, the parameter Ku_{sq} must be positive

4.3. ROTOR FLUX CONTROL

In the proposed control, we take $n=2$ to appear control u_{sd} , the manifold equation can be obtained by:

$$\sigma(\Phi_r) = \lambda_\Phi (\Phi_r^{ref} - \Phi_r) + (\dot{\Phi}_r^{ref} - \dot{\Phi}_r) \quad (36)$$

$$\dot{\sigma}(\Phi_r) = \lambda_\Phi (\dot{\Phi}_r^{ref} - \dot{\Phi}_r) + (\ddot{\Phi}_r^{ref} - \ddot{\Phi}_r) \quad (37)$$

The control voltage

$$u_{sd} = u_{sd}^{eq} + u_{sd}^n \quad (38)$$

$$u_{sd}^{eq} = \delta L_s \left(\dot{\Phi}_r^{ref} + \lambda_\Phi \dot{\Phi}_r^{ref} + \left(\frac{1}{T_r} - \lambda_\Phi\right) \dot{\Phi}_r \right) \frac{T_r}{M_{sr}} - \delta L_s \left(-\gamma i_{sd} + \omega_s i_{sq} + \frac{K}{T_r} \Phi_{rd} \right) \quad (39)$$

$$u_{sd}^n = Ku_{sd} \text{sat}(\sigma(\Omega)) \quad (40)$$

To verify the system stability condition, the parameter Ku_{sd} must be positive.

The selection of coefficients Ki_{sq} , Ku_{sd} , Ku_{sq} and λ_Φ must be done in order to satisfy following requirements:

- Existence condition of the sliding mode, which requires that the state trajectories are directed toward the sliding manifold,

- Hitting condition, which requires that the system trajectories encounter the manifold sliding irrespective of their starting point in the state space (insure the rapidity of the convergence),
- Stability of the system trajectories on the sliding manifold,
- Not saturate the control to allow the application of the control discontinuous.

5. POSITION FUZZY SLIDING MODE CONTROL

In this section, the fuzzy logic control is applied in order to find a suitable control so that the system response track desired reference trajectories.

With the switching control term $i_{sq}^n = Ki_{sq} sign(\sigma(\theta))$, if Ki_{sq} is chosen too large, the control effort results large chattering. The chattering phenomenon in the control effort will wear the bearing mechanism and excite unstable dynamics. if Ki_{sq} is chosen too small, the control may be unstable[13-17].

In this work, we replace the switching control term $i_{sq}^n = Ki_{sq} sign(\sigma(\theta))$ by an inference fuzzy system for reduced the chattering phenomenon.

The proposed fuzzy sliding mode control, which is designed to control the motor position, is shown in Fig. 1.

The simplest five rules, selected five input-output linguistic variables, which are: NB-for negative big, NM-for negative medium, EZ-for zero, PM-for positive medium, PB-for positive

big. NB, M, ..., SMALL, SMALLER are linguistic terms of fuzzy sets and their corresponding membership functions are depicted in figure 2.

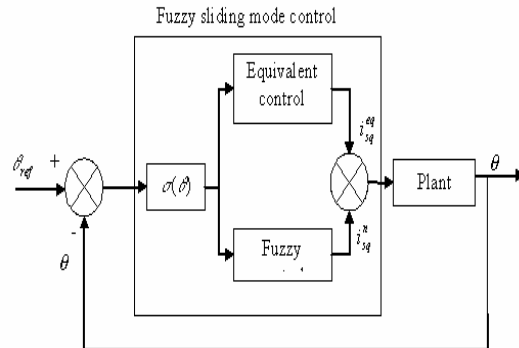

Fig. 1 Block diagram of the proposed position fuzzy sliding mode controller.

The rules base can be written as shown in the Table 1.

Fuzzy input $\sigma(\theta)$	NB	NM	EZ	PM	PB
Fuzzy output i_{sq}^f	BIGGER	BIG	MEDIUM	SMALL	SMALLER

Table 1. The rules base of the PFSM

For this purpose, it is used a Mamdani-type fuzzy logic system. The membership function of the result aggregation is by maximum method. The control output is accomplished by using the Mean Maximum operator. The defuzzification is centroid method.

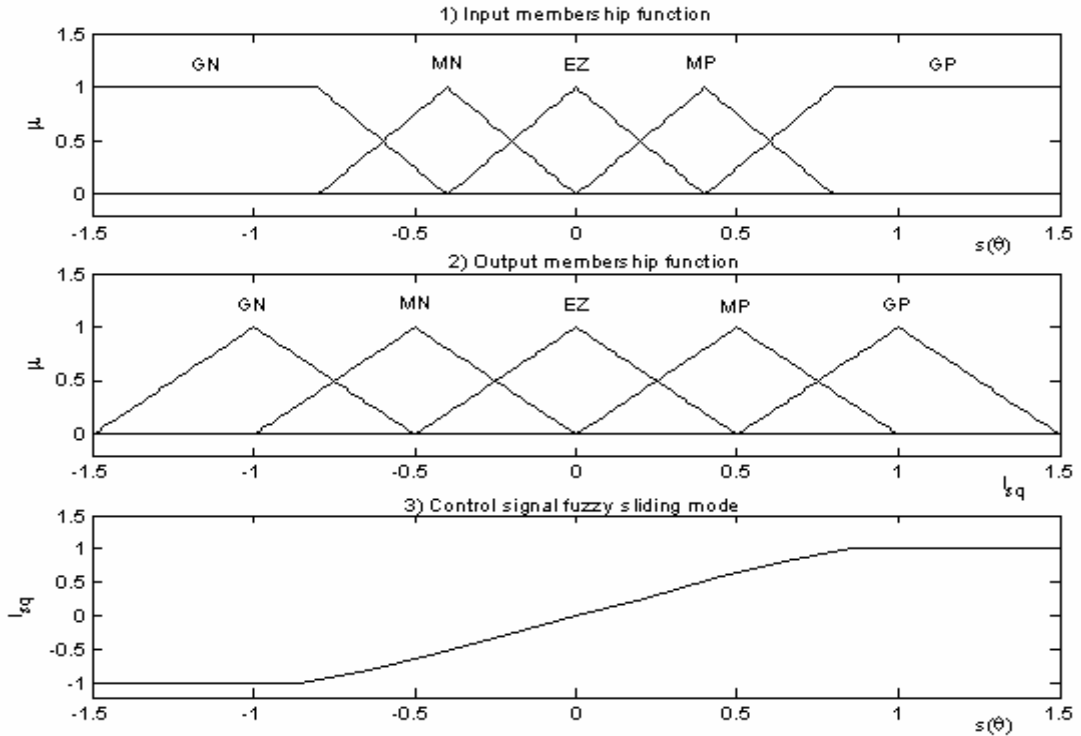

Fig. 2 The membership functions sets for the PFSMC: 1) The input membership functions of the PFSMC; 2) The output membership functions of the PFSMC; 3) The control signal of fuzzy mode controller PFSMC

6. SIMULATION RESULTS

The proposed robust control scheme of machine drive system is shown in Fig.3. The blocks PFSMC, SMC2, SMC3 represent the proposed sliding mode controllers, rotor position, stator current, flux, respectively. The block limiter limits the current within the limits values. The block ‘Coordinate transform’ makes the conversion between the synchronously rotating and stationary reference frame. The block ‘Inverter’ shows that the motor is voltage fed. The block ‘Estimator’ represents respectively the

estimated stator current I_{sq} and the rotor flux Φ_r . The block ‘IM’ represents the induction motor. The IM used in this work is a 1.5 kW, $U=220$ V, 50 Hz, $P=2$, $I_n=6.1$ A, $\Phi_n=0.595$ Wb. IM parameters: $R_s=1.47$ Ω , $R_r=0.79$ Ω , $L_r = M_{sr}=0.094$ H, $L_s=0.105$ H. The system has the following mechanical parameters: $J=0.0256$ Nm/rad/s², $f=0.0029$ Nm/rad/s. The global system is simulated using MATLAB/SIMULINK software.

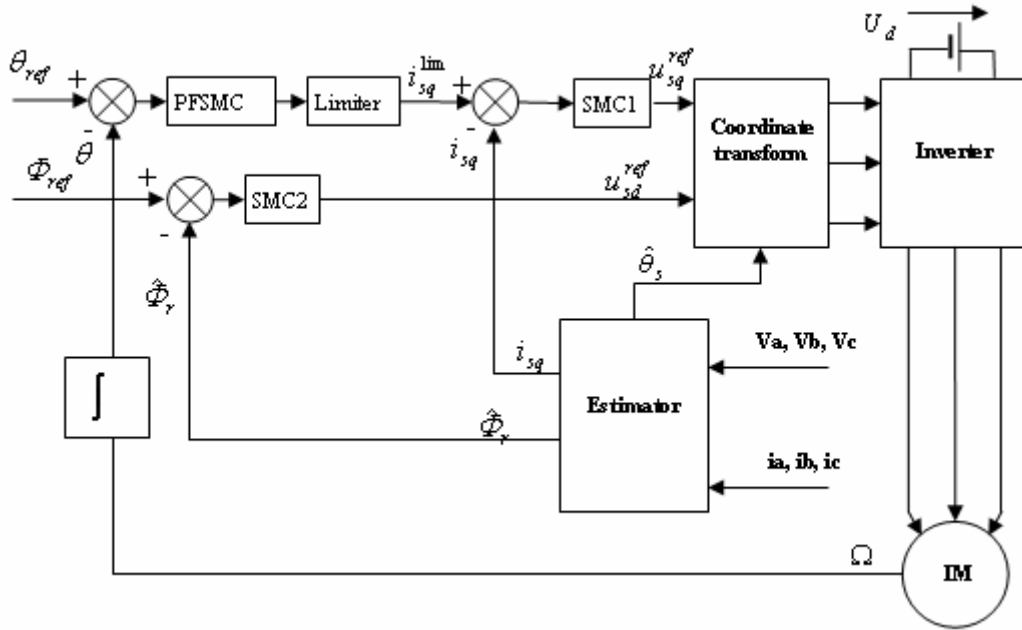

Fig. 3. Block diagram of the proposed control scheme of the IM.

7. RESULTS AND COMMENTS

The proposed control has been tested to illustrate its performances, we simulated a loadless starting up mode with the reference speed $\pm\pi$ and an application of the load torque ($T_l = \pm 10$ Nm) at time 1s to 2s, the reference flux is 0.595Wb (fig.2).

In order to test the robustness of the proposed control, we have studied the position performances control with current limitation. The

introduced variations in tests look in practice to work conditions as the magnetic circuit overheating and saturation. The considered case is: inertia variation, stator and rotor resistance variations, stator and rotor inductance and mutual variations.

Figure 5 present the system responses in nominal case. Figure 6 show the robustness tests in relation to variations parameters

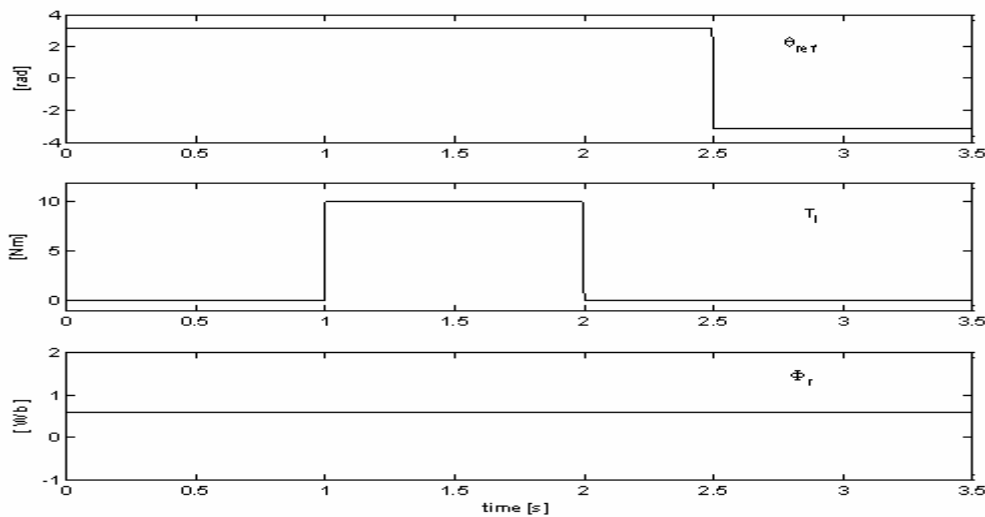

Fig. 4. Reference of position, rotor flux and load torque

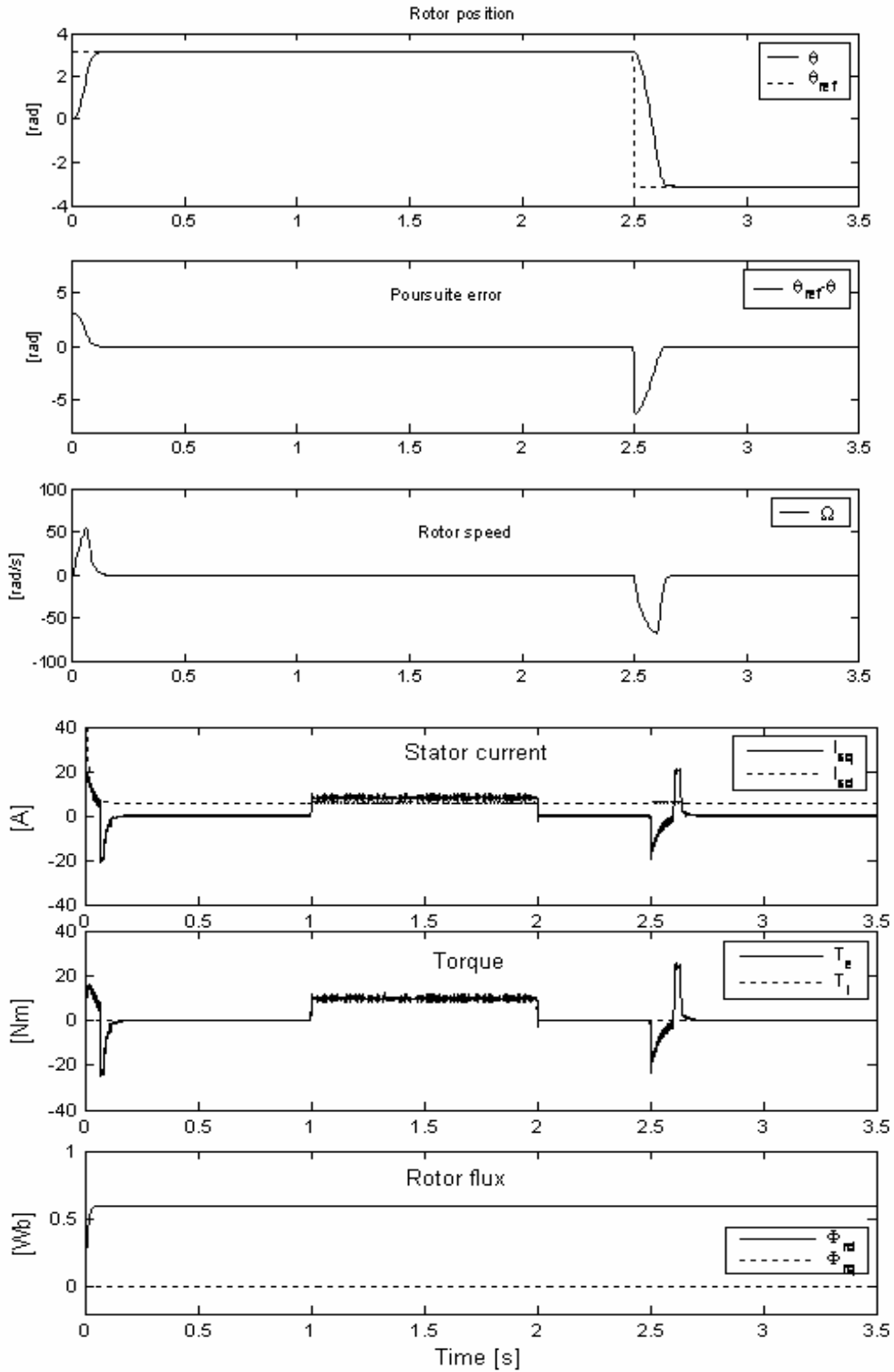

Fig. 5. System responses in nominal case.

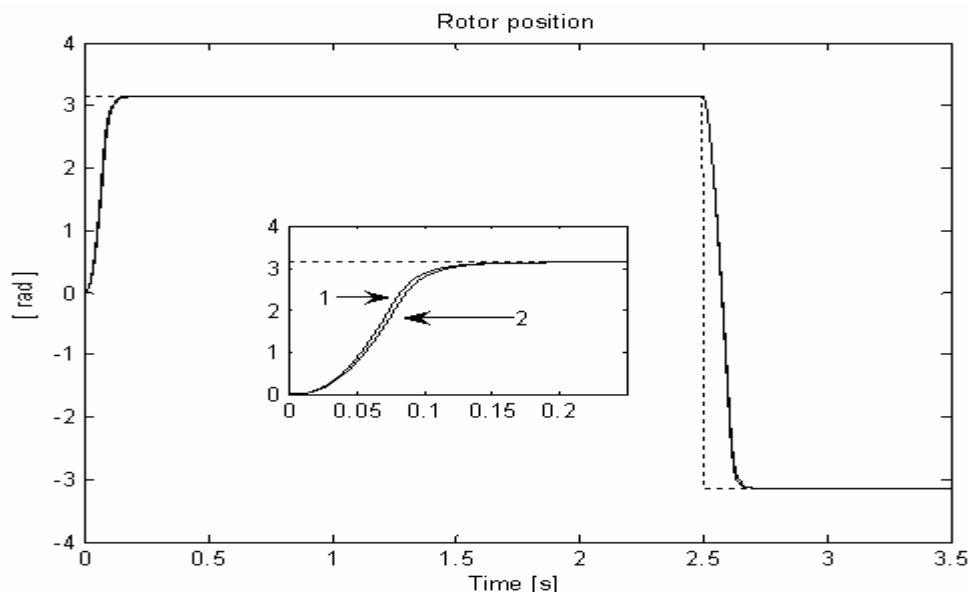

Fig. 6 Simulation results with the variation of parameters
(Curves 1: Nominal case; curves 2: (1.5 R_s , 1.5 R_r , 1.2 L_s , 1.2 L_r , 1.2 M_{sr} , 2J)).

From the system responses given in Fig 5, the position track the desired position with the instantaneously perturbation reject. The decoupling between the flux and torque is assured in permanent regime. The flux tracks the desired flux. It shows also the limited started torque. The i_{sd} corresponding to the flux component, remains constant because the flux is maintained constant and the current i_{sq} , corresponding to the torque component, varies with the torque.

The figure 6 show the parameter variation does not allocate performances of the proposed control. The position tracks the desired position and it is insensitive to parameter variations of the machine, without overshoot and without static error permanent regime, the perturbation reject is instantaneous.

The results show that high precision tracking can be achieved using fussy sliding mode controller in spite of parameters large variations.

8. CONCLUSION

In this work, a fuzzy sliding mode control method has been proposed and used for the position control of an induction machine using field oriented control. A simple algorithm to estimate the rotor flux is presented. the

simulation results show good performances obtained with the proposed control. The proposed controller presents high robustness in presence of the internal and the external perturbations. With a good choice of the control parameters, the chattering effects are reduced, and the torque fluctuations are decreased. The position control operates with enough stability and has strong robustness to parameter variations. The simulation results confirm the effectiveness of the proposed fuzzy sliding mode control method.

REFERENCES

- [1] V.I. Utkin, "Variable structure systems with sliding modes", *IEEE Trans. Automat. Contr.*, vol. AC-22, no. 2, pp.212-222, Apr.1977.
- [2] V. I. Utkin, "Sliding mode control design principles and applications to electric drives", *IEEE Trans. Ind. electronic.*, vol. 40, pp.23-36, Feb.1993.
- [3] J.J.E. Slotine, W. Li, *Applied nonlinear control*, Prence Hall, USA, 1998.
- [4] K.D Young, V.I Utkin, and U. Ozguner, "A control engineer's guide to Sliding mode control," *IEEETrans. Control Syst.Technol.*, vol. 7, pp.328-342, May.1997.
- [5] Buhler H. *Réglage par mode de glissement*, Presses polytechniques romandes (Lausanne, 1986).

- [6] M.H Park, K.S. Kim, "chattering reduction in the position control of induction motor using the sliding mode", *IEEE Trans. power Electron.*, vol. 2. pp.317-325.,1991.
- [7] E.Larouche, Y. Bonnassieux, H. Abou-Kindil, J.P. Louis, "Controller design and robustness analysis for induction machine-based poisoning system," *Control engineering practice*, vol. 12. pp.757-767.,2004.
- [8] J. Hu, D. M. Dawson, Y, Qian, "Position tracking control of induction motor via partial state feedback," *Automatica.*,vol. 31, No. 7, pp.989-1995, 1995.
- [9] M. W. Dunnigan, S. Wade, B.W, Williams, "Position control of a vector controlled induction machine using slotine'sliding mode control approach," *IEE Proc-Electro.Power Appl.* vol. 145.no.3. pp.131-138.,1998.
- [10] P. Vas. *Vector control of AC machines.* Edition Oxford University Press, 1990.
- [11] C. Canudas de Wit. *Commande des moteurs asynchrone : 1- Modélisation, control vectoriel et DTC.* Edition Hermès Science Publications, Paris 2000.
- [12] C. Canudas de Wit. *Commande des moteurs asynchrones : 2- Optimisation, discrétisation et observation.* Edition Hermès Science Publications, Paris 2000.
- [13] A. Hazzab, I, K, Bousserhane, K, Kamli, "Design of a sliding mode controller by genetic algorithms for induction machine speed control," *International journal of emrging electric Power systems*, vol.1. issue 2. pp.1-17.,2004
- [14] L.K Wong, F. H. F. Leung, P. K. S. Tam, "A fuzzy sliding controller for non linear systems", *IEEE Trans. Ind. electronic.*, vol. 48,no.1, pp.32-37, Feb.2001.
- [15] R. G Spiegle, M.N Turner, V. E. McCormick, "A fuzzy-logic controllers for efficiency optimization of inverter-fed induction motor drives", *Fuzzy Sets and Systems*, vol. 137 pp.387-401, 2003.
- [16] R. palm, "Robust control by fuzzy sliding mode *Automatica.*, vol. 31, No. 9, pp.1429-1437, 1994.
- [17] L.K Wong, F. H. F. Leung, P. K. S. Tam, "a fuzzy sliding controller for non linear systems", *IEEE Trans. Ind. electronic.*, vol. 48,no.1, pp.32-37, Feb.2001.

Mohamed ABID received the B.S., M.S., and Ph.D degrees in electrical engineering from University of Sidi Bel-Abbès, Algeria, in 1990, 1997, and 2005, respectively. He is currently professor of electrical engineering and researcher in IRECOM laboratory at University of Sidi Bel-Abbès, Algeria. His mains areas of research interests are modeling and simulation of electric machines, sliding mode in continuous systems, control of electric drives.

Abdel Ghani AISSAOUI received the B.S., M.S., and Ph.D degrees in electrical engineering from University of Sidi Bel-Abbès, Algeria, in 1993, 1997, and 2007, respectively. He is currently professor of electrical engineering at University of Bechar, Algeria. His current research interest includes power electronics and control of electrical machines.

Ayad Abdelghani received the B.Sc. and M.Sc. degrees in electrical engineering from the University of Djillali Liabès, Sidi Bel-Abbes, in 1995 and 2003, respectively. He received his Ph.D. degree in electrical engineering from the University of Djillali Liabès, Sidi Bel-Abbès in 2009. He is now professor in the Department of Electrical Engineering at the University of Djillali Liabès. His mains areas of research interests are control of electric drives, control non destructive, compatibility and active filter of harmonic.

Ahmed Tahour received the B.S., M.S., and Ph.D degrees in electrical engineering from University of Sidi Bel-Abbès, Algeria, in 1996, 1999, and 2007, respectively. He is currently professor of electrical engineering at University of Mascara, Algeria. His current research interest includes: application of the artificial intelligence techniques (fuzzy set, neural networks, neuro-fuzzy) in control of electrical machines.